

**H3** SITE PHOTOMETRIC PLAN  
SCALE: 1" = 30'-0"

LUMINAIRE SCHEDULE - BUILDING MOUNT				
SYMBOL	LABEL	CATALOGUE NUMBER	LAMP	WATTS
●	N	LDN6 4015 L06AR LS MVOLT GZ10 LITHONIA	LED	19
□	P	SLIM17F15ADJ RAB LIGHTING	LED	15
□	S	CD34-6WZ RAB	LED	22

LUMINAIRE SCHEDULE - SITE LIGHTING				
SYMBOL	LABEL	CATALOGUE NUMBER	LAMP	WATTS
□	A-BLC3	DSX1 LED P5 35K 80CRI/BLC3 20' POLE; POLE BASE @ 6" ABOVE GRADE	LED	138.16
□	A-BLC3-2	DSX1 LED P5 35K 80CRI/BLC3 20' POLE; POLE BASE @ 6" ABOVE GRADE	LED	276.32

PRELIMINARY

	<b>NEW CULVER'S RESTAURANT</b> <b>5074 Gateway Drive</b> Plainfield, IN 46168 County of HENDRICKS
	Culver Franchising System, Inc. 1240 Water Street Prairie du Sac, WI 53578 608-643-7960
<b>CONSULTANT:</b> RTM ENGINEERING CONSULTANTS 650 E Algonquin Rd, Suite 250 Schaumburg, Illinois 60173 847-756-4180 Phone	<b>OWNER:</b> S&L PROPERTIES PLAINFIELD SOUTH LLC 2651 Kicking Court Portage, WI 53901 Jeff Liegal 608-742-2893
<b>OLLIMANN ASSOCIATES ARCHITECTS, P.C.</b> 200 South State Street Belvidere, Illinois 61008 815-544-7790 Phone <small>© OAA. All rights reserved. Any copying, transmission or disclosure subject to OAA written approval.</small>	
<b>SITE PHOTOMETRIC PLAN</b>	Revision:
Date: 12-9-2025	2025-088

CD34-6WZ

RAB



Color: Bronze Weight: 6.3 lbs

Project, Type, Prepared By, Date form.

Driver Info and LED Info table.

Technical Specifications

Technical Specifications table with Performance, Description, Wattage, Input, Nominal, Efficacy, Lifespan, Electrical, THD, Flicker, Photocell, Dimmable, LED Characteristics, Light Distribution, Color Temperature, Color Accuracy, R9 Value, Color Consistency, and Operating Temperature.

Need help? Tech help line: (888) 722-1000 Email: techsupport@rablighting.com Website: www.rablighting.com

Page 1 of 3

LITHONIA LIGHTING

FEATURES & SPECIFICATIONS

INTENDED USE, CONSTRUCTION, A+ CAPABLE LUMINAIRE, UGR, ELECTRICAL, LUMEN MAINTENANCE, LISTINGS, BUY AMERICAN ACT, WARRANTY.

PERFORMANCE DATA

Performance Data table with columns: Nominal Lumens, Lumens, Wattage, Lm/W.

Notes: Tested in accordance with IESNA LM-79-08, Tested to current IES and NEMA standards under stabilized laboratory conditions, CRI: 80 typical.



DOWNLIGHTING

Catalog Number, Notes, Type form.

LDN6 STATIC WHITE

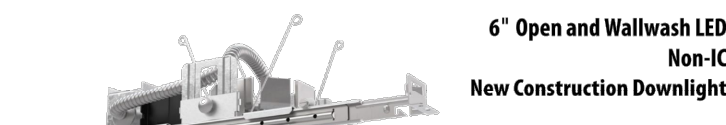

DISTRIBUTIONS

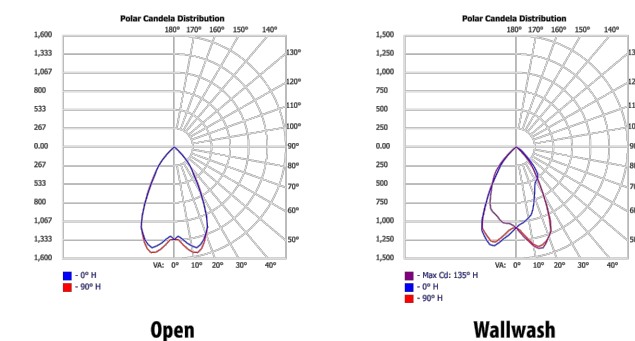

DIMENSIONS

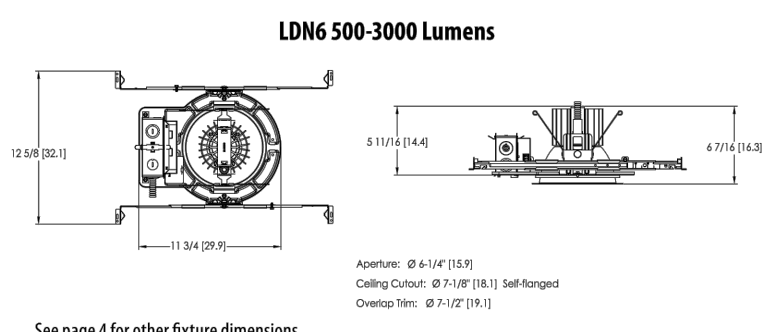

See page 4 for other fixture dimensions

LDN6

SLIM17FA15ADJ

RAB



Color: Bronze Weight: 3.0 lbs

Project, Type, Prepared By, Date form.

Driver Info and LED Info table.

Technical Specifications

Technical Specifications table with Field Adjustability, Performance, Photocell, Field Adjustability, Lifespan, Construction, Wattage, Cold Weather Starting, LED Characteristics, Electrical, and Dimming Driver.

Need help? Tech help line: (888) 722-1000 Email: sales@rablighting.com Website: www.rablighting.com

Page 1 of 2

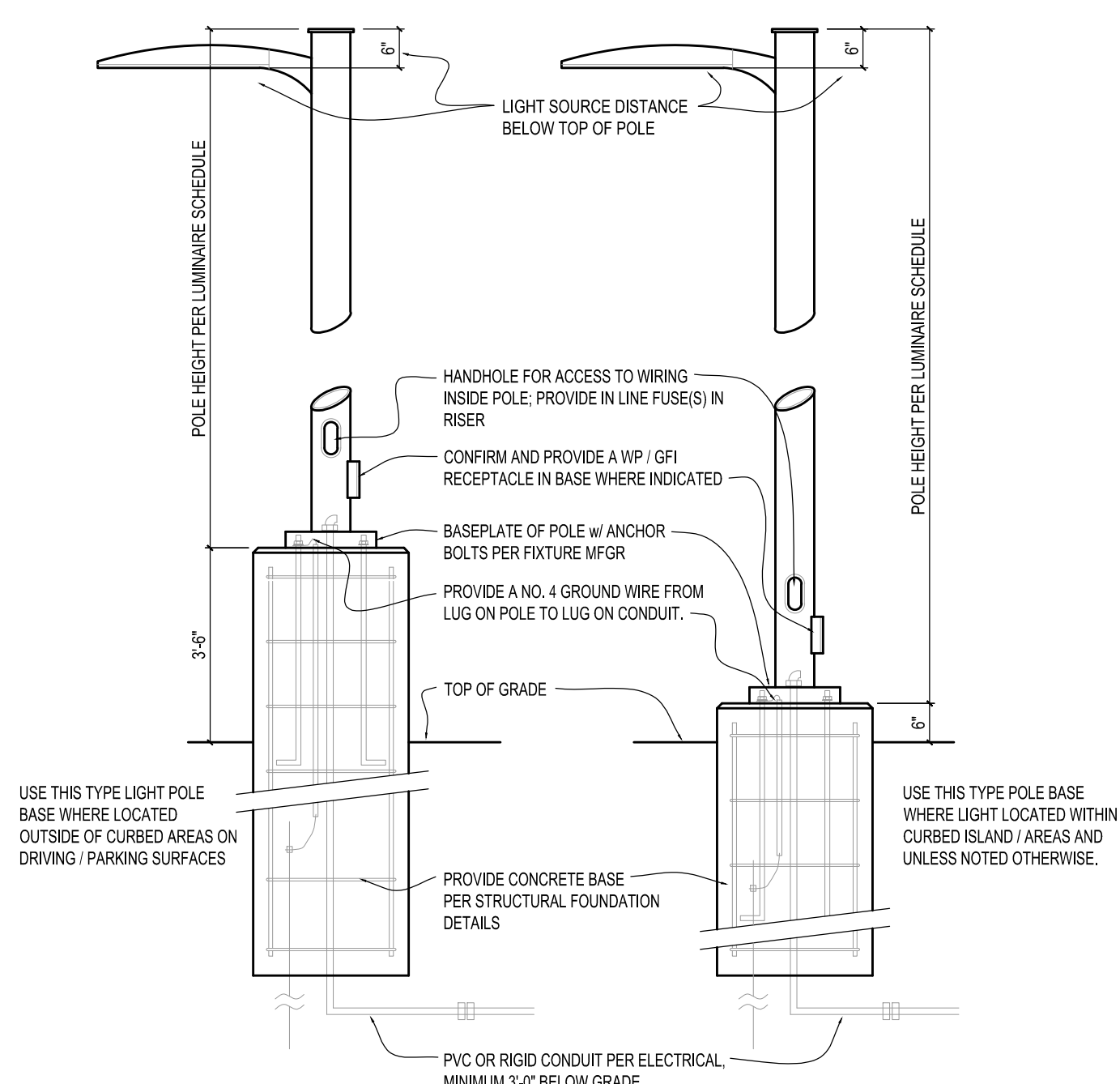

LIGHT POLE DETAIL

NO SCALE

D-Series Size 1 LED Area Luminaire



Specifications table with columns: Length, Width, Height H1, Height H2, Weight.

Introduction: The modern styling of the D-Series features a highly refined aesthetic that blends seamlessly with its environment.

Ordering Information EXAMPLE: DSX1 LED P7 40K 70CRI T3M MVOLTS SPA NLTAIR2 PIRHN DDBXD

Ordering Information table with columns: Series, LED, Color Temperature, Color Rendering Index, Distribution, Voltage, Mounting.

Control options, Shipped installed, and Shipped separately table.

Vertical sidebar containing project details: NEW CULVER'S RESTAURANT, 5074 Gateway Drive, Plainfield, IN 46168, County of HENDRICKS, CONSULTANT: RTM ENGINEERING CONSULTANTS, OWNER: S&L PROPERTIES, OLLMANN ASSOCIATES ARCHITECTS, P.C., SITE FIXTURE DETAILS, Revision: 12-9-2025, Date: 12-9-2025, SE 201.