

BENCHMARK INFORMATION

ORIGINATING BENCHMARK
 L-61 (PID: KA0040)
 1.2 MILES SOUTHEAST FROM PLAINFIELD
 ABOUT 1.2 MILES ALONG STATE HIGHWAY 267 FROM ITS JUNCTION WITH U.S. HIGHWAY 40 AT PLAINFIELD, AT A CROSS ROAD, 45 FEET WEST OF AND ABOUT LEVEL WITH THE CENTER LINE OF THE HIGHWAY, 26 FEET NORTH OF THE CENTER LINE OF THE ENTRANCE TO THE EDWARD CUMMINGS FARM, 14 FEET NORTHWEST OF THE NORTH END OF A 12-INCH CORRUGATED PIPE CULVERT, 7 FEET WEST OF TELEPHONE POLE NO. 36-H 62, 4 FEET WEST OF A CONCRETE FENCE CORNER POST, AND 2 FEET EAST OF A WHITE WOODEN WITNESS POST. A STANDARD DISK, STAMPED L 61 1946 AND SET IN THE TOP OF A CONCRETE POST PROJECTING 8 INCHES ABOVE GROUND.
 ELEV: 715.41 (NAVD 88)

LAND DESCRIPTION

LOT NUMBERED TWO (2) IN CAMBRIDGE SQUARE WEST, PHASE 1, A SUBDIVISION IN THE TOWN OF PLAINFIELD, HENDRICKS COUNTY, INDIANA, AS PER PLAT THEREOF AS RECORDED MARCH 4, 1988 IN PLAT BOOK 13, PAGES 34-35 AND SURVEYOR'S CERTIFICATE OF ERROR RECORDED MARCH 23, 1988 AS BOOK 114, PAGE 66 IN THE OFFICE OF THE RECORDER OF HENDRICKS COUNTY, INDIANA.

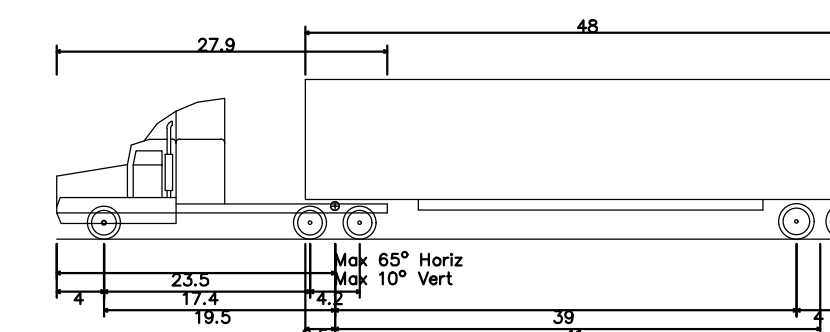

WB-62 - Interstate Semi-Trailer
 Overall Length 69.00ft
 Overall Width 8.50ft
 Overall Body Height 13.50ft
 Min Body Ground Clearance 1.33ft
 Max Track Width 8.50ft
 Lock-to-lock time 6.00s
 Max Steering Angle (Virtual) 28.40



Chick-fil-A

Chick-fil-A
 5200 Buffington Road
 Atlanta, Georgia 30349-2998

PEA GROUP

t: 844.813.2949
 www.peagroup.com



STATE ROAD 267 (QUAKER BLVD)
 (PUBLIC RIGHT-OF-WAY)

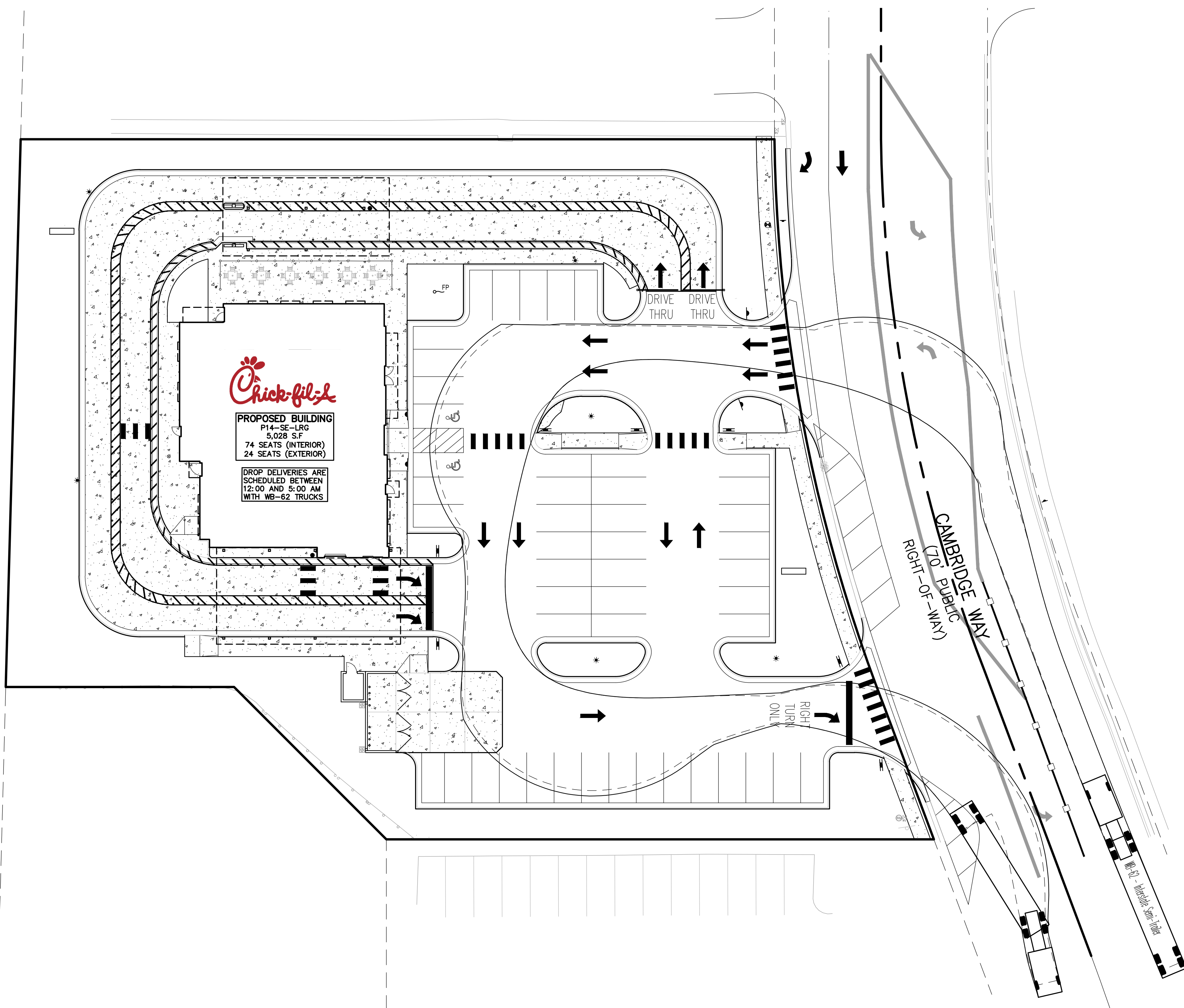

PROPOSED BUILDING
 P14-SE-LRG
 5,029 SF
 74 SEATS (INTERIOR)
 24 SEATS (EXTERIOR)
 DROP DELIVERIES ARE
 SCHEDULED BETWEEN
 12:00 AND 5:00 AM
 WITH WB-62 TRUCKS

CHICK-FIL-A
 PLAINFIELD
 6102 CAMBRIDGE WAY
 PLAINFIELD, IN 46168

FSR#05219

BUILDING TYPE / SIZE: P14-SE-LRG
 RELEASE: AUGUST 2022

NO.	DATE	DESCRIPTION
1	7/26/2023	TRAFFIC UPDATES

CONSULTANT PROJECT #	2022-1054
PRINTED FOR	SPA
DATE	APRIL 14, 2023
DRAWN BY	LGD

Information contained on this drawing and in all digital files produced for above named project may not be reproduced in any manner without express written or verbal consent from authorized project representatives.

SHEET
 WB-62 TRUCK
 TURNING PLAN

SHEET NUMBER

C-201