

FLOOR DRAINS

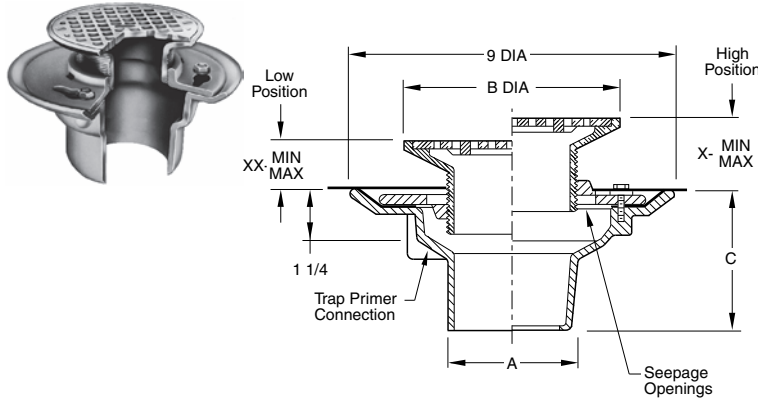

FIG. 2005 (-A) FLOOR DRAIN WITH ADJ. ROUND STRAINER
FIG. 2010 (-A) FLOOR DRAIN WITH ADJ. ROUND STRAINER

FUNCTION: General service floor drain for use in showers, toilets, kitchens and other finished areas where foot traffic is expected. The round top strainer head is used for all types of poured finished floors. Reversible flashing collar permits adjustment of the strainer to meet finished floor level.



OUTLET VARIATIONS (Specify type of outlet and pipe size in inches.)

Outlet Type	Outlet Designation	Outlet Type/Pipe Size	"C" Body HT. DIM.	ADD
Inside Caulk (2010)C02, C03, C04	4"	N/C
Speedi-Set SW (2005)L02, L03, L04	4"	N/C
Speedi-Set XH (2005)LXH02, LXH03, LXH04	4"	N/C
Threaded(2010)T02, T03, T04	3"	61.00
No-Hub (2005)Y02, Y03, Y04	4"	N/C

OPTIONS:

Option	Description	ADD
-ARI	Acid Resistant Inside or Outside	132.00
-ARIO	Acid Resistant Inside & Outside	132.00
-B	Sediment Bucket	85.00
-BB	Bronze Body, 02-04" 05-06"	952.00
-BFV	Ball Float Bkwtr Valve	298.00
-DID	Drain Installation Device	See Fig. 2038
-G	Galvanized Body	154.00
-H	Hinged Grate	219.00
-P	Trap Primer Conn	N/C
-U	Vandal Proof Screws	43.00
-V	Flapper Backwater Valve	298.00

A OUTLET SIZE	B TOP SIZE	*X MIN MAX	*XX MIN MAX	PB TOP	†NB TOP	CP TOP	APPROX. WEIGHT LBS.
02, 03, 04"	05"	1 1/4 2 1/4	3/4 1 5/8	361.00	380.00	401.00	12
02, 03, 04"	06"	1 1/4 2 1/4	3/4 1 5/8	419.00	465.00	495.00	13
02, 03, 04"	07"	1 1/4 2 1/4	7/8 1 7/8	509.00	536.00	574.00	14
02, 03, 04"	08"	1 1/2 2 1/2	1 1 7/8	636.00	673.00	727.00	15
02, 03, 04"	•09"	1 1/2 2 3/8	1 1 7/8	870.00	918.00	994.00	18
02, 03, 04"	•10"	1 1/2 2 3/8	1 1 7/8	870.00	918.00	994.00	21

REGULARLY FURNISHED: Duco Cast Iron Body with Flashing Collar and Adjustable Round Strainer Head.

*Add 3/8" to min/max dimensions for round strainers.
 *Collar is reversible to obtain extreme high and low strainer positions.

FIG. 2005 (-B) FLOOR DRAIN WITH ADJ. SQUARE STRAINER
FIG. 2010 (-B) FLOOR DRAIN WITH ADJ. SQUARE STRAINER

FUNCTION: General service floor drain for use in showers, toilets, kitchens and other finished areas where foot traffic is expected. The square top is particularly adaptable to floors that are finished in material of square or straight line pattern. Reversible flashing collar permits adjustment of the strainer to meet finished floor level.

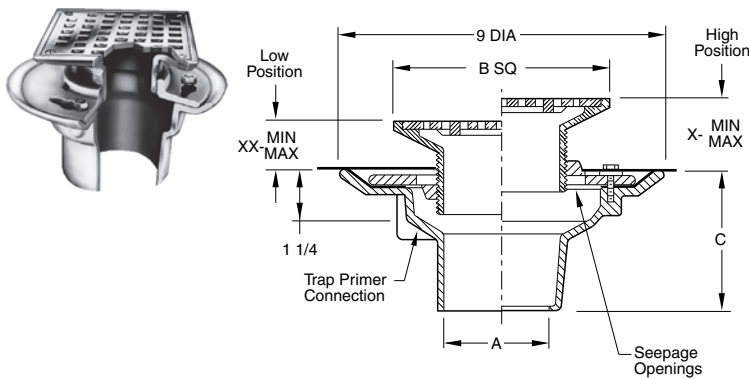

OUTLET VARIATIONS (Specify type of outlet and pipe size in inches.)

Outlet Type	Outlet Designation	Outlet Type/Pipe Size	"C" Body HT. DIM.	ADD
Inside Caulk (2010)C02, C03, C04	4"	N/C
Speedi-Set SW (2005)L02, L03, L04	4"	N/C
Speedi-Set XH (2005)LXH02, LXH03, LXH04	4"	N/C
Threaded (2010)T02, T03, T04	3"	61.00
No-Hub (2005)Y02, Y03, Y04	4"	N/C

OPTIONS:

Option	Description	ADD
-ARI	Acid Resistant Inside or Outside	132.00
-ARIO	Acid Resistant Inside & Outside	132.00
-B	Sediment Bucket	85.00
-BB	Bronze Body, 02-04" 05-06"	952.00
-BFV	Ball Float Backwater Valve	298.00
-DID	Drain Installation Device	See Fig. 2038
-G	Galvanized Body	154.00
-H	Hinged Grate	219.00
-P	Trap Primer Conn	N/C
-U	Vandal Proof Screws	43.00
-V	Flapper Backwater Valve	298.00

A OUTLET SIZE	B TOP SIZE	*X MIN MAX	*XX MIN MAX	PB TOP	†NB TOP	CP TOP	APPROX. WEIGHT LBS.
02, 03, 04"	05 x 05"	1 1/4 2 1/4	3/4 1 5/8	465.00	508.00	541.00	12
02, 03, 04"	06 x 06"	1 1/4 2 1/4	3/4 1 5/8	536.00	566.00	609.00	13
02, 03, 04"	07 x 07"	1 1/4 2 1/4	7/8 1 7/8	635.00	680.00	732.00	14
02, 03, 04"	08 x 08"	1 1/2 2 1/2	1 1 7/8	743.00	822.00	883.00	15
02, 03, 04"	09 x 09"	1 1/2 2 3/8	1 1 7/8	951.00	1,041.00	1,126.00	18
02, 03, 04"	10 x 10"	1 1/2 2 3/8	1 1 7/8	1,220.00	1,308.00	1,425.00	21

REGULARLY FURNISHED: Duco Cast Iron Body with Flashing Collar and Adjustable Square Strainer Head.

*Collar is reversible to obtain extreme high and low strainer positions.
 When ordering, specify drain body and strainer type, size and finish. Ex. 2005Y04 w/A05NB.

†REGULARLY FURNISHED

FLOOR DRAINS

FLOOR DRAINS

SMITH®



CUSTOMER DRIVEN SINCE 1926

FIG. 2005 (-BS) FLOOR DRAIN AND ADJ. STRAINER WITH SQUARE SOLID HINGED COVER FIG. 2010 (-BS) FLOOR DRAIN AND ADJ. STRAINER WITH SQUARE SOLID HINGED COVER

FUNCTION: General service floor drain for use in showers, toilets, kitchens and other finished areas where foot traffic is expected. Reversible flashing collar permits adjustment of the strainer to meet finished floor level.

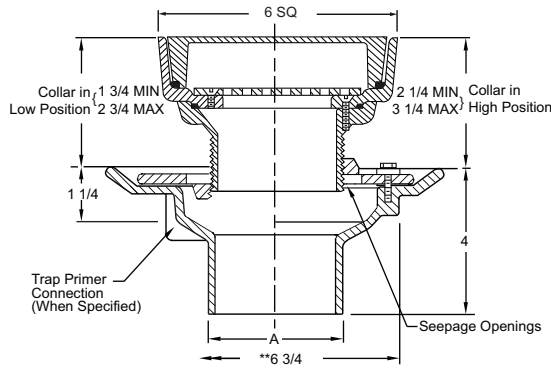

OUTLET VARIATIONS (Specify type of outlet and pipe size in inches.)

Outlet Type	Outlet Designation	Outlet Type/Pipe Size	"C" Body HT. DIM.	ADD
Inside Caulk (2010)	C02, C03, C04		4"	N/C
Speedi-Set SW (2005)	L02, L03, L04		4"	N/C
Speedi-Set XH (2005)	LXH02, LXH03, LXH04		4"	N/C
Threaded (2010)	T02, T03, T04		3"	61.00
No-Hub (2005)	Y02, Y03, Y04		4"	N/C

OPTIONS:

Options	ADD
-ARI Acid Resistant Inside or Outside	132.00
-ARIO Acid Resistant Inside & Outside	132.00
-B Sediment Bucket	POA
-BB Bronze Body, 02-04"	952.00
05-06"	2,927.00
-DID Drain Installation Device	See Fig. 2038
-G Galvanized Body	154.00
-GC Gasketed/Water Tight	64.00
-P Trap Primer Conn	N/C
-SEC Secured Cover	43.00
-SS Secondary Strainer	49.00
-U Vandal Proof Screws	43.00

A OUTLET SIZE	B TOP SIZE	X MIN	X MAX	XX MIN	XX MAX	PB TOP	†NB TOP	CP TOP	APPROX. WEIGHT LBS.
02, 03, 04"	06 x 06"	1 1/4	2 1/4	3/4	1 5/8	859.00	978.00	1,062.00	11

REGULARLY FURNISHED: Duco Cast Iron Body with Flashing Collar and Adjustable Strainer with Hinged Solid Cover.

FIG. 2005 (-C) FLOOR DRAIN AND ADJ. STRAINER WITH ROUND REINFORCED GRATE FIG. 2010 (-C) FLOOR DRAIN AND ADJ. STRAINER WITH ROUND REINFORCED GRATE

FUNCTION: General service floor drain for use in showers, toilets, kitchens and other finished areas where foot traffic is expected. Reversible flashing collar permits adjustment of the strainer to meet finished floor level. Used in finished floors where light wheeled loads are anticipated.

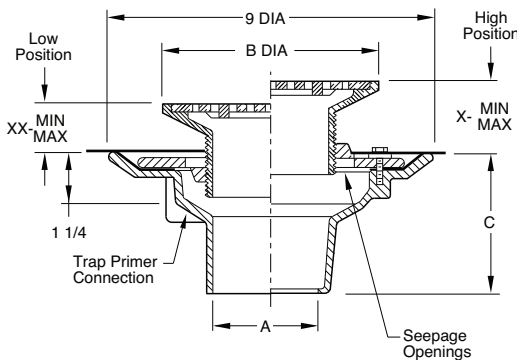

OUTLET VARIATIONS (Specify type of outlet and pipe size in inches.)

Outlet Type	Outlet Designation	Outlet Type/Pipe Size	"C" Body HT. DIM.	ADD
Inside Caulk (2010)	C02, C03, C04		4"	N/C
Speedi-Set SW (2005)	L02, L03, L04		4"	N/C
Speedi-Set XH (2005)	LXH02, LXH03, LXH04		4"	N/C
Threaded (2010)	T02, T03, T04		3"	61.00
No-Hub (2005)	Y02, Y03, Y04		4"	N/C

OPTIONS:

Options	ADD
-ARI Acid Resistant Inside or Outside	132.00
-ARIO Acid Resistant Inside & Outside	132.00
-B Sediment Bucket	85.00
-BB Bronze Body, 02-04"	952.00
05-06"	2,927.00
-BFV Ball Float Bkwtr Valve	298.00
-DID Drain Installation Device	See Fig. 2038
-G Galvanized Body	154.00
-P Trap Primer Conn	N/C
-U Vandal Proof Screws	43.00
-V Flapper Backwater Valve	298.00

A OUTLET SIZE	B TOP SIZE	X MIN	X MAX	XX MIN	XX MAX	PB TOP	†NB TOP	CP TOP	APPROX. WEIGHT LBS.
02, 03, 04"	05"	1 1/4	2 1/4	3/4	1 5/8	527.00	545.00	566.00	13
02, 03, 04"	06"	1 1/4	2 1/4	3/4	1 5/8	583.00	628.00	658.00	15
02, 03, 04"	08"	1 1/2	2 1/2	1	1 7/8	801.00	834.00	881.00	17
02, 03, 04"	10"	1 1/2	2 3/8	1	1 7/8	1,033.00	1,080.00	1,158.00	19

REGULARLY FURNISHED: Duco Cast Iron Body with Flashing Collar and Adjustable Strainer with Round Reinforced Grate.

When ordering, specify drain body and strainer type, size and finish. Ex. 2005Y04 w/A05NB.

FLOOR DRAINS



FIG. DX2005 (A) FLOOR OR SHOWER DRAIN AND ADJ. WIDE FLANGE STRAINER WITH ROUND GRATE
FIG. DX2010 (B) FLOOR OR SHOWER DRAIN AND ADJ. WIDE FLANGE STRAINER WITH SQUARE GRATE

FUNCTION: Used in any floor or shower area. Four inch wide flange allows ample surface adhesion of traffic bearing deck covering.

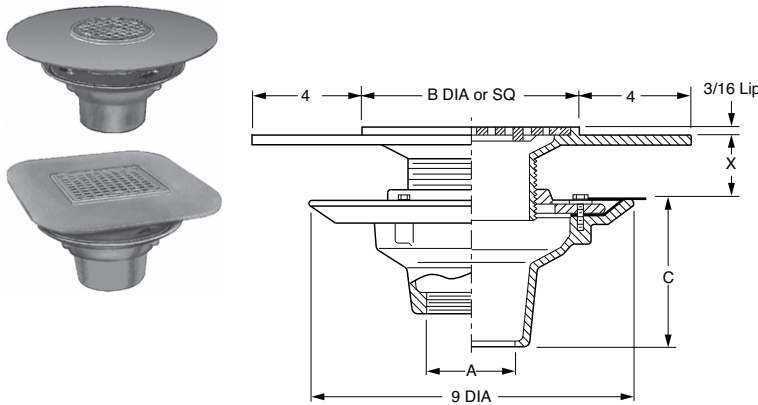

OUTLET VARIATIONS (Specify type of outlet and pipe size in inches.)

Outlet Type	Outlet Designation	Outlet Type/Pipe Size	"C" Body HT. DIM.	ADD
Inside Caulk (2010)	C02, C03, C04		4"	N/C
Speedi-Set SW (2005)	L02, L03, L04		4"	N/C
Speedi-Set XH (2005)	LXH02, LXH03, LXH04		4"	N/C
Threaded (2010)	T02, T03, T04		3"	61.00
No-Hub (2005)	Y02, Y03, Y04		4"	N/C

OPTIONS:

Option	Description	ADD
-ARI	Acid Resistant Inside or Outside	132.00
-ARIO	Acid Resistant Inside & Outside	132.00
-BB	Bronze Body, 02-04"	952.00
	05-06"	2,927.00
-DID	Drain Installation Device	See Fig. 2038
-G	Galvanized Body	154.00
-LWH	Less Weep Holes	N/C
-P	Trap Primer Conn	N/C
-SH	Sec Holes in Flange	96.00
-U	Vandal Proof Screws	43.00

A OUTLET SIZE	B STRAINER SIZE	X MIN	X MAX	PB TOP	†NB TOP	CP TOP	APPROX. WEIGHT LBS.
02, 03, 04"	05"	1 1/4	2	1,056.00	1,098.00	1,194.00	27
02, 03, 04"	06"	1 1/4	2	1,056.00	1,098.00	1,194.00	29

REGULARLY FURNISHED: Duco Cast Iron Body, Adjustable Strainer as Indicated by Suffix Letter Selected with 4" Wide Flange and Secondary Flashing Flange.

FIG. 2005(-D) FLOOR DRAIN AND ADJ. STRAINER WITH ROUND REINFORCED TRACTOR GRATE
FIG. 2010(-E) FLOOR DRAIN AND ADJ. STRAINER WITH ROUND REINFORCED TRACTOR GRATE

FUNCTION: Used in finished floors where medium weight wheeled loads are anticipated and loose set non-tilt tractor grate is desired.

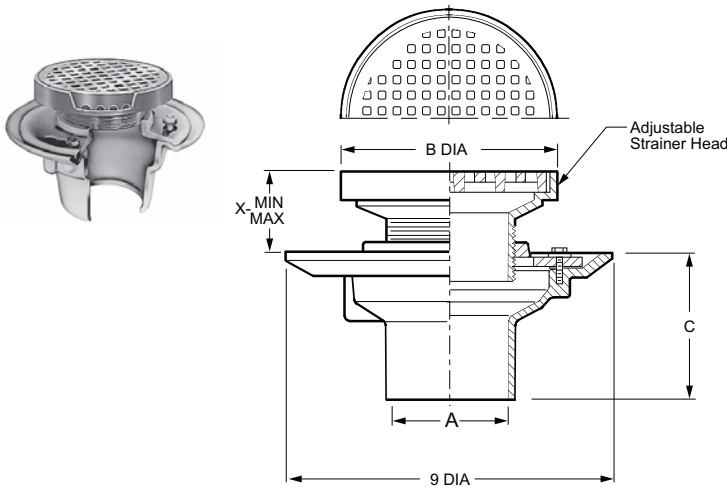

OUTLET VARIATIONS (Specify type of outlet and pipe size in inches.)

Outlet Type	Outlet Designation	Outlet Type/Pipe Size	"C" Body HT. DIM.	ADD
Inside Caulk (2010)	C02, C03, C04		4"	N/C
Speedi-Set SW (2005)	L02, L03, L04		4"	N/C
Speedi-Set XH (2005)	LXH02, LXH03, LXH04		4"	N/C
Threaded (2010)	T02, T03, T04		3"	61.00
No-Hub (2005)	Y02, Y03, Y04		4"	N/C

OPTIONS:

Option	Description	ADD
-ARI	Acid Resistant Inside or Outside	132.00
-ARIO	Acid Resistant Inside & Outside	132.00
-B	Sediment Bucket	85.00
-BB	Bronze Body, 02-04"	952.00
	05-06"	2,927.00
-BFV	Ball Float Backwater Valve	298.00
-DID	Drain Installation Device	See Fig. 2038
-G	Galvanized CI Body	154.00
-P	Trap Primer Conn	N/C
-U	Vandal Proof Screws	43.00
-V	Backwater Valve	298.00

A OUTLET SIZE	STRAINER SUFFIX	B TOP SIZE	X MIN	X MAX	CI TOP	PB TOP	†NB TOP	CP TOP	APPROX. WEIGHT LBS.
02, 03, 04"	D	07"	2 1/4	3 1/4	425.00	806.00	879.00	951.00	14
02, 03, 04"	E	09"	2 3/4	3 1/2	523.00	1,131.00	1,222.00	1,330.00	6

REGULARLY FURNISHED: Duco Cast Iron Body and Flashing Collar, Adjustable Strainer Head as Indicated by Suffix Letter Selected. Medium Duty Tractor Grate.

When ordering, specify drain body and strainer type, size and finish. Ex. 2005Y04 w/A05NB.

FLOOR DRAINS

SMITH®



FIG. 2005 (-F) FLOOR DRAIN AND ADJ. TILE FLANGE STRAINER WITH ROUND GRATE FIG. 2010 (-F) FLOOR DRAIN AND ADJ. TILE FLANGE STRAINER WITH ROUND GRATE

FUNCTION: Provides integral flange set 5/32" below rim to receive floor covering. Flange may have option of tapped holes for securing pan and gasket.

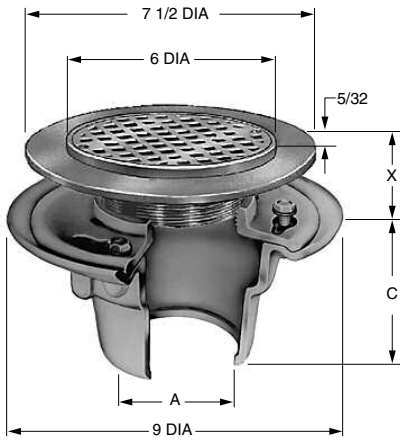

A OUTLET SIZE	STRAINER SIZE	X MIN MAX	DUCO CI PB TOP	DUCO CI †NB TOP	DUCO CI CP TOP	APPROX. WEIGHT LBS.
02, 03, 04"	06"	1 1/4 2 1/8	806.00	881.00	951.00	14

REGULARLY FURNISHED: Duco Cast Iron Body and Flashing Collar, Adjustable Strainer Head as Indicated by Suffix Letter Selected.

OUTLET VARIATIONS (Specify type of outlet and pipe size in inches.)

Outlet Type	Outlet Designation	Outlet Type/Pipe Size	"C" Body HT. DIM.	ADD
Inside Caulk (2010)	C02, C03, C04		4"	N/C
Speedi-Set SW (2005)	L02, L03, L04		4"	N/C
Speedi-Set XH (2005)	LXH02, LXH03, LXH04		4"	N/C
Threaded (2010)	T02, T03, T04		3"	61.00
No-Hub (2005)	Y02, Y03, Y04		4"	N/C

OPTIONS:

OPTION	DESCRIPTION	ADD
-ARI	Acid Resistant Inside or Outside	132.00
-ARIO	Acid Resistant Inside & Outside	132.00
-B	Sediment Bucket	85.00
-BB	Bronze Body, 02-04"	952.00
	05-06"	2,927.00
-BFV	Ball Float Backwater Valve	298.00
-DID	Drain Installation Device	See Fig. 2038
-G	Galvanized Body	154.00
-P	Trap Primer Conn	N/C
-SH	Tapped Holes in Flange	96.00
-U	Vandal Proof Screws	43.00
-V	Flapper Backwater Valve	298.00

FIG. 2005 (-F37) FLOOR DRAIN AND ADJ. STRAINER WITH ROUND RECESSED GRATE FIG. 2010 (-F38) FLOOR DRAIN AND ADJ. STRAINER WITH ROUND RECESSED GRATE

FUNCTION: Used in a non-traffic area when a funnel type strainer head is required and space does not allow use of the 3500 Series funnel. The extended rim allows use as an anti-flood and anti-splash drip pan.

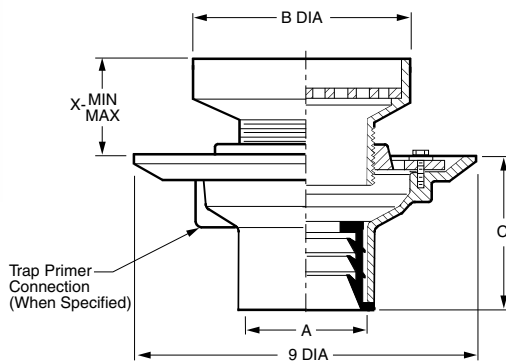

A OUTLET SIZE	STRAINER SUFFIX	B TOP SIZE	X MIN MAX	CI TOP	PB TOP	†NB TOP	CP TOP	APPROX. WEIGHT LBS.
02, 03, 04"	F37	07"	2 5/8 3 1/2	423.00	806.00	881.00	952.00	19
02, 03, 04"	F38	09"	2 3/4 3 1/2	523.00	1,134.00	1,237.00	1,342.00	22

REGULARLY FURNISHED: Duco Cast Iron Body and Flashing Collar, Adjustable Nickel Bronze Strainer Head as Indicated by Suffix Letter Selected. Flush with Floor Funnel with Anti-Splash Rim and Grate.

OUTLET VARIATIONS (Specify type of outlet and pipe size in inches.)

Outlet Type	Outlet Designation	Outlet Type/Pipe Size	"C" Body HT. DIM.	ADD
Inside Caulk (2010)	C02, C03, C04		4"	N/C
Speedi-Set SW (2005)	L02, L03, L04		4"	N/C
Speedi-Set XH (2005)	LXH02, LXH03, LXH04		4"	N/C
Threaded (2010)	T02, T03, T04		3"	61.00
No-Hub (2005)	Y02, Y03, Y04		4"	N/C

OPTIONS:

OPTION	DESCRIPTION	ADD
-ARI	Acid Resistant Inside or Outside	132.00
-ARIO	Acid Resistant Inside & Outside	132.00
-BB	Bronze Body, 02-04"	952.00
	05-06"	2,927.00
-DID	Drain Installation Device	See Fig. 2038
-G	Galvanized CI Body	154.00
-GS	Galvanized Body & Strainer	
	F37 (add to CI)	272.00
	F38 (add to CI)	372.00
-P	Trap Primer Conn	N/C

When ordering, specify drain body and strainer type, size and finish. Ex. 2005Y04 w/A05NB.

†REGULARLY FURNISHED

FLOOR DRAINS

SMITH®

FIG. 2005 (-G) FLOOR DRAIN AND ADJ. STRAINER WITH ROUND LOW DOME GRATE
FIG. 2010 (-G) FLOOR DRAIN AND ADJ. STRAINER WITH ROUND LOW DOME GRATE



CUSTOMER DRIVEN SINCE 1926

FUNCTION: Used in gutters and recessed areas where excessive debris build-up is expected. Dome insures drainage even when partly covered.

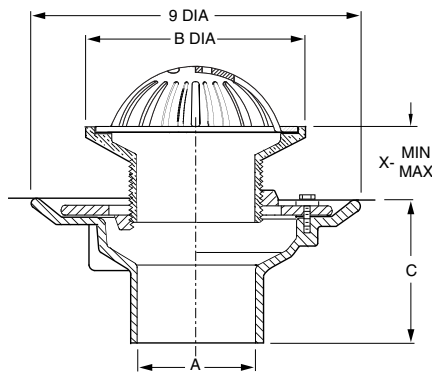

OUTLET VARIATIONS (Specify type of outlet and pipe size in inches.)

Outlet Type	Outlet Designation	Outlet Type/Pipe Size	"C" Body HT. DIM.	ADD
Inside Caulk (2010)	C02, C03, C04		4"	N/C
Speedi-Set SW (2005)	L02, L03, L04		4"	N/C
Speedi-Set XH (2005)	LXH02, LXH03, LXH04		4"	N/C
Threaded(2010)	T02, T03, T04		3"	61.00
No-Hub (2005)	Y02, Y03, Y04		4"	N/C

OPTIONS:	ADD
-B Sediment Bucket	85.00
-BB Bronze Body, 02-04"	952.00
05-06"	2,927.00
-BFV Ball Float Backwater Valve	298.00
-DID Drain Installation Device	See Fig. 2038
-G Galvanized Body	154.00
-MS SS Mesh on Dome	185.00
-P Trap Primer Conn	N/C
-U Vandal Proof Screws	43.00
-V Flapper Type Backwater Valve	298.00

A OUTLET SIZE	B STRAINER SIZE	X MIN MAX	DUCO CI PB TOP	DUCO CI †NB TOP	DUCO CI CP TOP	APPROX. WEIGHT LBS.
02, 03, 04"	05"	1 1/4 2 1/4	508.00	536.00	575.00	11
02, 03, 04"	06"	1 1/4 2 1/4	578.00	641.00	690.00	13
02, 03, 04"	08"	1 1/2 2 1/2	761.00	805.00	870.00	16

REGULARLY FURNISHED: Duco Cast Iron Body with Flashing Collar and Adjustable Low Dome Strainer Head.

FLOOR DRAINS

FIG. 2005 (-H) FLOOR DRAIN AND ADJ. STRAINER WITH ROUND SOLID HINGED COVER
FIG. 2010 (-H) FLOOR DRAIN AND ADJ. STRAINER WITH ROUND SOLID HINGED COVER

FUNCTION: Used in areas where intermittent drain use is required. Solid cover prevents intrusion of chips, sawdust, etc., which are swept up before cover is opened for washdown. The secondary strainer prevents debris from entering the waste line.

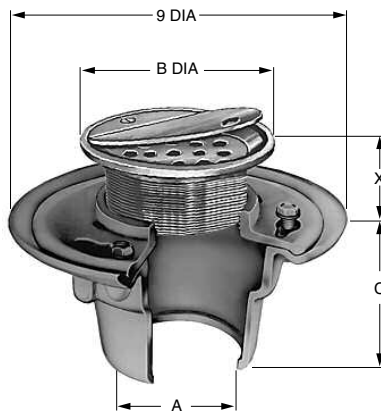

OUTLET VARIATIONS (Specify type of outlet and pipe size in inches.)

Outlet Type	Outlet Designation	Outlet Type/Pipe Size	"C" Body HT. DIM.	ADD
Inside Caulk (2010)	C02, C03, C04		4"	N/C
Speedi-Set SW (2005)	L02, L03, L04		4"	N/C
Speedi-Set XH (2005)	LXH02, LXH03, LXH04		4"	N/C
Threaded(2010)	T02, T03, T04		3"	61.00
No-Hub (2005)	Y02, Y03, Y04		4"	N/C

OPTIONS:	ADD
-ARI Acid Resistant Inside or Outside	132.00
-ARIO Acid Resistant Inside & Outside	132.00
-BB Bronze Body, 02-04"	952.00
05-06"	2,927.00
-BFV Ball Float Backwater Valve	298.00
-DID Drain Installation Device	See Fig. 2038
-G Galvanized Body	154.00
-P Trap Primer Conn	N/C
-U Vandal Proof Screws	43.00
-V Flapper Type Backwater Valve	298.00

A OUTLET SIZE	B STRAINER SIZE	X MIN MAX	DUCO CI PB TOP	DUCO CI †NB TOP	DUCO CI CP TOP	APPROX. WEIGHT LBS.
02, 03, 04"	05"	1 1/4 2 1/4	641.00	685.00	738.00	13
02, 03, 04"	06"	1 1/4 2 1/4	673.00	761.00	822.00	14
02, 03, 04"	07"	1 1/4 2 1/4	984.00	1,098.00	1,194.00	16
02, 03, 04"	08"	1 1/2 2 1/2	1,027.00	1,112.00	1,213.00	16

REGULARLY FURNISHED: Duco Cast Iron Body and Flashing Collar, Adjustable Strainer Head as Indicated by Suffix Letter Selected.

When ordering, specify drain body and strainer type, size and finish. Ex. 2005Y04 w/A05NB.

†REGULARLY FURNISHED

FLOOR DRAINS

SMITH®



CUSTOMER DRIVEN SINCE 1926

FIG. 2005 (-J) FLOOR DRAIN AND ADJ. STRAINER WITH ROUND SPANNER WRENCH COVER
FIG. 2010 (-J) FLOOR DRAIN AND ADJ. STRAINER WITH ROUND SPANNER WRENCH COVER

FUNCTION: Solid gas tight, vandal proof, threaded cover for areas where intermittent drain use is required.

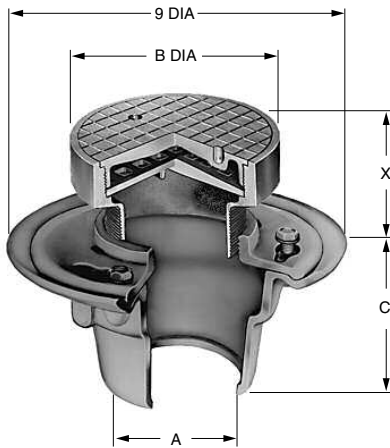

A OUTLET SIZE	B STRAINER SIZE	X MIN	X MAX	DUCO CI PB TOP	DUCO CI †NB TOP	DUCO CI CP TOP	APPROX. WEIGHT LBS.
02, 03, 04"	06"	2	3	834.00	892.00	967.00	19

REGULARLY FURNISHED: Duco Cast Iron Body and Flashing Collar, Adjustable Strainer Head as Indicated by Suffix Letter Selected.

OUTLET VARIATIONS (Specify type of outlet and pipe size in inches.)

Outlet Type	Outlet Designation	Outlet Type/Pipe Size	"C" Body HT. DIM.	ADD
Inside Caulk (2010)	C02, C03, C04		4"	N/C
Speedi-Set SW (2005)	L02, L03, L04		4"	N/C
Speedi-Set XH (2005)	LXH02, LXH03, LXH04		4"	N/C
Threaded(2010)	T02, T03, T04		3"	61.00
No-Hub (2005)	Y02, Y03, Y04		4"	N/C

OPTIONS:	ADD
-ARI Acid Resistant Inside or Outside	132.00
-ARIO Acid Resistant Inside & Outside	132.00
-B Sediment Bucket	85.00
-BB Bronze Body, 02-04"	952.00
05-06"	2,927.00
-BFV Ball Float Backwater Valve	298.00
-DID Drain Installation Device	See Fig. 2038
-G Galvanized Body	154.00
-P Trap Primer Conn	N/C
-SC Smooth Cover	161.00
-SW Spanner Wrench	109.00
-V Flapper Type Backwater Valve	298.00

FIG. 2005 (-K) FLOOR DRAIN AND ADJ. STRAINER WITH SQUARE REINFORCED GRATE
FIG. 2010 (-K) FLOOR DRAIN AND ADJ. STRAINER WITH SQUARE REINFORCED GRATE

FUNCTION: Used in finished floors where some light wheeled traffic is anticipated.

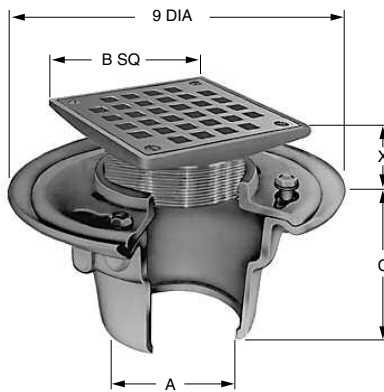

A OUTLET SIZE	B STRAINER SIZE	X MIN	X MAX	DUCO CI PB TOP	DUCO CI †NB TOP	DUCO CI CP TOP	APPROX. WEIGHT LBS.
02, 03, 04"	05 x 05"	1 1/4	2 1/4	554.00	592.00	640.00	14
02, 03, 04"	06 x 06"	1 1/4	2 1/4	658.00	695.00	746.00	16
02, 03, 04"	07 x 07"	1 1/4	2 1/4	757.00	794.00	853.00	17
02, 03, 04"	08 x 08"	1 1/2	2 1/2	907.00	978.00	1,062.00	18

REGULARLY FURNISHED: Duco Cast Iron Body and Flashing Collar, Adjustable Strainer Head as Indicated by Suffix Letter Selected.

OUTLET VARIATIONS (Specify type of outlet and pipe size in inches.)

Outlet Type	Outlet Designation	Outlet Type/Pipe Size	"C" Body HT. DIM.	ADD
Inside Caulk (2010)	C02, C03, C04		4"	N/C
Speedi-Set SW (2005)	L02, L03, L04		4"	N/C
Speedi-Set XH (2005)	LXH02, LXH03, LXH04		4"	N/C
Threaded (2010)	T02, T03, T04		3"	61.00
No-Hub (2005)	Y02, Y03, Y04		4"	N/C

OPTIONS:	ADD
-ARI Acid Resistant Inside or Outside	132.00
-ARIO Acid Resistant Inside & Outside	132.00
-B Sediment Bucket	85.00
-BB Bronze Body, 02-04"	952.00
05-06"	2,927.00
-BFV Ball Float Backwater Valve	298.00
-DID Drain Installation Device	See Fig. 2038
-G Galvanized Body	154.00
-P Trap Primer Conn	N/C
-U Vandal Proof Screws	43.00
-V Flapper Type Backwater Valve	298.00

When ordering, specify drain body and strainer type, size and finish. Ex. 2005Y04 w/A05NB.

†REGULARLY FURNISHED

FLOOR DRAINS



FIG. 2005 (L-T) FLOOR DRAIN AND ADJ. STRAINER WITH RECTANGULAR GRATE FIG. 2010 (L-T) FLOOR DRAIN AND ADJ. STRAINER WITH RECTANGULAR GRATE

FUNCTION: Used in shower room, gutters and similar areas where large grate free area is required and limited width is available.

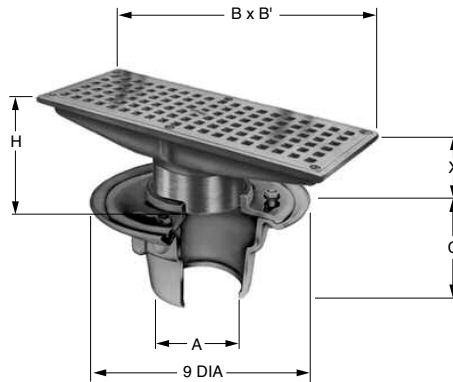

OUTLET VARIATIONS (Specify type of outlet and pipe size in inches.)

Outlet Type	Outlet Designation	Outlet Type/Pipe Size	"C" Body HT. DIM.	ADD
Inside Caulk (2010)	C02, C03, C04		4"	N/C
Speedi-Set SW (2005)	L02, L03, L04		4"	N/C
Speedi-Set XH (2005)	LXH02, LXH03, LXH04		4"	N/C
Threaded(2010)	T02, T03, T04		3"	61.00
No-Hub (2005)	Y02, Y03, Y04		4"	N/C

OPTIONS:

Option	Description	ADD
-ARI	Acid Resistant Inside or Outside	132.00
-ARIO	Acid Resistant Inside & Outside	132.00
-B	Sediment Bucket	85.00
-BB	Bronze Body, 02-04"	952.00
	05-06"	2,927.00
-BFV	Ball Float Backwater Valve	298.00
-DID	Drain Installation Device	See Fig. 2038
-G	Galvanized Body	154.00
-P	Trap Primer Conn	N/C
-U	Vandal Proof Screws	43.00
-V	Flapper Backwater Valve	298.00

A OUTLET SIZE	STRAINER SUFFIX	B X B STRAINER SIZE	X MIN MAX	H	DUCO CI PB TOP	DUCO CI †NB TOP	DUCO CI CP TOP	APPROX. WEIGHT LBS.
02, 03, 04"	L	4 1/4 x 08"	1 3/8" 2 3/8"	2 1/4"	776.00	834.00	903.00	17
02, 03, 04"	M	04 x 12"	1 7/8" 2 3/4"	2 1/2"	879.00	1,007.00	1,092.00	19
02, 03, 04"	N	05 x 09"	1 3/8" 2 3/8"	2 1/4"	776.00	834.00	903.00	21
02, 03, 04"	P	05 x 13"	2 1/8" 3"	3"	1,027.00	1,131.00	1,226.00	24
02, 03, 04"	R	06 x 10"	1 3/8" 2 3/8"	2 1/4"	1,027.00	1,131.00	1,226.00	26
02, 03, 04"	T	05 x 17"	2 1/4" 3 1/8"	3"	1,098.00	1,204.00	1,308.00	29

REGULARLY FURNISHED: Duco Cast Iron Body and Flashing Collar, Adjustable Strainer Head as Indicated by Suffix Letter Selected.

FIG. 2005 (-V) FLOOR DRAIN AND ADJ. STRAINER WITH ANGLE GRATE FIG. 2010 (-W) FLOOR DRAIN AND ADJ. STRAINER WITH ANGLE GRATE

FUNCTION: Shower room drain set at wall and floor junction. Vertical grate openings prevent drain stoppage should flat surface become covered.

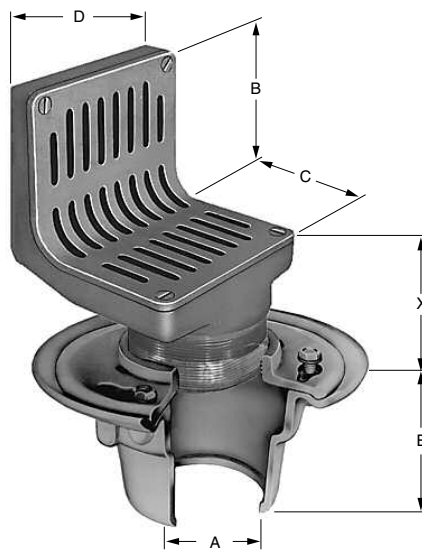

OUTLET VARIATIONS (Specify type of outlet and pipe size in inches.)

Outlet Type	Outlet Designation	Outlet Type/Pipe Size	"E" Body HT. DIM.	ADD
Inside Caulk (2010)	C02, C03, C04		4"	N/C
Speedi-Set SW (2005)	L02, L03, L04		4"	N/C
Speedi-Set XH (2005)	LXH02, LXH03, LXH04		4"	N/C
Threaded(2010)	T02, T03, T04		3"	61.00
No-Hub (2005)	Y02, Y03, Y04		4"	N/C

OPTIONS:

Option	Description	ADD
-ARI	Acid Resistant Inside or Outside	132.00
-ARIO	Acid Resistant Inside & Outside	132.00
-BB	Bronze Body, 02-04"	952.00
	05-06"	2,927.00
-DID	Drain Installation Device	See Fig. 2038
-G	Galvanized Body	154.00
-P	Trap Primer Conn	N/C
-U	Vandal Proof Screws	43.00

A OUTLET SIZE	STRAINER SUFFIX	B	C	D	X MIN MAX	DUCO CI PB TOP	DUCO CI †NB TOP	DUCO CI CP TOP	APPROX. WEIGHT LBS.
02, 03, 04"	V	3 1/2"	3 1/2"	4 1/2"	1 5/8" 2 5/8"	1,425.00	1,544.00	1,687.00	19
02, 03, 04"	W	6 3/4"	6 3/4"	6 1/2"	1 5/8" 2 5/8"	1,781.00	1,934.00	2,107.00	28

REGULARLY FURNISHED: Duco Cast Iron Body and Flashing Collar, Adjustable Strainer Head as Indicated by Suffix Letter Selected.

When ordering, specify drain body and strainer type, size and finish. Ex. 2005Y04 w/A05NB.

FLOOR DRAINS

FLOOR DRAINS

SMITH®



CUSTOMER DRIVEN SINCE 1926

FIG. 2005 (-Y) FLOOR DRAIN AND ADJ. STRAINER WITH OVERFLOW STANDPIPE FIG. 2010 (-Z) FLOOR DRAIN AND ADJ. STRAINER WITH OVERFLOW STANDPIPE

FUNCTION: Used as overflow drain in decorative pools, fish ponds or similar areas. Dome prevents floating objects from entering drain line.

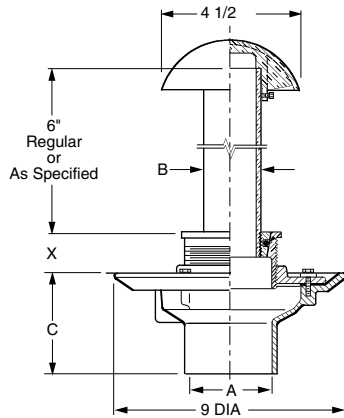

OUTLET VARIATIONS (Specify type of outlet and pipe size in inches.)

Outlet Type	Outlet Designation	Outlet Type/Pipe Size	"C" Body HT. DIM.	ADD
Inside Caulk (2010)	C02, C03, C04		4"	N/C
Speedi-Set SW (2005)	L02, L03, L04		4"	N/C
Speedi-Set XH (2005)	LXH02, LXH03, LXH04		4"	N/C
Threaded(2010)	T02, T03, T04		3"	61.00
No-Hub (2005)	Y02, Y03, Y04		4"	N/C

OPTIONS:

Option	Description	ADD
-ARI	Acid Resistant Inside or Outside	132.00
-ARIO	Acid Resistant Inside & Outside	132.00
-BB	Bronze Body, 02-04"	952.00
	05-06"	2,927.00
-DID	Drain Installation Device	See Fig. 2038
-G	Galvanized Body	154.00
-P	Trap Primer Conn	N/C

Higher Standpipe, over 6"	PB	NB	CP
per inch Y	76.00	107.00	113.00
per inch Z	132.00	151.00	162.00

A OUTLET SIZE	STRAINER SUFFIX	B STANDPIPE SIZE	X MIN	X MAX	DUCO CI PB TOP	DUCO CI †NB TOP	DUCO CI CP TOP	APPROX. WEIGHT LBS.
02, 03, 04"	Y	2	3/4	2 1/8	1,308.00	1,544.00	1,687.00	18
02, 03, 04"	Z	3	3/4	2 1/8	1,787.00	1,934.00	2,107.00	24

REGULARLY FURNISHED: Duco Cast Iron Body and Flashing Collar, Adjustable Strainer Head as Indicated by Suffix Letter Selected.

FIG. 2005 NO-HUB OUTLET FLOOR DRAIN BODY AND COLLAR ASSEMBLY

FUNCTION: General service floor drain for use in showers, toilets, kitchens and other finished areas where foot traffic is expected. Reversible flashing collar permits adjustment of the strainer to meet finished floor level.

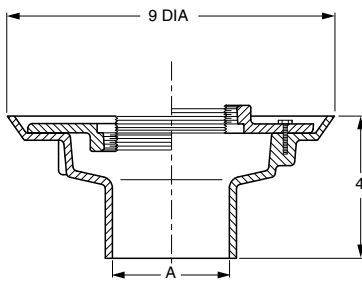

OUTLET VARIATIONS (Specify type of outlet and pipe size in inches.)

Outlet Type	Outlet Designation	Outlet Type/Pipe Size	Body HT. DIM.	ADD
Speedi-Set SW	L02, L03, L04		4"	N/C
Speedi-Set XH	LXH02, LXH03, LXH04		4"	N/C
No-Hub	Y02, Y03, Y04, Y05, Y06		4"	N/C

OPTIONS:

Option	Description	ADD
-ARI	Acid Resistant Inside or Outside	132.00
-ARIO	Acid Resistant Inside & Outside	132.00
-BB	Bronze Body, 02-04"	952.00
	05-06"	2,927.00
-DID	Drain Installation Device	See Fig. 2038
-P050	1/2" Trap Primer Conn	N/C
-P075	3/4" Trap Primer Conn	N/C

A OUTLET SIZE	COLLAR DIA	DUCO CI	GALV CI (-G)	APPROX. WEIGHT LBS.
02, 03, 04"	9	151.00	305.00	9
05, 06"	9	586.00	740.00	20

REGULARLY FURNISHED: Duco Cast Iron Body and Flashing Collar.

When ordering, specify drain body and strainer type, size and finish. Ex. 2005Y04 w/A05NB.

FLOOR DRAINS

FIG. 2010 CAULK OUTLET FLOOR DRAIN BODY AND COLLAR ASSEMBLY



FUNCTION: General service floor drain for use in showers, toilets, kitchens and other finished areas where foot traffic is expected. Reversible flashing collar permits adjustment of the strainer to meet finished floor level.

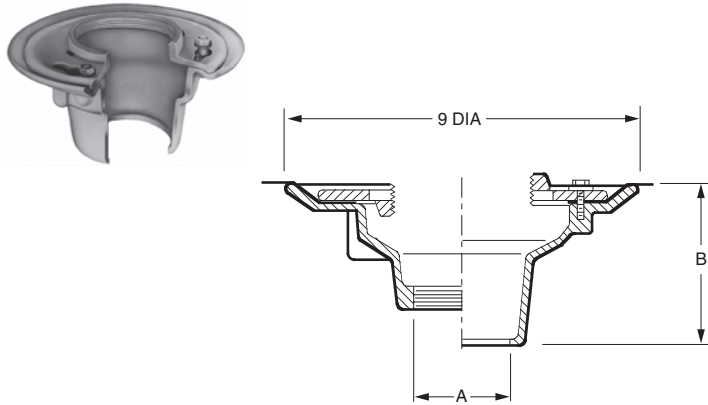

OUTLET VARIATIONS (Specify type of outlet and pipe size in inches.)

Outlet Type	Outlet Designation Outlet Type/Pipe Size	B Body HT. DIM.	ADD
Inside Caulk	C02, C03, C04, C05, C06	4"	N/C
Threaded	T02, T03, T04, T05, T06	3"	61.00

OPTIONS:

Option	Description	ADD
-ARI	Acid Resistant Inside or Outside	132.00
-ARIO	Acid Resistant Inside & Outside	132.00
-BB	Bronze Body, 02-04"	952.00
	05-06"	2,927.00
-P050	1/2" Trap Primer Conn.	N/C
-P075	3/4" Trap Primer Conn.	N/C

A OUTLET SIZE	COLLAR DIA	†DUCO CI	GALV CI (-G)	APPROX. WEIGHT LBS.
02, 03, 04"	9"	151.00	305.00	9
05, 06"	9"	586.00	740.00	20

REGULARLY FURNISHED: Duco Cast Iron Body and Flashing Collar.

Note: For body with adjustable strainer head and 4" DIA funnel see Figure 3510-F11.

FIG. 2015 SIDE OUTLET FLOOR DRAIN BODY AND COLLAR ASSEMBLY

FUNCTION: General service side outlet floor drain for use in showers, toilets, kitchens and other finished areas where foot traffic is expected.

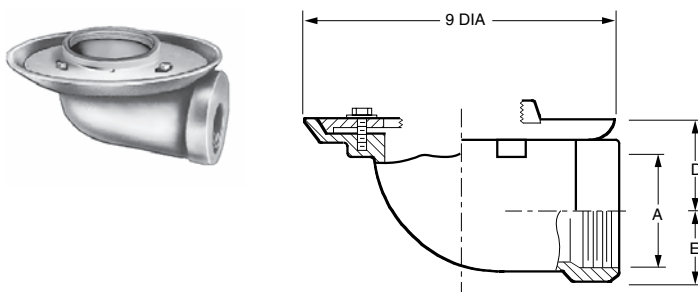

OUTLET VARIATIONS (Specify type of outlet and pipe size in inches.)

Outlet Type	Outlet Designation Outlet Type/Pipe Size	ADD
Inside Caulk	C04	N/C
Threaded	T02, T03, T04	N/C

OPTIONS:

Option	Description	ADD
-P050	1/2" Trap Primer Conn	N/C
-P075	3/4" Trap Primer Conn	N/C

A OUTLET SIZE	COLLAR DIA	D	E	†DUCO CI	GALV. CI (-G)	APPROX. WEIGHT LBS.
02"	9"	2 3/4"	1 1/4"	323.00	477.00	12
03"	9"	2 3/4"	2 1/4"	323.00	477.00	12
04"	9"	3 1/4"	3 1/4"	395.00	549.00	13

REGULARLY FURNISHED: Duco Cast Iron Body and Flashing Collar.

Note: For body with adjustable strainer head and 4" DIA funnel see Fig. 3515-F11.