

# IECHO Blade Catalog

## 一.Kiss Cut Tool

### 1.E1

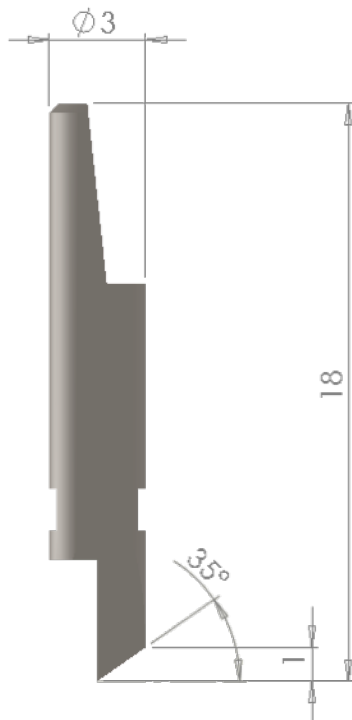

Name: E1

Raw Material: Tungsten Steel

Blade Diameter: 3mm

Cutting Thickness: 0.8mm

Applicable Tool: Kiss Cut Tool

Applicable Industry: Sign & Graphics、Label

Applicable Material: Vinyl、Cardboard、3M、Reflective Material

Price: USD25/PC

**2.E2**

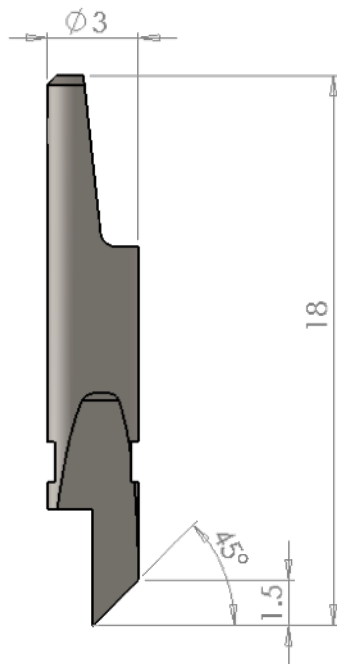

Name: E2

Raw Material: Tungsten Steel

Blade Diameter: 3mm

Cutting Thickness: 1.5mm

Applicable Tool: Kiss Cut Tool

Applicable Industry: Sign & Graphics、Label

Applicable Material: Vinyl、Cardboard、3M、Reflective Material

Price: USD25/PC

## 二. Tangent Tool (Drag Knife)

### 1. E13C

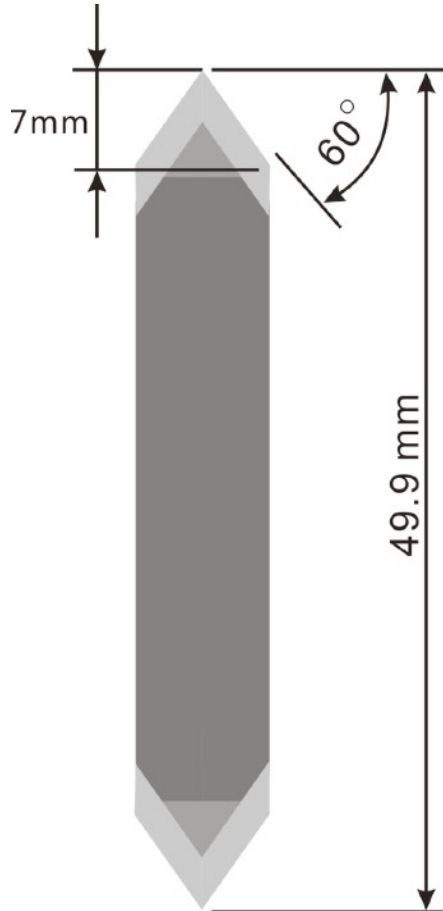

Name: E13C

Raw Material: Tungsten Steel

Blade Thickness: 1.5mm

Cutting Thickness: 7.0mm

Applicable Tool: Tangent Tool (Drag Knife)

Applicable Industry: Sign & Graphics, Label, Composites, Automotive

Applicable Material: Vinyl, Cardboard, Chevron Board, ABS BOARD, Gasket, 3M, Reflective Material, Prepreg, PVC mesh, PE, XPE.

Price: USD25/PC

**2.E14C**

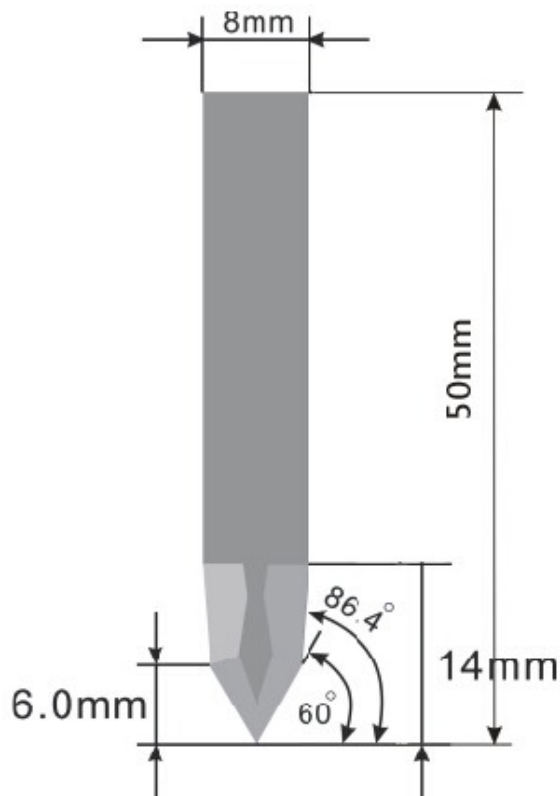

Name: E14C

Raw Material: Tungsten Steel

Blade Thickness: 1.5mm

Cutting Thickness: 14mm

Applicable Tool: Tangent Tool (Drag Knife)

Applicable Industry: Sign & Graphics, Label, Composites, Automotive

Applicable Material: Vinyl, Cardboard, Chevron Board, ABS BOARD, Gasket, 3M, Reflective Material, Prepreg, PVC mesh, PE, XPE.

Price: USD20/PC

**ET1**

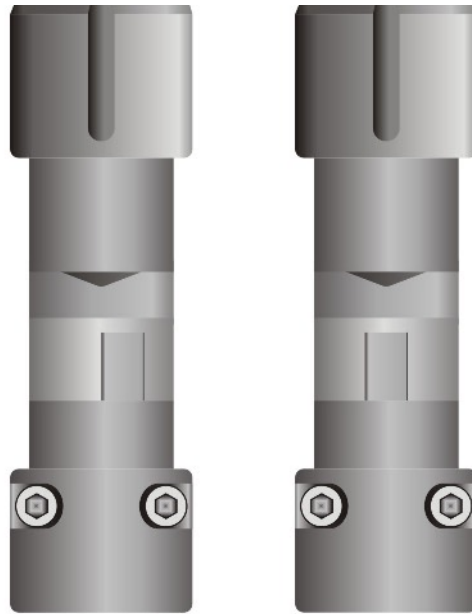
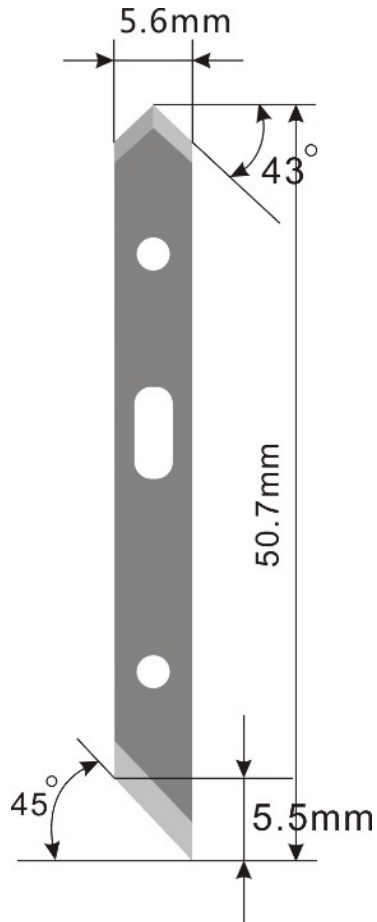

0.63mm偏心刀座 0.63mm中心刀座

Name: ET1

Raw Material: Carbon Steel

Blade Thickness: 0.63mm

Cutting Thickness: 2.5mm-5.5mm

Applicable Tool: Tangent Tool (Drag Knife)

Applicable Industry: Sign & Graphics、Label、Composites

Applicable Material: Vinyl、Cardboard、Chevron Board、Gasket、3M、Reflective Material、Prepreg、PVC mesh.

Special design blade

### 三.Oscillating Tool

#### 1.E16C

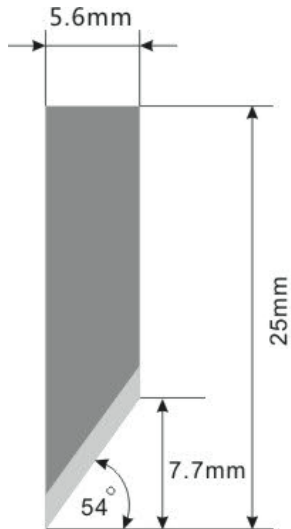

Name: E16C

Raw Material: Tungsten Steel

Blade Thickness: 0.63mm

Cutting Thickness: 7.7mm

Applicable Tool: Tangent Tool (Drag Knife) 、 Oscillating Tool

Applicable Industry: Sign & Graphics、 Label、 Composites、  
Automotive

Applicable Material: Vinyl、 Cardboard、 Chevron Board、 ABS  
BOARD、 Corrugated、 Gasket、 3M、 Reflective Material、 Prepreg、  
PVC mesh、 PE、 XPE、 PU LEATHER、 PU COMPOSITE SPONG、  
Genuine Leather.

Price: USD10/PC

**2.E16-2C**

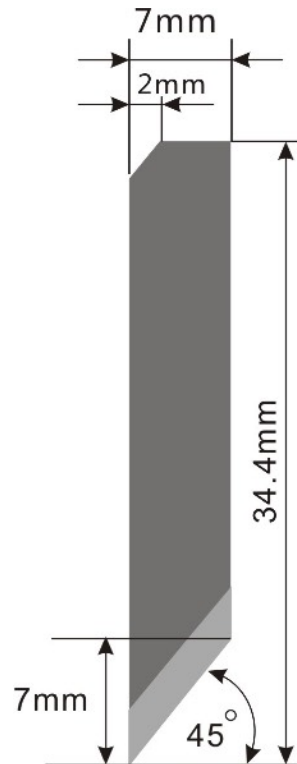

Name: E16-2C

Raw Material: Tungsten Steel

Blade Thickness: 1.0mm

Cutting Thickness: 7.0mm

Applicable Tool: Oscillating Tool

Applicable Industry: Sign & Graphics、Composites

Applicable Material: Chevron Board、ABS BOARD、Gasket、3M、  
Reflective Material、Prepreg、PVC mesh.

Price: USD10/PC

**3.E17C**

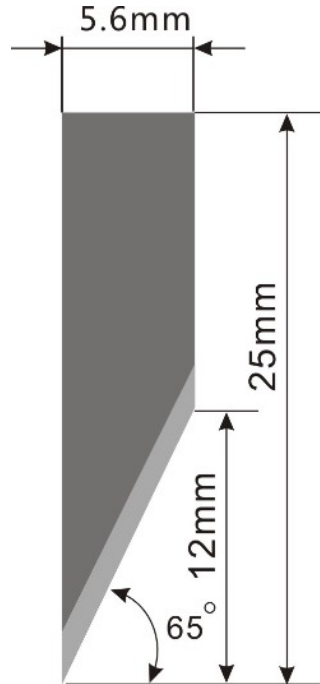

Name: E17C

Raw Material: Tungsten Steel

Blade Thickness: 0.63mm

Cutting Thickness: 12.0mm

Applicable Tool: Tangent Tool (Drag Knife) 、 Oscillating Tool

Applicable Industry: Sign & Graphics、 Composites、 Automotive

Applicable Material: Vinyl、 Cardboard、 Chevron Board、 ABS

BOARD、 Corrugated、 Gasket、 3M、 Reflective Material、 Prepreg、

PVC mesh、 PE、 XPE、 PU LEATHER、 PU COMPOSITE SPONG、

Genuine Leather.

Price: USD10/PC

**4.E17LC**

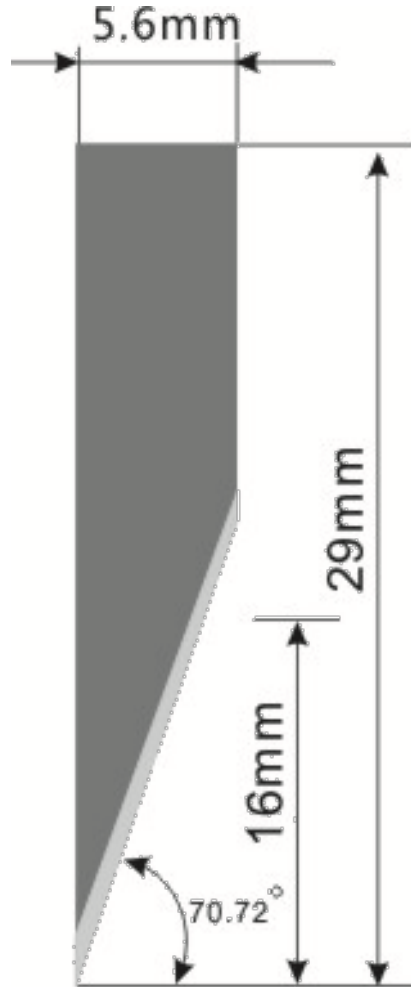

Name: E17LC

Raw Material: Tungsten Steel

Blade Thickness: 0.63mm

Cutting Thickness: 16mm

Applicable Tool: Oscillating Tool

Applicable Industry: Sign & Graphics、Composites、Automotive

Applicable Material: Chevron Board、Corrugated、Gasket、PE、XPE、PU LEATHER、PU COMPOSITE SPONG、Coil Car Mat.

Price: USD15/PC

**5.E18C**

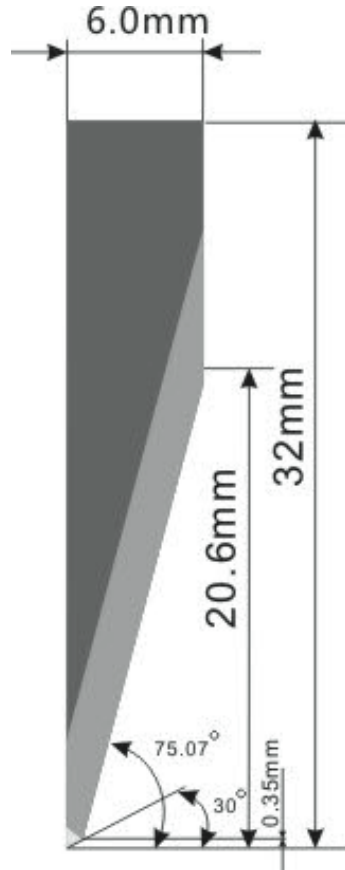

Name: E18C

Raw Material: Tungsten Steel

Blade Thickness: 0.63mm

Cutting Thickness: 19mm

Applicable Tool: Oscillating Tool

Applicable Industry: Sign & Graphics、Composites、Automotive

Applicable Material: Chevron Board、Corrugated、Gasket、PE、XPE、PU LEATHER、PU COMPOSITE SPONG、Coil Car Mat.

Price: USD10/PC

**6.E18LC**

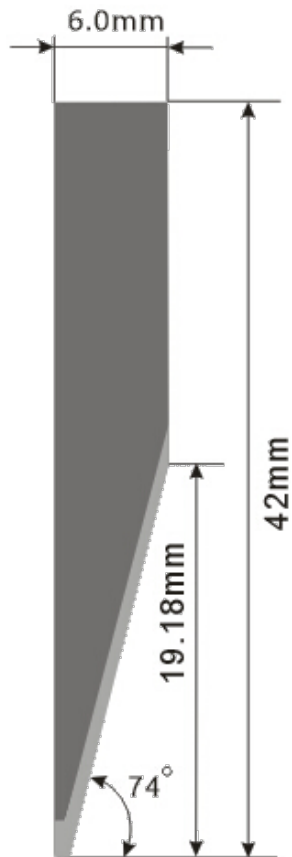

Name: E18LC

Raw Material: Tungsten Steel

Blade Thickness: 1mm

Cutting Thickness: 19mm

Applicable Tool: Oscillating Tool

Applicable Industry: Sign & Graphics、Composites、Automotive

Applicable Material: Chevron Board、Corrugated、Gasket、PE、XPE、PU LEATHER、PU COMPOSITE SPONG、Coil Car Mat.

Price: USD10/PC

**7. E20C**

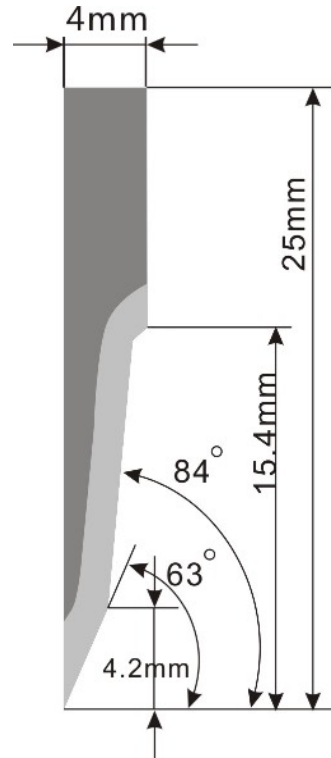

Name: E20C

Raw Material: Tungsten Steel

Blade Thickness: 0.63mm

Cutting Thickness: 11mm

Applicable Tool: Oscillating Tool

Applicable Industry: Sign & Graphics、Packaging

Applicable Material: Chevron Board、Corrugated、KT BOARD、Vertical Corrugated、EPE Foam、EVA.

Price: USD15/PC

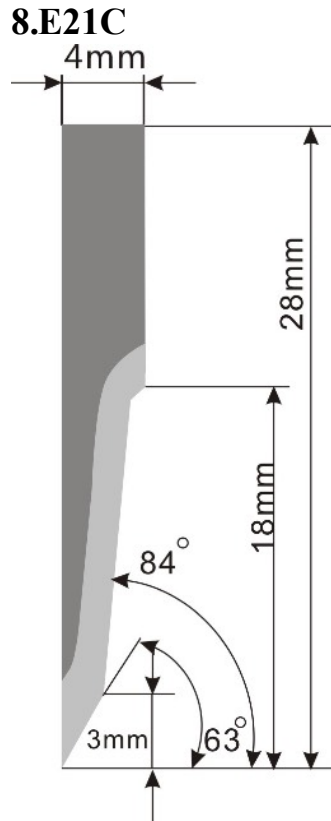

Name: E21C

Raw Material: Tungsten Steel

Blade Thickness: 0.63mm

Cutting Thickness: 14mm

Applicable Tool: Oscillating Tool

Applicable Industry: Sign & Graphics、Packaging

Applicable Material: Chevron Board、Corrugated、KT BOARD、Vertical Corrugated、EPE Foam、EVA.

Price: USD10/PC

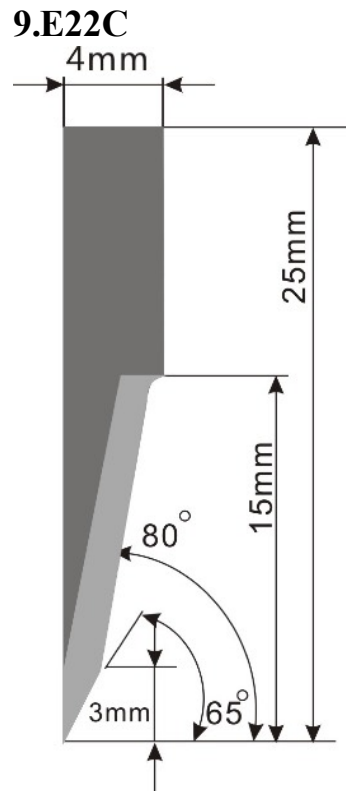

Name: E22C

Raw Material: Tungsten Steel

Blade Thickness: 0.63mm

Cutting Thickness: 11mm

Applicable Tool: Oscillating Tool

Applicable Industry: Sign & Graphics、Packaging

Applicable Material: Chevron Board、Corrugated、KT BOARD、Vertical Corrugated、EPE Foam、EVA、Gray cardboard.

Price: USD15/PC

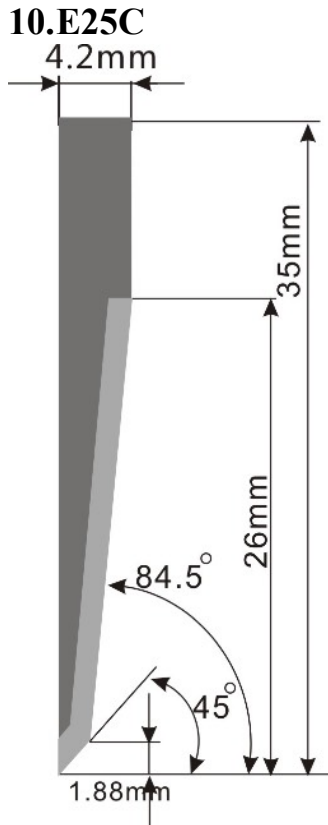

Name: E25C

Raw Material: Tungsten Steel

Blade Thickness: 1.0mm

Cutting Thickness: 21mm

Applicable Tool: Oscillating Tool

Applicable Industry: Sign & Graphics、Packaging、Automotive

Applicable Material: Corrugated、Vertical Corrugated、EPE Foam、Coil Car Mat.

Price: USD10/PC

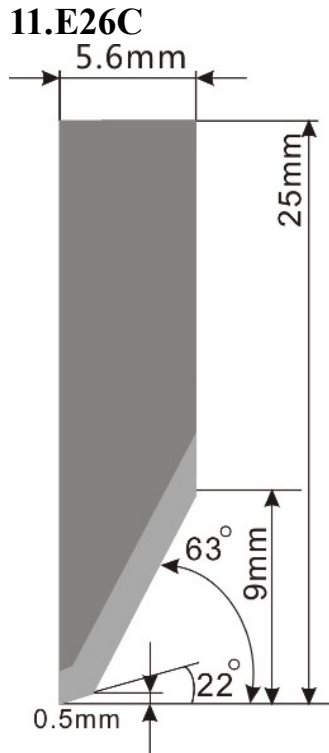

Name: E26C

Raw Material: Tungsten Steel

Blade Thickness: 0.63mm

Cutting Thickness: 9.0mm

Applicable Tool: Tangent Tool (Drag Knife) 、 Oscillating Tool

Applicable Industry: Automotive、 Composites

Applicable Material: PU、 PU COMPOSITE SPONG、 Genuine Leather、 XPE、 EVA、 Prepreg.

Price: USD10/PC

**12.E26-2C**

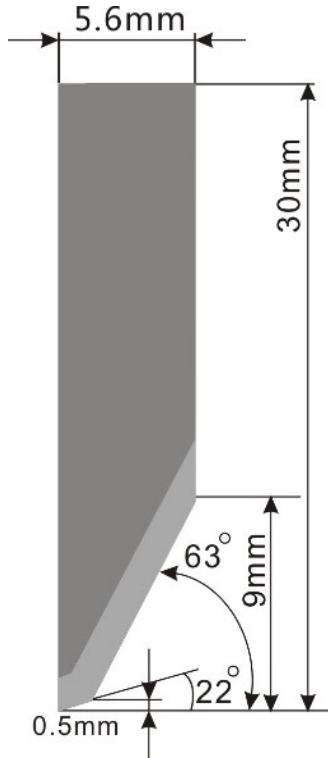

Name: E26-2C

Raw Material: Tungsten Steel

Blade Thickness: 0.63mm

Cutting Thickness: 9.0mm

Applicable Tool: Tangent Tool (Drag Knife) 、 Oscillating Tool

Applicable Industry: Automotive、 Composites

Applicable Material: PU、 PU COMPOSITE SPONG、 Genuine Leather、 XPE、 EVA、 Prepreg.

Price: USD10/PC

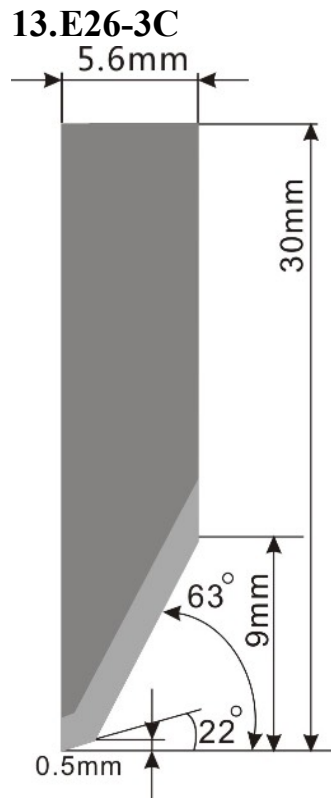

Name: E26-3C

Raw Material: Tungsten Steel

Blade Thickness: 1.0mm

Cutting Thickness: 9.0mm

Applicable Tool: Oscillating Tool

Applicable Industry: Automotive

Applicable Material: PU COMPOSITE SPONGE

Price: USD15/PC

### 14.E26-4C

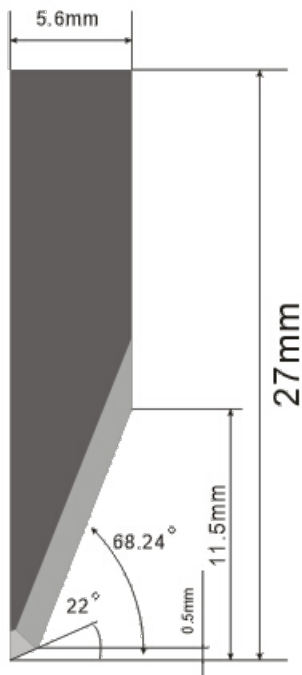

Name: E26-4C

Raw Material: Tungsten Steel

Blade Thickness: 0.63mm

Cutting Thickness: 10mm

Applicable Tool: Oscillating Tool

Applicable Industry: Automotive

Applicable Material: PU COMPOSITE SPONGE、carbon fiber

Price: USD15/PC

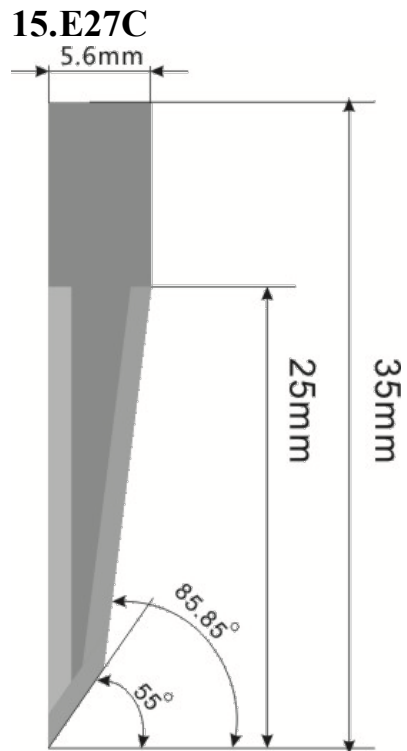

Name: E27C

Raw Material: Tungsten Steel

Blade Thickness: 0.63mm

Cutting Thickness: 25mm

Applicable Tool: Oscillating Tool

Applicable Industry:

Applicable Material:

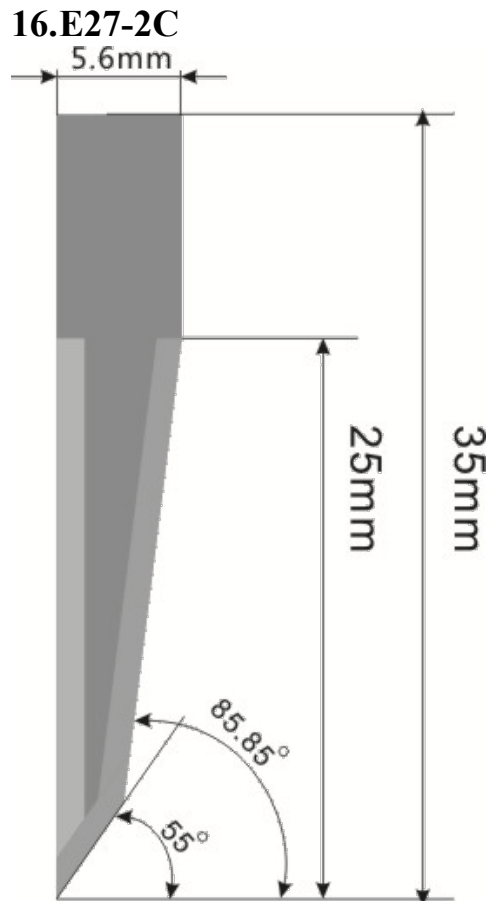

Name: E27-2C

Raw Material: Tungsten Steel

Blade Thickness: 1mm

Cutting Thickness: 25mm

Applicable Tool: Oscillating Tool

Applicable Industry:

Applicable Material:

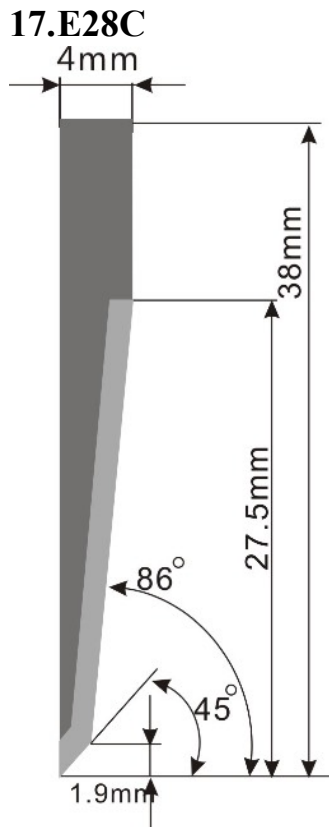

Name: E28C

Raw Material: Tungsten Steel

Blade Thickness: 0.63mm

Cutting Thickness: 24mm

Applicable Tool: Oscillating Tool

Applicable Industry: Sign & Graphics、Packaging

Applicable Material: KT BOARD、EVA、EPE Foam、Vertical Corrugated.

Price: USD10/PC

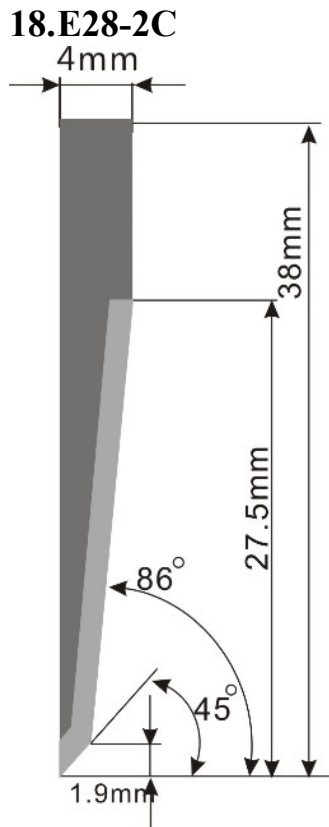

Name: E28-2C

Raw Material: Tungsten Steel

Blade Thickness: 1.0mm

Cutting Thickness: 24mm

Applicable Tool: Oscillating Tool

Applicable Industry: Sign & Graphics、Packaging

Applicable Material: KT BOARD、EVA、EPE Foam、Vertical Corrugated.

Price: USD10/PC

**19.E41C**

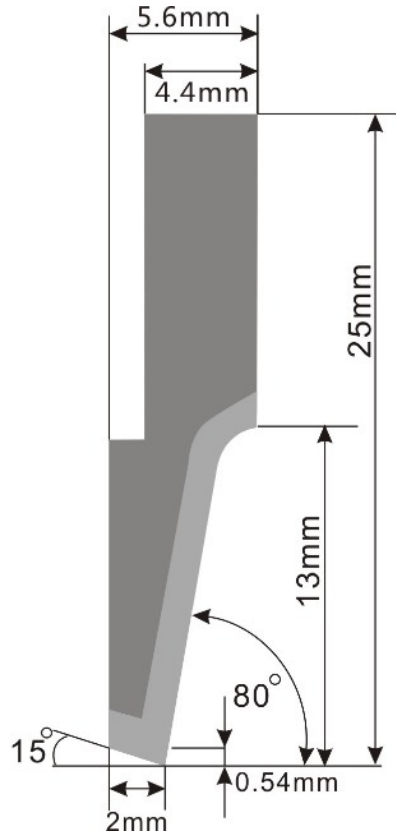

Name: E41C

Raw Material: Tungsten Steel

Blade Thickness: 0.63mm

Cutting Thickness: 11mm

Applicable Tool: Oscillating Tool

Applicable Industry: Luggage、Automotive、Footwear、Furniture

Applicable Material: Genuine Leather、PU.

Price: USD10/PC

**20.E42C**

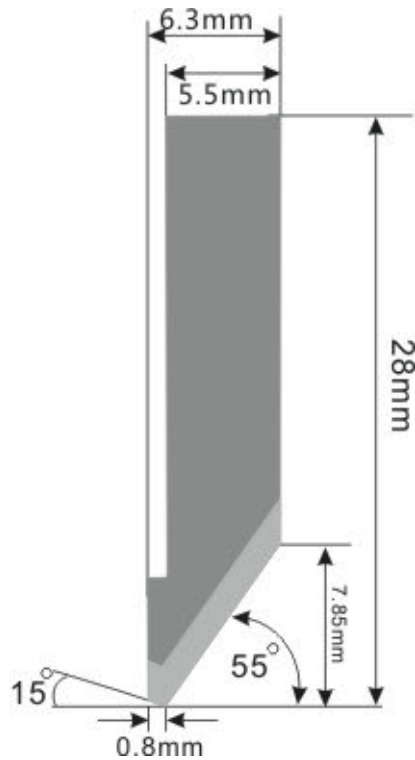

Name: E42C

Raw Material: Tungsten Steel

Blade Thickness: 0.63mm

Cutting Thickness: 7.5mm

Applicable Tool: Oscillating Tool

Applicable Industry: Luggage、Automotive、Footwear、Furniture

Applicable Material: Genuine Leather、PU.

Price: USD10/PC

**21.E46C**

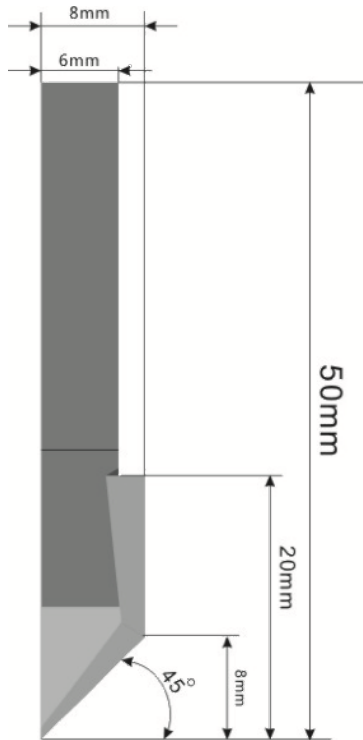

Name: E46C

Raw Material: Tungsten Steel

Blade Thickness: 1.5mm

Cutting Thickness: 20mm

Applicable Tool: Oscillating Tool

Applicable Industry: Sign & Graphics、Composites

Applicable Material: KT BOARD、Chevron Board, Prepreg.

Price: USD25/PC

#### 四. Rotary Tool

##### 1. E50C

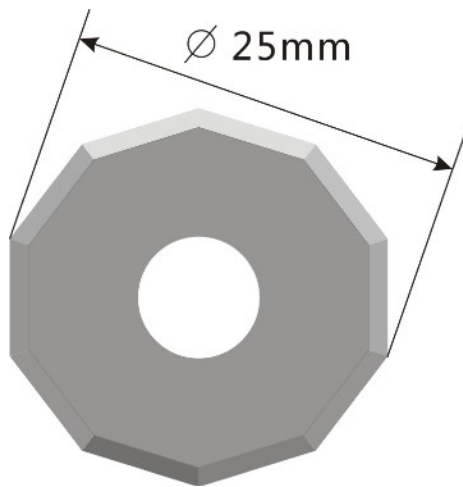

Name: E50C

Raw Material: Tungsten Steel

Blade Thickness: 0.63mm

Cutting Thickness: 4.0mm

Applicable Tool: Rotary Tool

Applicable Industry: Luggage、Automotive、Furniture、Composites、Garment

Applicable Material: Fabric、Carbon Fiber、Glass Fiber、Kevlar、Carpet.

Price: USD25/PC

**2.E51C**

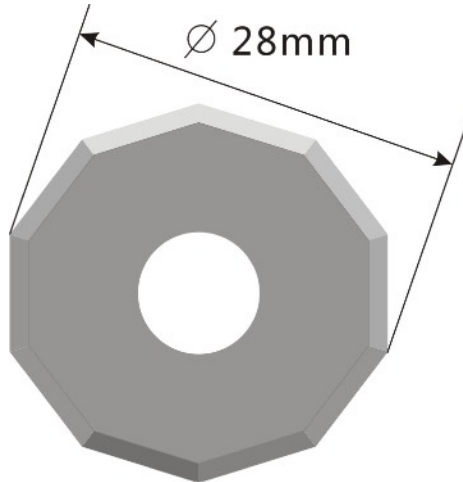

Name: E51C

Raw Material: Tungsten Steel

Blade Thickness: 0.63mm

Cutting Thickness: 5.5mm

Applicable Tool: Rotary Tool

Applicable Industry: Luggage、Automotive、Furniture、Composites、Garment

Applicable Material: Fabric、Carbon Fiber、Glass Fiber、Kevlar、Carpet.

Price: USD25/PC

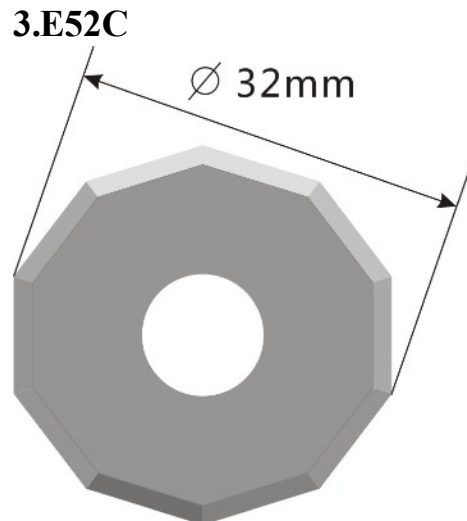

Name: E52C

Raw Material: Tungsten Steel

Blade Thickness: 0.63mm

Cutting Thickness: 7.5mm

Applicable Tool: Rotary Tool

Applicable Industry: Luggage、Automotive、Furniture、Composites、Garment

Applicable Material: Fabric、Carbon Fiber、Glass Fiber、Kevlar、Carpet.

Price: USD25/PC

4.E53C

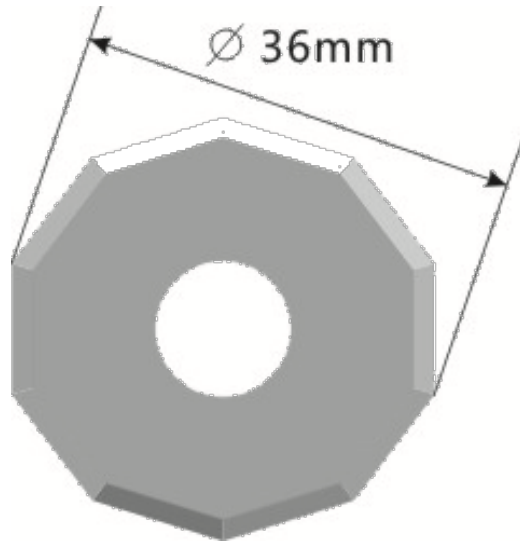

Name: E53C

Raw Material: Tungsten Steel

Blade Thickness: 0.63mm

Cutting Thickness: 9.5mm

Applicable Tool: Rotary Tool

Applicable Industry: Luggage、Automotive、Furniture、Composites、Garment

Applicable Material: Fabric、Carbon Fiber、Glass Fiber、Kevlar、Carpet.

Price: USD25/PC

5.E55C

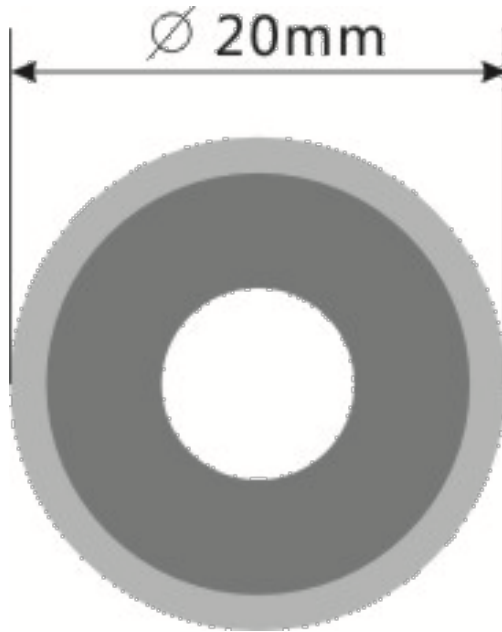

Name: E55C

Raw Material: Tungsten Steel

Blade Thickness: 0.63mm

Cutting Thickness: 2mm

Applicable Tool: Rotary Tool

Applicable Industry: Luggage、Automotive、Furniture、Composites、Garment

Applicable Material: Fabric、Carbon Fiber、Glass Fiber、Kevlar、Carpet.

Price: USD25/PC

**6.E56C**

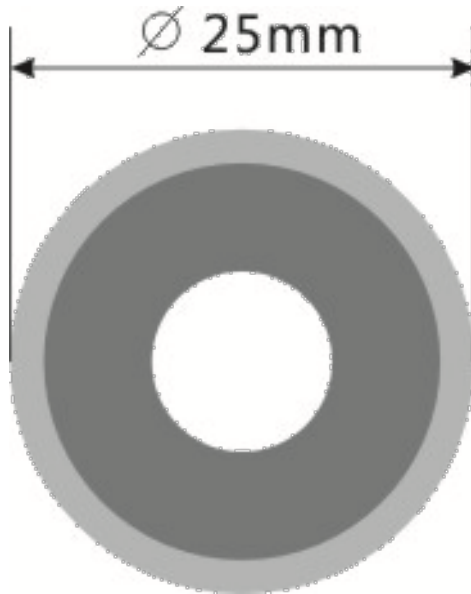

Name: E56C

Raw Material: Tungsten Steel

Blade Thickness: 0.63mm

Cutting Thickness: 4mm

Applicable Tool: Rotary Tool

Applicable Industry: Luggage、Automotive、Furniture、Composites、Garment

Applicable Material: Fabric、Carbon Fiber、Glass Fiber、Kevlar、Carpet.

Price: USD25/PC

7.E57C

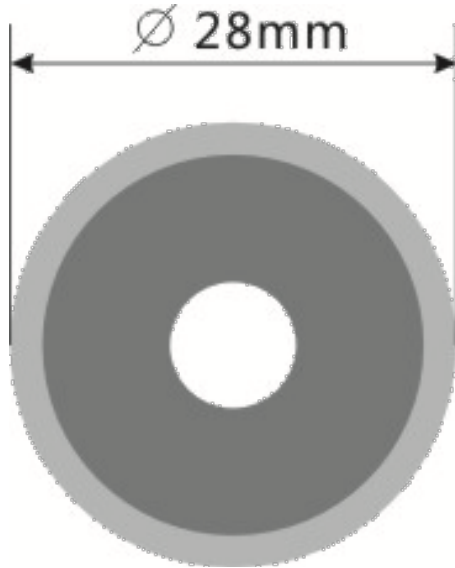

Name: E57C

Raw Material: Tungsten Steel

Blade Thickness: 0.63mm

Cutting Thickness: 5.5mm

Applicable Tool: Rotary Tool

Applicable Industry: Luggage、Automotive、Furniture、Composites、Garment

Applicable Material: Fabric、Carbon Fiber、Glass Fiber、Kevlar、Carpet.

Price: USD25/PC

8.E58C

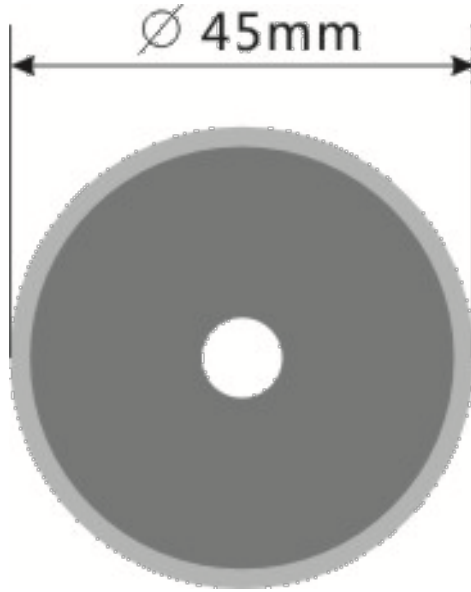

Name: E58C

Raw Material: Tungsten Steel

Blade Thickness: 0.63mm

Cutting Thickness: 14mm

Applicable Tool: Rotary Tool

Applicable Industry: Luggage、Automotive、Furniture、Composites、Garment

Applicable Material: Fabric、Carbon Fiber、Glass Fiber、Kevlar、Carpet.

Price: USD25/PC

## 五.Oscillating Tool-Lengthened Blades

### 1.E61C

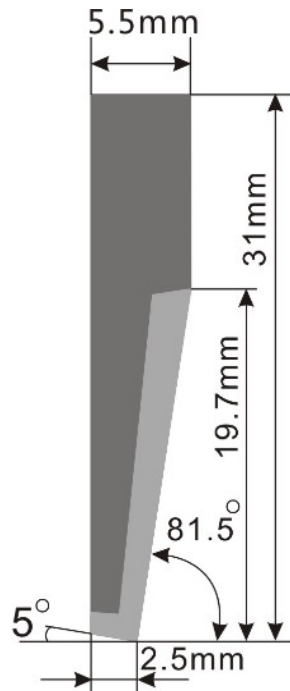

Name: E61C

Raw Material: Tungsten Steel

Blade Thickness: 1.0mm

Cutting Thickness: 17mm

Applicable Tool: Oscillating Tool

Applicable Industry: Sign & Graphics、Packaging

Applicable Material: Corrugated、Honeycomb Board、Vertical Corrugated.

Price: USD10/PC

**2.E64C**

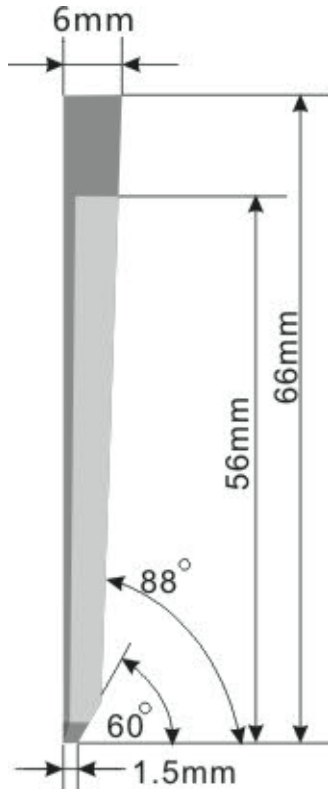

Name: E64C

Raw Material: Tungsten Steel

Blade Thickness: 1.5mm

Cutting Thickness: 52mm

Applicable Tool: Oscillating Tool

Applicable Industry: Sign & Graphics、Packaging

Applicable Material: Corrugated、Honeycomb Board、Vertical Corrugated、EPE Foam.

Price: USD25/PC

**3.E64-2C**

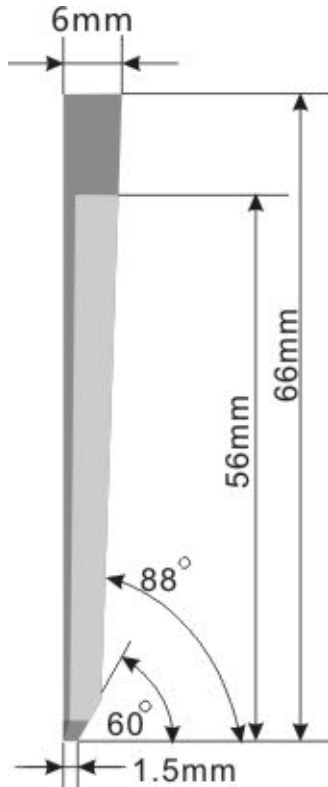

Name: E64-2C

Raw Material: Tungsten Steel

Blade Thickness: 1.0mm

Cutting Thickness: 52mm

Applicable Tool: Oscillating Tool

Applicable Industry: Sign & Graphics、Packaging

Applicable Material: Corrugated、Honeycomb Board、Vertical  
Corrugated、EPE Foam.

Price: USD25/PC

**4.E64-3C**

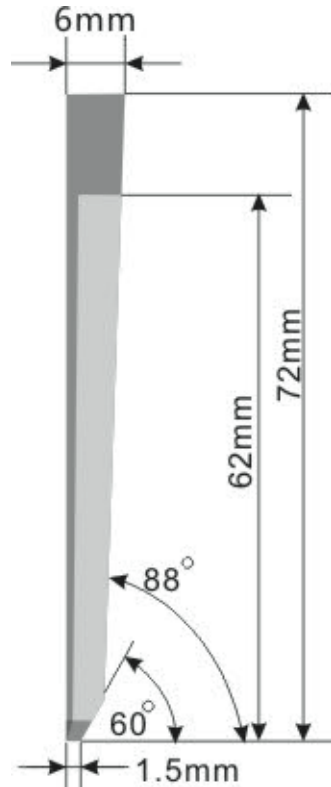

Name: E64-3C

Raw Material: Tungsten Steel

Blade Thickness: 1.0mm

Cutting Thickness: 58mm

Applicable Tool: Oscillating Tool

Applicable Industry: Sign & Graphics、Packaging

Applicable Material: Corrugated、Honeycomb Board、Vertical Corrugated、EPE Foam.

Price: USD25/PC

**5.E64-4C**

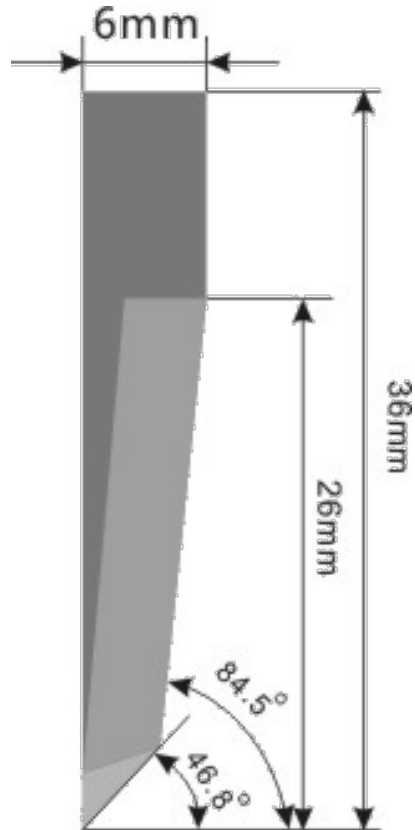

Name: E64-4C

Raw Material: Tungsten Steel

Blade Thickness: 1.0mm

Cutting Thickness: 26mm

Applicable Tool: Oscillating Tool

Applicable Industry: Sign & Graphics、Packaging、Automotive

Applicable Material: Corrugated、Honeycomb Board、Vertical Corrugated、EPE Foam、Coil Car Mat.

Price: USD25/PC

**6.E64-5C**

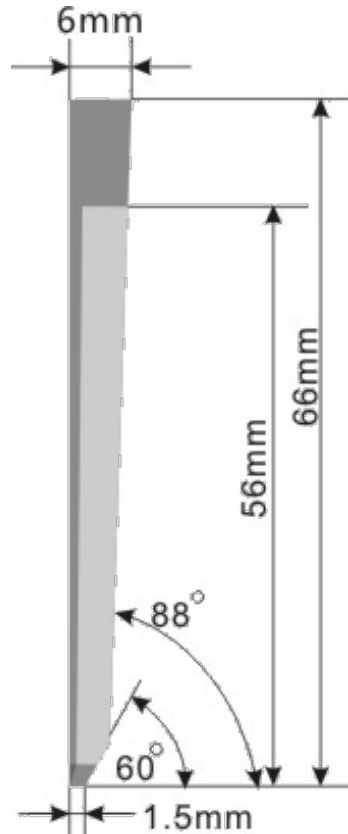

Name: E64-5C

Raw Material: High speed steel

Blade Thickness: 1.0mm

Cutting Thickness: 62mm

Applicable Tool: Oscillating Tool

Applicable Industry: Sign & Graphics、Packaging

Applicable Material: Corrugated、Honeycomb Board、Vertical Corrugated、EPE Foam.

Price: USD25/PC

**7.E64-6C**

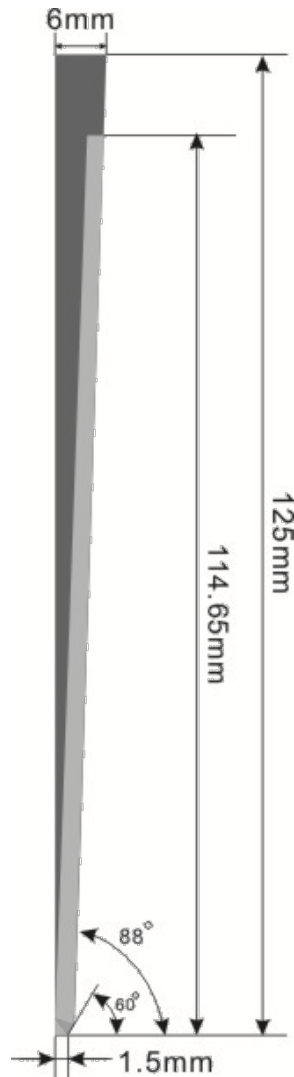

Name: E64-6C

Raw Material: Tungsten Steel

Blade Thickness: 1.0mm

Cutting Thickness: 110mm

Applicable Tool: Oscillating Tool

Applicable Industry: Sign & Graphics、Packaging

Applicable Material: Corrugated、Honeycomb Board、Vertical Corrugated、EPE Foam.

Price: USD25/PC

**8.E64-8C**

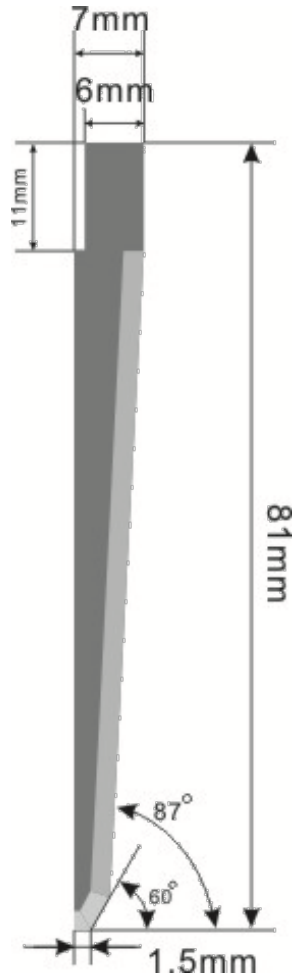

Name: E64-8C

Raw Material: Tungsten Steel

Blade Thickness: 1.0mm

Cutting Thickness: 70mm

Applicable Tool: Oscillating Tool

Applicable Industry: Sign & Graphics、Packaging

Applicable Material: Corrugated、Honeycomb Board、Vertical Corrugated、EPE Foam.

Price: USD25/PC

**9.E64-9C**

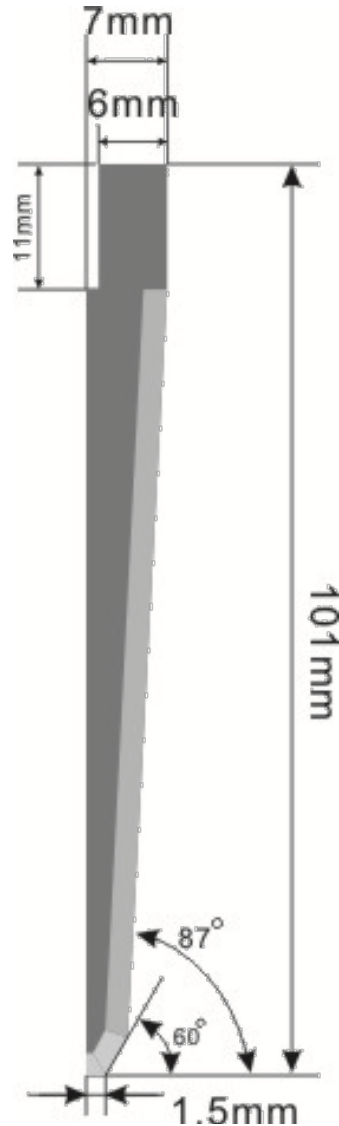

Name: E64-9C

Raw Material: Tungsten Steel

Blade Thickness: 1.0mm

Cutting Thickness: 90mm

Applicable Tool: Oscillating Tool

Applicable Industry: Sign & Graphics、Packaging

Applicable Material: Corrugated、Honeycomb Board、Vertical Corrugated、EPE Foam.

Price: USD25/PC

**10.E65C**

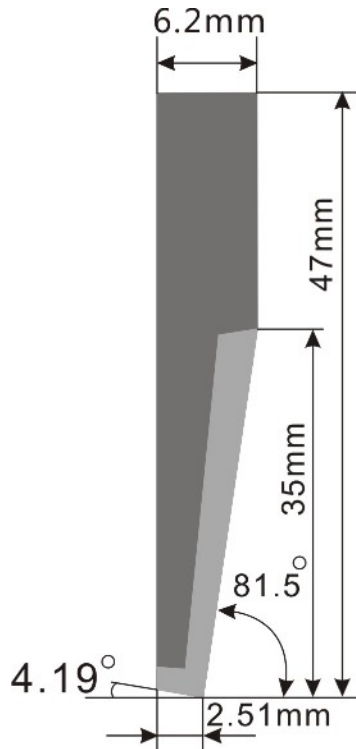

Name: E65C

Raw Material: Tungsten Steel

Blade Thickness: 1.0mm

Cutting Thickness: 33mm

Applicable Tool: Oscillating Tool

Applicable Industry: Sign & Graphics、Packaging

Applicable Material: Corrugated、Honeycomb Board、Vertical Corrugated.

Price: USD20/PC

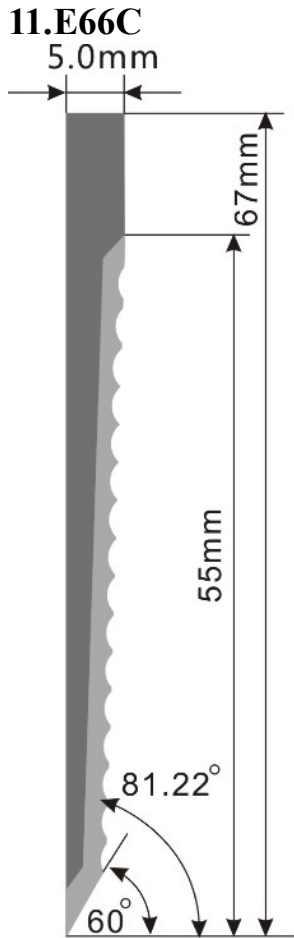

Name: E65C

Raw Material: Tungsten Steel

Blade Thickness: 1.5mm

Cutting Thickness: 53mm

Applicable Tool: Oscillating Tool

Applicable Industry: Sign & Graphics、Packaging

Applicable Material: Foam

Price: USD25/PC

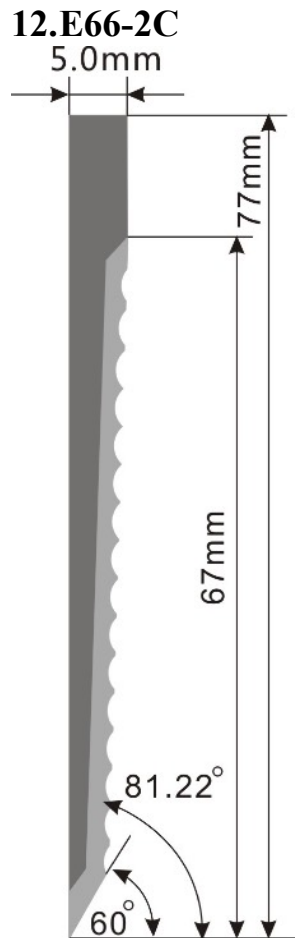

Name: E65C

Raw Material: Tungsten Steel

Blade Thickness: 1.0mm

Cutting Thickness: 63mm

Applicable Tool: Oscillating Tool

Applicable Industry: Sign & Graphics、Packaging

Applicable Material: Foam

Price: USD25/PC

## 六.V-Cut Tool

### 1.E71C

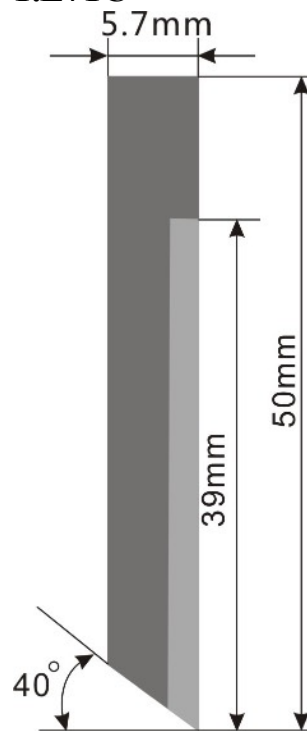

Name: E71C

Raw Material: Tungsten Steel

Blade Thickness: 1.0mm

Cutting Thickness: BK Standard Head 16mm

Applicable Tool: V-Cut

Applicable Industry: Sign & Graphics、Packaging

Applicable Material: Honeycomb Board、Vertical Corrugated.

Price: USD20/PC

**2.E71-2C**

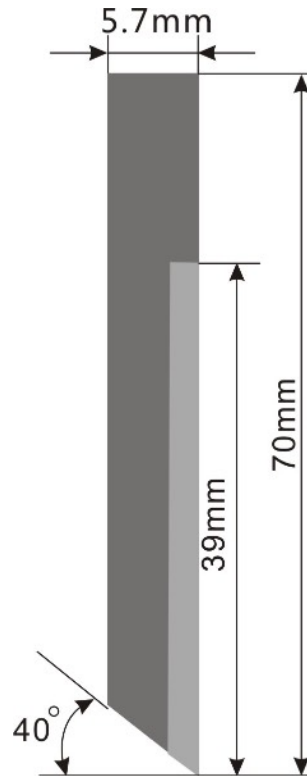

Name: E71-2C

Raw Material: Tungsten Steel

Blade Thickness: 1.0mm

Cutting Thickness: BKL、BK High Cutting Head 20mm

Applicable Tool: V-Cut

Applicable Industry: Sign & Graphics、Packaging

Applicable Material: Honeycomb Board、Vertical Corrugated.

Price: USD20/PC

**3.E73C**

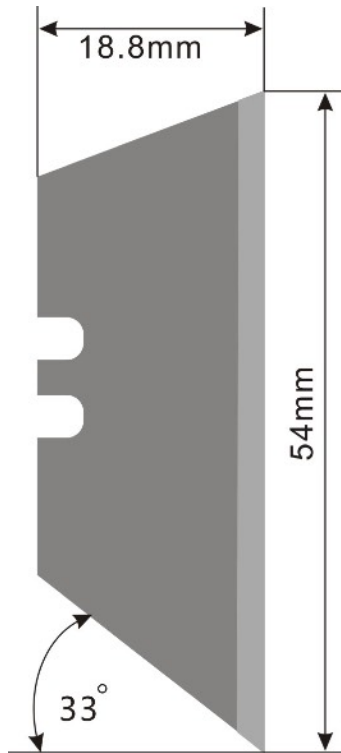

Name: E73C

Raw Material: Carbon Steel

Blade Thickness: 0.63mm

Cutting Thickness: 19mm

Applicable Tool: V-Cut

Applicable Industry: Sign & Graphics、Packaging

Applicable Material: Honeycomb Board、Vertical Corrugated、KT BOARD、Gray cardboard.

Price: USD3/PC

**4.E74C**

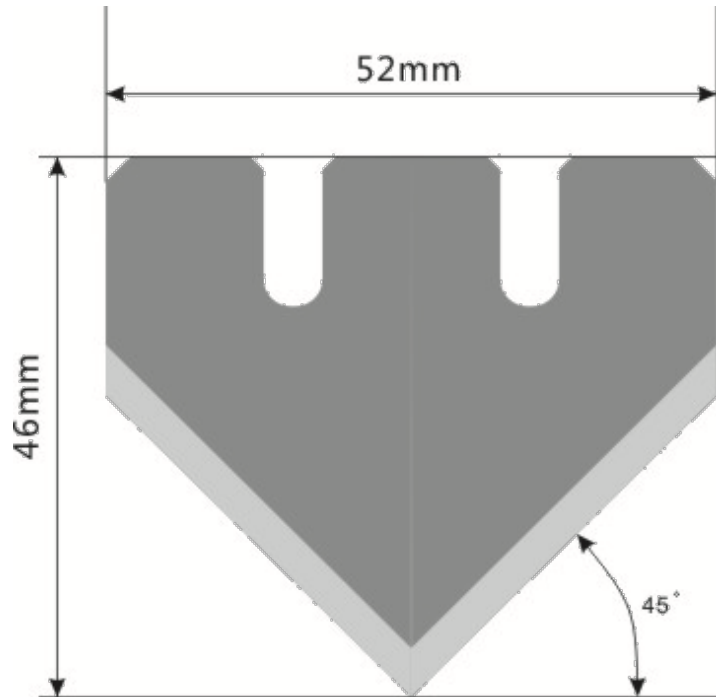

Name: E74C

Raw Material: Carbon Steel

Blade Thickness: 1mm

Cutting Thickness: 20mm

Applicable Tool: V-Cut

Applicable Industry: Sign & Graphics、Packaging

Applicable Material: Honeycomb Board、Vertical Corrugated、Gray cardboard.

Price: USD25/PC

**5.E75C**

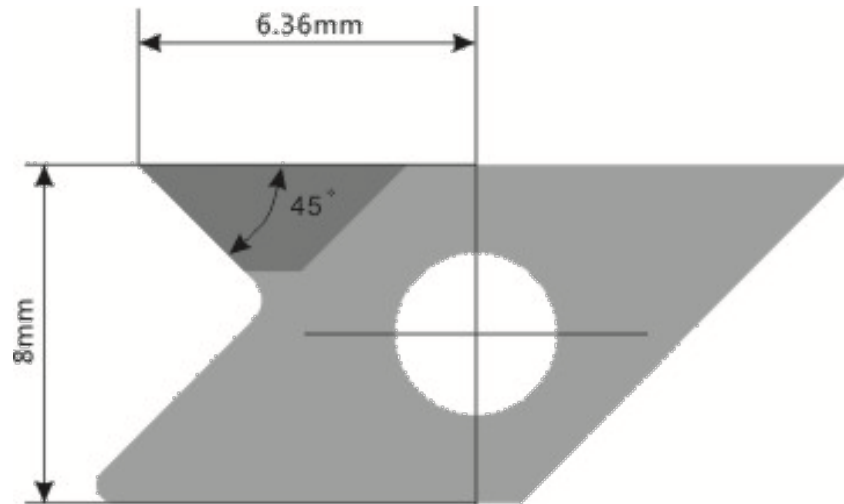

Name: E75C

Raw Material: Carbon Steel

Blade Thickness: 1mm

Cutting Thickness: 4mm

Applicable Tool: V-Cut

Applicable Industry: Sign & Graphics、Packaging

Applicable Material: KT BOARD、Gray cardboard.

**6.E77C**

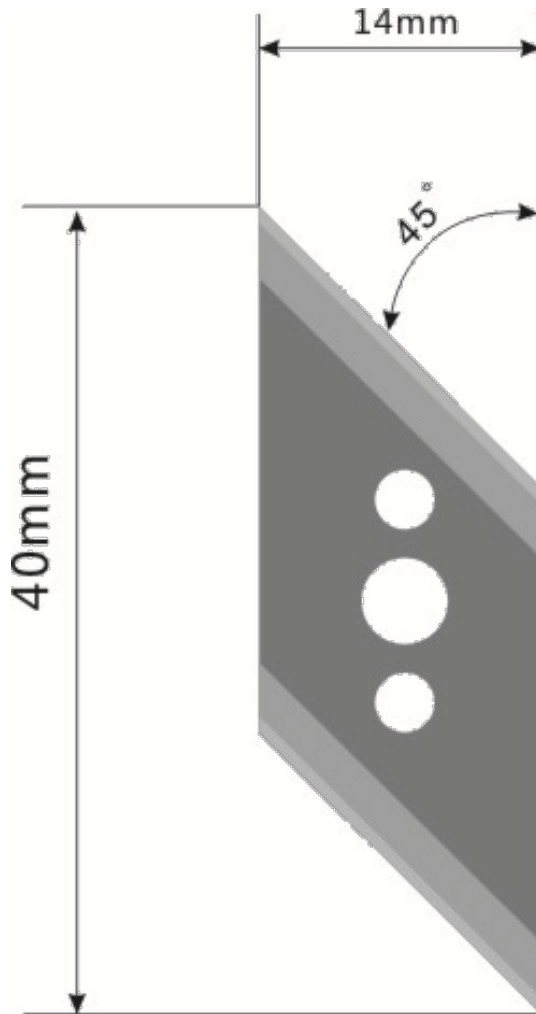

Name: E77C

Raw Material: Carbon Steel

Blade Thickness: 1mm

Cutting Thickness: 9mm

Applicable Tool: V-Cut

Applicable Industry: Sign & Graphics、Packaging

Applicable Material: KT BOARD、Gray cardboard.

## 七. Notch Tool 1、E81

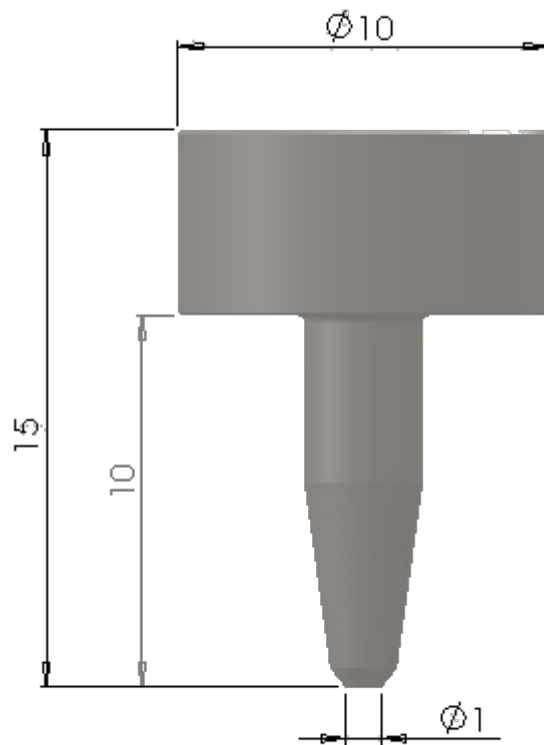

Name: E81

Raw Material: Tungsten Steel

Notch Diameter: 1mm

Cutting Thickness: 5mm

Applicable Tool: Notch Tool

Applicable Industry: Garment、Leather

Applicable Material: PU COMPOSITE SPONG、PU、PVC

Price: USD25/PC

## 2、E82

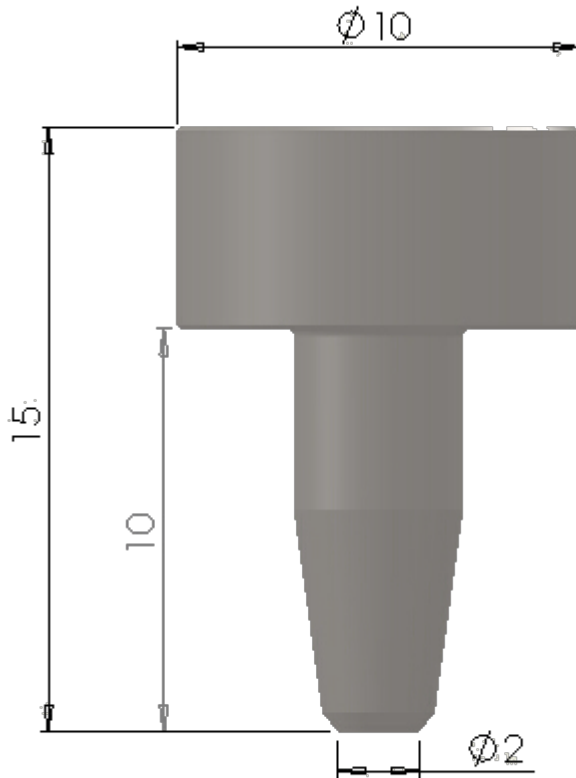

Name: E82

Raw Material: Tungsten Steel

Notch Diameter: 2mm

Cutting Thickness: 5mm

Applicable Tool: Notch Tool

Applicable Industry: Garment、Leather

Applicable Material: PU COMPOSITE SPONG、PU、PVC

Price: USD25/PC

### 3. E83

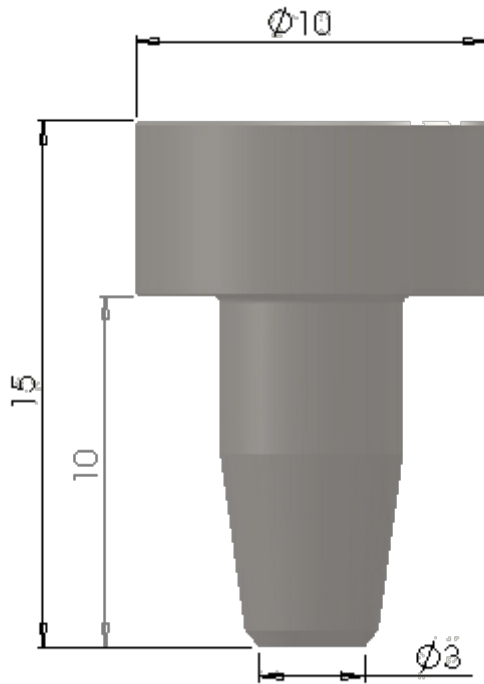

Name: E83

Raw Material: Tungsten Steel

Notch Diameter: 3mm

Cutting Thickness: 5mm

Applicable Tool: Notch Tool

Applicable Industry: Garment、Leather

Applicable Material: PU COMPOSITE SPONG、PU、PVC

Price: USD25/PC

#### 4. E84

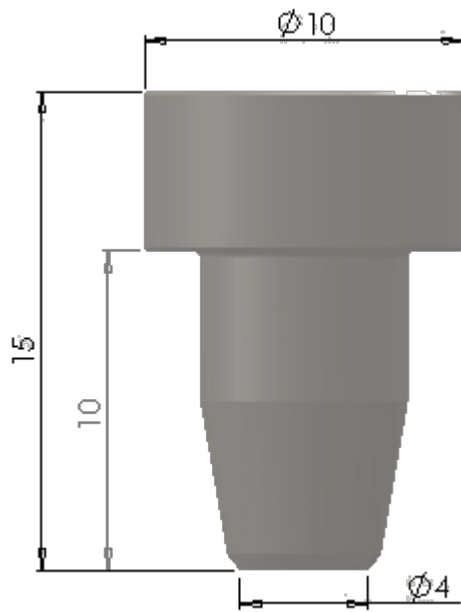

Name: E84

Raw Material: Tungsten Steel

Notch Diameter: 4mm

Cutting Thickness: 5mm

Applicable Tool: Notch Tool

Applicable Industry: Garment、Leather

Applicable Material: PU COMPOSITE SPONG、PU、PVC

Price: USD25/PC

**5. E84-4**

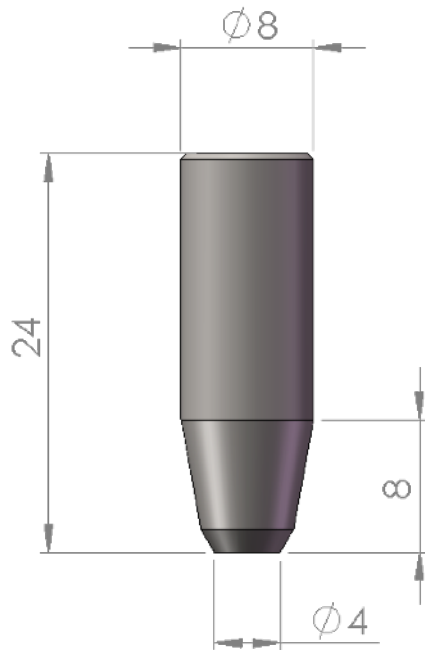

Name: E84-4

Raw Material: High speed steel

Notch Diameter: 4mm

Cutting Thickness: 8mm

Applicable Tool: BMK CUTTING HEAD

Applicable Industry: Garment、Leather、Footwear

Applicable Material: PU COMPOSITE SPONG、PU、PVC、Plush composite sponge

Price: USD25/PC

## 6. EP1

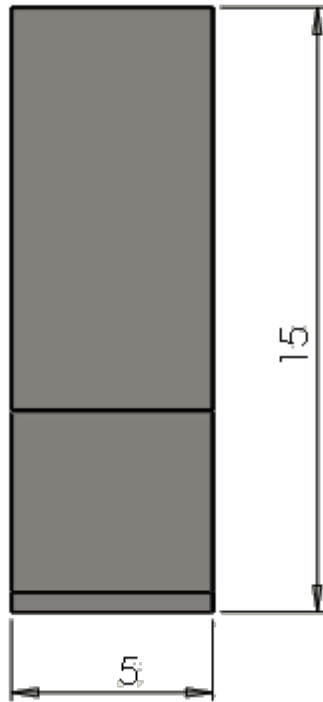

Name: EP1

Raw Material: Tungsten Steel

Notch Width: 5mm

Cutting Thickness: 5mm

Applicable Tool: Notch Tool

Applicable Industry: Garment、Leather

Applicable Material: PU COMPOSITE SPONG、PU、PVC、

Price: USD10/PC

## 7. EP2

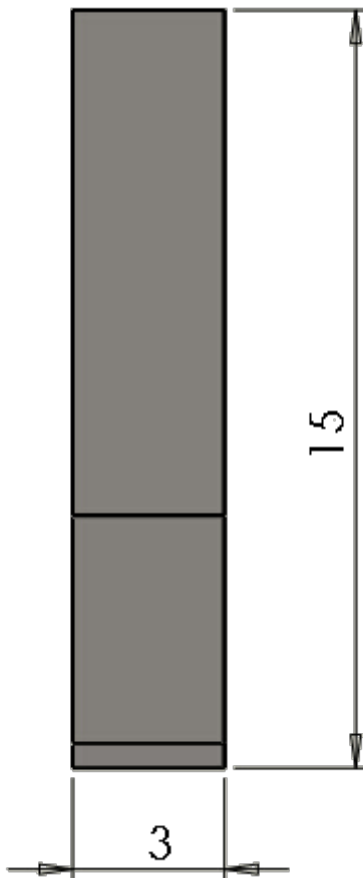

Name: EP2

Raw Material: Tungsten Steel

Notch Width: 3mm

Cutting Thickness: 5mm

Applicable Tool: Notch Tool

Applicable Industry: Garment、Leather

Applicable Material: PU COMPOSITE SPONG、PU、PVC、

Price: USD10/PC

## 8. EPV

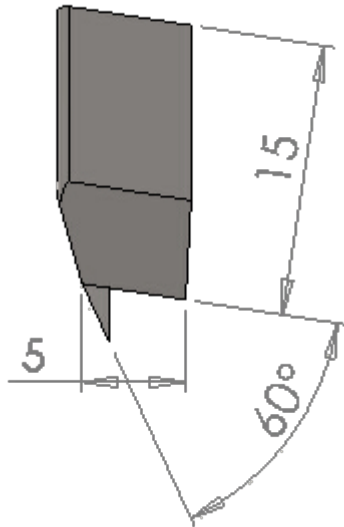

Name: EPV

Raw Material: Tungsten Steel

Notch Width: 5mm

Angle: 60Degree

Cutting Thickness: 5mm

Applicable Tool: Notch Tool

Applicable Industry: Garment、Leather

Applicable Material: PU COMPOSITE SPONG、PU、PVC、

Price: USD25/PC

## 9. EPV2

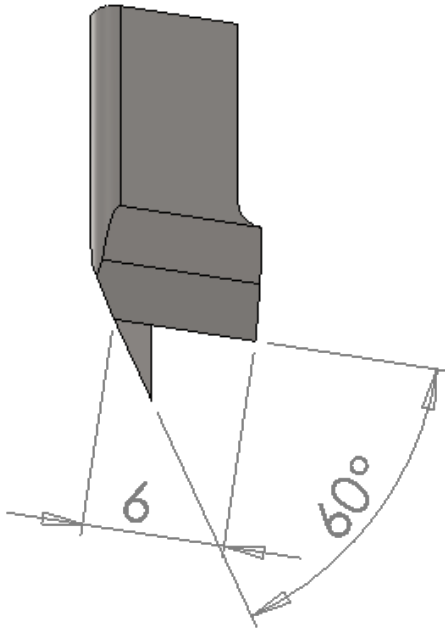

Name: EPV2

Raw Material: Tungsten Steel

Notch Width: 6mm

Angle: 60Degree

Cutting Thickness: 5mm

Applicable Tool: Notch Tool

Applicable Industry: Garment、Leather

Applicable Material: PU COMPOSITE SPONG、PU、PVC、

Price: USD25/PC

## 10. EPV3

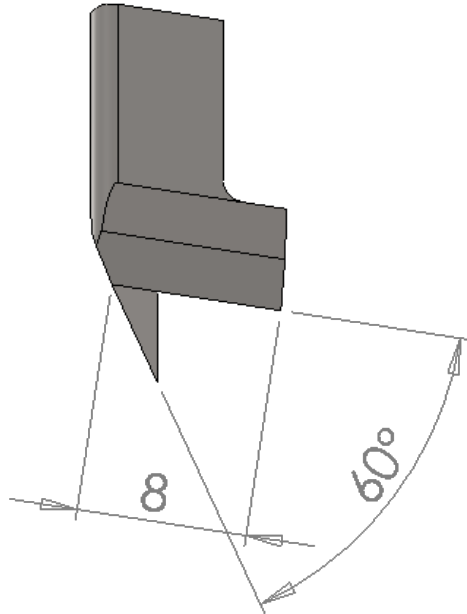

Name: EPV3

Raw Material: Tungsten Steel

Notch Width: 8mm

Angle: 60Degree

Cutting Thickness: 5mm

Applicable Tool: Notch Tool

Applicable Industry: Garment、Leather

Applicable Material: PU COMPOSITE SPONG、PU、PVC、

Price: USD25/PC