



Under Feed Stoker

Combustion System

HURST *The Solid Fuel People*

- (1) Cast Alloy Under Fire Stoker
- (2) Fuel Metering Bin
- (3) Optional (gas/oil) Burner
- (4) Fire Door/Clean-Out
- (5) Fly-Ash Collection System
- (6) Rotary Air Lock Fuel Feeder
- (7) 3-pass Wet Back Boiler
- (8) Packaged Combustion Chamber
- (9) Rotary Air Lock/Fly-Ash Dump
- (10) Tube Cleaning Access
- (11) Induce Draft Fan
- (12) Under Fire Air fan

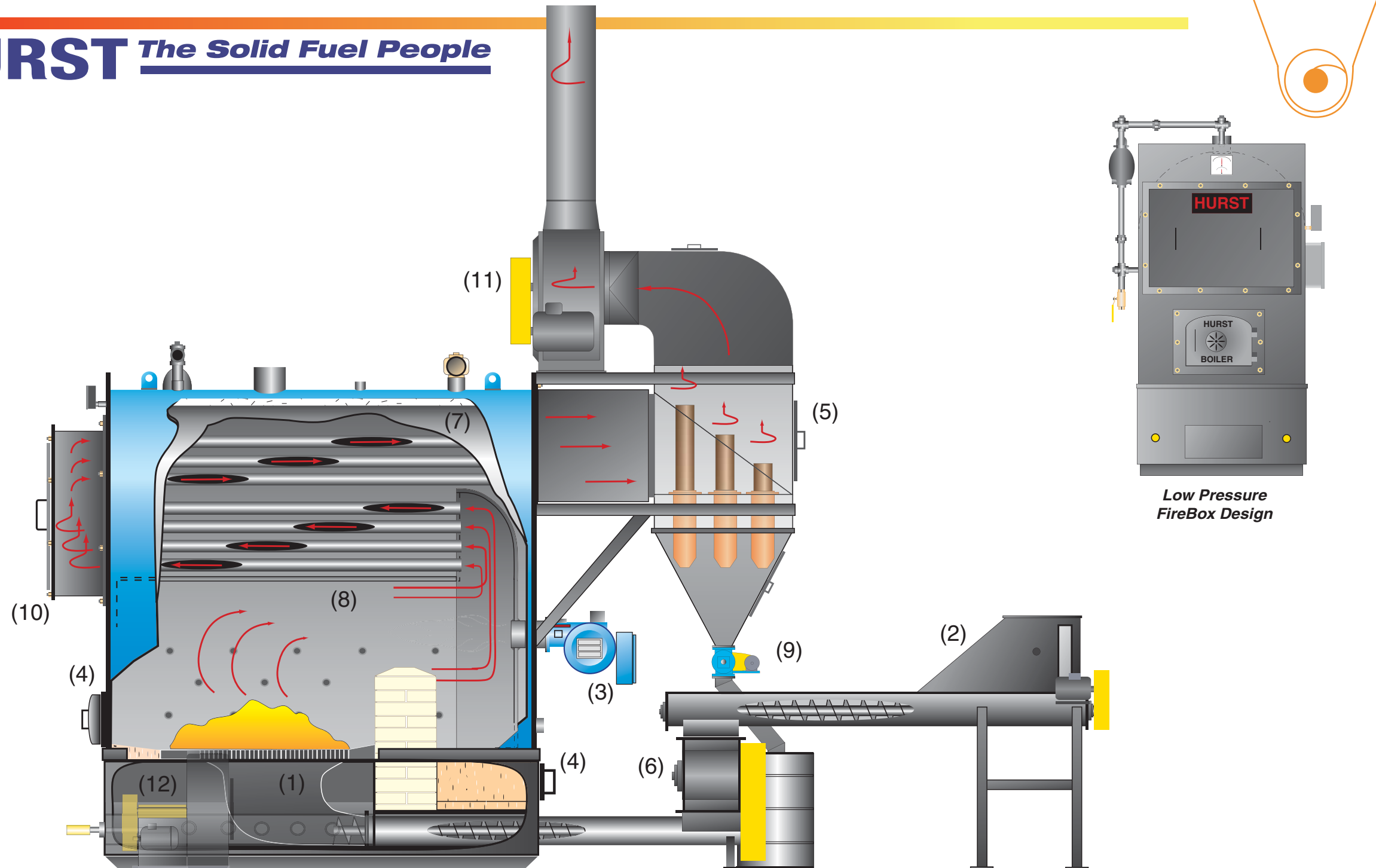

HURST BOILER & WELDING CO., INC.
 P.O. Drawer 530
 21971 Highway 319 N.
 Coolidge, Georgia 31738
 Toll Free: 1-877-994-8778
 Tel: (229) 346-3545
 Fax: (229) 346-3874
 Email: info@hurstboiler.com

The FireBox LPD UF design is suitable for applications to produce low pressure steam or hot water in ranges from 3,450 – 20,700 lbs/hr (3.4 mmBTU – 20 mmBTU) output at 15 PSI steam or 30 PSI hot water. This system is designed by HBC to combine the best technologies from the "old school" of biomass combustion and the latest advanced combustion control technologies. HBC's new hand fired systems are particularly suited for operations with extremely low labor cost environments. This combination enables these systems to provide a flexible and reliable operation utilizing a wide range of biomass waste with moisture contents ranging from 8 – 50% and requiring minimal fuel preparation. Ash removal is a manual operation. The boiler vessel is a two pass hybrid design incorporating a water tubed boiler-type water membrane and a two-pass fire tube scotch marine vessel. The boiler vessel is a three-pass fire tube firebox design that inherently provides an extended water membrane in the furnace area greatly reducing the amount of refractory required.

CAT# W-03

FIREBOX LPD UF

MULTI FUEL

Under Fire Feed System

Modular Packaged