

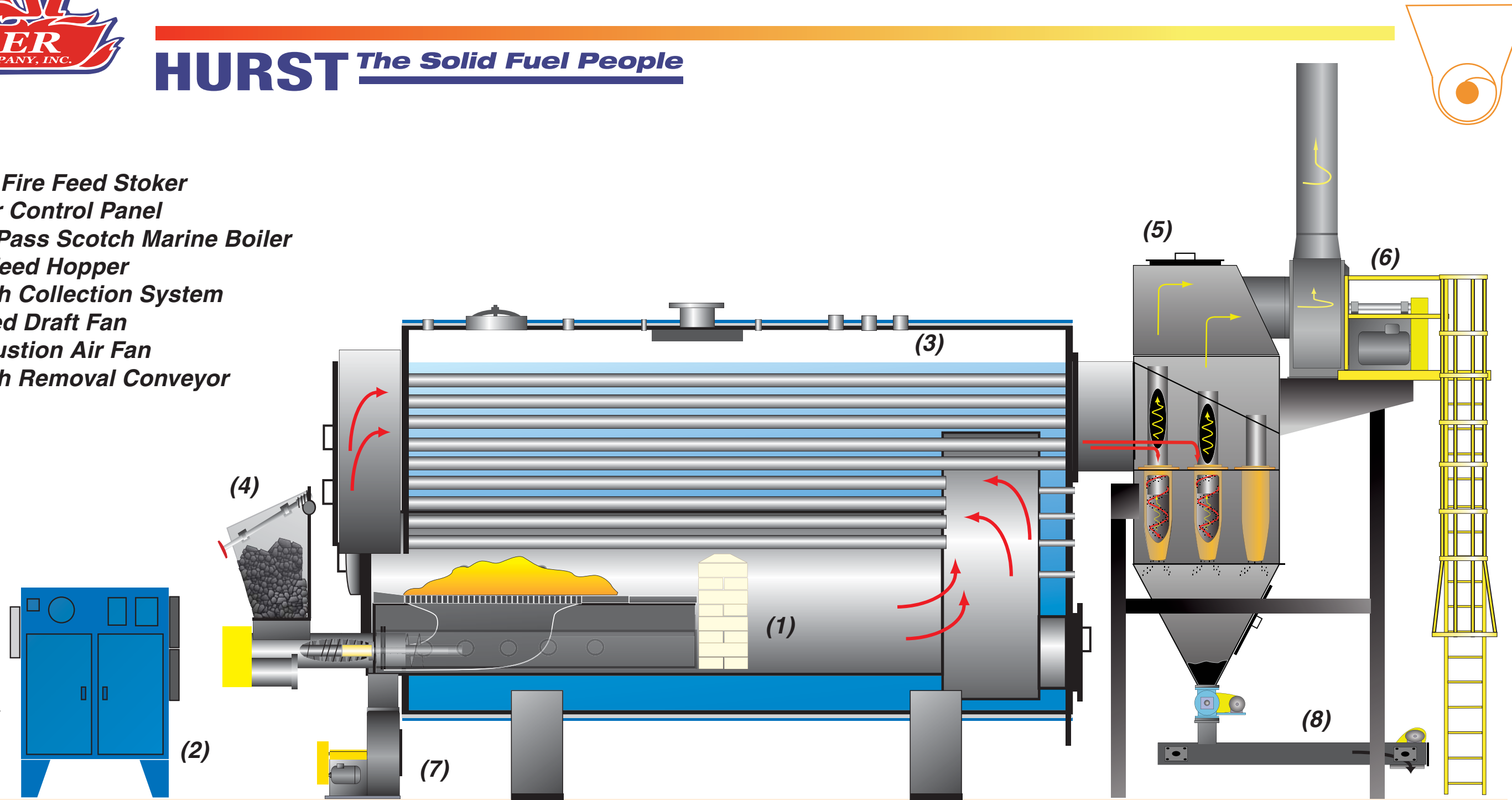

HURST *The Solid Fuel People*

Under Feed Stoker
Combustion System

- (1) Under Fire Feed Stoker
- (2) Master Control Panel
- (3) Three Pass Scotch Marine Boiler
- (4) Coal Feed Hopper
- (5) Fly Ash Collection System
- (6) Induced Draft Fan
- (7) Combustion Air Fan
- (8) Fly Ash Removal Conveyor



HURST BOILER & WELDING CO., INC.
P. O. Drawer 530
21971 Highway 319 N.
Coolidge, Georgia 31738
Toll Free: 1-877-994-8778
Tel: (229) 346-3545
Fax: (229) 346-3874
Email: info@hurstboiler.com

The CoalMiser HPD UF design is suitable for applications to produce high pressure steam or hot water in ranges from 2,000 – 8,000 lbs/hr (2 mmBTU – 7.7 mmBTU) output from 150 up to 400 PSI. This system is designed by HBC to combine the best technologies from the "old school" of coal combustion and the latest advanced combustion control technologies. The stationary underfeed stoker system provides a very low turn-down rate making it particularly suitable for heating applications in greenhouses, factories, schools and office buildings. This combination enables these systems to provide the most reliable operation utilizing a consistent single "grade" of low sulfur bituminous coal. Ash removal is available in manual and automatic configurations. The boiler vessel is a three-pass fire tube design incorporating a wet back turnaround that eliminates the need for rear door refractory.

CAT# C-02

COALMISER HPD UF

COAL FIRED

Modular Packaged