

IS DRILLING TEMPLATE AND INSTALLATION INSTRUCTIONS

1. This handle set is designed for inswinging doors only.
2. Close your door, and place the template on the inside door surface. Align the dotted line of the template with the edge of the door jamb. Ensure that you are aligning it to the door jamb, and not the edge of the door. (Fig 2)
3. Mark all hole locations with a centre punch. Drill three 1/4" holes straight through the door. Drill two 3/16" holes 1" deep on the door jamb. (Fig 3)
4. Fasten the handle set and the strike in place.

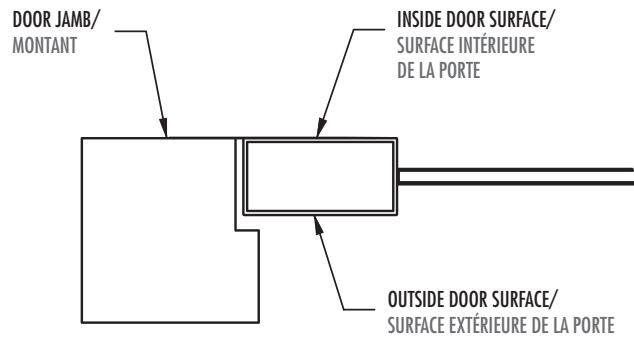

(Fig.1)

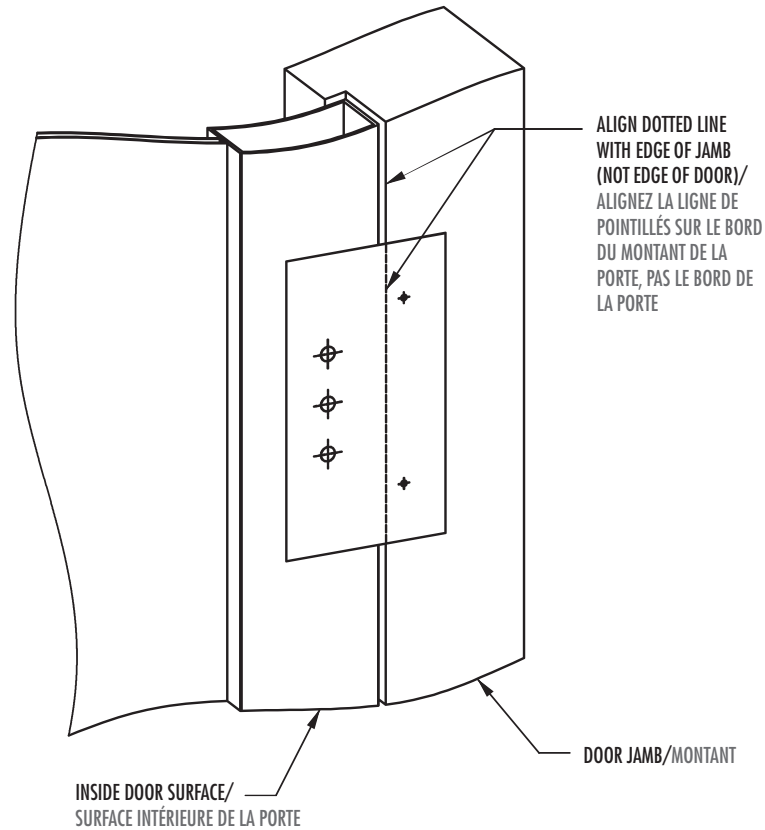

(Fig.2)

IS GABARIT DE PERÇAGE ET INSTRUCTIONS D'INSTALLATION

1. Cet ensemble de poignée est conçu pour porte ouvrant vers l'intérieure seulement.
2. Fermez la porte, placez le gabarit sur la surface intérieure de la porte. Aligned la ligne de pointillés sur le bord du montant de la porte, pas le bord de la porte. (Fig 2)
3. Marquer la position des trous avec un poinçon. Percez trois trous de 1/4 po au travers la porte. Percez deux trous de 3/16 po et 1 po de profondeur sur le montant. (Fig 3)
4. Fixer les poignées et la gâche en place.

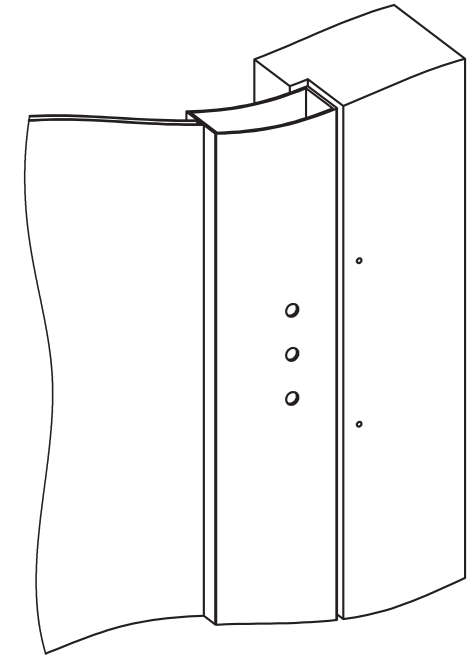

(Fig.3)

DRILLING TEMPLATE

Print out this sheet at 1:1 scale

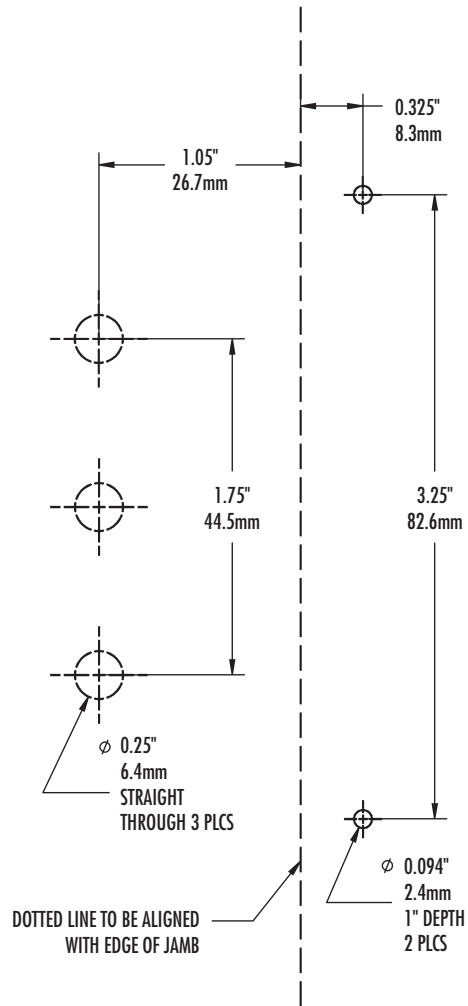

GABARIT DE PERÇAGE

Imprimez cette page à l'échelle 1:1

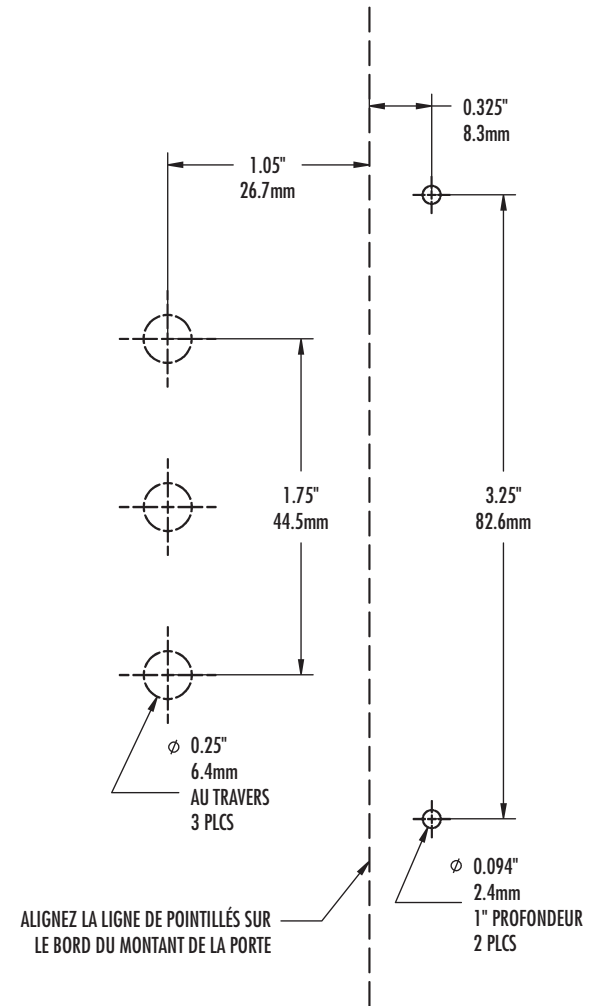

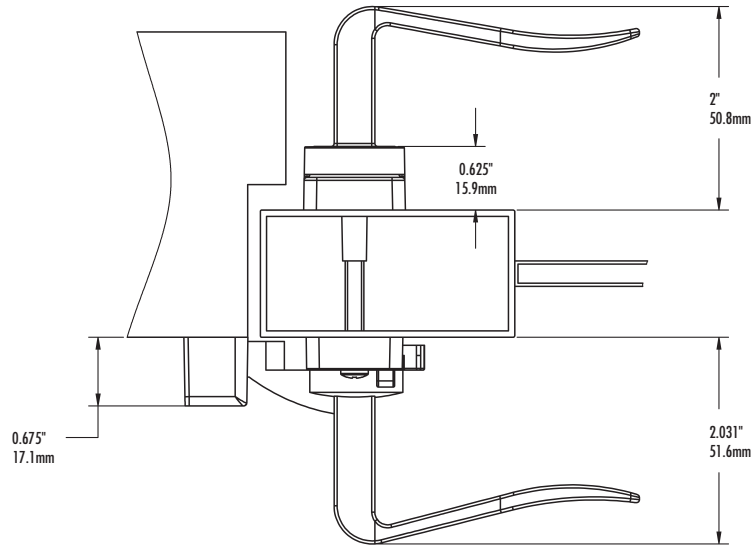
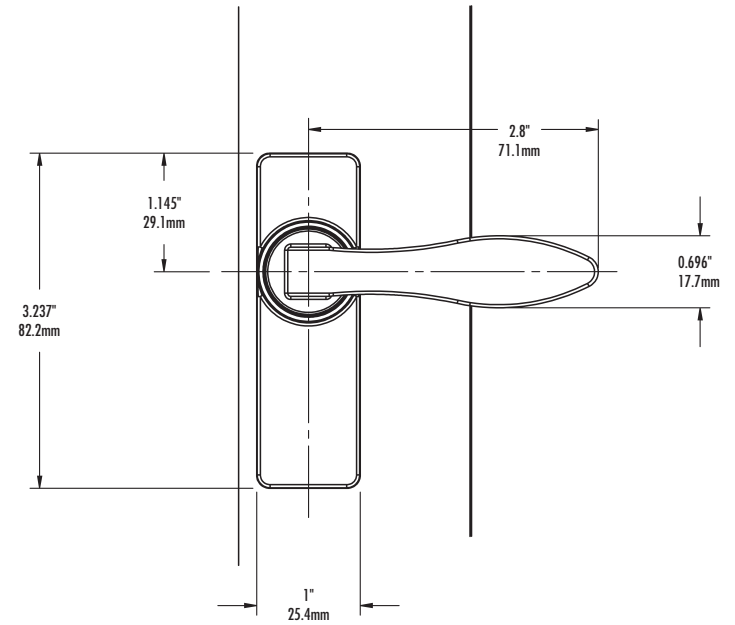
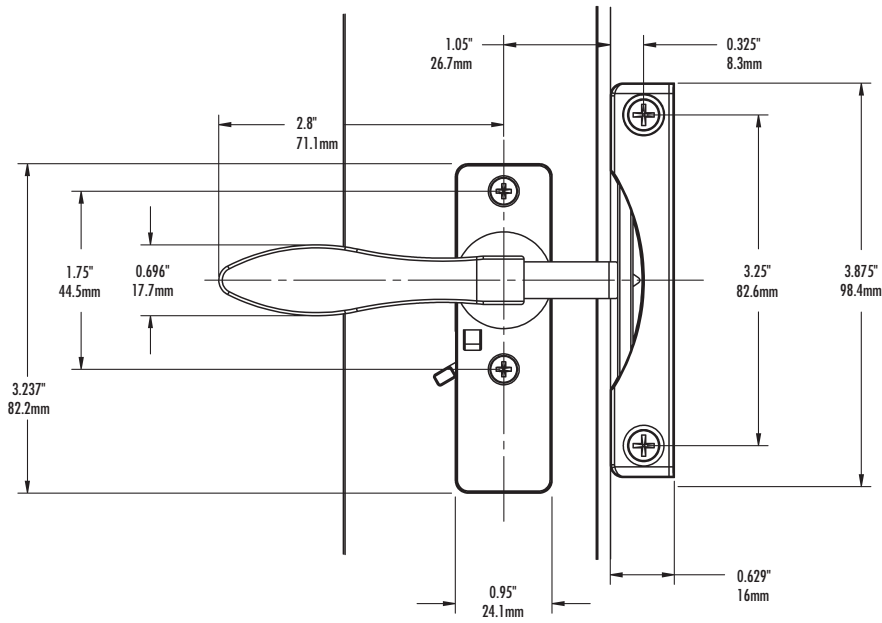

For detailed instructions and how-to videos, please visit our website www.idealinc.com

Pour des instructions plus détaillées et des vidéos, veuillez visiter notre site web www.idealinc.com

IDEAL SECURITY INC.
LASALLE, QC • PRESCOTT, ON
www.idealinc.com

info@idealinc.com
help.idealinc.com