



**MANUAL DE MONTAGEM
ASSEMBLY INSTRUCTIONS
INSTRUCCIONES DE MONTAJE**

**COD BR: BR 376-143
COD US: 111AMC143**

Sumário Summary Resumen

Introdução Introduction Introducción	3
Antes de começar Before starting Antes de comenzar	4
Evite acidentes Avoid accidents Evitar accidentes	4
Dimensões e ferramentas Dimensions and tools Dimensiones y herramientas	5
Identificação das peças Identifying parts Identificación de las piezas	6
Acessórios incluídos na caixa Hardware included in box Accesorios incluidos en la caja	7
Montagem do móvel Furniture assembly Montaje del mueble	8

Introdução Introduction Introducción

Leia atentamente este manual e siga os passos indicados para uma perfeita montagem.
Read this manual and follow the steps for the perfect fit.
Lea este manual y siga los pasos para el ajuste perfecto.

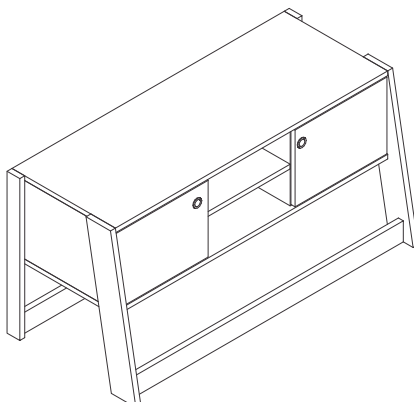

Antes de começar Before starting Antes de comenzar

Antes de começar a montagem prepare o ambiente, deixando-o completamente limpo e com bom espaço para iniciar o trabalho.

Prepare the room before starting the assembly, leaving it completely clean and the area in good condition to start the work.

Antes de comenzar el montaje preparar el ambiente, dejándolo completamente limpio y con bueno espacio para comenzar el trabajo.

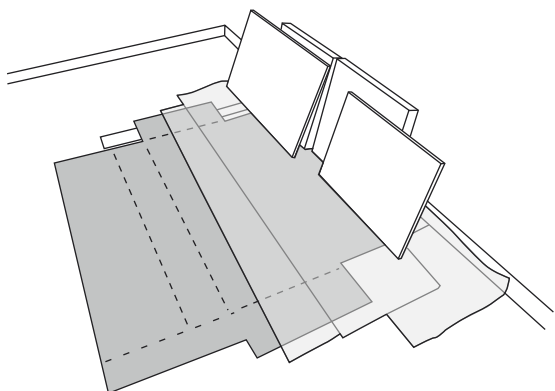

Utilize o papelão da própria embalagem para separar e apoiar as peças retiradas das caixas.

Use the cardboard of the packaging to separate and support the parts removed from the boxes.

Utilice el cartón de la embalaje para separar y apoyar las piezas desmontadas de las cajas.



Forre a área de montagem com um cobertor ou tapete. Assim, você evita avarias nas peças durante o processo de montagem.

Cover the assembly area with a blanket or carpet to avoid damaging the parts during the assembly process.

Cubrir la zona de ensamble con una manta o alfombra. De este modo, se evitan daños en las piezas durante el proceso de montaje.

Evite acidentes Avoid accidents Prevenir accidentes

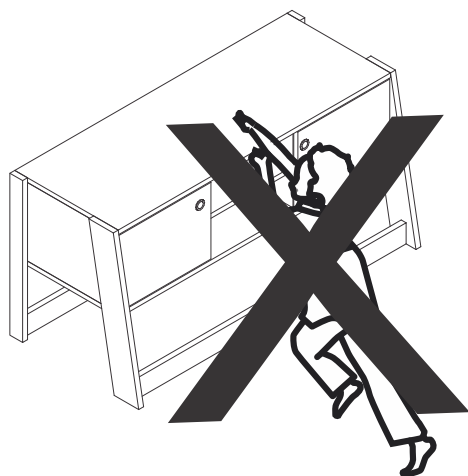

Não escale ou se apoie no móvel.

Do not climb or lean on the furniture.

No se suba ni se apoye en el mueble.

Dimensões e ferramentas
Dimensions and tools
Dimensiones y herramientas

Dimensões:

L: 1036 A: 515 P: 473 mm

Dimensions:

W: 40.78 H: 20.27 D: 18.62 inches

Dimensiones:

L: 1036 A: 515 P: 473 mm

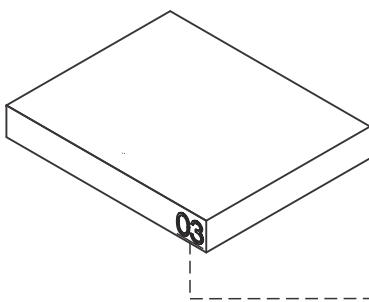
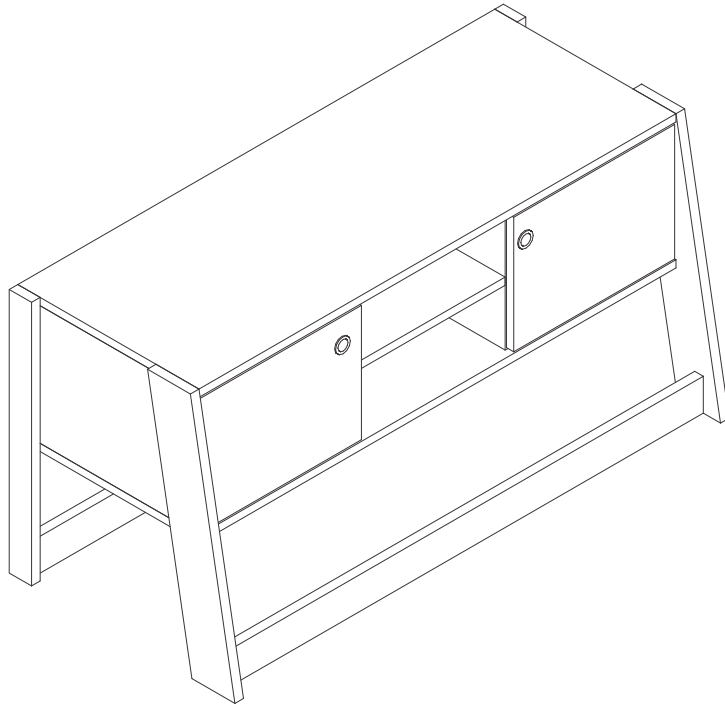

UTILIZE ALCOOL PARA REMOVER O NUMERO DAS PEÇAS
USE ALCOHOL TO REMOVE PART NUMBERS
UTILICE ALCOHOL PARA ELIMINAR EL NUMERO DE LAS PIEZAS

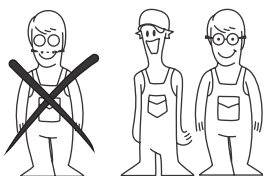

Para facilitar a montagem, utilize uma parafusadeira elétrica.
To improve assembly, use an electronic screwdriver.
Para facilitar el armado, utilice un destornillador eléctrico.

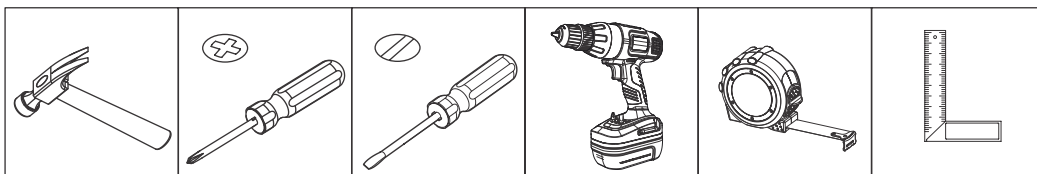

COD BR: BR 376-143
 COD US: 111AMC143

PEÇA	DESCRIÇÃO	QUANT.	PART	DESCRIPTION	QTY	PIEZA	DESCRIPCIÓN	CANTIDAD
001	BASE	1	001	BASE	1	001	BASE	1
002	TAMPO	1	002	TOP	1	002	TAPA	1
003	LATERAL DIREITA	1	003	RIGHT SIDE	1	003	LATERAL DERECHA	1
004	LATERAL ESQUERDA	1	004	LEFT SIDE	1	004	LATERAL IZQUIERDA	1
005	PRATELEIRA	3	005	SHELF	3	005	REPISA	3
006	DIVISÓRIA	2	006	PARTITION	2	006	PARTICIÓN	2
007	PORTA	2	007	DOOR	2	007	PUERTA	2
008	COSTA	2	008	BACK	2	008	REVÉS	2
009	PÉ FRONTAL	2	009	FRONTAL FEET	2	009	PIE FRONTAL	2
010	PÉ POSTERIOR	2	010	REAR FEET	2	010	PIE TRASERO	2
011	TRAVESSA	2	011	DETAIL	2	011	DETALLE	2

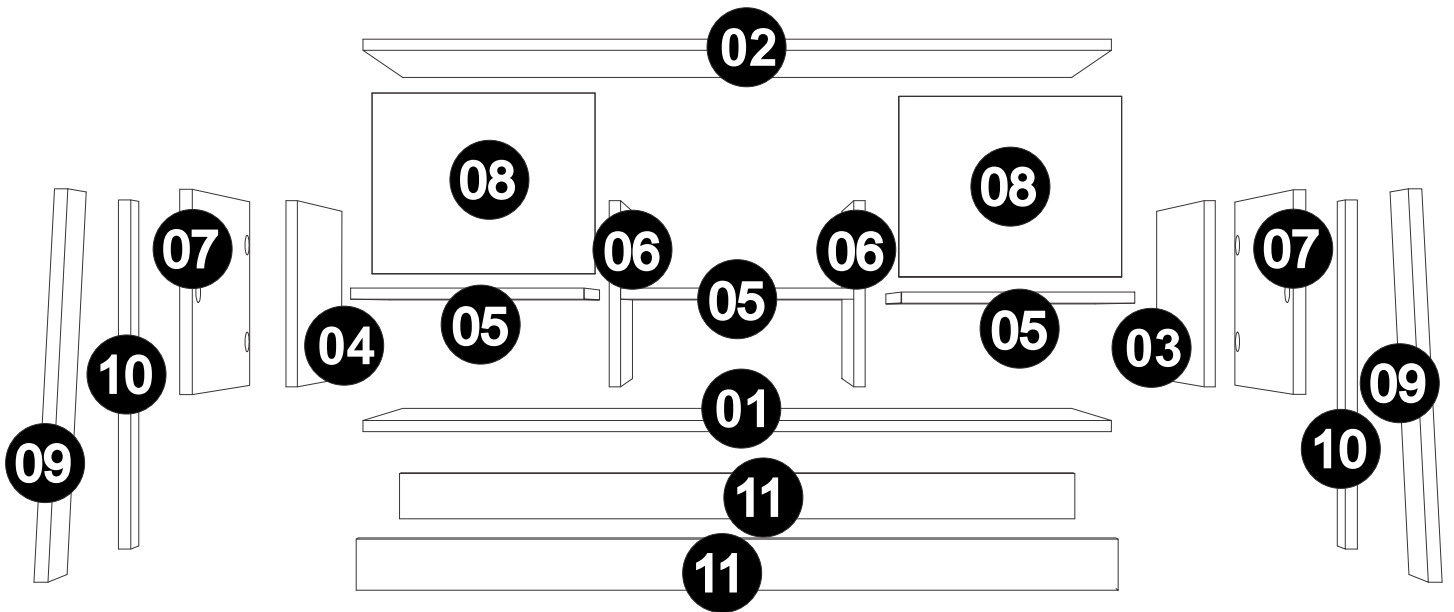



EF 000106 x 16



PUXADOR x 2
HANDLE x 2
MANIJA x 2



EF 000168 X 28



EF 000033x 28



EF 000132 x 8



EF 000247 X 4

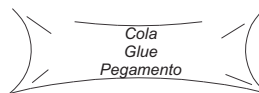

EF 000008 X 2



GIZ x 01
CHALK x 01
TIZA x 01

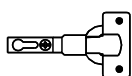

EF 000044 X 4



EF 000404 X 8



EF 000349 X 4



EF 000113 X 4



EF 000241 X 8

A = 3 KG - 6.61LB

B = 5 KG - 11LB

C = 15 KG - 331LB

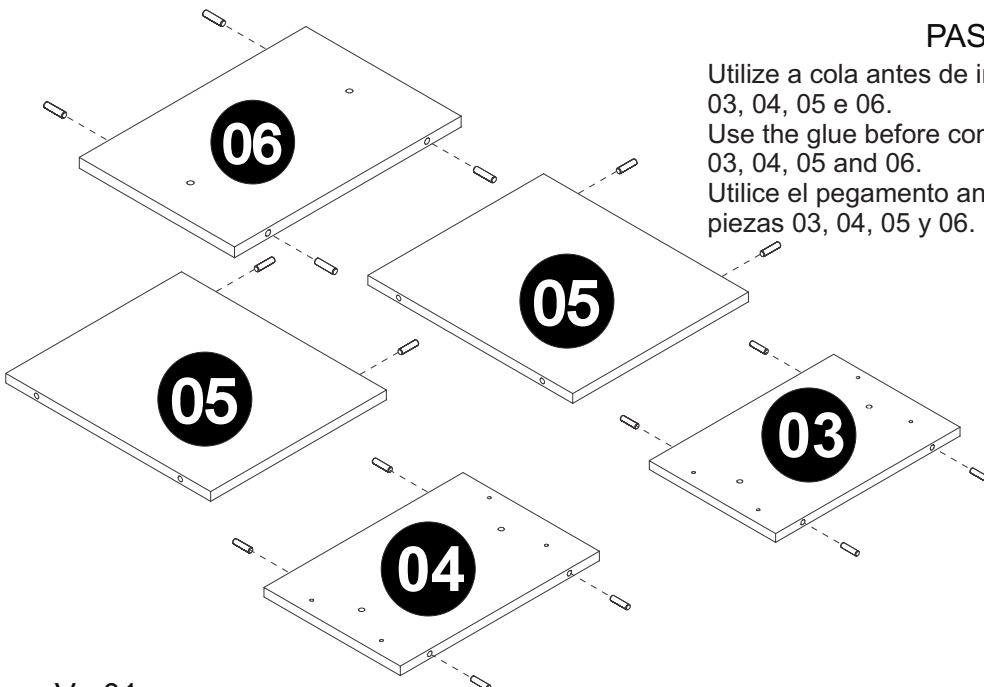
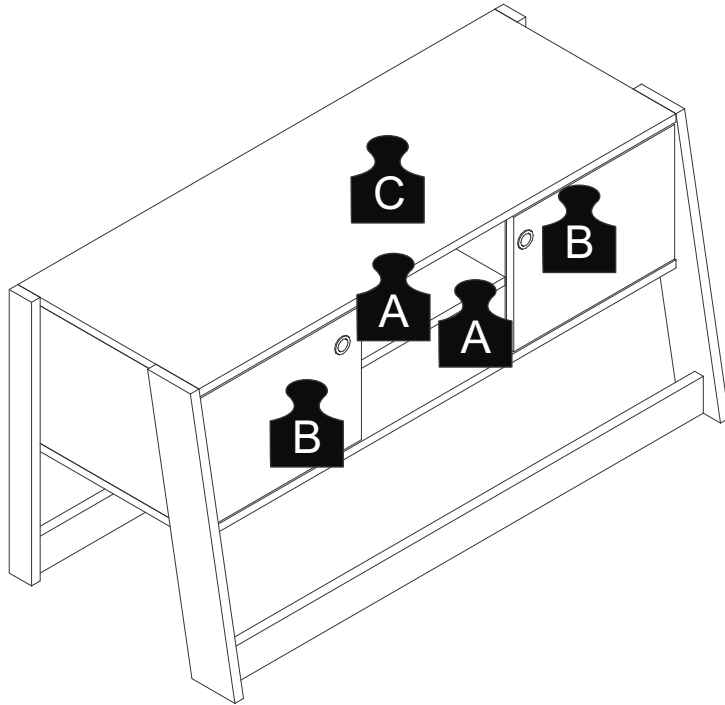

PASSO 1 / STEP 1 / PASO 1

Utilize a cola antes de inserir a ferragem EF 000033 nas peças 03, 04, 05 e 06.

Use the glue before connecting hardware EF 000033 into pieces 03, 04, 05 and 06.

Utilice el pegamento antes de añadir el herraje EF000033 en las piezas 03, 04, 05 y 06.

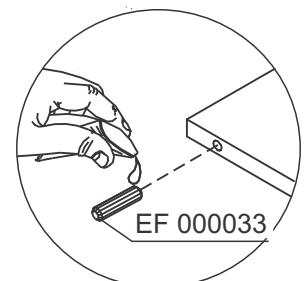

PASSO 2 / STEP 2 / PASO 2

Fixe a ferragem EF 000349 nas peças 03 e 04 usando a ferragem EF 000106.
Fix hardware EF 000349 at pieces 03 and 04 using hardware EF 000106.
Fije el herraje EF 000349 en las piezas 03 y 04 utilizando el herraje EF 000106.

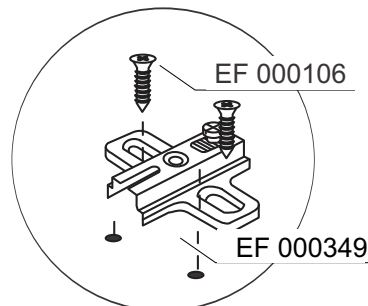
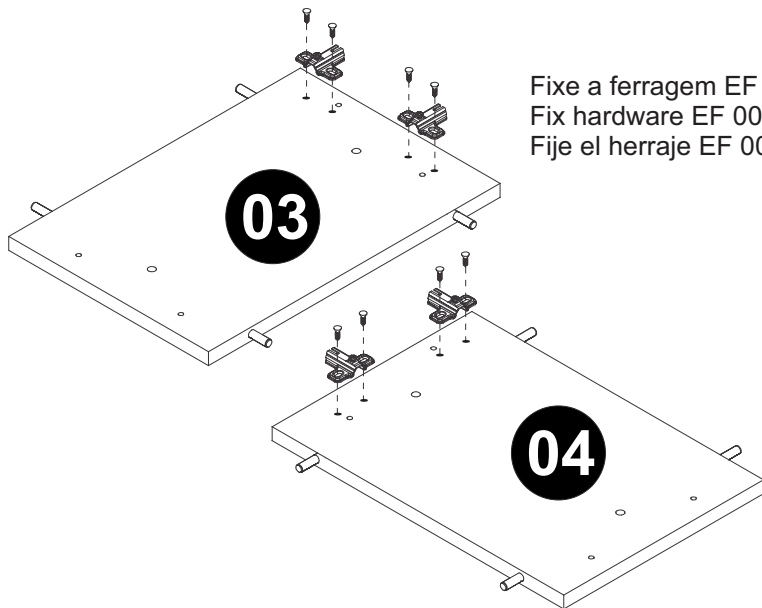

PASSO 3 / STEP 3 / PASO 3

Fixe a ferragem EF 000044 nas peças 07 utilizando a ferragem EF 000106. Insira o puxador.
Fix hardware EF 000044 into pieces 07 using hardware EF 000106. Insert the handle.
Fije el herraje EF 000044 en las piezas 07 utilizando el herraje EF 000106. Añade la manija.

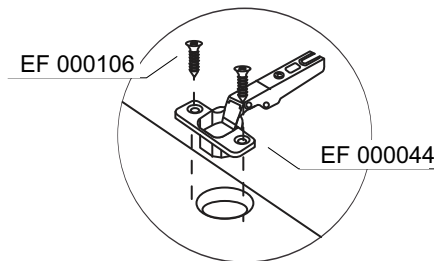
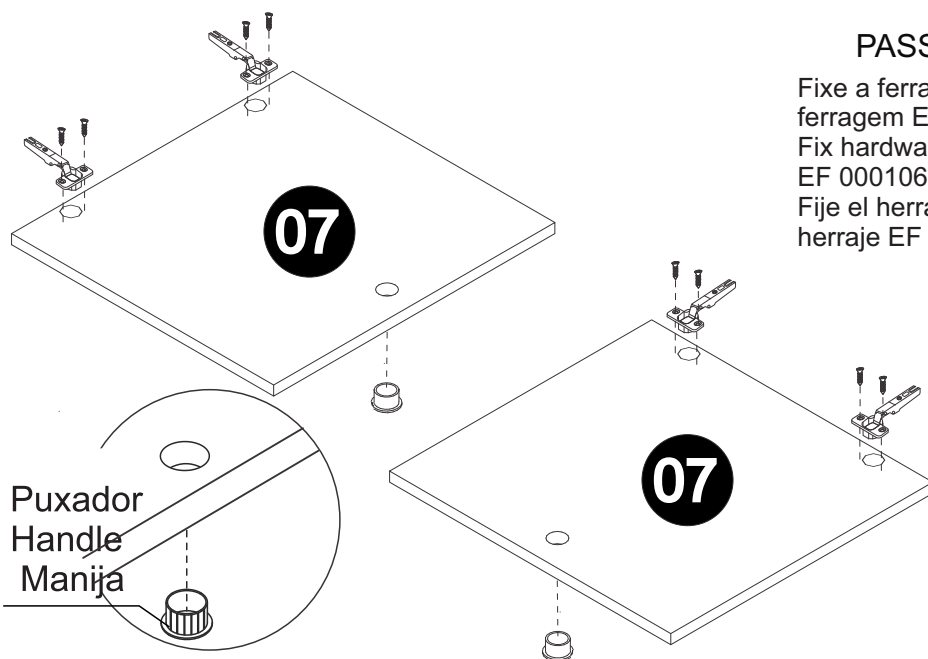

PASSO 4 / STEP 4 / PASO 4

Utilize a cola antes de conectar as peças 03, 04, 05 e 06.
Use the glue before connecting pieces 03, 04, 05 and 06.
Utilice el pegamento antes de juntar las piezas 03, 04, 05 y 06.

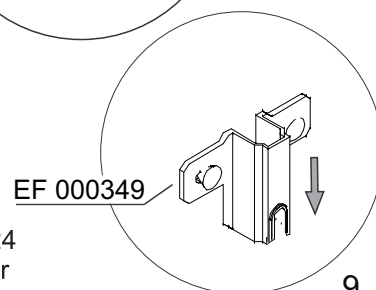
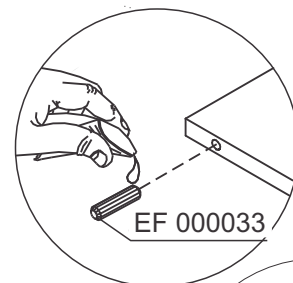
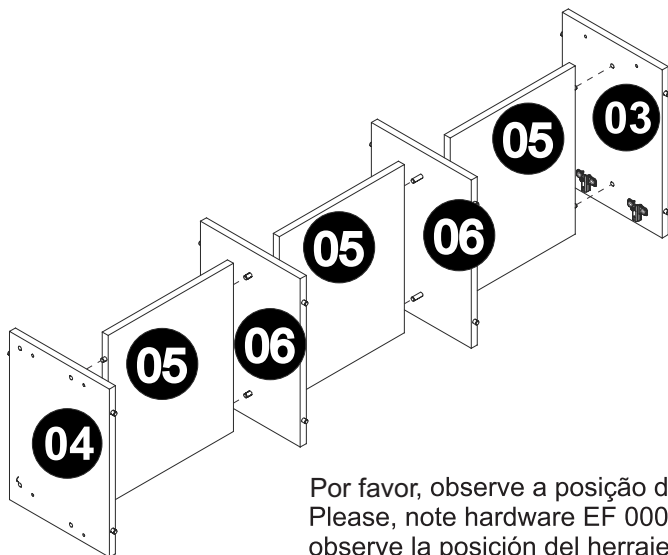

Por favor, observe a posição da ferragem EF 000024
Please, note hardware EF 000024 position. Por favor
observe la posición del herraje EF000024.

PASSO 5 / STEP 5 / PASO 5

Use a cola antes de fixar a peça 02 à parte montada no passo anterior. Use a ferragem EF 000132 para fixar a peça 01.

Use the glue before connecting piece 02 to the part assembled in the previous step. Use hardware EF 000132 to fix piece 01.

Utilice el pegamento antes de juntar la pieza 02 a la parte armada en el paso anterior. Utilice el herraje EF 000132 para fijar la pieza 01.

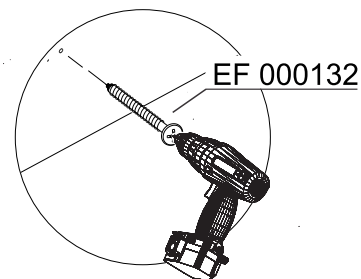
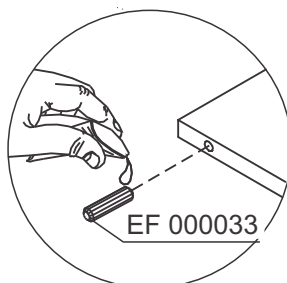
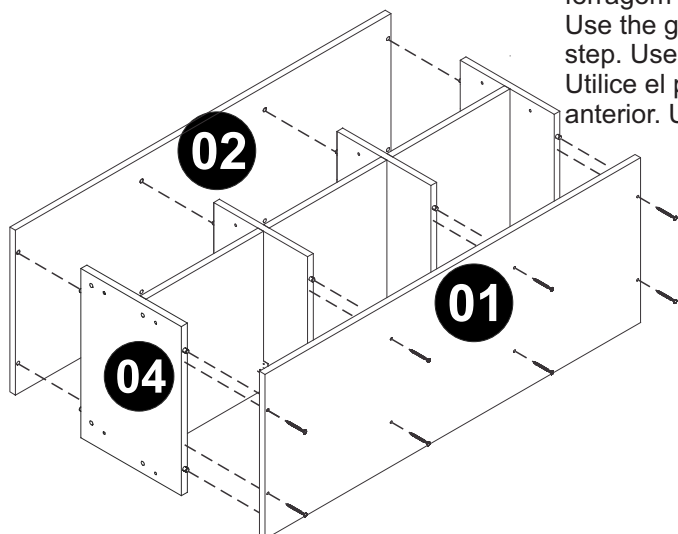

PASSO 6 / STEP 6 / PASO 6

Insira a ferragem EF 000241 nas peças 11.

Insert hardware EF 000241 into pieces 11.

Añade el herraje EF 000241 en las piezas 11.

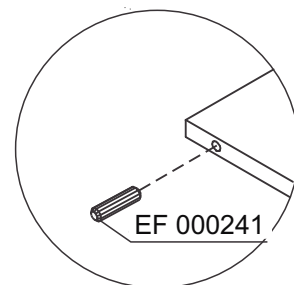
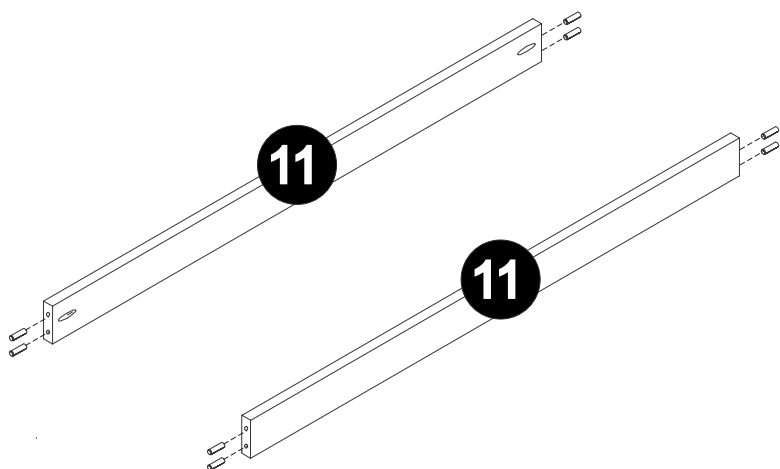

PASSO 7 / STEP 7 / PASO 7

Use a cola antes de conectar as peças 09 e 10 ao móvel. Fixe os pés ao móvel usando a ferragem EF 000404 e fixe as peças 09, 10 e 11 usando a ferragem EF 000113.

Use the glue before connecting pieces 09 and 10 to the furniture. Fix the feet at the furniture using hardware EF 000404 and use hardware EF 000113 to fix pieces 09, 10 and 11.

Utilice el pegamento antes de juntar las piezas 09 y 10 al mueble. Fije los pies en el mueble utilizando el herraje EF 000404. y utilice el herraje EF 000113 para fijar las piezas 09, 10 y 11.

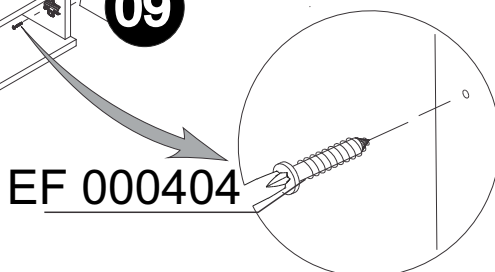
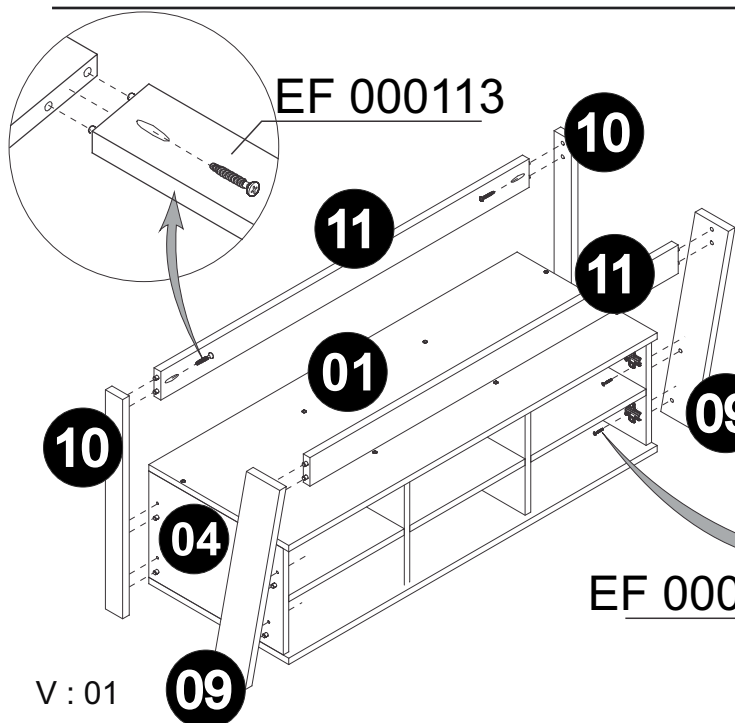

PASSO 8 / STEP 8/ PASO 8

Fixe as peças 08 usando a ferragem EF 000168.
Fix pieces 08 using hardware EF 000168.
Fije las piezas 08 utilizando el herraje EF 000168.

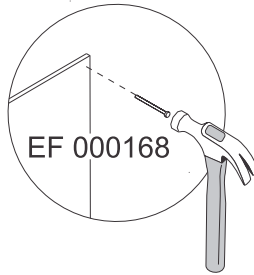
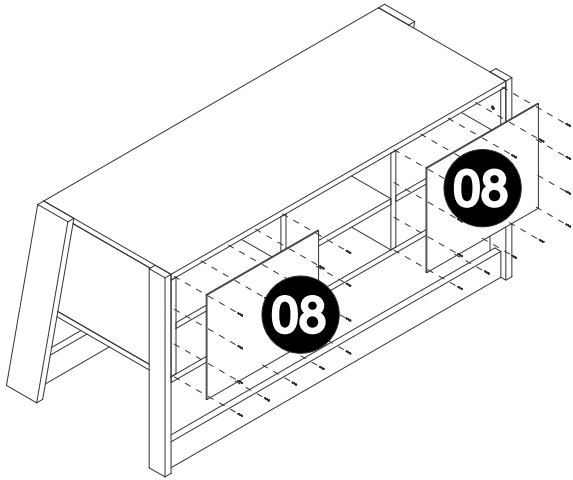

PASSO 9 / STEP 9 / PASO 9

Utilize o giz para dar o acabamento final ao produto.
Use the chalk to give the final finish on the product.
Utilize la tiza para dar el acabado final al producto.

