



B6 LED License Plate Brake Light DNL.B6.10000

Thank you for choosing DENALI

We know you would rather be riding your bike than wrenching on it, so we go the extra mile to make sure our instructions are clear and as easy to understand as possible. If you have any questions, comments, or suggestions don't hesitate to give our gear experts a call at 401.360.2550 or visit WWW.DENALIELECTRONICS.COM

Please Read Before Installing

DENALI products should always be installed by a qualified motorcycle technician. If you are unsure of your ability to properly install a product, please have the product installed by your local motorcycle dealer. DENALI takes no responsibility for damages caused by improper installation. **Caution:** When installing electronics is it extremely important to pay close attention to how wires are routed, especially when mounting products to the front fender, front forks, or fairing of your motorcycle. Always be sure to turn the handlebars fully left, fully right, and fully compress the suspension to ensure the wires will not bind and have enough slack for your motorcycle to operate properly.

Installation Tips

We strongly recommend using medium strength liquid thread locker on all screws, nuts, and bolts. It is also important to ensure that all hardware is tightened to the proper torque specifications as listed in your owner's manual. For included accessory hardware please refer to the default torque specifications provided below. Inspect all hardware after the first 30 miles to ensure proper torque specifications are maintained.

Bolt Size	in-lbs	ft-lbs	Nm
M3	10.0 in-lbs	-	1.0 Nm
M4	23.0 in-lbs	-	2.5 Nm
M5	44.5 in-lbs	3.5 ft-lbs	5.0 Nm
M6	78.0 in-lbs	6.5 ft-lbs	9.0 Nm
M8	-	13.5 ft-lbs	18.0 Nm
M10	-	30.0 ft-lbs	41.0 Nm
M12	-	52.0 ft-lbs	71.0 Nm

Hardware Sizing Guide

Not sure what size bolt you have? Use this ruler to measure screws, bolts, spacers, etc. Remember, the length of a screw or bolt is measured from the start of the "mounting surface" to the end of the screw, so only include the screw head when measuring countersunk screws.

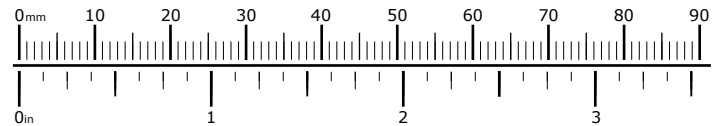

Whats In The Box?



Kit Contents

- (a) B6 Auxiliary LED License Plate Brake Light.....Qty 1
- (b) Wiring Pigtail.....Qty 1
- (c) Posi-Tap.....Qty 3
- (d) M6x16 ISO 7380.....Qty 2
- (e) M6 Washer DIN 125.....Qty 2
- (f) M6 Nut DIN 985.....Qty 2

Tools Required

- 4mm Allen Key
- 10mm Wrench
- Voltmeter/Multimeter

1. Mounting The B6 Brake Light

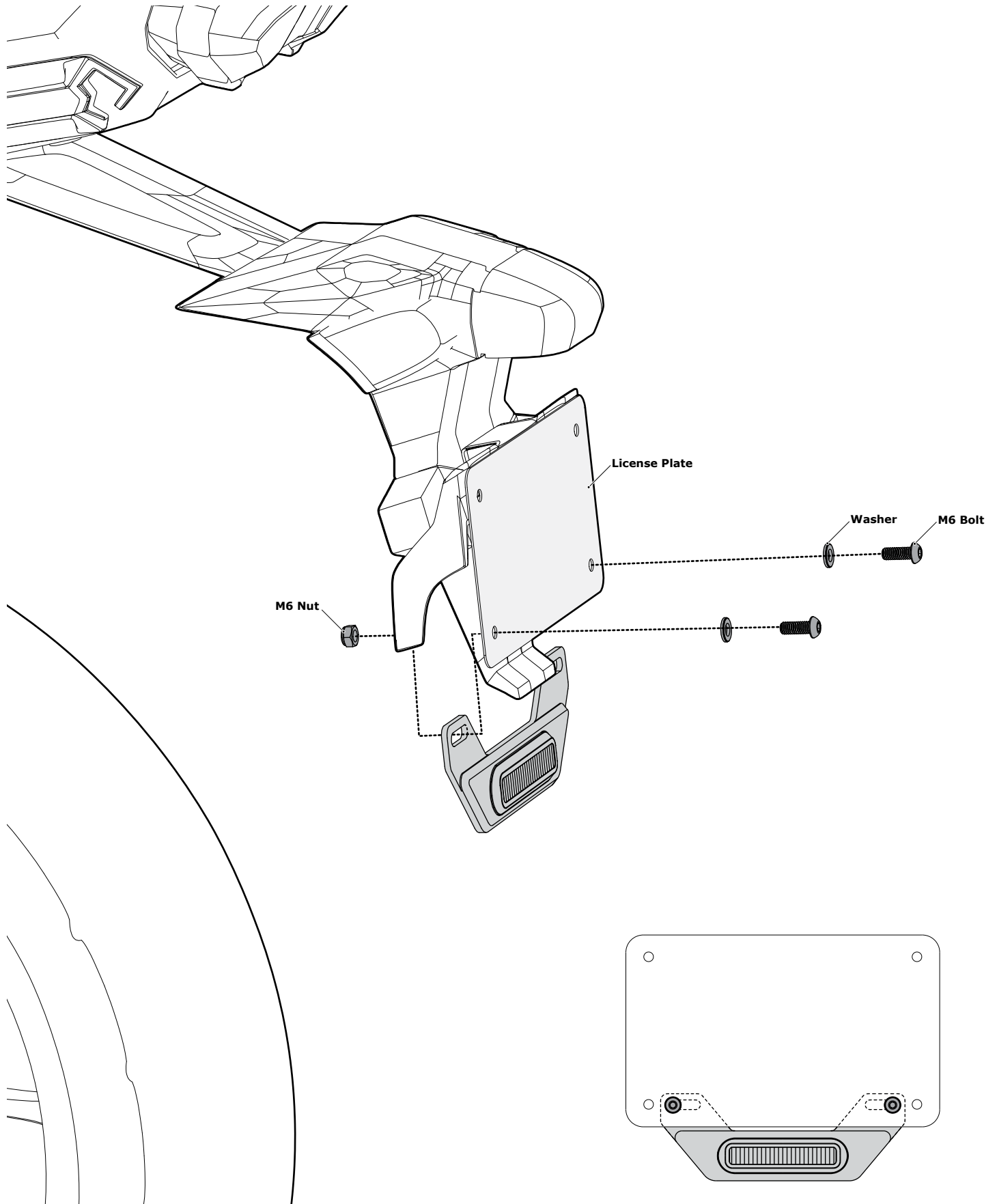

1.1 - Mounting To U.S. Motorcycle Plate

This B6 Auxiliary LED License Plate Brake Light is designed to mount directly to U.S. sized motorcycle license plates.

The brake light is intended to be mounted with the two tabs behind the license plate so that they do not obstruct or cover any of the information on the plate.

Step One: Use the M6 Bolt (d), M6 Washer (e) and M6 Nut (f) to secure the B6 Brake Light (a) to the license plate.

1.2 - Mounting To Larger License Plate

When mounting to larger size license plates it may be necessary to drill additional mounting holes in the plate.

Step One: Center the B6 Brake light (a) to the license plate and mark the two mounting points onto the license plate.

Step Two: Use a 6mm or 1/4" drill bit to drill the two previously marked holes through the license plate.

Step Three: Use the M6 Bolt (d), M6 Washer (e) and M6 Nut (f) to secure the B6 Brake Light (a) to the license plate.

2. Wiring The B6 Brake Light

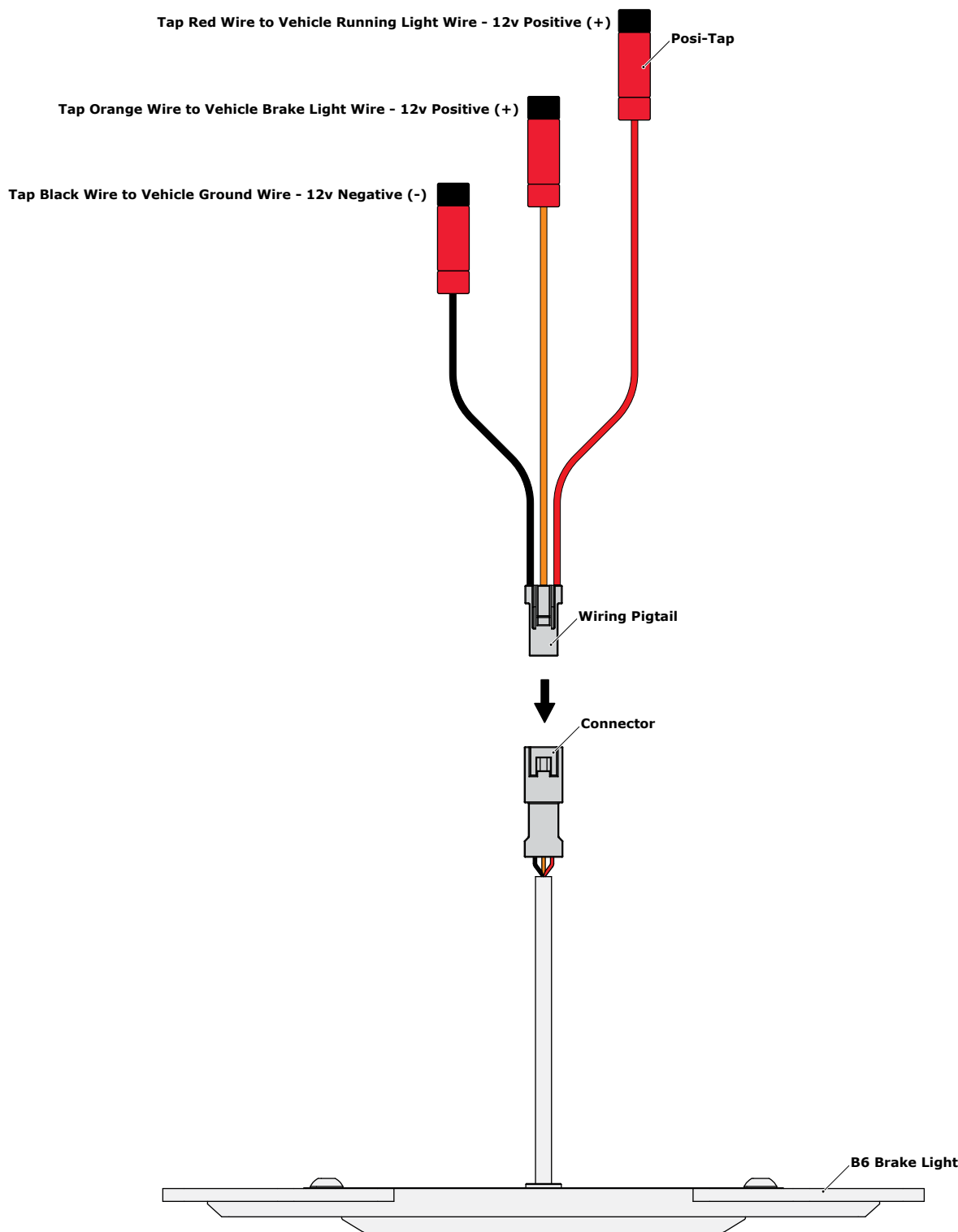

2.1 - Identifying Vehicle Brake Wires

Note: If you are using the B6 Brake Light in conjunction with the DENALI CANsmart Controller, please refer to the instruction manual of the CANsmart Controller for brake light wiring instructions.

BMW Motorcycle Installation: The CAN bus system on most modern BMW motorcycles does not allow the B6 to draw power directly from the factory running light. It is required that you connect the Red Wire to an alternative switched power source such as the accessory socket to prevent failure lights from appearing on the dash. The Orange and Black Wires will still be connected as instructed in Section 2.2.

Step One: Route the cable from the B6 Brake Light into the rear of the motorcycle to the area the factory brake light is located.

Step Two: Identify the wires coming from the factory tail light. There will typically be only three wires exiting the factory brake light housing. You will need to identify the Running Light Wire, Brake Light Wire as

2.2 - Wiring The Pigtail

well as the Ground Wire. Use a voltmeter or multimeter to assist in identifying the correct wires.

Step Three: Use the included Posi-Tap connectors (c) to wire the Pigtail (b) to the wires identified in Step Two.

- Tap the Red Wire to Vehicle Running Light Wire
- Tap the Orange Wire to Vehicle Brake Light Wire
- Tap the Black Wire to Vehicle Ground Wire

Step Four: Plug the Pigtail into the connector on the B6 Module cable.