

PRODUCT DATA SHEET

Product Description: Decorative safety grab bar. 1 1/4" diameter by 48" long. Fabricated from 18-gauge, type 304 grade stainless steel with a US10B powder coated, oil rubbed bronze finish. Welded, 304 grade stainless steel mounting flanges. ADA compliant and designed to support loads in excess of 250 lbs when properly installed. Ships with mounting hardware.

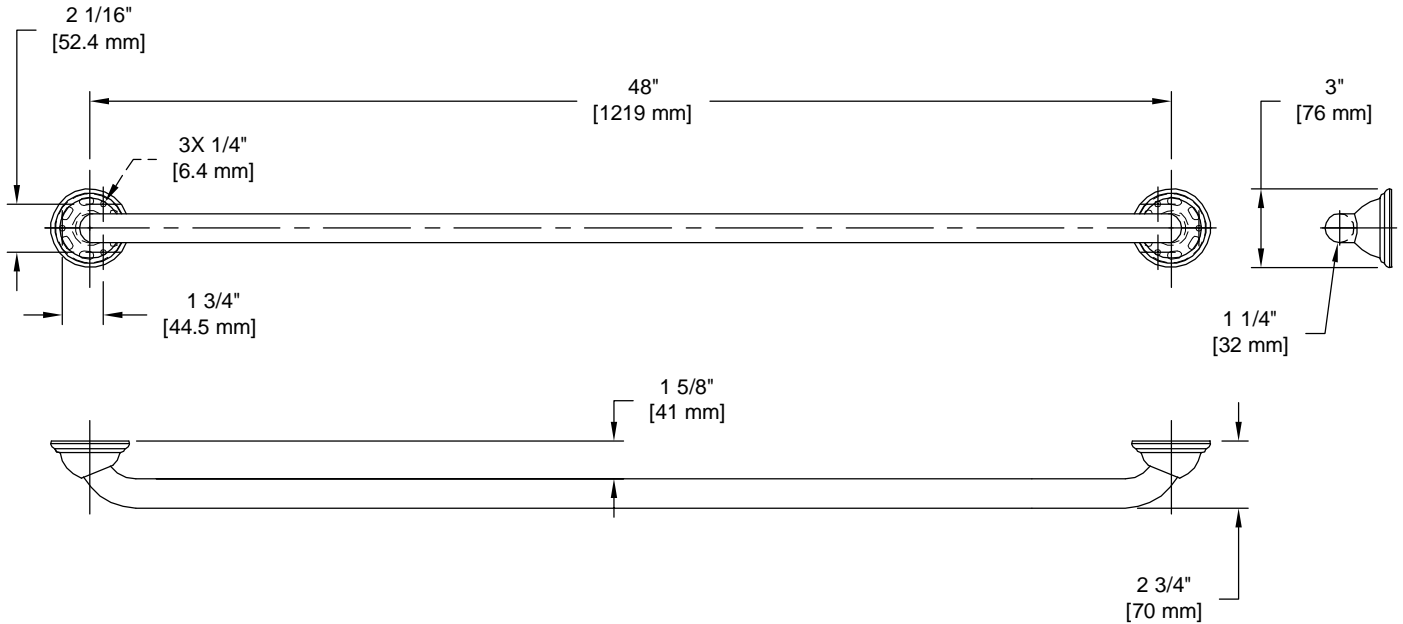

WITH MOUNTING
HARDWARE

ADA

304 STAINLESS

Overall Size: 51 1/4" W X 3 1/4" H X 2 3/4" D

Material: 304 Grade Stainless Steel

Finish: US10B Oil Rubbed Bronze Powder Coated

Cross Reference

Manufacturer	Part Number



Description:

**Grab Bar, 48" Concealed
Screw Dome Escutcheon**

Part Number:

71806

Date

09/16

Rev.

05

Sheet 1 of 1