

# PRODUCT DATA SHEET

**Product Description:** Stainless steel grab bar. 12"+grab bar with 1 1/2"+diameter tube. Fabricated from 18-gauge, type 304 grade stainless steel with a US32D brushed stainless steel finish. Welded, type 304 stainless steel mounting flanges. ADA compliant and designed to support loads in excess of 250 lbs when properly installed. Ships with mounting hardware.

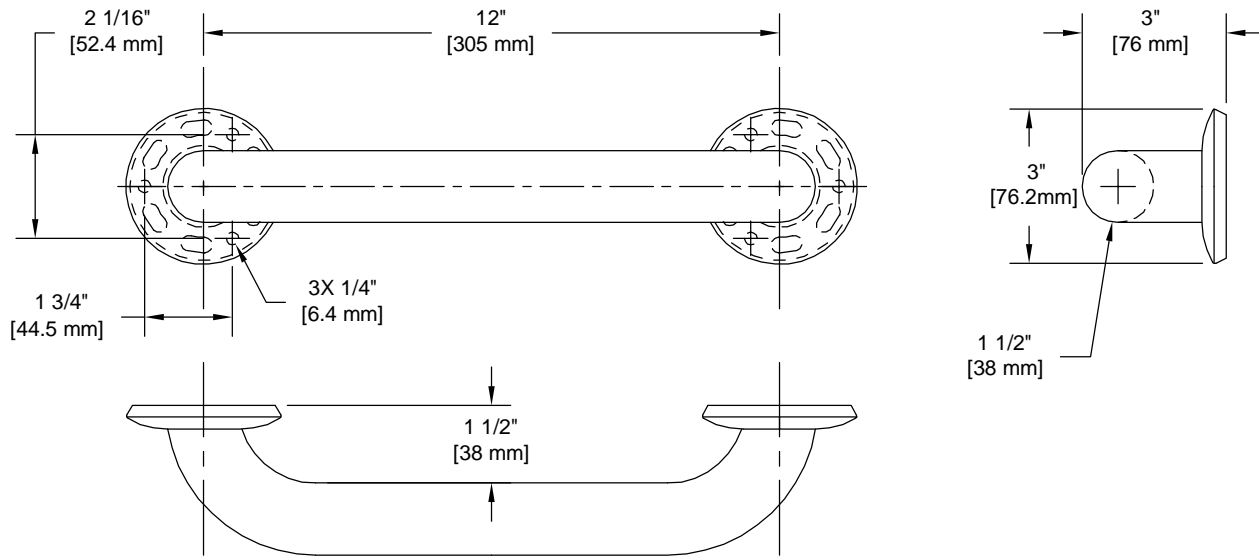

WITH MOUNTING HARDWARE  304 STAINLESS

**Overall Size:** 15 1/4" W X 3 1/4" H X 3" D

**Material:** 304 Grade Stainless Steel

**Finish:** US32D Brushed Stainless Steel

### Cross Reference

Manufacturer	Part Number
Bobrick	B-6806x12



Description:

**Grab Bar, 12" Concealed Screw**

Part Number:

**71760**

Date

09/16

Rev.

06

Sheet 1 of 1