

Emergence of Space and Time from Ultimately Simple Mathematics

Richard Shoup

Boundary Institute
rshoup@boundary.org

March 1, 2015

Abstract: Beginning with Nothing and employing one operation/relation -- Difference -- we show how the foundations of space and time naturally emerge. By simply counting discrete differences properly, a natural definition of position and velocity, a maximum velocity, and relativistic addition of velocities are derived. When differences are arranged in self-referring reentrant expressions, core elements of dynamics also emerge including memory and clocks.

Time is nature's way of keeping everything from happening at once. Space is what prevents everything from happening to me. -- (attributed to) John Archibald Wheeler

Introduction

Despite a multitude of attempts at a Theory Of Everything, the Holy Grail of physics has yet to be found. No one theory has fully succeeded, and there is still great disagreement over the proper primitives, where to start, and even how many universes need explaining. There is a natural and persistent tendency to look at the universe as a mathematical object (Tegmark, 2014), especially given the observed “unreasonable effectiveness” of mathematics in physics and the other natural sciences (Wigner, 1960).

Instead of beginning with a carefully-organized model of particles and fields, or some sort of string-like objects, network loops, lattices, giant Lie groups, sets, axioms, etc., perhaps we need to look deeper, to the basis of the quantum, to the nature of discreteness itself. Perhaps the starting points of the mathematically-based theories have not been fundamental enough. Perhaps we need to start at the very beginning -- with Nothing.

In this informal essay, we start at the very bottom, with Nothing, or *the Void*, prior to anything at all, and then proceed in the smallest conceivable steps. From this ultimately-primitive basis, we will see how to define emergent space and time, the basic

characteristics of velocity including the speed of light and relativity, as well as clocks and memory elements, and the beginning of dynamics.

By the Void, we do not mean the empty set, zero, the vacuum, outer space, etc., but rather literally Nothing (no thing). The Void is not a material or mathematical object.¹ It has no properties or attributes including emptiness, measure or dimensionality. It has no location or place. It has no consequences or effects, and cannot be named, referenced, or pointed to. It is what we indicate or assert by not speaking at all.

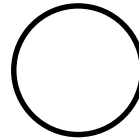

Fig. 1. Nothing/The Void (left) and the First Distinction/Difference (right).

The first and smallest possible step away from Nothing is ... *NotNothing*, simply the first “thing” or abstract object, the first distinction or *difference* from the Void. In discussing emergence of space and time, we will need only this most-basic primitive -- Difference -- in order to begin the emergence of both space and time below. Figure 2 illustrates differences arranged in two ways, but is necessarily only a two-dimensional graphical representation of the more abstract concepts.

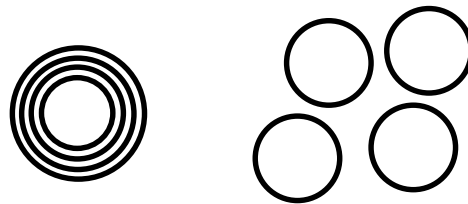

Fig. 2 Ordinal and Cardinal. The ordered sequence of differences (left) can be interpreted as distance (in space or time) between inner and outer areas. The unordered group of differences (right) associates with number or quantity.

Note that while the vast majority of theories in physics and mathematics begin with objects, and then considers differences and relations among them, our approach is the opposite, asserting that *Difference is prior to Object*. In fact, at the most primitive level, objects are only defined by differences. This topic is beyond the scope of this essay.²

About Space

In this section, we explore the simplest possible definition of *motion*, namely a difference or change in *position*. Position in the most primitive case is just the abstract *distance* (count of sequential differences, as above) from the Void. No coordinate or metric or size is

predefined except that of this discrete distance. There is no assumption of pre-existing space or time background, as these will be derived naturally from simple considerations.

Consider a simple discrete motion in one dimension consisting of a sequence of differences of position or *steps* to the left or the right along an imaginary abstract line. Steps take place in one direction or the other, and have no size. There is no clock present, and so an event occurs (one unit of time “passes”) only when there is a change in position.

A typical sequence³ of steps might look like this:

$$+ + - + - + + + \quad (S_1)$$

that is, 6 steps to the right and 2 steps to the left, for a net progress of $6 - 2 = +4$ to the right in the total of 8 steps.

Velocity

It is natural to define a discrete *velocity* just by *counting steps*, as

$$v = \frac{\text{net steps}}{\text{total steps}} = \frac{n^+ - n^-}{n^+ + n^-} ,$$

where n^+ is the number of positive steps and n^- is the number of negative steps. The velocity in this example is then

$$v = \frac{6 - 2}{6 + 2} = \frac{1}{2} .$$

The sequence

$$+ + + + - + + + \quad (S_2)$$

is another example, in this case with velocity $v = (7-1)/(7+1) = 3/4$. Again the total number of steps plays the role of time in our definition of velocity.

Note that velocity is independent of the order of the + and - steps, and is always a fraction of the ultimate speed $c = 1$, a sequence of all + steps (or $c = -1$, being a sequence of all - steps). We need not be concerned with the size of the steps in either spatial or temporal terms -- they are merely indivisible units. (There is no finer distinction in terms of which they could be measured.) Thus $c = \pm 1$ is the natural maximum velocity, being one step in space for each and every step in time.

Addition of velocities

Imagine now a sum of two independent motions defined as above, with one displacement relative to ("added" to) the other. Obviously, there are 4 possibilities for each combined motion: both +, both -, or opposing (+- or -+). This can be illustrated by combining (adding) the two particular sequences above:

$$\begin{array}{rcccccccc}
 S_1: & & + & + & - & + & - & + & + & + \\
 S_2: & & + & + & + & + & - & + & + & + \\
 \text{Sum:} & & + & + & & + & - & + & + & + \ .
 \end{array}$$

Thus the result sequence contains six + and one - motions. In the one case of opposing components in this example, the result is null, no motion, no event at all. For this example, the velocity of the sum is would classically be $(6-1)/8 = 5/8$. However, the sum will only contains 7 total steps, not 8, since +- and -+ motions cancel, see below.

We are only interested in the average velocities, and don't want to depend on any specific alignment of the sequences, so we will next consider addition of velocities in the general case by using a normalized statistical argument.

The general case

In general, these sequences represent independent events that have known distributions (number of + and - steps overall), but which are not in any particular order nor correlated with each other. We will take the probability or density of moves to the right or to the left for a sequence of length N as

$$p^+ = n^+/N \quad \text{and} \quad p^- = n^-/N$$

respectively, where

$$n^+ + n^- = N \quad \text{and} \quad p^+ + p^- = 1 \ ,$$

so the velocity then becomes

$$v = \frac{p^+ - p^-}{p^+ + p^-} \ .$$

First consider the classical sum of two sequences in this form given by

$$v_1 + v_2 = \frac{p_1^+ - p_1^-}{p_1^+ + p_1^-} + \frac{p_2^+ - p_2^-}{p_2^+ + p_2^-} = \frac{2(p_1^+ p_2^+ - p_1^- p_2^-)}{p_1^+ p_2^+ + p_1^+ p_2^- + p_1^- p_2^+ + p_1^- p_2^-} \ .$$

For example, summing the two sequences S_1 and S_2 above *classically* yields

$$v_1 + v_2 = \frac{2 \left(\frac{6}{8} * \frac{7}{8} - \frac{2}{8} * \frac{1}{8} \right)}{\frac{6}{8} * \frac{7}{8} + \frac{6}{8} * \frac{1}{8} + \frac{2}{8} * \frac{7}{8} + \frac{2}{8} * \frac{1}{8}} = \frac{5}{4},$$

in agreement with the common-sense notion of additive velocities, in this case

$$v_1 + v_2 = \frac{1}{2} + \frac{3}{4} = \frac{5}{4},$$

but which of course exceeds the stated and expected maximum velocity of 1.

Derived Time

Suppose we make a simple change to the above sum expression based on the postulate of total steps as our measure of time: *When the summed motion is zero no time passes.* That is, when the two motions are opposite, there is no net motion, thus there is *no event at all*, and our “clock” (the count of total steps) does not increment either. In this model, time is not assumed to pass independently as background, but is derived solely from the combined motions themselves.

Thus the total number of time steps in the denominator of the velocity will not include those cases where the two motions are opposite, namely p^+p^- and p^-p^+ . Only actual net + or - motions of the result are counted in the total steps (time), and all motion is the same abstract size -- one unit. Distances in both space and time emerge (are derived from) counting abstract steps or differences.

Using the *derived time* in this way, the effective velocity now becomes

$$\begin{aligned} v_{1+2} &= \frac{\cancel{p_1^+ p_2^+} - p_1^- p_2^-}{p_1^+ p_2^+ + \cancel{p_1^+ p_2^-} + \cancel{p_1^- p_2^+} + p_1^- p_2^-} \\ &= \frac{p_1^+ p_2^+ - p_1^- p_2^-}{p_1^+ p_2^+ + p_1^- p_2^-} \end{aligned}$$

-- i.e., just that defined by the cases where motion is present in the sum.

Substituting velocities for probabilities again, a little algebra yields

$$v_{1+2} = \frac{v_1 + v_2}{1 + v_1 v_2}$$

which is of course just the addition law under the Lorentz transform of Special Relativity with maximum speed $c = 1$.

In the above example, the correct summed velocity is then

$$v_{1+2} = \frac{\frac{1}{2} + \frac{3}{4}}{1 + \frac{1}{2} * \frac{3}{4}} = \frac{10}{11} ,$$

as expected relativistically, and does not exceed the maximum velocity of $c = 1$.

Interpretation

Here we see the real nature of relative motion and the basis for the space and time dilation of relativity. The “passage” of time is derived from the motion itself and, thus our derived “clock” doesn’t tick when there’s no motion. The usual notions of both space and time emerge naturally from discrete events. This basic approach can be extended to all of Special and General Relativity.

About Time

It is often said that physics cannot be just mathematics, because mathematical expressions “just lie there”, and that they “have no generative power” (Smolin, 2013). Therefore they are static and cannot represent dynamic processes in physics except by deliberate simulation. This is simply not true, as we will now show. Basically, change is detected by comparing with a memory element, which is in turn implemented using differences.

Change, memory, and clocks

Fundamentally, *time is an indicator of change*. Time “passes” when something changes, or to be more specific, when the value of a variable is different from its “previous”⁴ value. The previous value must be something we have remembered, i.e. stored in a *memory* (continually, because time does not pass until something changes). The primitive memory element will be defined in terms of a consistent self-referring expression as seen below. So, in looking for change in some variable, and thus the passage of time, we compare the value of the variable to its value remembered, see Figure 3.

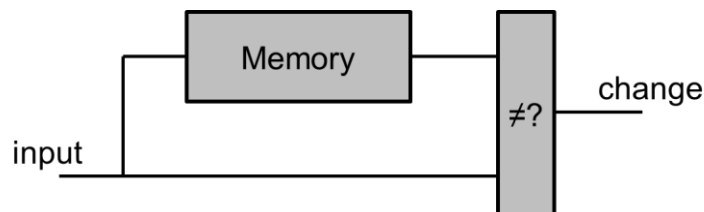

Fig. 3. A change detector compares its input value with the previous stored value. When the values become unequal, time has “passed”, as with a single tick of a clock.

The memory element needed here may be created in the abstract by a self-confirming (looped) tautological expression such as $X = X$, or, reading the basic difference operation as inversion (logical NOT), by a double inversion $X = \sim\sim X$, see Figure 4. Note that logical inversion is exactly the primitive operation of difference or distinction -- crossing the boundary -- that we postulated above.

Interestingly, the similar but *paradoxical* self-denying logic expression with a single inversion $X = \sim X$ creates a *clock*, an oscillator. This is exactly a paradox of the form “This sentence is false.”⁵ The result is false if true and true if false, and therefore oscillates between the two values at an undefined abstract frequency. The result is a pure entropy generator, producing continual change -- the opposite of a memory.

Using only difference and self-reference or reentrance, we can create an abstract memory and a clock, the most fundamental and essential time-related elements of any computer, and the basis for dynamics in physics as well.

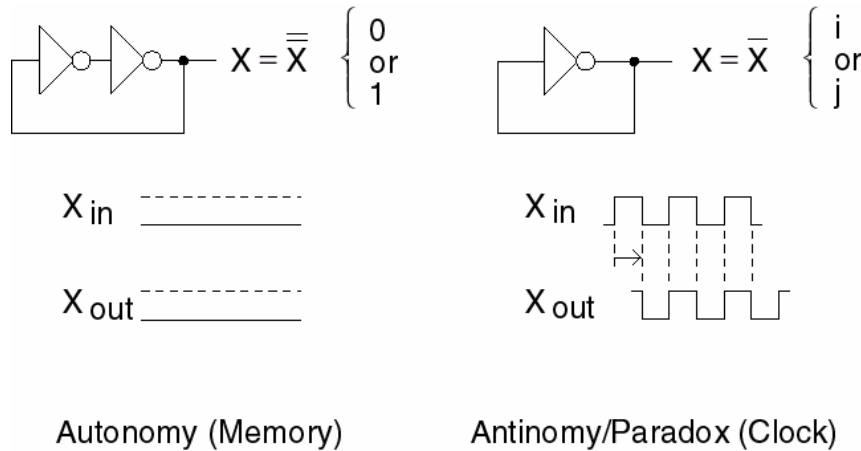

Fig. 4. Memory and Clock as simple logic circuits. The triangular elements represent inversion, or logical NOT.

By counting these changes in a clock or similar abstract system, we can define and determine a *discrete time interval* or integer “length” of time, just as any conventional watch or clock does, whether mechanical or electronic. This simple model suggests the ultimate origin of time, and how it can be generated and understood at the deepest level. In the prior section, we saw how a proper accounting of time in discrete motion naturally leads to the velocity and addition of velocities.

Further, consider the bits of a binary counter modeled similarly. Each bit is itself a paradox or clock gated by the change of state of the prior (lower-order) bit, and thus

oscillates at half its predecessor's frequency. By combining various of these bits with some additional logic, any arbitrary digital waveform can be easily synthesized, see for example Vuillemin (1994, 2003).

Thus any imagined dynamic or reactive behavior may be generated based upon the simple operations of difference arranged in self-referring mathematical expressions. Mathematics is generative, dynamic, and alive.

Summary and remarks

This essay attempts to demonstrate the potential for, and point in the direction of, a true discrete physics based on the deepest possible foundations, the fewest possible assumptions (none), and ultimately the most general and unified theory of everything. Starting from nothing, and with one simple basic idea -- Difference -- we see the beginnings of both space and time, and their primitive properties.

In order for this approach to be shown valid and useful, a great deal of additional work needs to be done to fully connect these basic concepts to existing completed models of particle interactions, forces and fields, relativity, and quantum phenomena.

Acknowledgements

To the best of my knowledge, the basic idea of deriving additive velocities in Special Relativity presented here was first developed in part and published by David McGoveran and Pierre Noyes (1989) to the physics group Alternative Natural Philosophy Association in Cambridge, England, then was later clarified and presented by physicist Irving Stein (1996), and later rediscovered and extended by Thomas Etter (1998) as well. Similar and related ideas were also discussed by K. Brown on his web site "Math Pages" (undated).

I am grateful for numerous discussions on these subjects with George Spencer-Brown, William Bricken, Thomas Etter, Andrew Singer, Kenneth Wharton, James Bowery, and David McGoveran.

¹ Although one might say it is the *contents* of the empty set.

² A calculus of distinctions is discussed at length in *Laws of Form* (Spencer-Brown, 1969), a book sometimes erroneously thought of as only a reformulation of Boolean algebra. For more on the origins of space as distinctions, and time as generated by loops in space, see Shoup (1994).

³ We use the word "sequence" here not in the sense of a time series, but as an order relation.

⁴ Again, the word "previous" does not refer to a prior time, but to a neighbor in an abstract order.

⁵ This is similar but not identical to the classic paradox of Epimenides the Cretan "All Cretans are liars."

References

- Brown, K., "Probabilities and Velocities",
www.mathpages.com/home/kmath216/kmath216.htm.
- Etter, T. and Noyes, H. P., "Process, System, Causality, and Quantum Mechanics",
Stanford Linear Accelerator Center Pub 7890, 1998; revised in *Physics Essays*, 12, 4,
Dec. 1999, also available at <http://www.boundary.org/bi/articles/PSCQM.pdf>.
- McGoveran, D., and Noyes, P., "Foundations of a Discrete Physics", SLAC-PUB-4526,
Stanford Linear Accelerator Center, 1989, also available at
http://www.boundary.org/bi/articles/McGoveran_-_Discrete_Physics-89.pdf
- Spencer-Brown, G., *Laws of Form*, George Allen & Unwin, 1969; Julian Press, 1972;
Bantam, 1973; Dutton, 1979; Cognizer, 1994; Bohmeier Verlag, 1997, 1999, 2008.
- Shoup, R., "Space, Time, Logic, and Things", *PhysComp '94 Workshop on Physics and
Comp*, IEEE Press, 1995, and <http://www.rgshoup.com/prof/pubs/SpaceTime.pdf>.
- Smolin, L., *Time Reborn*, Houghton Mifflin Harcourt, 2013.
- Stein, I., *The Concept of Object as the Foundation of Physics*, Peter Lang, 1996.
- Tegmark, M., *Our Mathematical Universe*, Knopf, 2014.
- Vuillemin, J., "Digital Algebra and Circuits", *Verification - Theory and Practice, Lecture
Notes in Computer Science*, Springer-Verlag, Vol. 2772, 100-120, 2003.
- Vuillemin, J., "On circuits and numbers", *IEEE Trans. on Computers*, 43:8:868-79, 1994.
- Wigner, E. P., "The Unreasonable Effectiveness of Mathematics in the Natural
Sciences", *Comm. on Pure and Applied Mathematics* 13: 1-14, 1960.