



The University of
Nottingham

UNITED KINGDOM • CHINA • MALAYSIA

QUANTUM CORRELATIONS

WHAT ARE THEY GOOD FOR?

GERARDO ADESSO

arXiv:1309.1472

WHAT IS QUANTUM?

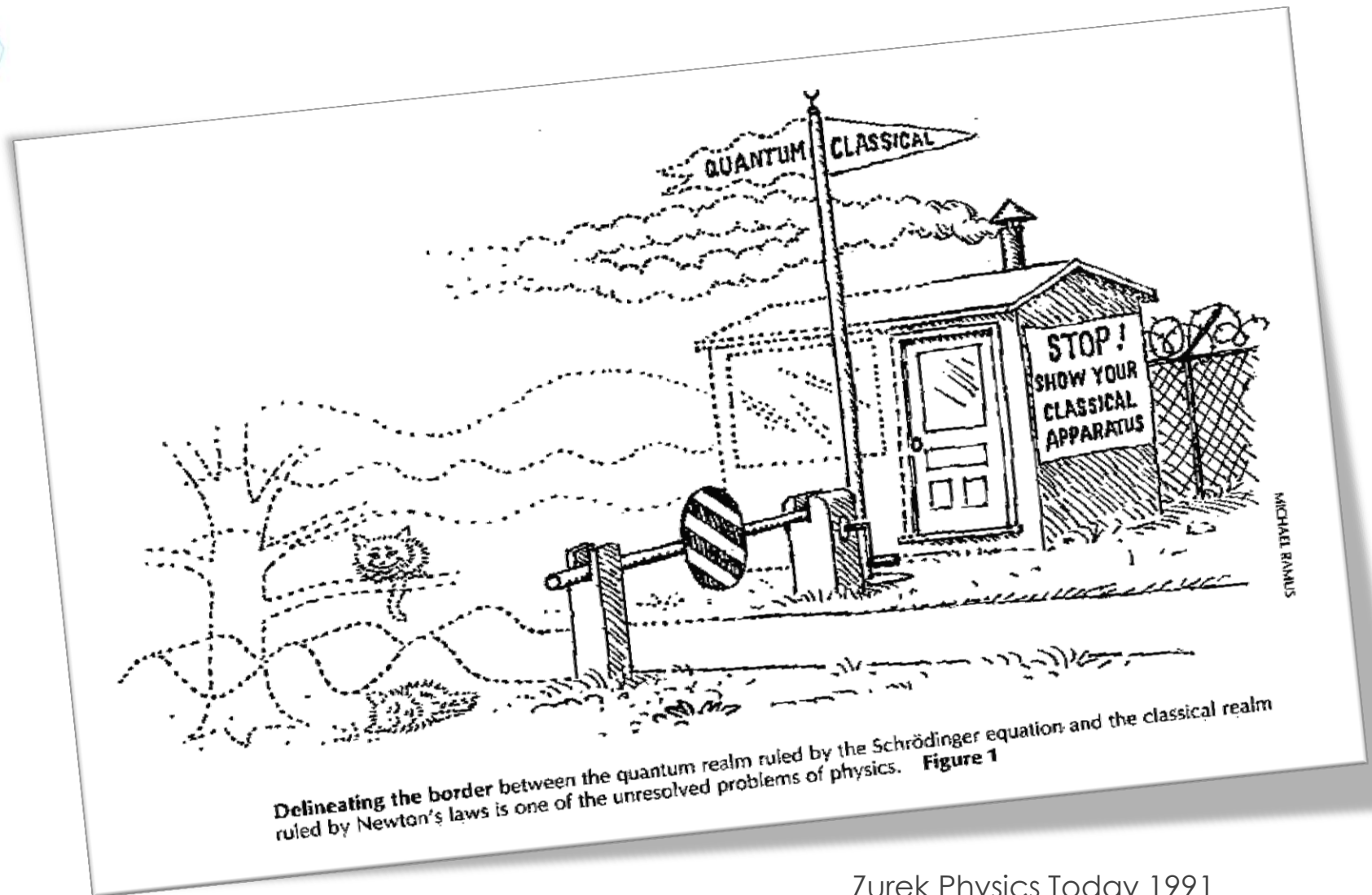

CORRELATIONS

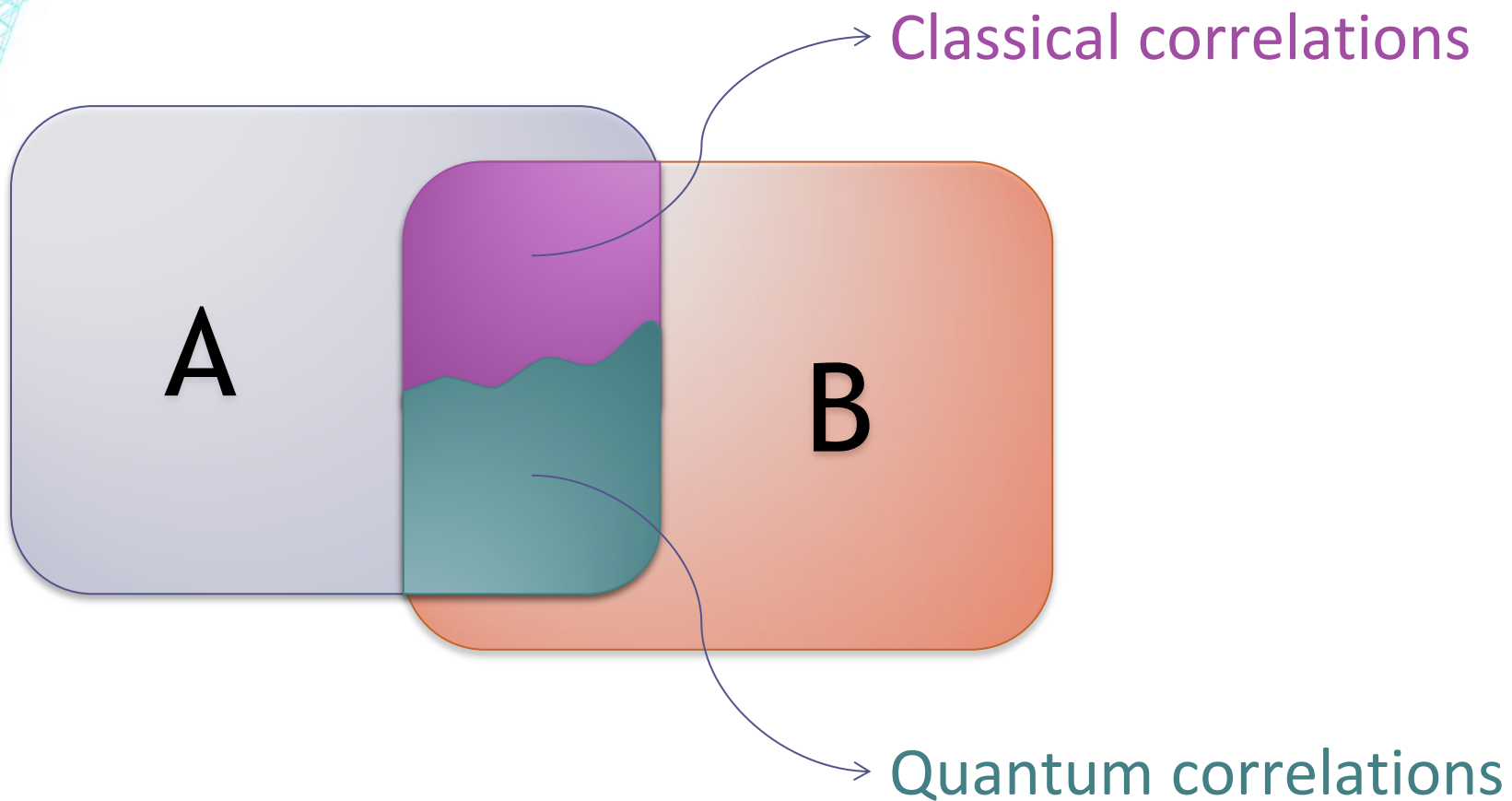

CORRELATIONS

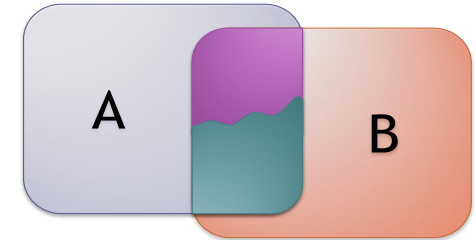

- **Pure bipartite states:**

- **entanglement** = nonlocality
nonclassicality (quantum correlations)

- **Mixed bipartite states:**

- *Werner 1989*: separable classically correlated



QUANTUMNESS IN SEPARABLE STATES

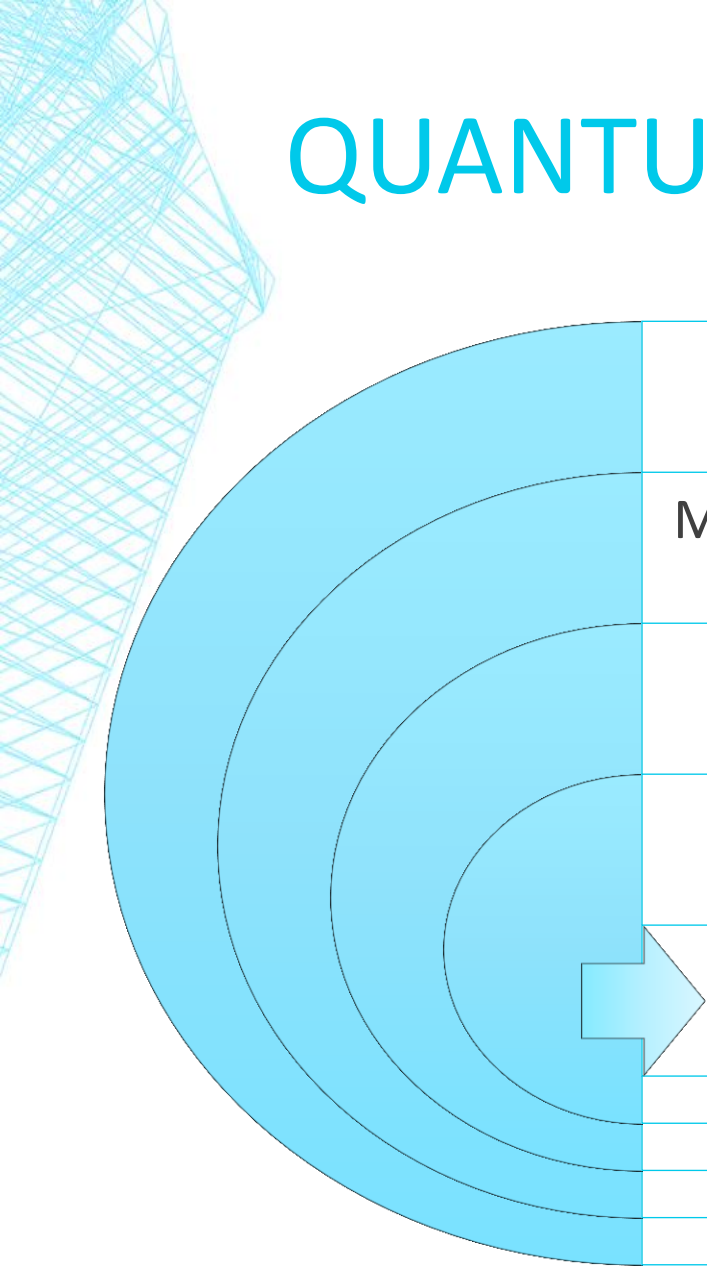

Nonorthogonal separable states cannot be discriminated exactly

Measuring a local observable on a separable bipartite state can perturb the state

The eigenvectors of a separable state can be entangled superpositions

.....

In general separable states *have not* a purely classical nature

QUANTUM DISCORD

a signature of
quantumness in
correlated states
(including separable)

can be revealed by the
necessary disturbance
due to any local
measurement

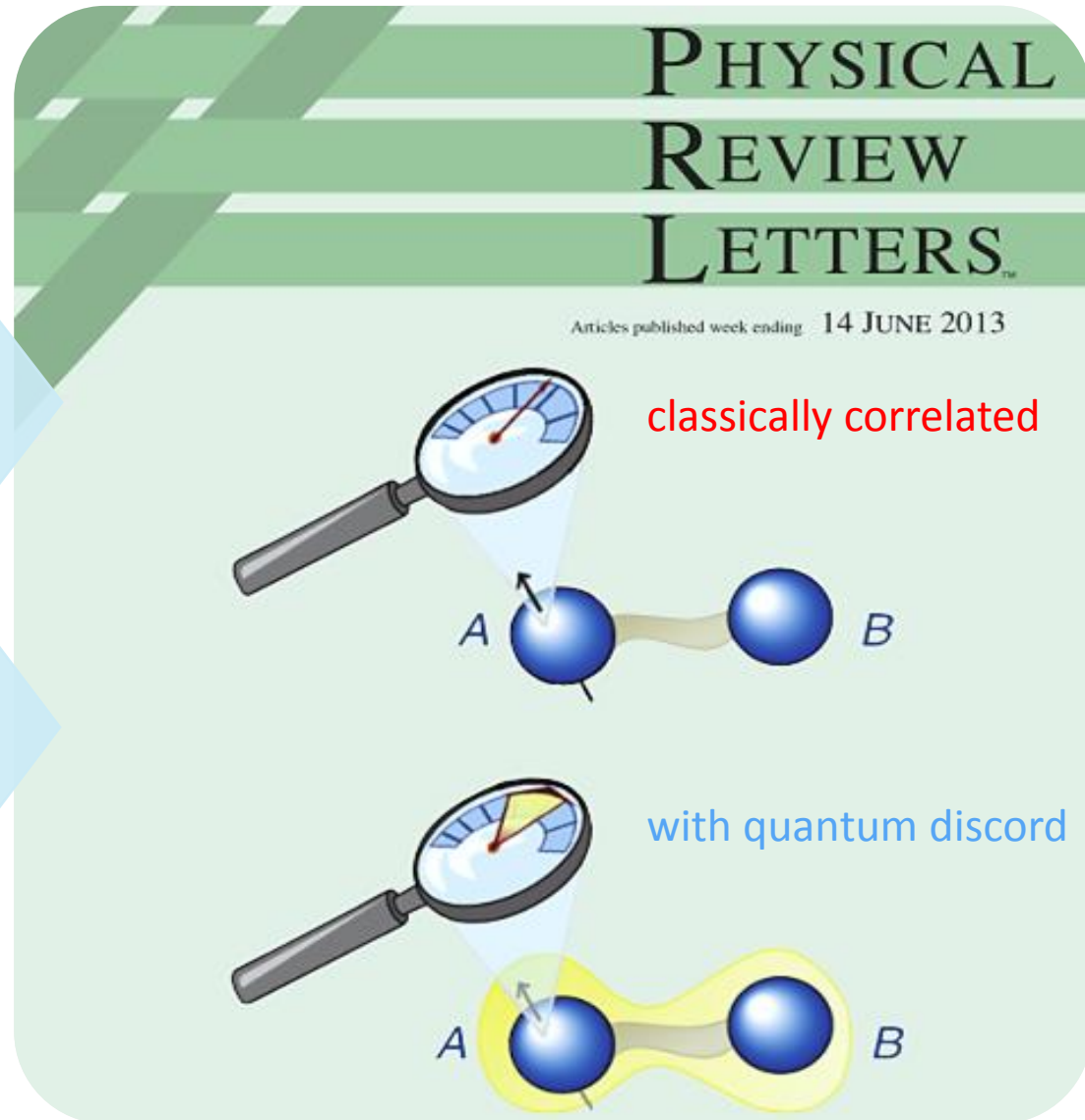

H. Ollivier, W. H. Zurek, *Phys. Rev. Lett.* 2001
D. Girolami, T. Tufarelli, G. A., *Phys. Rev. Lett.* 2013
review: K. Modi *et al. Rev. Mod. Phys.* 2012)

CORRELATIONS

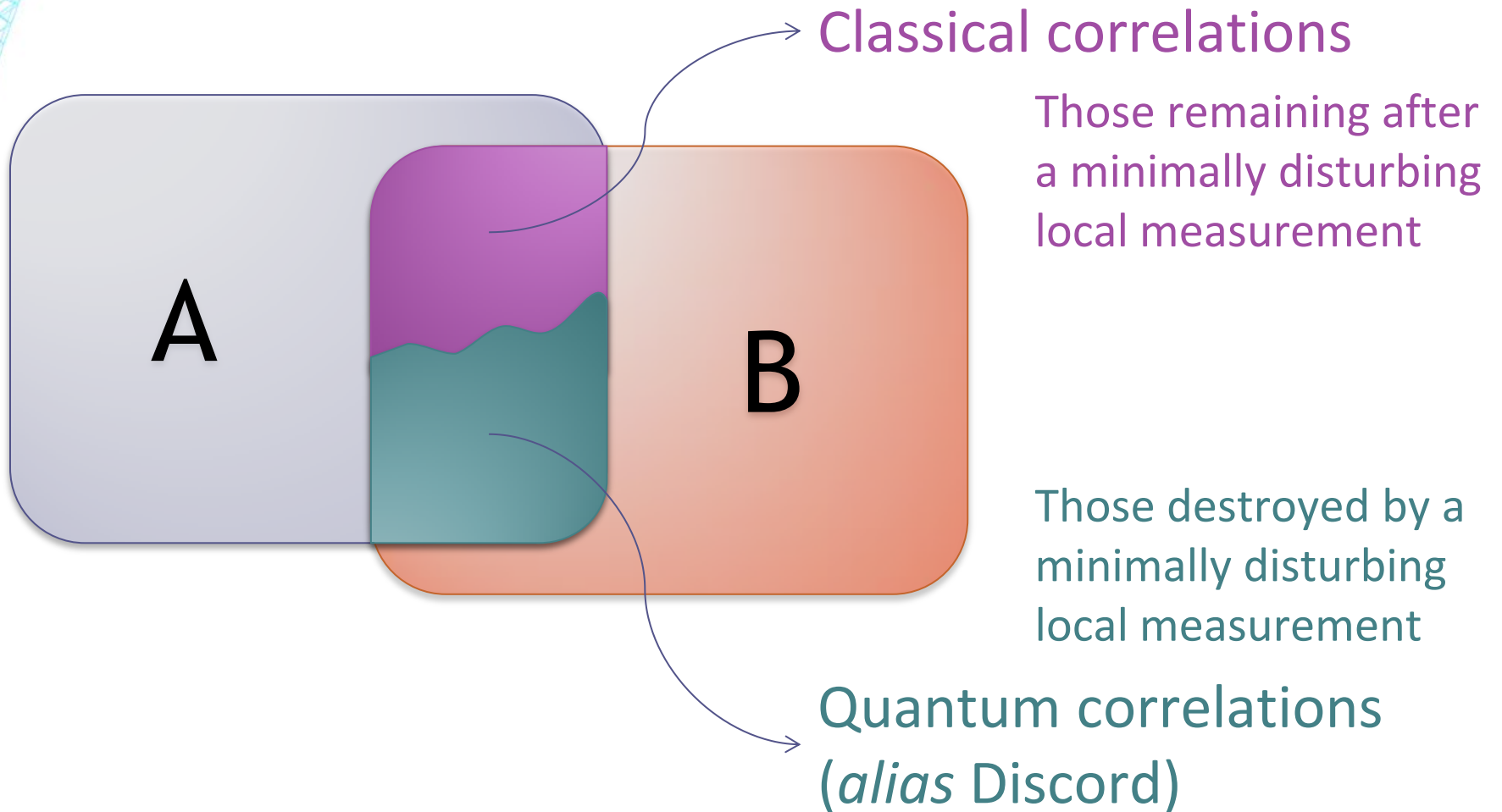

3 SHADES OF QUANTUMNESS

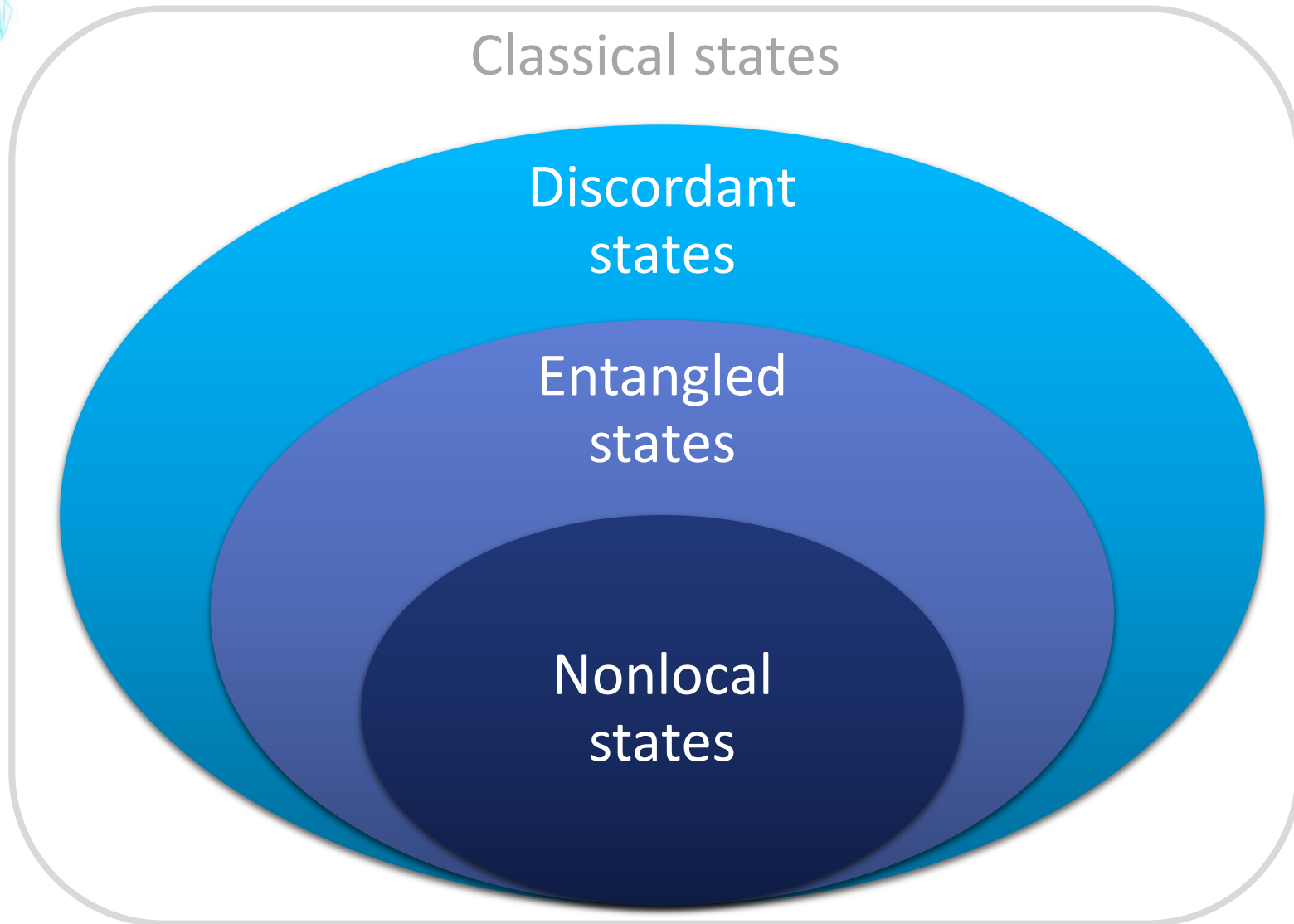

QUANTUM CORRELATIONS

WHAT ARE THEY GOOD FOR?

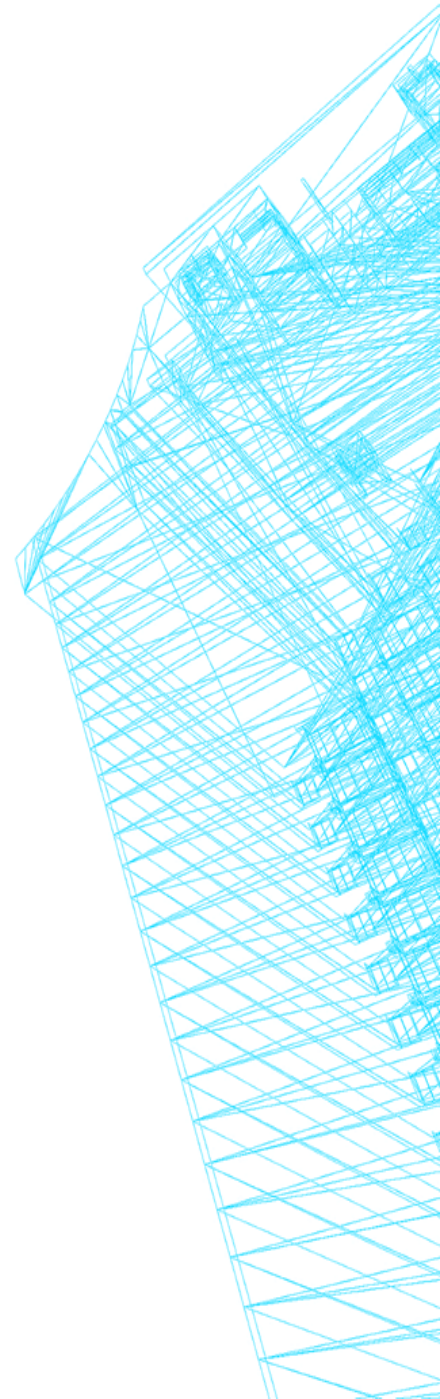

Nature June 2011

THE POWER OF DISCORD

BY ZEEYA MERALI

Physicists have always thought quantum computing is hard because quantum states are incredibly fragile. But could noise and messiness actually help things along?

FEATURING

- A - G. A.
- B - D. Girolami
- C - T. Tufarelli
- D - V. Giovannetti
- E - J. Filgueiras
- F - D. Soares-Pinto
- G - A. Souza,
R. Sarthour,
I. Oliveira



FQXi

CIÊNCIA
SEM FRONTEIRAS

QUANTUM METROLOGY



exploits quantum mechanical features



to improve the available precision



in estimating physical parameters

PHASE ESTIMATION

TASK

- Given the generator H_A
- Find the phase φ

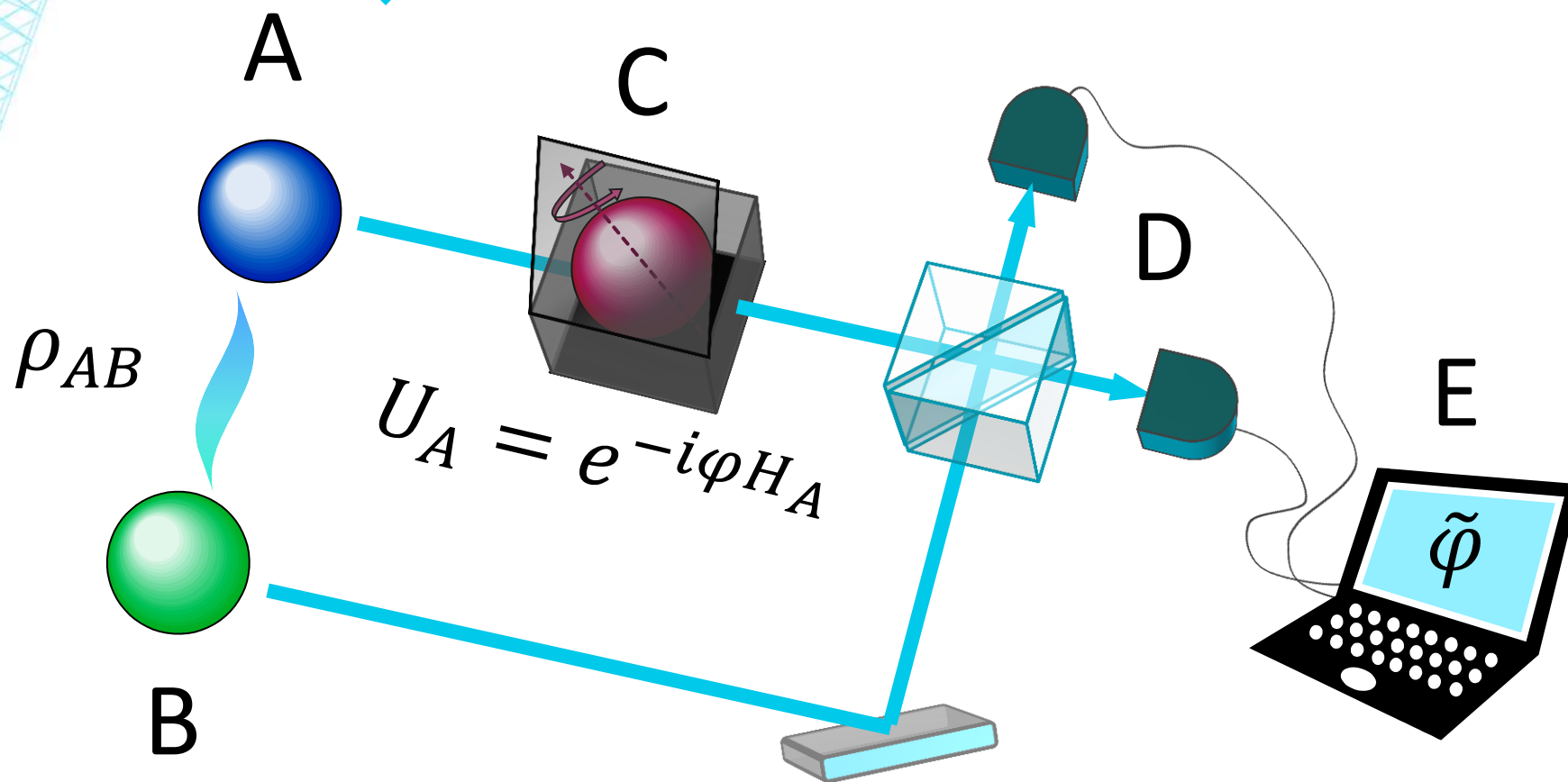

PHASE ESTIMATION

ν times

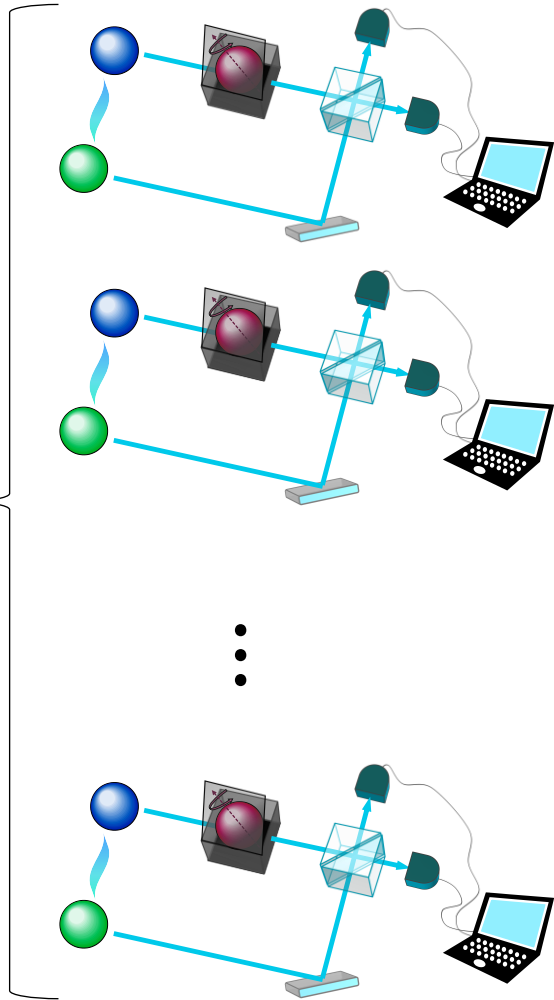

Quantum Cramer-Rao Bound

$$\text{Var}(\tilde{\varphi}) \geq 1/[\nu F(\rho_{AB}; H_A)]$$

Quantum Fisher Information

$F(\rho_{AB}; H_A)$ measures the precision

Entanglement is not necessary

coherence in the eigenbasis of H_A is

ONE-FITS-ALL QUANTUM METROLOGY

let the phase generator be unknown *a priori*...

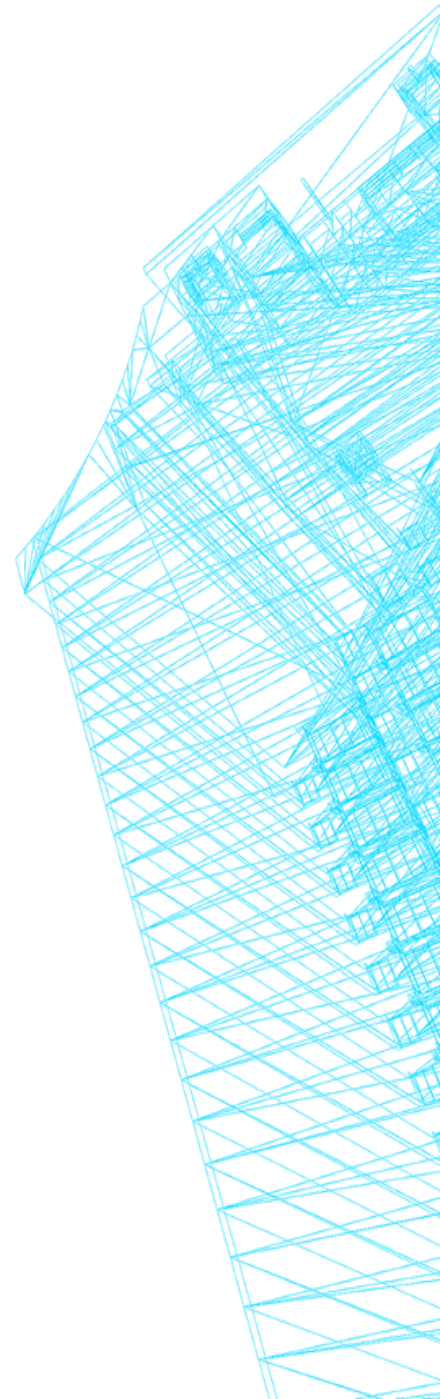
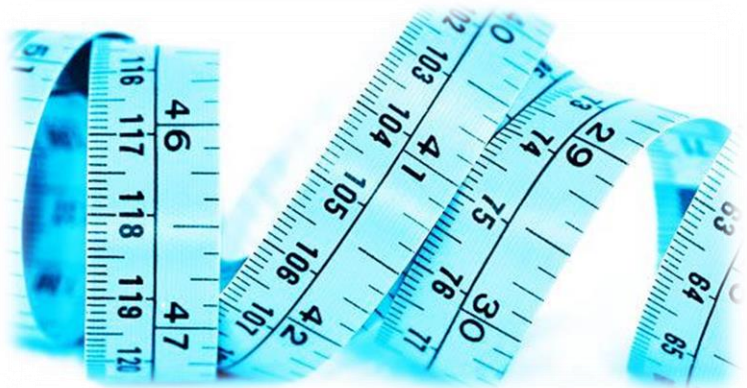

ONE-FITS-ALL PHASE ESTIMATION

TASK

- The generator H_A is revealed after ρ_{AB} is prepared
- Find the phase φ

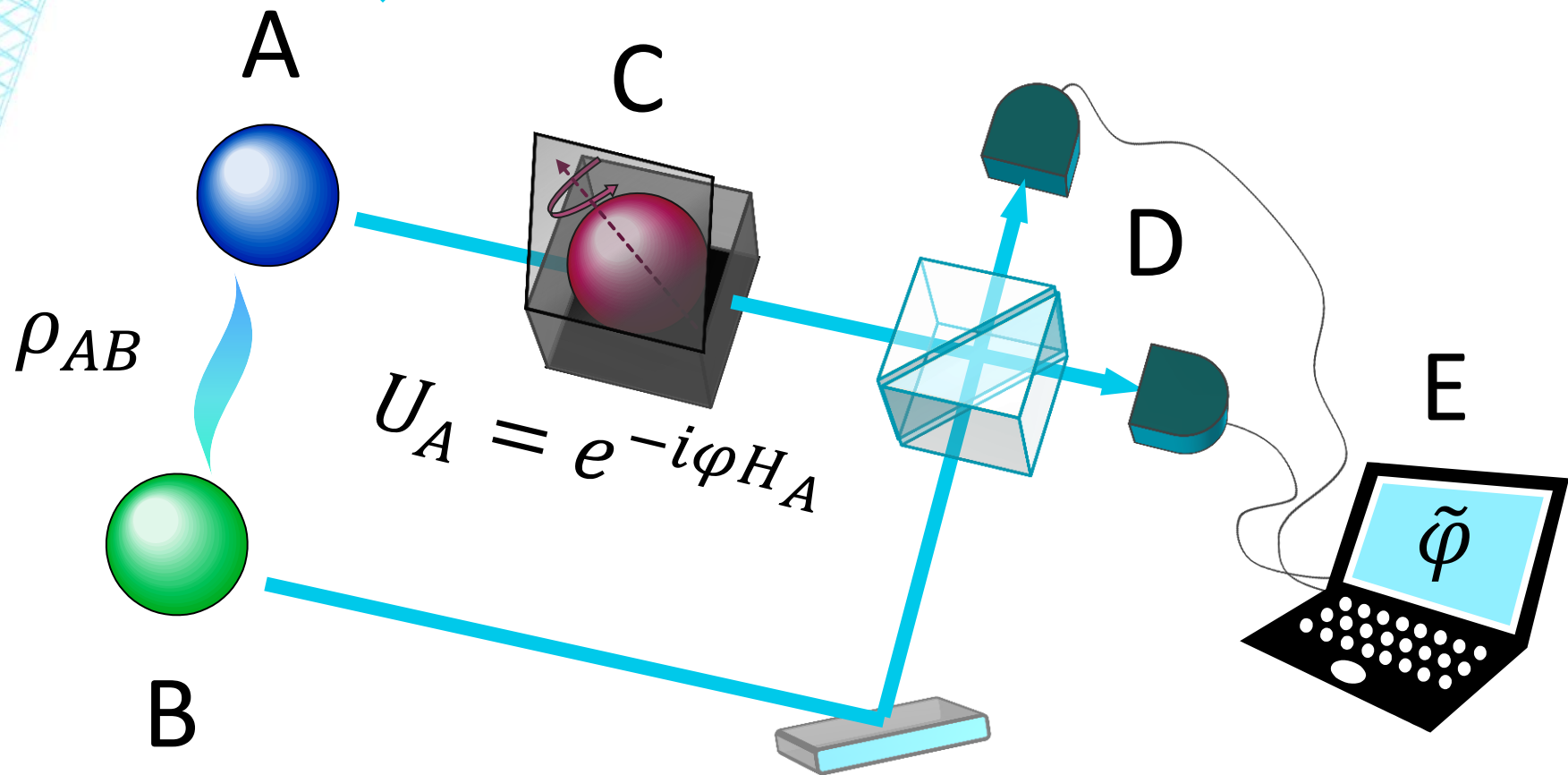

ONE-FITS-ALL PHASE ESTIMATION

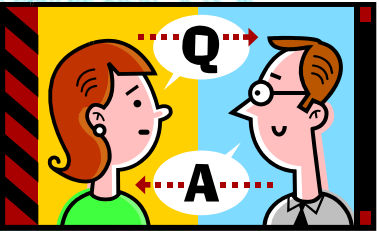

TASK

- The generator H_A is revealed after ρ_{AB} is prepared
- Find the phase φ

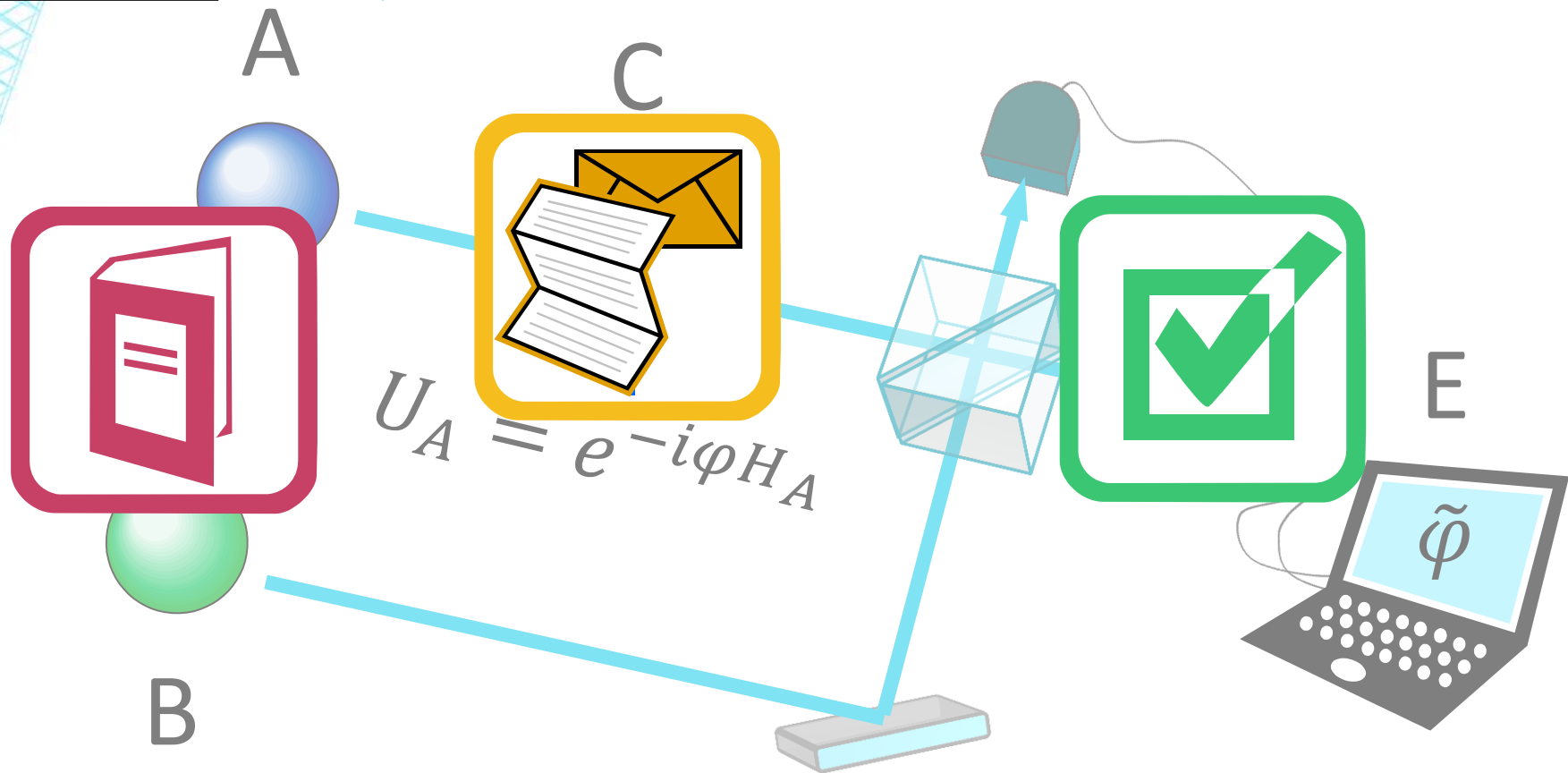

WHICH *ONE-FITS-ALL*
INPUT PROBE STATES
GUARANTEE A PASS?

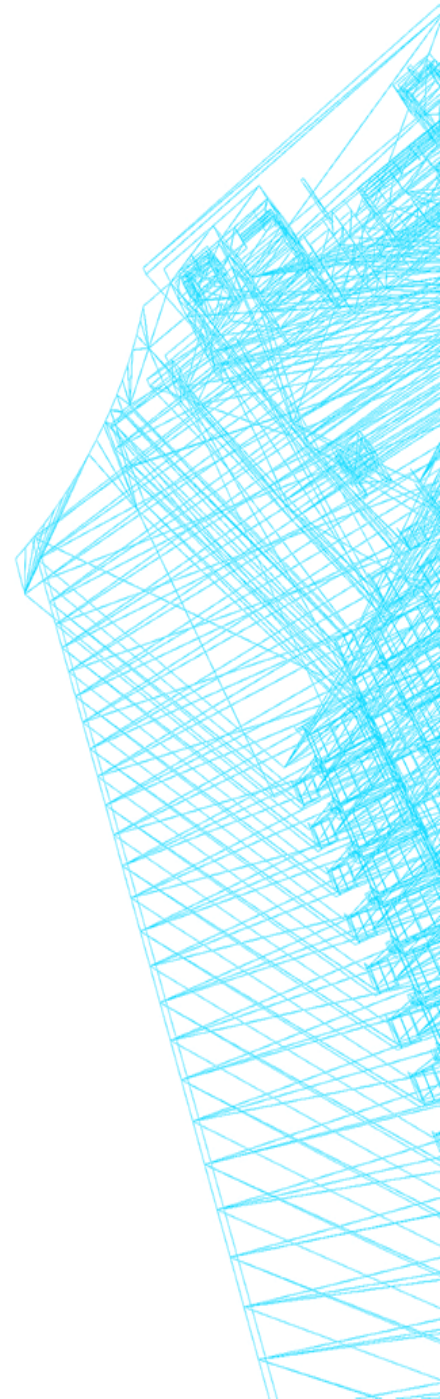

WORST-CASE SCENARIO

FIGURE
OF
MERIT

- How useful the probe state ρ_{AB} is for estimation
- Guaranteed precision for any possible phase generator

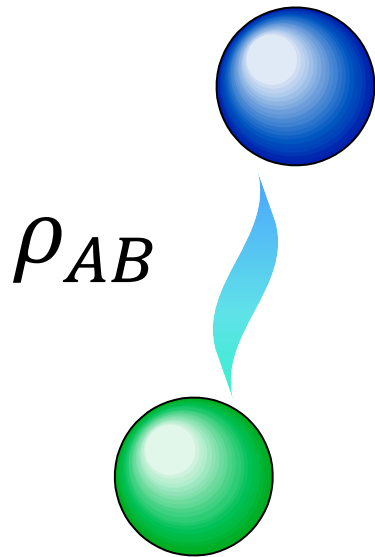

$$P(\rho_{AB}) = \frac{1}{4} \inf_{H_A} F(\rho_{AB}; H_A)$$

INTERFEROMETRIC POWER

QUANTUM DISCORD IS THE RESOURCE

FIGURE OF MERIT

- The task requires coherence in the eigenbases of all H_A 's
- **The interferometric power is a measure of discord**

$$P(\rho_{AB}) = \frac{1}{4} \inf_{H_A} F(\rho_{AB}; H_A)$$

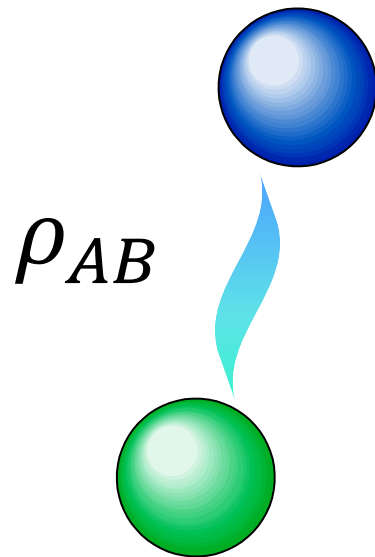

- P is invariant under local unitaries and nonincreasing under local operations on B
- It vanishes iff ρ is classically correlated, $\rho_{AB} = \sum_i p_i |i\rangle\langle i|_A \otimes \tau_{iB}$
- It reduces to an entanglement monotone for pure states
- It is analytically computable if A is a qubit

QUANTUM DISCORD GUARANTEES AND QUANTIFIES THE PRECISION

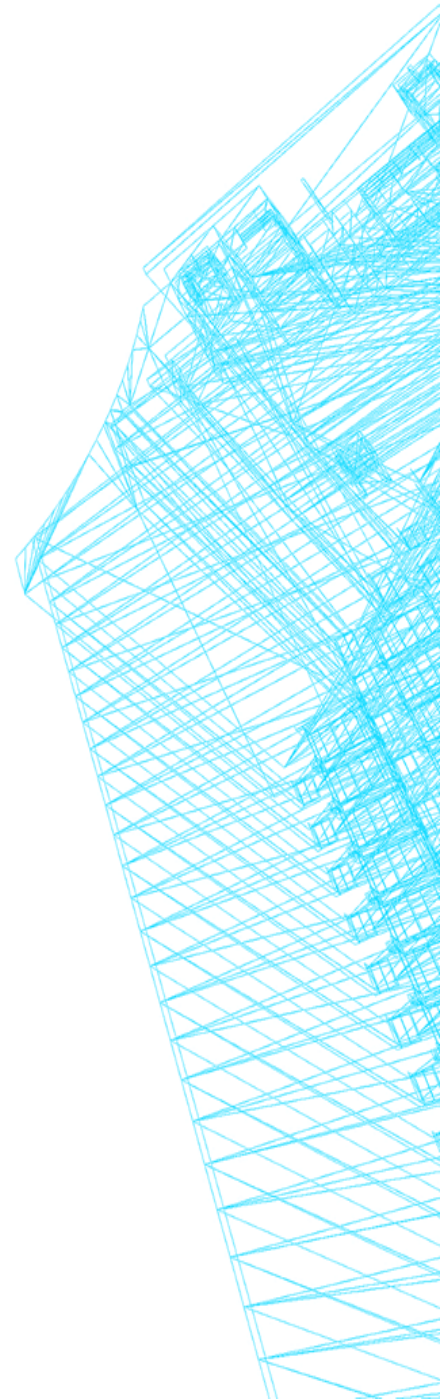

2 CLASSES OF STATES

K. Modi *et al.* *Phys. Rev. X* 2011

$$\rho_{AB}^C = \frac{1}{4} \begin{pmatrix} 1 & p^2 & p & p \\ p^2 & 1 & p & p \\ p & p & 1 & p^2 \\ p & p & p^2 & 1 \end{pmatrix}$$

classically correlated

$$\rho_{AB}^Q = \frac{1}{4} \begin{pmatrix} 1+p^2 & 0 & 0 & 2p \\ 0 & 1-p^2 & 0 & 0 \\ 0 & 0 & 1-p^2 & 0 \\ 2p & 0 & 0 & 1+p^2 \end{pmatrix}$$

with quantum discord

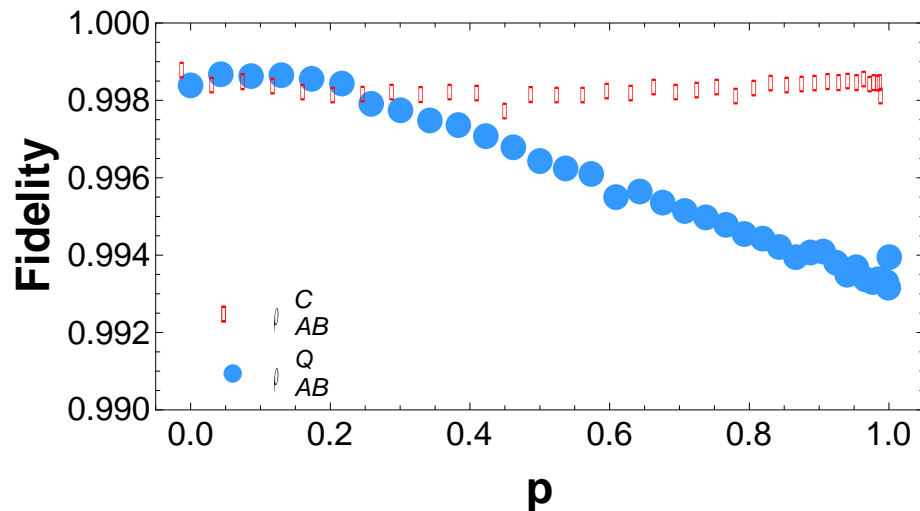

EXPERIMENT

with Nuclear Magnetic Resonance

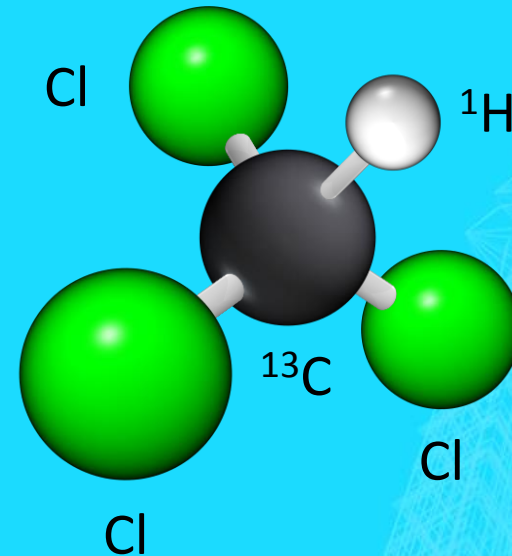

3 HAMILTONIANS

1. σ_{z_A}

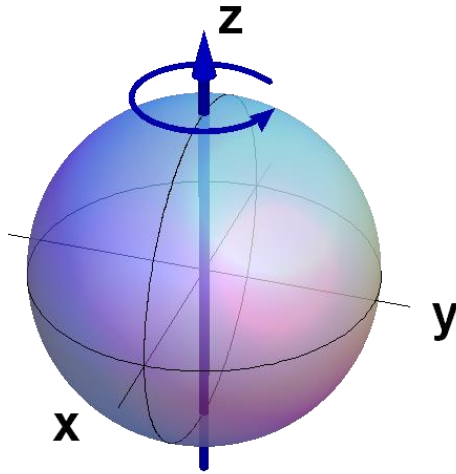

2. $(\sigma_{x_A} + \sigma_{y_A})/\sqrt{2}$

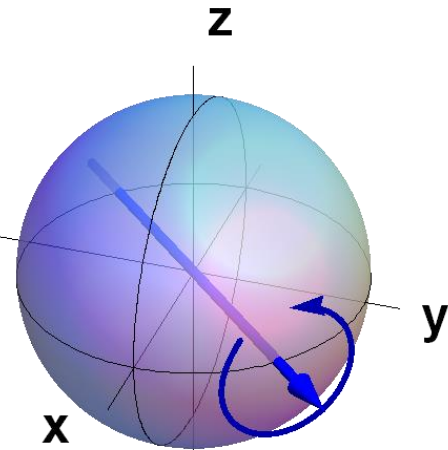

3. σ_{x_A}

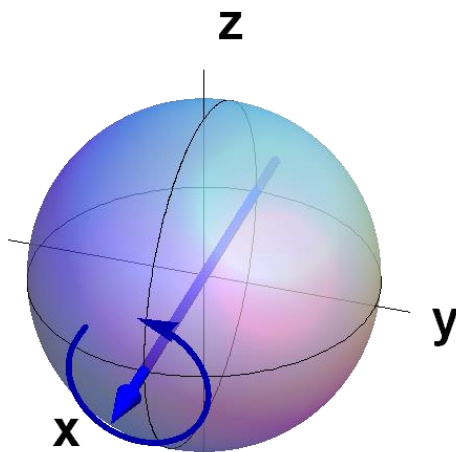

EXPERIMENT

with Nuclear Magnetic Resonance

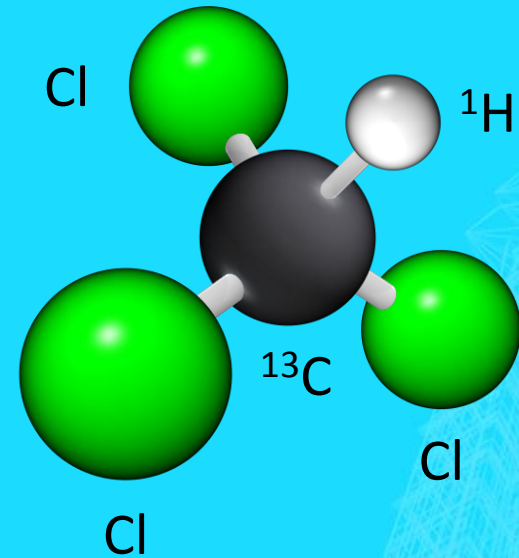

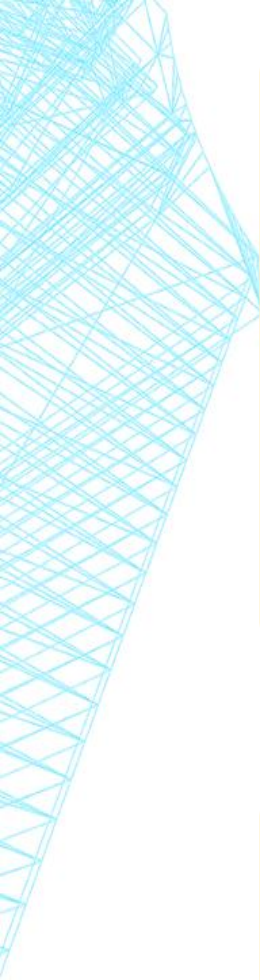

SCHEME

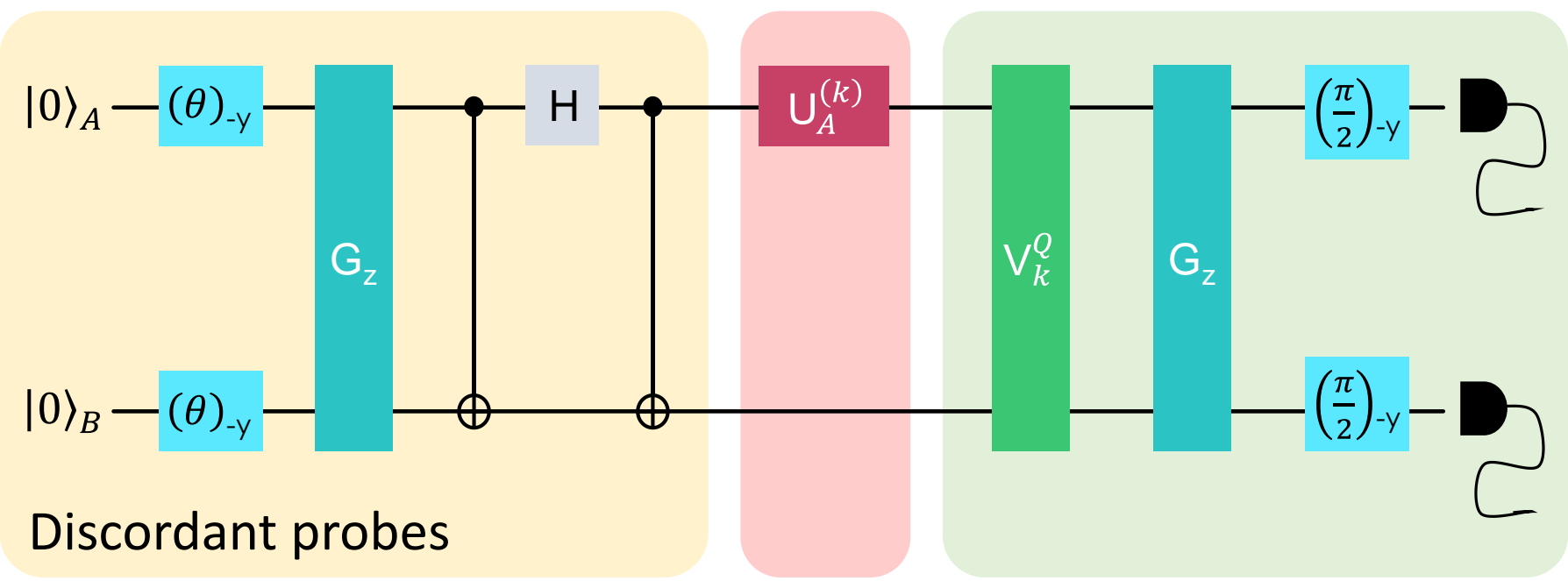
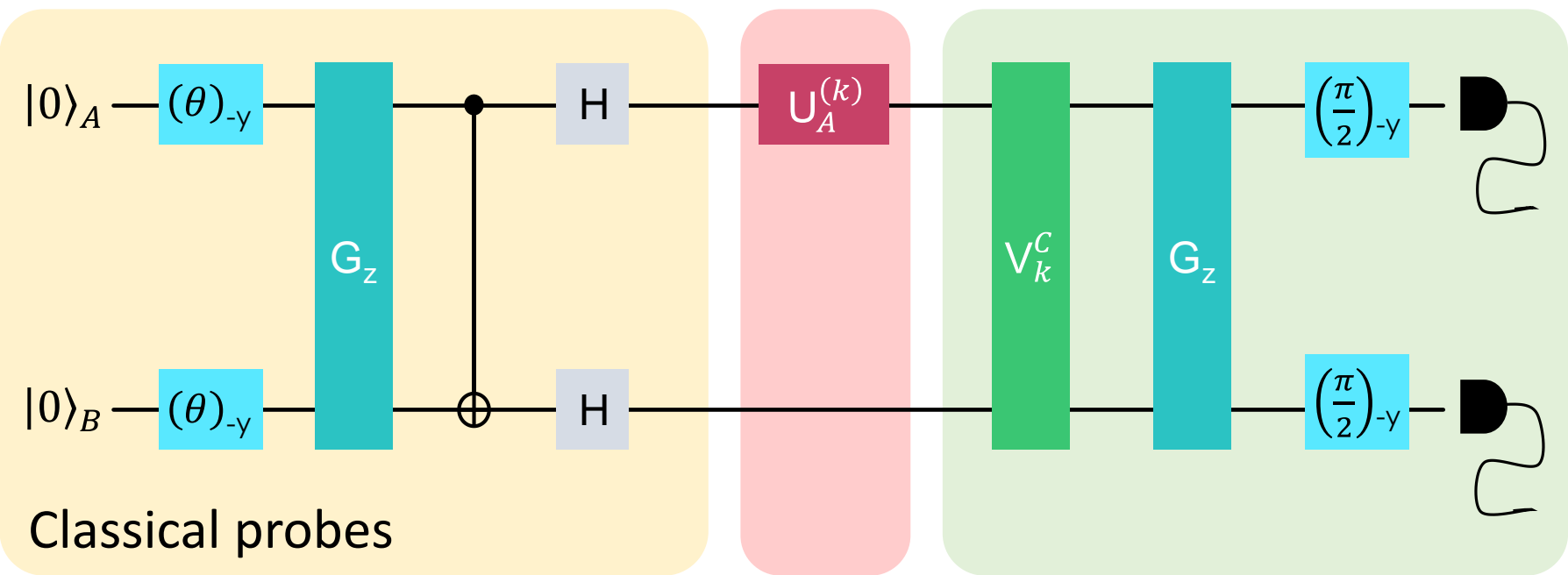

RESULTS

Precision

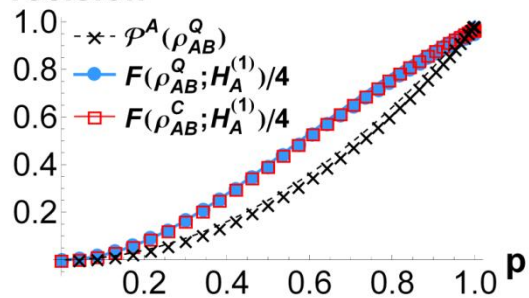

Var($\tilde{\varphi}$)

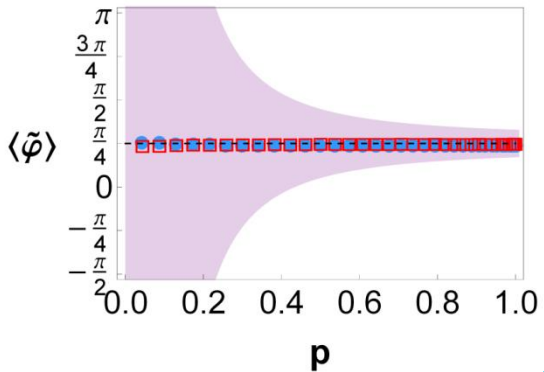
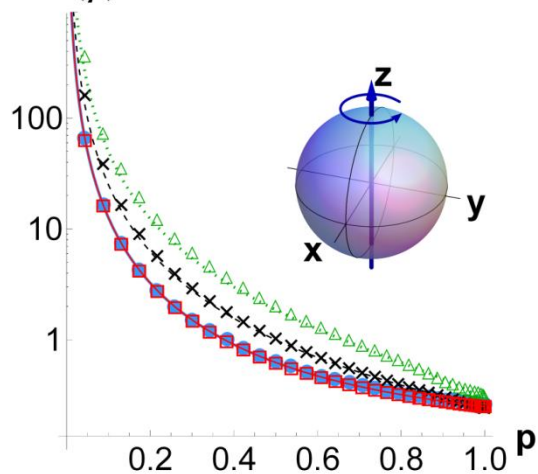

Precision

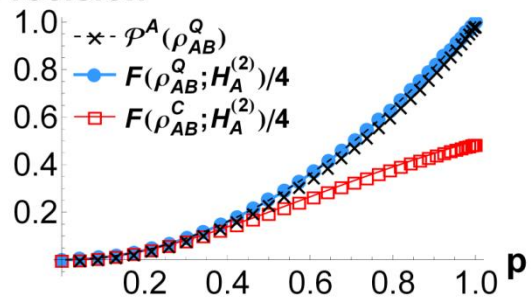

Var($\tilde{\varphi}$)

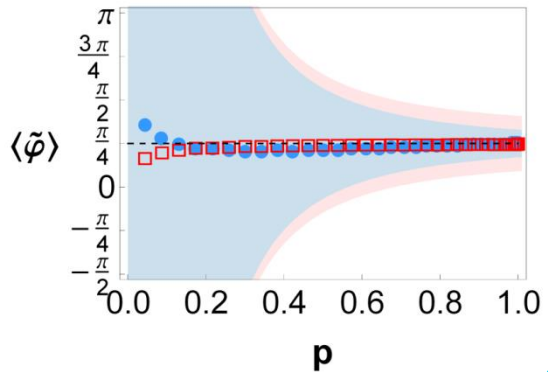
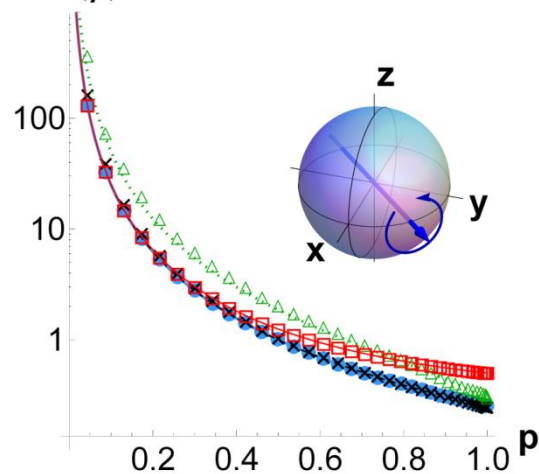

Precision

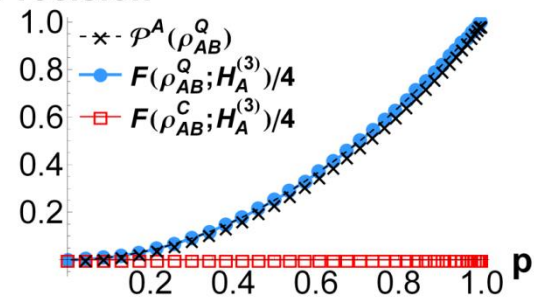

Var($\tilde{\varphi}$)

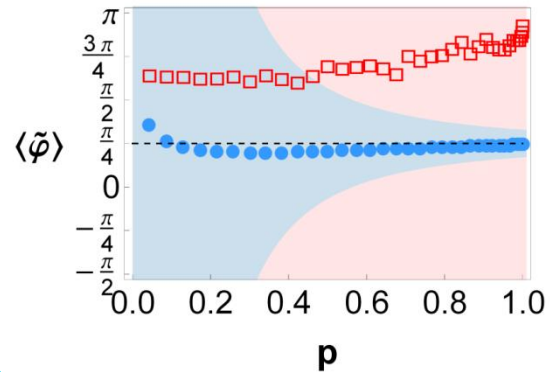
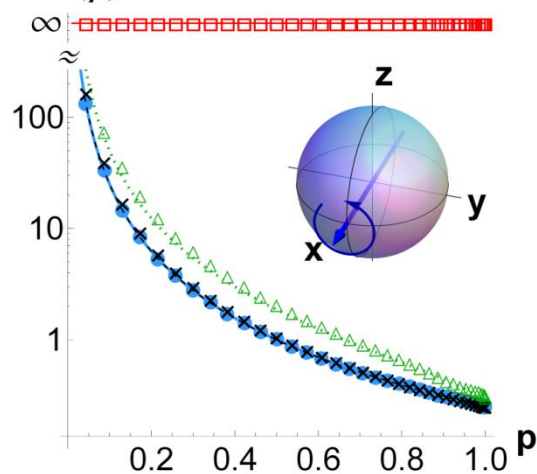

CLASSICAL PROBES CAN FAIL
DISCORDANT ONES
CANNOT

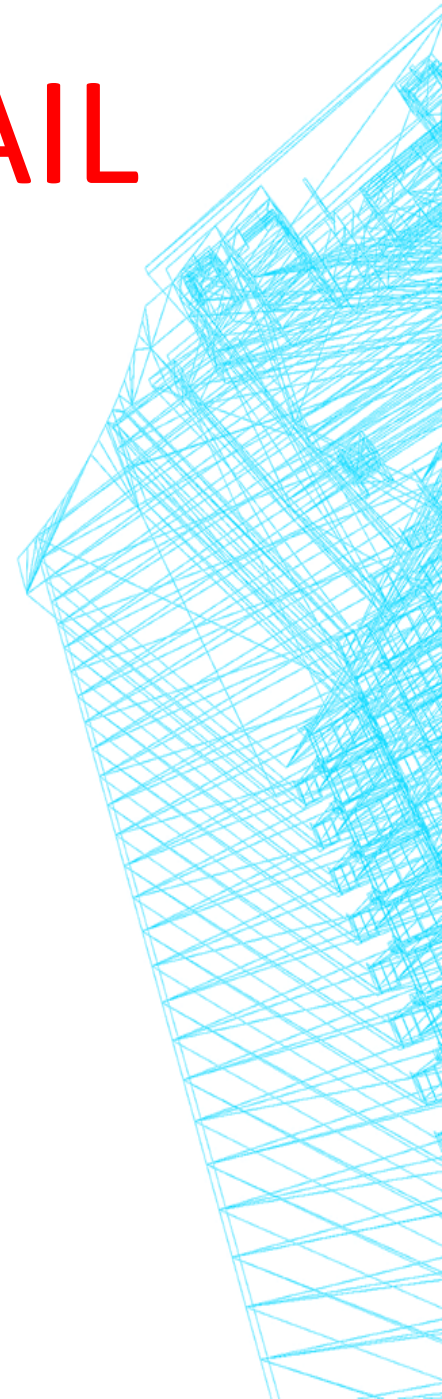

QUANTUM METROLOGY EMBRACED FOR THE WORST RELIES ON QUANTUM DISCORD



<http://quantumcorrelations.weebly.com>

arXiv:1309.1472

FQXi QUANTUM CYBERNETICS

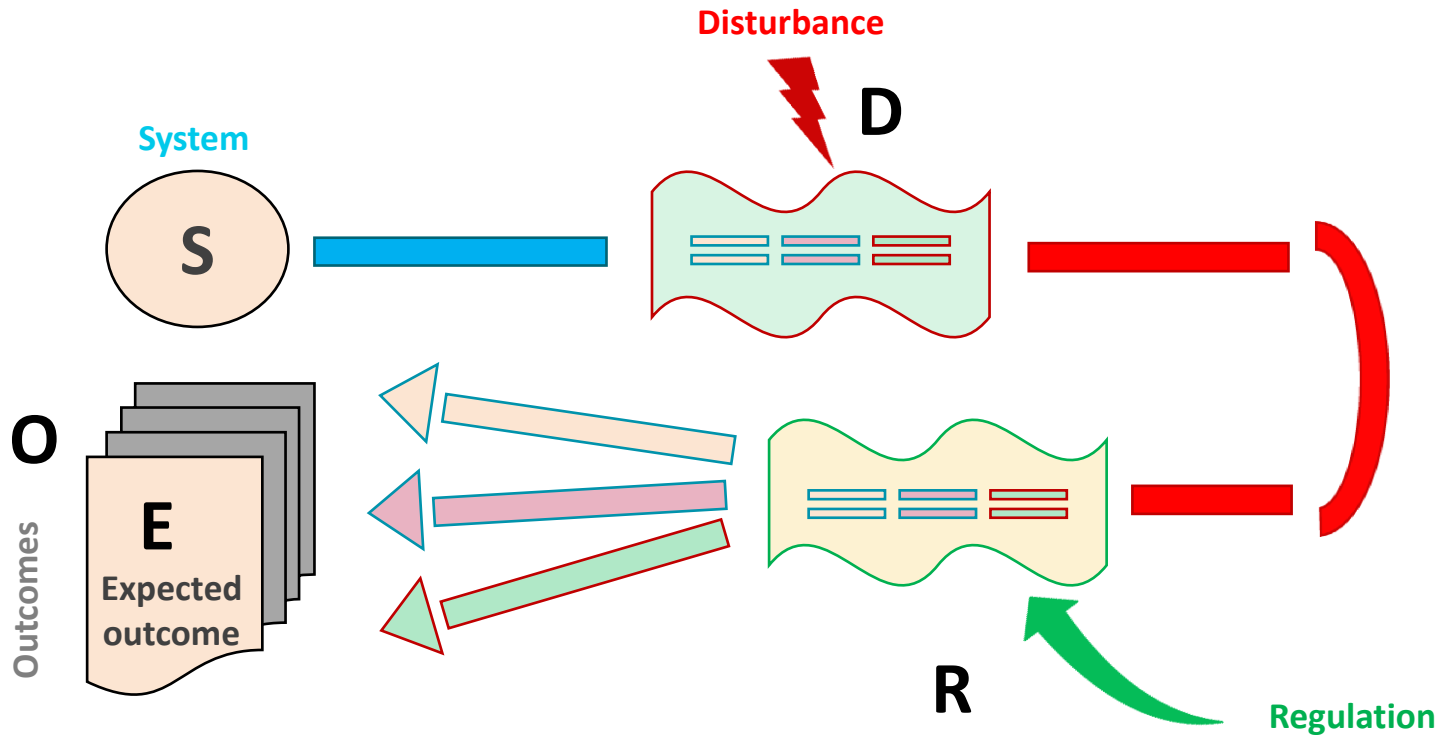

CAN QUANTUMNESS
PROVIDE ENHANCED REGULATIVE
STRATEGIES LEADING TO BETTER
ADAPTATION AND CONTROL?

POSTDOC WANTED

