

Smart Power Electrical Fire Prevention Strip

*By,
Edgar Sanchez,
Kevin Pineda,
Tasfia Reza,
Sahed Saad*



Content *overview*

1

Introduction

2

Comparison and Contrast

3

Technical Description

4

Building: Materials, Cost
& Labor

5

Process of the Innovation

6

Conclusion



Introduction

Smart Power Electrical Fire Prevention Strip

Electrical fires are very dangerous in New York City's older buildings because their original wiring was made before modern electronics.

Traditional power strips are reactive, only responding to huge surges and failing to detect slow, dangerous overheating.

Our Smart Strip uses heat sensors proactively detect issues at the source, that prevents accidents before they ever happen.

Compare & Contrast: Smart Power Fire Prevention Strip

TASFIA REZA



Evolution of Electrical Protection Systems



FUSES
STOP EXCESSIVE CURRENT (EARLY
TECHNOLOGY)

SURGE PROTECTORS
PROTECT FROM VOLTAGE SPIKES
GFCI & AFCI
PREVENT SHOCK & DETECT ARC
FAULTS

CIRCUIT BREAKERS
REUSABLE PROTECTION

Limitations of Traditional Devices



Reactive systems (acts after
danger)



Cannot detect slow
overheating



Hidden fire risks remain
undetected



Issues with Modern Devices

- Surge protectors → only voltage spike
- GFCI/AFCI → not portable or user-friendly
- Smart strips → focus on energy, NOT safety
- No real-time heat monitoring
- Energy focus, not safety

OUR INNOVATION

Smart Power Fire Prevention Strip



Real-Time Heat & Current Sensors

AI-Powered "Brain"

Preventative Cutoff Switch

Multi-Color LED Status

Remote Monitoring & Alerts

Technical Description

Smart Power Electrical Fire Prevention Strip

Fire Prevention Purpose

Designed to reduce electrical fire risks before ignitions occurs

- Detects unsafe conditions early
- Monitors strip activity continuously
- Adds protection beyond standard surge strips

Exterior Structure

Maintains the familiar shape of a common power strip

- Grounded outlet ports
- Power/ reset controls
- LED warning indicators
- Fire-resistant outer shell

Internal System

Built with integrated electronics that monitor performance

- PCB control board
- Temperature sensors
- Current monitoring sensors
- Relay shut off switch

Smart Response features

Automatically reacts when hazards are detected

- Overheat detection
- Overload detection
- Automatic power cutoff
- Warning alerts
- Future emergency notifications

Exterior Structure

Strip's Exterior Design

Figure 1. Exterior Concept View of the Smart Power Electrical Fire Prevention Strip

The device maintains the familiar form of a standard power strip while integrating user interface indicators and safety features for monitoring and fire prevention.

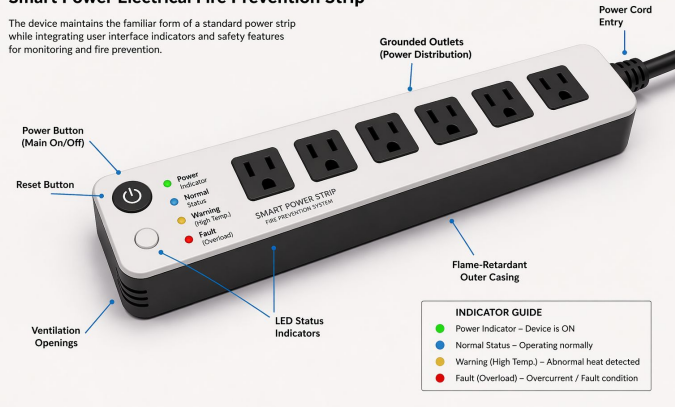

The exterior housing is designed to remain familiar to users while integrating upgraded safety controls, visual indicators, and durable fire-resistant construction for everyday residential and commercial use

Control Interface

- Main power button for operation
- Reset button after shutdown events
- LED indicators show normal, warning, or fault status

Power Access Design

- Multiple grounded outlets for several devices
- Straight-line outlet spacing for easy plug placement
- Reinforced cord entry reduces wear and movement damage

Protective housing

- Fire-retardant outer shell
- Insulated casing protects internal electronics
- Vent openings assist heat dissipation

Internal Layout

Core Components That Power the Safety System

Sensor Network

Temperature and current sensors continuously monitor heat buildup and electrical load throughout the strip

Processing Unit

A microcontroller receives sensor data, compares values to safety thresholds, and determines system response

Protection Hardware

A relay / cutoff switch disconnects power when unsafe conditions are detected, helping prevent failure or fire

Figure 2. Internal Layout of the Smart Power Electrical Fire Prevention Strip

This figure shows the main internal components of the innovation and their physical arrangement inside the housing.

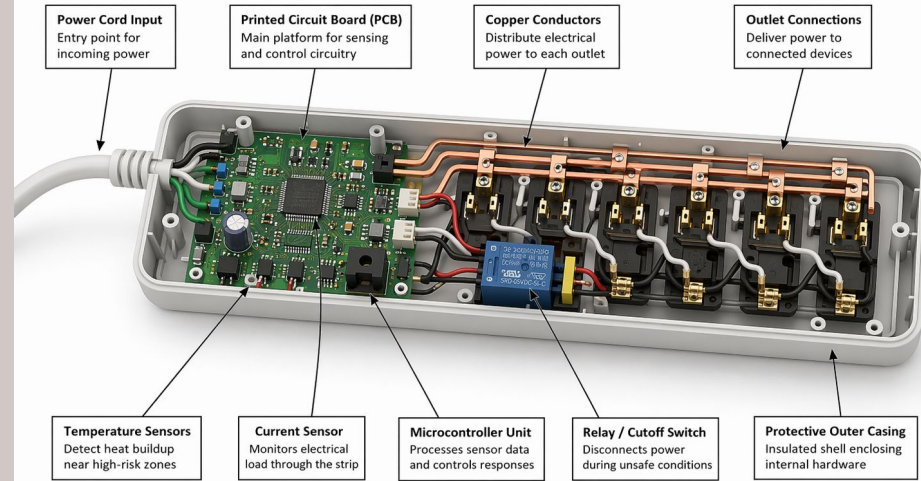

Internal System Summary

The smart Power Strip transforms a standard outlet extender into an integrated safety device by combining sensors, control circuitry, conductive pathways, and automatic shutoff hardware inside one compact enclosure

How it works

Figure 3. Monitoring and Protective Operation of the Smart Power Electrical Fire Prevention Strip

This figure illustrates how the strip monitors thermal and electrical conditions and activates protective responses during unsafe operation.

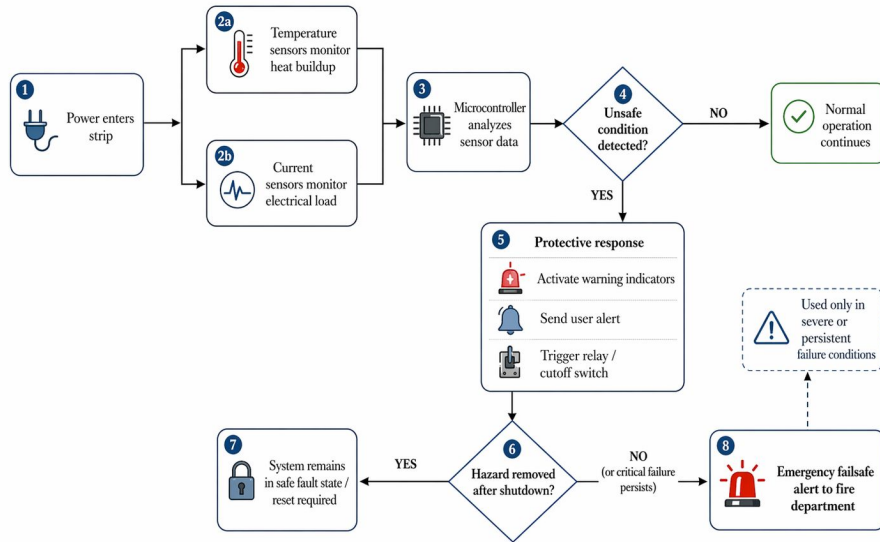

Source: Conceptual operating sequence created for technical description purposes.

Step One: Continuous Monitoring

1

Temperature sensors detect heat build up while current sensors monitor electrical load in real time

Step Two: Smart Analysis

2

The micro controller compares sensor data to preset safety thresholds and identifies unsafe operating conditions

Step Three: Protective Response

3

The strip activates warning lights, shuts off power through a relay, and can issue emergency alerts if risk remains

Core Materials

Copper & Zinc

Heat sensors, made of Copper & zinc, for high thermal sensitivity and response to overheating.

Main Board Chips

Microcontroller chips power the smart detection and alert logic of the strip.



Plastic Protective Shell

Durable plastic casing encases inner cores, providing insulation and physical protection.

i Material selection prioritizes thermal sensitivity and durability, critical for a fire-prevention application in residential environments.

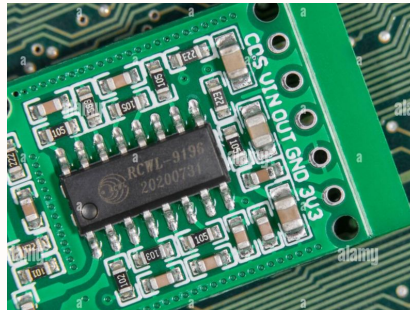

Cost of a Single Unit

\$50

Strip Unit

Manual single-unit manufacturing cost

\$200

Main Panel Box

Local vendor pricing in New York City

\$100

Copper Wiring

Per 100 ft : varies by housing infrastructure

\$60

Hardware & Conduit

Mounting hardware, & fittings

- ❑ **Total Estimated Install Cost: ~\$1,100** : includes materials, wiring, hardware, and labor. Source: Contractor Plus (NYC average).



Installation Cost Varies by Housing Type

Private Home

Direct panel access has lower wiring cost. Easier setup with main panel integration.

Apartment Unit

Central building circuit system = higher cost. Panel may be outside individual unit.

Copper wiring expense is the most variable cost driver. In apartment buildings where the panel box sits in a shared hallway or basement, the complexity, and cost, rises significantly above the \$100/100ft baseline.



Labor & Build Time

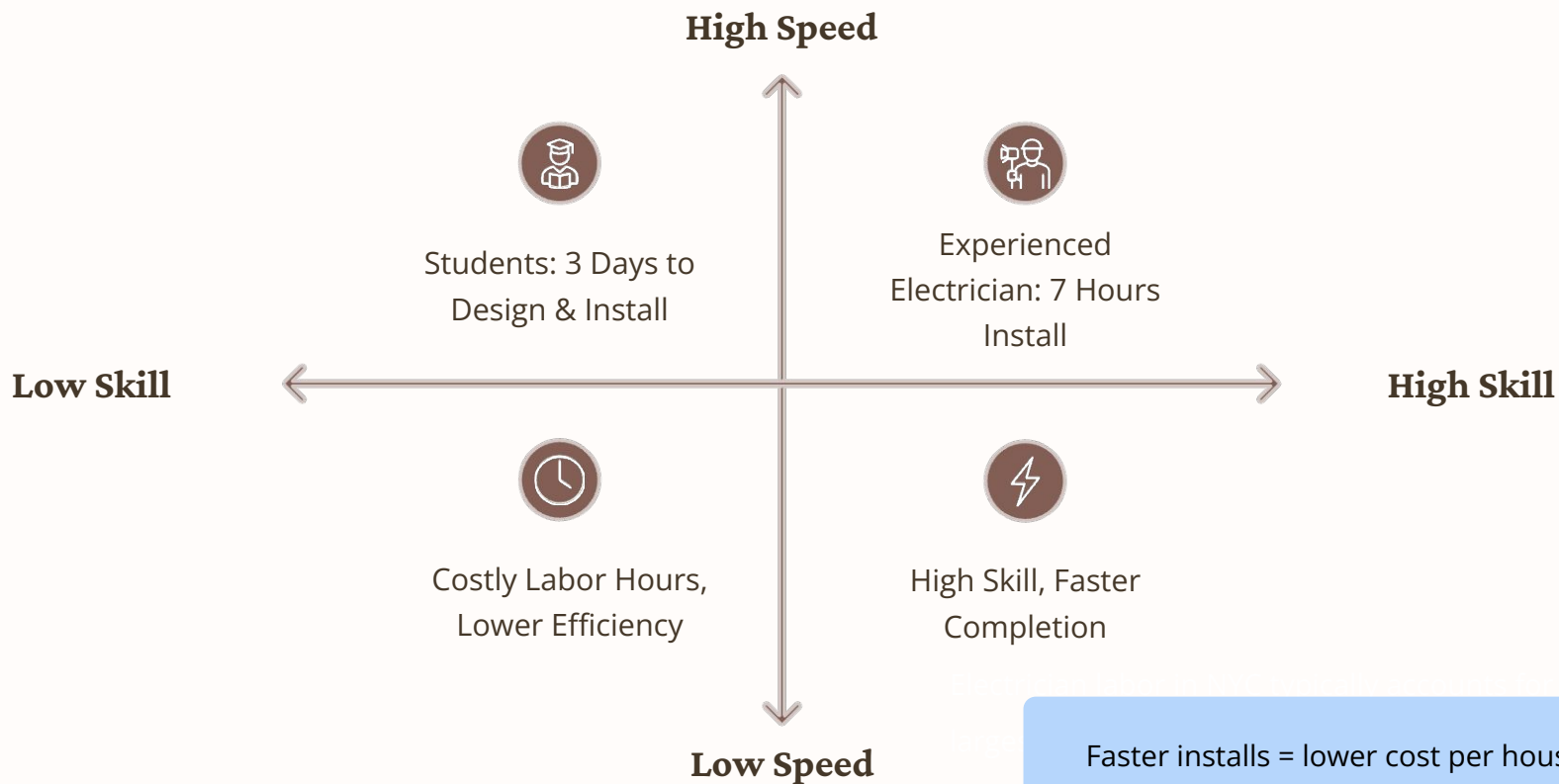

Faster installs = lower cost per household
= wider adoption potential.



Labor Is the Biggest Cost Driver

Breaking Down the \$1,100

- 1 Strip + Board**
~\$50 unit cost
- 2 Panel & Wiring**
~\$300 combined
- 3 Hardware**
~\$60 conduit & fittings
- 4 Labor**
~\$690 remaining — the dominant expense

Labor · 62.73%

Panel Box · 18.18%

Copper Wiring · 9.09%

Strip Unit · 4.55%

Hardware & Conduit · 5.45%

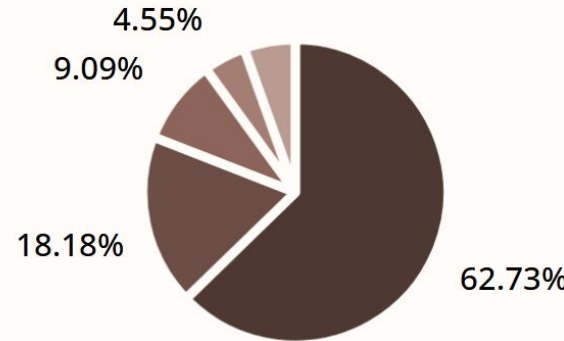

Process of the Innovation

- Sensors monitor current and temperature in real time
- Data is sent to a microcontroller (system brain)
- System analyzes data using safety thresholds
- Detects overheating or abnormal electrical flow
- Triggers warning alert or automatic shutdown
- Uses a relay switch to cut off power instantly

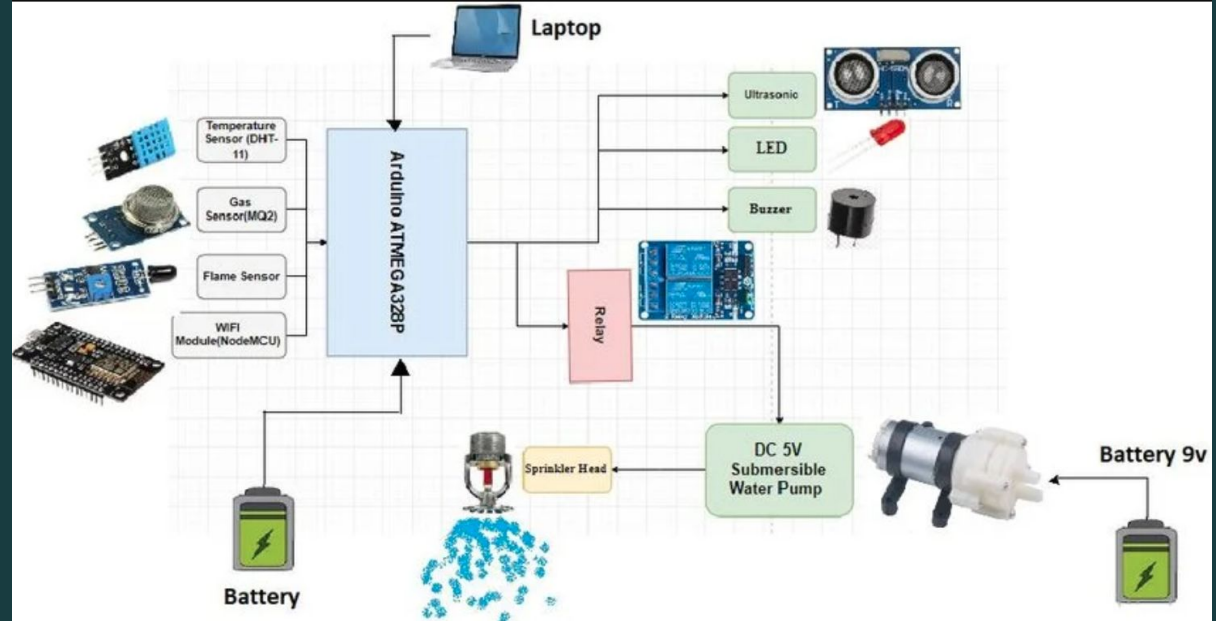

Conclusion

Problem

- Traditional systems are reactive
- Cannot detect slow overheating
- Hidden fire risks remain



Our Solution

- Real-time monitoring system
- Uses sensors + microcontroller
- Detects issues early



How It Works

- Analyzes data continuously
- Identifies unsafe conditions
- Triggers alerts or shutdown



Impact

- Prevents electrical fires
- Safer for homes and buildings
- Real-world engineering solution

