

Editorial

The present Vol. 8, N 1-2 double issue of MTRJ contains three components:

1. Wisdom of Teaching Research first collection of contributions discussing emergence of Aha!Moments in the classrooms among students and teachers. We will accept these contributions for each issue of the Volume 8, and at the end of the year, in the Winter 2016/2017 we will publish their full collection.
2. The Teaching-Research which has four contributions addressing different methods and approaches to the development of mathematical reasoning and its application in “real life”.
3. Reports from the Field with two interesting contributions:
 - A) The report of the NSF supported project from Texas A & M International University informing about increasing female participation in mathematics careers.
 - B) Throw Back Thursday is a new mtrj idea for accomplished mathematics educators to look back upon their thinking in graduate school and offering new comments from their professional experience

Editors of MTRJ are excited to have received four response to the call for the Hunt for Aha!Moments in mathematics classrooms announced recently. We start with the observations of the graduate student at the Teachers’ College, Bukurie Gjoci, who had experienced Aha!Moment as a teacher of remedial mathematics in a community college. She introduced a new approach to Word Problem Solving, which had turned the class on its head. To every problem situation she asked “What if it was you?” (in this situation). It is known that the personalization of a mathematical situation eases students into appreciation of the subject (Prabhu, 2016) and Bukurie Gjoci method is a next confirmation of that knowledge. The contribution by Brian Evans describes facilitation of Aha!Moments among student-teachers with the subsequent analysis of the components that led to such a moment of understand. This analysis, an example of which is Koestler’s based bisociative framework with its hidden analogies, is critical to enable teachers’ design of instruction which may lead to Aha!Moment. Hannes Stoppel, on the other hand, analyzes his students’ views on the role of creativity in problem solving. He demonstrates that students’ understanding of creativity depends on the type of problem they are engaged to solve.

The last paper in the series of Aha!Moments looks upon this phenomenon through the physiological angle by observing problem solver’s eye movements. The method can be quite good in precisely determining the timing of the Aha!Moment.

The Teaching-Research collection of reports focuses on the development of mathematical reasoning in different context and its impact upon reasoning in “real life”. Freiman and Applebaum report the high level of student engagement in mathematics in the context of

strategy games. In particular they are interested in Bachet games, different versions of which are quite popular. They ask a standard Teaching-Research question:

- A) What is effective methodology to introduce students to the strategy game?
- B) What are the student methods of reasoning emerging during the implementation of A).

Dieter Shott, on the other hand investigates the transfer of reasoning from mathematics into every day's life to "expose dubious arguments and interests". His arguments lead to modelling of "real life" situations easing us into the theme of the next paper by Klymchuk and Javonoski, who are interested in the methods of student argumentations in the context of ballistic models.

The section culminates with Murray Black's describing the knowledge assessment among the New Zealand State employees.

The Reports from the Field contain the report on the NSF-based project in Texas A&M. The interest of Goonatilake et al is in addressing the female participation in mathematics. They assert they have the approach but its successful implementation requires strong political will. The last short report of Doyle compares her contemporary experience with her own thinking as a graduate student of Teachers' College. An important question which emerges from Doyle's Throw Back is the role of Discovery method in teaching, especially in teaching remedial mathematics. We hope to come back to this question in the near future in mTRJ on line.

List of Contents

Volume 8 **Wisdom of Teaching Research: Creativity of Aha! Moments**

- What if it were you?.....*Bukurie Gjoci*
- Breakthrough Moments in Problem Solving.....*Brian Evans*
- Creativity ≠ Creativity.....*Hannes Stoppe*
- Phases of a ten-year old student's solution process of an insight problem as revealed by eye-tracking methodology..... *Csaba Csicos and Janos Steklas*

Teaching Research

- Engaging elementary school students in mathematical reasoning using investigations: Example of a Bachet strategy game..... *Victor Freiman and Mark Applebaum*
- Mathematical Curriculum, Mathematical Competences and Critical Thinking.....*Dieter Scott*
- Analysing University Students' Abilities in Making Assumptions in a Ballistics Model: A Case Study.....*Sergiy Klymchuk and Zlatko Jovanosky*
- Teaching and Assessment of Statistics to Employees in the NZ State Sector.....*Murray Black*

Reports from the Field

- Improving Gender Disparity in Scholarship Programs for Secondary-Level Mathematics Teachers...*Rohitha Goonatilake, Katie D. Lewis, Runchang Lin, and Celeste E. Kidd*
- Throwback Thursday.....*Kathleen Doyle*



What if it were you?

Bukurie Gjoci

Teachers College – Columbia University
gjocibukurie67@gmail.com

Abstract

Teaching Developmental Mathematics Courses to Community College students for more than seven years in New York City has given me the opportunity of experiencing many Aha! moments in my classrooms, one of which I will describe here. One of the beautiful and, at the same time challenging to teach, was: How to Solve Word Problems. What added to the challenge was the fact that the students were not willing to even try to learn how to solve those problems. They would tell me: This is so hard, I can't do it. I hate mathematics, that's why I am at the remedial math level. In this paper I explain how I was able to gain their attention and their willingness to learn, and, even like Mathematics.

Introduction

Since the Community Colleges today do far more than offer a ladder to the final years, and everybody is welcome, the students there come from diverse backgrounds. A well-fitted description of Community College is given in the title of the New York Times' article, By John Merrow, *COMMUNITY COLLEGE; Dream Catchers*. By writing the

story of four different students and the dreams they are chasing, he reveals the background of most of community college students. More than one third of the students indicated that *changing careers* was the major reason they were taking classes, some were *lifelong learners*, and some were part of *a harsh reality*, needing to take remedial courses several times. There were some that were doing *a smart transfer*, saving money. And since most of the students entering Community Colleges are not ready for college level courses, specially in Mathematics and English, he points out that Community Colleges are charged with doing the heavy remedial lifting, and they are now as much 10th and 11th grade as 13th and 14th.

I am trying versus I am getting things done.

Most of my students in developmental courses came from *a harsh reality* background. They went through High School with the idea that mathematics is a not understandable subject for most of the students. The first day of class I asked them to introduce themselves and tell us their major, and why they chose that particular major. I got answers like: *My name is Chris, and the major I chose is Social Services, because I want to make a difference in my community. I'm Janet, and I want to be a nurse, since that will give me a stable financial life. I'm Oscania, I'm studying Psychology because it has the least required mat*, etc. Enjoying their answers, I could read the dreams they were chasing on their faces covered by a fragile confidentiality. In my class were sitting the people with dreams that in a near future will change the world, and still they were scared of math. They were going to college, so they had done the first step toward reaching their dreams, and I felt it was my job to increase their confidentiality, and give them comfort that the math class will be doable and enjoyable. While going through the syllabus, I tried to convince them it will not be hard, and that they must believe on themselves and be willing to do the work. As the semester was going on, while checking their work, I could tell that some of them were just not working enough. When I asked them the question:

What was unclear that kept you from finishing this exercise?, most of the answers were: *But..., Miss..., I am trying...!* At that point I made it clear that there is a big difference between *trying* and *getting things done* and that the mentality that *if you at least try, you will be ok* will not help them succeed in life. I consistently reminded them about the help resources they can use to go from *trying* to *getting things done*, at least in the math class. I wanted them to understand and believe that if they put their attention on what they are doing and being willing to do the work, they will get things done.

I even read the poem *Don't quit* to them:

When things go wrong, as they sometimes will ... Rest if you must, but don't quit.

What if it was you?

When I introduced the topic How to Solve Word Problem, I tried my best to explain the procedure they needed to follow to solve them. The procedure I use came from an online discussion group I was a member of Elementary Algebra instructors at Bronx Community College, led by Anthony McInerney, Assistant Professor & Chair, during Fall semester 2010. When teaching word problems we are teaching the problem of *translation* from one language, English, to Mathematics. And for most serious translations, the necessary tool is a dictionary. Even someone fluent in both languages occasionally needs to refer to one. So, the *English-Math Dictionary* is a very important part of the following procedure, by which one can consistently present the word problems in a step-by-step way:

1. Read the problem entirely and get a feel for the whole problem.
2. Make a *Dictionary*, which lists all unknown quantities and their units of measure in English and their algebraic translation next to it.
3. Translate the wording into algebraic expressions, and then combine them into an equation, equations, or inequality (rarely).
4. Solve the equation/equations.

5. Answer the question, which involves going back to the Dictionary and substituting, as well as discarding extraneous solutions (for example, negative numbers representing the length of a side of a triangle).

When outlining this methodology on the board, I emphasize: the only MATHEMATICAL step is the forth step. The others are translation steps. Using this procedure brings interesting discussions on one-variable versus two-variable approaches to problems. Using one variable to solve problems with more than one unknown quantity involves more effort in building an appropriate *Dictionary*, writing one unknown in terms of the other, and solving a single equation in one unknown, whereas using two variables makes the *dictionary* step easier, but involves solving a system of equations.

It was the second class we were working on *How to solve word problems*. Even though, I thought the students were appreciating the step-by-step way, not all were willing to master it.

I asked my students to work on the following problem:

Two buses leave Port Authority at 12 at noon. One bus travels east at 50 mph and the other travels west at 45 mph. What time is it when the buses are 451.25 miles apart?

As I was waiting for them to work on their own, I walked around and I realized that that not everybody was working. When I asked them why, some of them answered:

This is so hard, I can't do it. I hate mathematics, that's why I am at the remedial math level.

No one was able to answer it. Then I asked them what if it was you and your friend driving toward each other? It is 12noon, you are 365 miles away from each other, you are driving with 45mph and she is driving with 60mph. What time are you going to meet?

And ... this was the time when the Aha! Moment took place.

One of the students said, *In this case I can find it out without using math.*

I asked him to come and explain his *non-math* way on the board for everybody.

He started by drawing a picture describing the situation as follows:

After an hour, at 1pm, we will be apart 105 miles less than at noon, at 2pm we will be 210 miles closer, and after three hours, at 3pm we will be only 35 miles apart. So we will end up meeting around 3:30pm. When I asked for the exact time one of the students answered: at 3:20pm. I asked her to explain why, another one said because in 20 minutes, he, (referring to the student in front of class), will do 15 miles and she will do 20 miles. At that moment I realized that the question: *What if it was you?* was magical; everybody in class was involved, paying attention, and trying to figure out other word problems. I asked the students why did he call his way of solving the problem *non-mathematical* he answered *because there is no equation involved*. Spending that class time matching *their way* with the *mathematical* one, and showing them that the equations are just mathematical translations of English statements made the students able to follow the procedure without memorizing it. They were able to *Read the Math* they were using, leading to creating the *Dictionary*. The fact that he started by finding out how much the distance will be shortened in *one* hour, and what we need to know is the time they need to travel to meet, x - the amount of time in hours needed to travel in order to meet, and the equation $110 \text{ miles/hour} * x \text{ hours} = 365 \text{ miles}$.

We solved it and ...*Aha!*... we got the same answer, taking care of converting the decimal expression of the time into a sixty-minute system. Everybody understood what was going on. It was not hard for them to write an equation to solve the previous problem. They were able to follow the procedure without memorizing it.

The way we solved that problem helped me gain their attention, and their willingness to learn the mathematics hidden behind their intuitive reasoning. Through the years I have been lecturing by using the question *What if it were you?* in real life situations, which always resulted in more student involvement and attention. Mastering the information through a question-and-answer process helps leading the students in the proper direction to reach correct conclusions without always providing the answers. Challenging them by presenting materials and constructing assignments in a way that



MATHEMATICS TEACHING-RESEARCH JOURNAL ONLINE
VOL 8, N 1-2
Fall and Winter 2015/16

engages students to apply their knowledge in new learning situations allows them to share the excitement of discovery.

References

McInerney, Andrew, (2010). Solving Word Problems, [*mth05discussion@googlegroups.com*].

Merrow, John, (2007). COMMUNITY COLLEGE; Dream Catchers, *New York Times*.

Retrieved from
<http://www.nytimes.com/2007/04/22/education/edlife/merrow.html>

BREAKTHROUGH MOMENTS in PROBLEM SOLVING

Brian R. Evans

Pace University, New York, United States

bevans@pace.edu

Abstract

Problem solving is critically important learning goal of mathematics as well as a necessary process for teaching mathematics. One of the most important moments of problem solving is when the student makes a cognitive breakthrough, also called an “aha!” moment, in the learning process. Teachers can serve an important role in scaffolding students to reach these moments of insight during the problem solving process. This article provides an example of the author’s experience with “aha!” moments in his own mathematics education classroom with preservice and in-service teachers.

Introduction

Problem solving is critically important learning goal of mathematics as well as a necessary process for teaching mathematics (National Council of Teachers of Mathematics [NCTM], 2000; Posamentier & Krulik, 2008; Posamentier, Smith, & Stepelman, 2008). It is one of the NCTM’s five process standards (NCTM, 2000), and has been considered by the National Council of Supervisors of Mathematics (NCSM) as the main reason for studying mathematics (NCSM, 1978). The NCTM (2000) considers problem solving to be a goal for learning mathematics in addition to being a means to do so. One of the most important moments of problem solving is when the student makes a cognitive breakthrough, also called an “aha!” moment, in the learning process. Teachers can serve an important role in scaffolding students to reach these moments of insight

during the problem solving process. This article provides an example of the author's experience with "aha!" moments in his own mathematics education classroom with preservice and in-service teachers.

Conceptual Framework

There are three areas of work supporting the premise of this article: 1) Research in problem solving; 2) Vygotskian social learning, scaffolding, and Zone of Proximal Development (ZPD); and 3) bisociative framework.

Problem solving is a process in which an individual uses previously acquired knowledge, skills, and understanding to satisfy the demands of an unfamiliar situation (Krulik & Rudnick, 1989). George Polya (1945) outlined the process for attempting to solve an unfamiliar problem: 1) Understanding the problem; 2) making a plan; 3) carrying out the plan; and 4) looking back. Problem solving can be considered the foundation of critical thinking and inquiry learning in a mathematics classroom, and it has been recommended that mathematics be taught from a problem solving perspective (Clark, 1997; Schoenfeld, 1985). The work of the NCTM, Clark, and Schoenfeld form a conceptual framework for the teaching and learning of problem solving.

Vygotsky is well-known for his theory that students learn best through social interactions and that teacher can provide the optimal amount of support, or scaffolding, for the learning process (Vygotsky, 1978). Learning through social interactions often is manifested in the classroom through the use of collaborative group learning in which students work together to solve a problem. Scaffolding "refers to the specific strategies or structures that help people move along in their development" and have been called "intellectual supports needed to reach new levels of understanding" (Nakkula & Toshalis, 2006, p. 10). Vygotsky called this the Zone of Proximal Development (ZPD), which "refers to the relative level of one's development in particular areas and is expressed as the difference between what a child can do without guidance and what he or she can do with assistance" (Nakkula & Toshalis, 2006, p. 10).

Bisociation is “a spontaneous flash of insight, which...connects the previously unconnected frames of reference and makes us experience reality at several planes at once” (Koestler, p. 45), which can be considered the “aha!” moment often experienced in a classroom. Bisociation is the antithesis of the Einstellung effect and is a foundation for creativity, inquiry, and discovery. The Einstellung effect is the habits people form in solving problems that keep them trying the same tested methods repeatedly rather than approach the problems from new and innovative perspectives. Bisociation is closely connected to the “aha!” moment students achieve during the problem solving process in a mathematics classroom (Czarnocha, Baker, Dias, & Prabhu, 2011). The foundation of this article and the process involved in problem solving is a the bisociative framework.

Teacher Education and Problem Solving

The author of this article teaches preservice and in-service teachers in a mathematics methods course at Pace University in New York. The teachers in his class are studying to become elementary school teachers and are required to take a class in mathematics pedagogy. The class is based on the NCTM *Standards* and Common Core, and is a reformed- and research-based class that addresses problem solving, conceptual mathematics understanding, and pedagogy. At the beginning of each class the author gives the teachers a “Do Now” problem that involves confronting an unfamiliar mathematics situation in which the teachers have the opportunity to work in collaborative groups to solve the problems. The class meets for 14 evenings through the fall semester each year, and the teachers solve 13 mathematics problems of this type at the beginning of every class except the first class.

The author first presents the problem to the class on an LCD projector and then allows the teachers time to read through the problem and begin to brainstorm the methods to solve the problem. Next, the teachers self-select to form their own groups in which they can discuss the problem and begin working together to solve the problem. After sufficient time has been given, the professor begins the scaffolding process by asking the right questions at the right time such as the following.

- 1) What information does the problem provide to you?
- 2) What information do you need?
- 3) What question are you trying to answer?
- 4) What methods do you have that might work in this situation?
- 5) Have you considered the problem from this particular angle?

While the teachers are working on the problem the professor is walking around the class to provide individual and group support when needed. It is during this process that teachers often raise their hands with excitement and call the professor over to explain their reasoning and solution. It is during this moment that teachers experience the “aha!” moment associated with the bisociative framework. In some cases, the teachers have a mistake in their process or reasoning, and have to return to the problem. In other cases, the correct solution had been found through correct reasoning. In cases in which the correct answers have been found, the professor follows up with a new set of questions, such as 1) What if the conditions were different?; 2) Can you generalize your solution?; and 3) Could you approach the problem differently with another method of solution?

Students are assessed based upon the professor’s observation of the teachers’ reasoning in the problem solving process. Additionally, selected teachers share their solutions with the class at the end of the session. Teachers also keep two reflective journals in the class. The first is a reflection on what they had learned with emphasis on the problem solving process. Secondly, teachers keep journals on what they observe in their own field observations in elementary school classrooms, which focuses on the application of problem solving in a classroom setting. Teachers express through own reasoning in the problem solving process along with the variables that led to the “aha!” moment for them. There are multiple goals for this process. First, teachers experience the problem solving process as simulation of the process their own students experience in the classroom. This helps teachers better scaffold the problem solving process for their own students. Second, teachers have the opportunity to reflect on their own problem solving and improve upon it. Third, teachers examine the variables that lead to the “aha!”

moment to refine their own thinking and improve their own problem solving. Fourth, teachers have the opportunity to reflect upon improving the conditions that lead to the “aha!” moment for their own students in their own classrooms.

Teachers have expressed an appreciation for the problem solving exercises even if they initially encountered frustration in the process. Teachers have indicated that beginning each class with a problem solving exercise helped them to incorporate problem solving within their own classrooms and better understand both their own and their students’ reasoning and thinking.

Reflection and Conclusion

This process at the beginning of each class rests upon a pedagogical problem solving foundation using Vygotsky’s social learning, scaffolding, and Zone of Proximal Development (ZPD) along with Koestler’s bisociative framework. The combinations of these frameworks provide teachers and students with opportunities to “think about thinking” in their own problem solving processes. Being a reflective practitioner is important for quality teaching just as being a reflective problem solver is important for being a good problem solver. The reflective process in relation to teaching and problem solving helps shape better mathematics teachers for the classroom.

References

- Clark, D. M. (1997). The changing role of the mathematics teacher. *Journal for Research in Mathematics Education*, 28(3), 278-308.
- Czarnocha, B., Baker, W., Dias, O., & Prabhu, V. (2011). Teaching-research guide to problem solving. *Mathematics Teaching-Research Journal*, 5(3), 1-114.
- Koestler, A. (1964). *The act of creation*. New York, NY: Macmillian Publishers.
- Krulik, S., & Rudnick, J. A. (1989). *Problem solving*. Boston, MA: Allyn and Bacon.
- Nakkula, M. J., & Toshalis, E. (2006). *Understanding youth: Adolescent development for educators*. Cambridge, MA: Harvard Education Press.



MATHEMATICS TEACHING-RESEARCH JOURNAL ONLINE
VOL 8, N 1-2
Fall and Winter 2015/16

National Council of Supervisors of Mathematics. (1978). Position paper on basic mathematical skills. *Mathematics Teacher*, 71(2), 147-152.

National Council of Teachers of Mathematics. (2000). *Principles and standards for school mathematics*. Reston, VA: National Council of Teachers of Mathematics.

Polya, G. (1945). *How to solve it*. Princeton, NJ: Princeton University Press.

Posamentier, A. S., & Krulik, S. (2008). *Problem-solving strategies for efficient and elegant solutions grades 6-12*. Thousand Oakes, CA: Corwin Press.

Posamentier, A. S., Smith, B. S., & Stepelman, J. (2008) *Teaching secondary mathematics: Teaching and enrichment units* (8th ed.). Boston, MA: Allyn & Bacon.

Schoenfeld, A. (1985). *Mathematical problem solving*. New York, NY: Academic Press.

Vygotsky, L. S. (1978). *Mind in society: The development of higher psychological processes*. Cambridge, MA: Harvard University Press.

CREATIVITY \neq CREATIVITY

Hannes Stoppel

Westfälische Wilhelms-Universität Münster

Aha! Moments might have a big effect on the motivation of students. A cause might be their perception of creativity which often is demanded in mathematics lessons. As appeared with the study of students of grade 12 and 13 the understanding of creativity might be divided into two different classes in connection with extension of knowledge and the application already familiar contains concerning the topic. During student's projects differences appeared in whether foreknowledge of students was used to attain solutions and applied to the projects or they became acquainted with some new topics to apply it to their project. Connections appeared between different student's perception of creativity and the elaboration to their projects and lead to Aha! Moments.

INTRODUCTION

Everybody got a certain imagination of creativity. In literature might be found a lot of different perceptions of creativity exist. Wallace (1926) defined creativity based on the Gestalt theories by (i) *preparation*, (ii) *incubation*, (iii) *intimation*, (iv) *illumination* and (v) *verification*. On the other hand Wallas & Kogan (1965) gave another definition of creativity by (i) *originality*, (ii) *fluency*, (iii) *flexibility* and (iv) *elaboration*. In Torrance's test of creative thinking with words creativity (Torrance, 1974) is given by *fluency*, *flexibility*, *originality* and *elaboration*.

In accordance to Torrance (1974) and Silver (1997) in Leikin (2009) the measurement of creativity in solutions of mathematics exercises is divided in *fluency*, *flexibility*, *total creativity* and *final creativity*, which got a scaling for specific exercises.

As is displayed, no single, authoritative perspective of definition of creativity exists (Mann, 2006; Sriraman, 2005; Kattou et al., 2011; Nadjafikhah, Yaftian & Bakhshalizadeh, 2012).

The professional literature distinguishes sometimes between *creativity* and *mathematical creativity*. In Liljedahl & Sriraman (2006) a definition of professional level mathematical creativity is given by (p. 18)

- (i) the ability to produce original work that significantly extends the body of knowledge (which could also include significant syntheses and extensions of known ideas)
- (ii) opens up avenues of new questions for other mathematicians.

Creativity at the school levels are (p. 19)

- (iii) the process that results in unusual (novel) and/or insightful solution(s) to a given problem or analogous problems, and/or
- (iv) the formulation of new questions and/or possibilities that allow an old problem to be regarded from a new angle.

Connections between Aha!Moments exist (Liljedahl, (2004; Liljedahl, 2005). Thus Aha!Moments might be influenced by connections between creativity and different phases of projects. Therefore different opinions of students about creativity of Aha!Moments may appear due to different relationships with the procedure of their projects. Aha!Moments of distinct types might lead to increased motivation anyway. Previous studies concerning creativity did not regard the opinion of students about creativity. Furthermore, up to now no investigation of relationships between students' opinion about creativity in relationship to teaching sequences or projects exist. The coherence between the two is the focus of this article. Therefore we consider the results of students' projects and their description of creativity contained in videos.

STRUCTURE OF COURSES

According to the Conference of the Ministers of Education of the Länder in the Federal Republic of Germany (Kultusministerkonferenz, 2013), students can improve their ability to study with help of a "special learning performance" (*besondere Lernleistung*). As response, some of the federal states designed special courses for the last three years before graduation. In North Rhine-Westphalia (NRW) those project courses started in the school year 2011/2012 and take place for a year during the last two years before graduation (*Abitur*, Ministry of Education in NRW, 2010). By the Ministry of Education in NRW, students should have the possibility to study autonomously and cooperatively in connection with projects and applications as well as in interdisciplinary contexts.

Because of shortage of mathematics teachers¹, a lot of schools were unable to establish project courses. Hereby so inspired, the Institute of Mathematics and Computer Science at the University of Münster together with the Institute of Education of Mathematics and Computer Science established project courses of different topics.

The author taught two courses of the topic of *coding and cryptography* in each of the school years 2013/2014 and 2014/2015. In the school year 2013/2014 the courses started with an introduction to mathematical foundations as numbers, groups, rings and fields, matrices, basics of topology, plane algebraic curves, probability and different algorithms. The foundations were set within the course's lessons, and the students had to study autonomously mathematical and application-oriented backgrounds between the classes (fig 1). Thus, during the school year 2014/2015 the students started with short projects

¹ These shortages appear besides mathematics in all sciences and computer science.

over coding including mathematical contents instead of the introduction to mathematical foundation. Results were presented by each student at the end of every project.

After the phases of introduction to mathematical foundations or short projects, the students were encouraged to look for topics for projects on coding. In case they were unable to find topics themselves, the teacher suggested topics. With one exception, all students were unable to find topics themselves and accepted suggestions by the teacher. After choosing topics the students started to elaborate their projects for two months and prepared their presentations. Except one group of two members, all of the students worked alone. Later they collected their results alone by pairs.

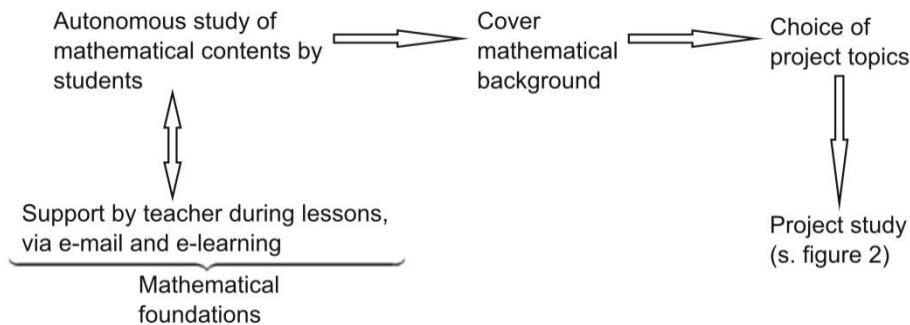

FIG. 1. PHASES OF THE COURSE IN THE FIRST QUARTER OF THE SCHOOL YEAR.

The students began to process their projects in a way which might be described by cycles. At the beginning they studied the topics autonomously. During the time of four up to six weeks they had to study their topics. All this time the students were offered support by the teacher via e-mail or by e-learning and were given hints concerning the literature as well as copied material. In the end they were expected to prepare a presentation. Afterwards they presented the results of their work to the class, followed by a short discussion including improvement suggestions by the other students and the teacher. The students extended their projects afterwards, see figure 2.

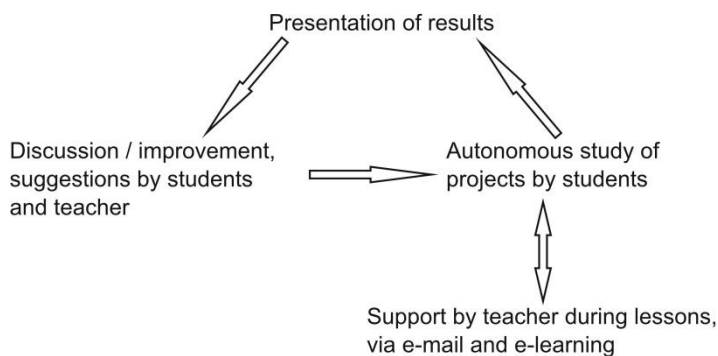

FIG. 2. CYCLE OF PROJECT STUDY.

Five months after the beginning of the school year the students presented the final results of their projects for about 15 minutes each. Because the mathematical foundations in the beginning of the school year included the principles of all topics, the students were able to understand the mathematical contents of the presentations.

The next phase of lessons began with an introduction to cryptography by lectures of the teacher. Afterwards the students worked on another two projects phased analogous to project 1 and shown in figures 1 and 2. The topics of projects might be have been connected, e.g. the project 2 *cryptography with elliptic curves* and project 3 *public key in relationship with elliptic curves*. The execution of each project took two months. The school year finished immediately after the presentation of the last projects.

METHODS

The assessment includes qualitative and quantitative elements which are aligned by isomorphic transformation following Mixed Methods. Quantitative data were taken at five different moments all over the school year with identical questionnaires. Furthermore in the middle and at the end of the school year semi-structured interviews were taken. The moments of the data collections were taken in connection with changes of topics of the courses over the whole year, see figure 3.

The author considered the questionnaires and created the semi-structured interviews based on observation at the first questionnaires. Because the courses were taught by the author, different people conducted the interviews. The author assured his students that he would not listen to the interviews until the end of the school year.

The students kept research notebooks and learning diaries in one folder. The parallel structure of these parts of the folder allowed for interconnections between research notes and diary texts. At the end of the school year the author made copies of them.

As mentioned above the students presented their preliminary and final results of their projects. The final presentations of each project included a summary of contents for all the other students. The author took copies from every presentation and all summaries.

The analysis of data is based on interviews, questionnaires, notebooks, learning diaries, presentation and summaries of students. For triangulation of questionnaires and interviews several parts of the interviews were transformed from qualitative to quantitative form after transcription.

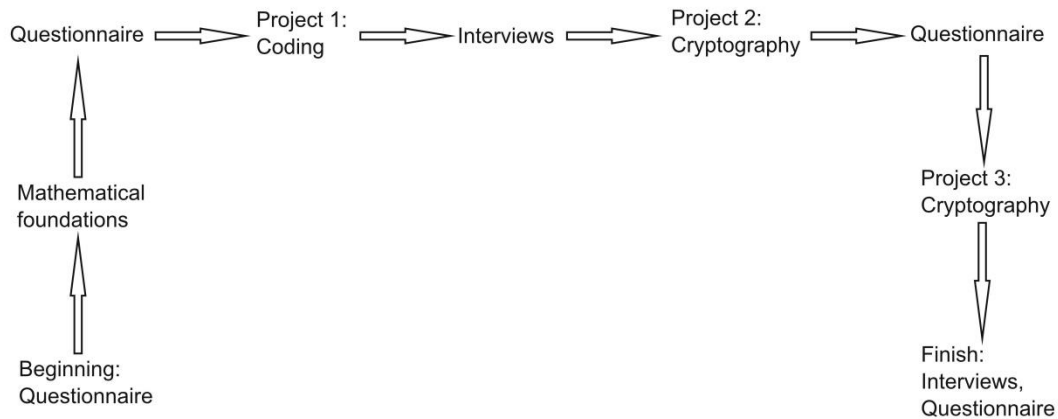

FIG. 3. DATA COLLECTION DURING THE STUDY.

DATA COLLECTION AND PROGRESSION OF THE COURSES

Over the school year all students filled out four questionnaires and gave two interviews. The questionnaires are created based on Schommer-Aikins et al. (2000) and Urhahne and Hopf (2004) concerning epistemological beliefs, additional aspects of beliefs related to mathematics (from now on denoted as *mathematical beliefs*) based on Kloosterman and Stage (1992). All the questionnaires used over the year were the same.

The interviews covered *knowledge and understanding of educational contents, perception of mathematical contents, association of mathematics and its implementation* and attitudes about statements concerning mathematics: *logical nature, empirical nature, creativity and imagination, discovered vs. invented, socio-cultural aspects, scientific aspects* (Liu & Liu, 2011). The answers are categorized by *mathematical understanding, opinion about mathematical background, definition of mathematics, application of mathematics in society and meaning of mathematics for nature*.

Moreover, the first interviews started with a narrative part concerning the contents of the courses, where students were asked to give a description of the mathematical foundations of the course and their own projects as well as projects by other students. The second interviews differed from the first ones in the narrative part about the contents of the course. Students were required to describe contents of their own projects and projects of the other students from all over the school year, not only about the second half.

The interviews were taken by colleagues of the author, the questionnaires were distributed and collected by himself. The first interviews were recorded with 35 students. The second interviews were conducted with only 27, as some of the students did not appear. With 39 students at least one interview was recorded.

At the beginning of the first lesson the students filled in questionnaires. Then the course started with an introduction to coding and cryptography including lectures and exercises over four lessons followed by the treatment of mathematical foundations useful for the

prospective contains of the course for more than three months. The second questionnaires were filled in at the end of the phase of mathematical foundations for students' projects. Immediately afterwards the students started their first projects about coding and processed them for about two months.

After the presentation of final results of students' first projects semi-structured interviews were conducted. Subsequent to the interviews an introduction in cryptography started followed by students' first projects about cryptography. At the end of the next quarter of the school year the students presented the results of their projects. Immediately after the presentations the students filled in the third questionnaires.

Afterwards the students started the last projects of the course and presented results about two months later. Immediately after the presentation of results students gave the second interviews and then completed the fourth questionnaires in the last lesson of the school year.

RESULTS

The interviews of all the 39 students are used for this investigation. If the second interview exists it was taken for the study. If only the first interview exists this one was taken for the analysis.

In the following three project topics will be described and analyzed. Every time projects of type *Progress 1* and *Progress 2* approaching the same topic will be analyzed and compared. On the one hand contents and progression of each project will be described. Afterwards both projects will be analyzed concerning *Creativity 1* and *Creativity 2*. Here relationships between creativity and the progression of projects will be considered.

An example of Creativity 1 of student [S1] is given by a project of coding with Compact Disk (CD). In the beginning he attends to coding, decoding and implied the topic binary code treated before. Interest in details of coding and the transfer of waves appeared. Furthermore he asked himself what might happen with damages or pollutions of a CD. Here [S1] included the Reed-Solomon error correction treated before.

Afterwards [S1] examined the functionality of the phonograph record. He explored the difference between the data transfer of phonograph record and CD. Moreover he analyzed the working of MP3-format. During this sequence he came across to Fourier-transformation and had a look at complex numbers and the exponential function.

In contrast to [S1] the student [S2] processed the topic CD with Creativity 2. He included trigonometry, binary code, Hamming distance, and Reed-Solomon code in his project. All the topics were included in lessons before. [S2] did not include more topics into his project.

Students [S3] und [S4] chose the topic entropy in connection to coding theory. Based on a short introduction by the teacher and foundations of school [S3] considered the entropy from coding for some time. He came upon entropy from thermodynamics. Afterwards [S3] discovered several aspects of entropy in mathematics and physics and even connection between them. In addition he had a look at mathematical foundations of

thermodynamics. While editing the topic [S3] wanted to calculate the entropy of several systems. To avoid calculation by hand he learned foundations of Python. Furthermore while starting the documentation of his project [S3] came across a lot of formulae. To avoid writing down a lot of formulae with Word he learned LaTeX.

[S4] again processed the contents of the document of the teacher and added aspects of logarithm function and probability theory. Everything has been included in mathematics at school before.

[S5] and [S6] chose for their projects the topic about elliptic curves in coding. After a short introduction into elliptic curves by the teacher [S5] and [S6] started their projects. First they had a look at more foundations of elliptic curves. Afterwards [S6] continued coding with elliptic curves with already known algebra and in the beginning of the course treated finite fields \mathbb{Z}_p with p prime as well as familiar analysis. By contrast [S5] continued with elliptic curves and a look at coding but added partial derivation, Public Key as well as proofs of mathematical contains.

An exception is given by another student [S7]. After sometime of his project concerning elliptic curves he attended to a lot of topics:

- Euclidean algorithm for computing the GCD
- Public Key and RSA (Rivest, Shamir & Adleman)
- Riemann's ζ -function
- Multidimensional calculus

[S7] left the topic with elliptic curves this way.

After induction [S1], [S3], and [S5] conducted their projects with consolidation of functional backgrounds. One can find the connection to Creativity 1, e.g. by [S1]:

[S1]: [...] if it's a more complicated exercise, one needs creativity to apply the right ones (algorithm a.s.o.)

([...] wenn das ne größere, komplexere Aufgabe ist, [...] muss man schon eine gewisse Kreativität beweisen, um die Richtigen immer anwenden zu können)

[S3] described creativity in a similar way:

[S3]: [...] one needs creativity anyway, because proofs or something else are put together with different parts of mathematics

([...] trotzdem brauch man noch Kreativität, denn oft genug sind ja noch Beweise oder so, aus verschiedenen Bereichen der Mathematik zusammengesetzt)

Alike described by [S5]:

[S5]: [...] that somebody, who is able to understand all of it and knows, why it works, [...] finds a solution with his creativity

([...] dass jemand, der wirklich das gesamte mathematische Verständnis hat und genau weiß wieso die Sachen so funktionieren wie sie funktionieren, [...] eben mit Hilfe seiner Kreativität sich einen eigenen Lösungsweg herausfindet)

On the other hand Creativity 2 appears with [S2]:

[S2]: [...] one can choose [creative], which procedures to take, but one always needs to choose the same procedure
([...] man kann zwar [kreativ] auswählen, welche Prozeduren, aber man muss [...] schließlich [...] immer die gleichen Prozeduren wählen)

Alike with [S4]:

[S4]: Creativity always plays a role, because if one [...] applies given formulae one will find the right solution.

(Kreativität spielt [...] immer eine Rolle, denn wenn man [...] den vorgegebenen Formeln [...] folgt kann man zu den richtigen Lösungen kommen.)

[S6] shares this opinion.

Connections between the processes of projects and the opinion of creativity are visible for all students [S1] to [S6]. If a student described creativity by Creativity 1, his project's process was of type Progress 1. In case of Creativity 2 the process was of type Progress 2. These relations appeared for 35 of 39 students of the four project courses.

REFLECTION

Projects and their processing as well as students' opinion might be divided into two types. Furthermore one can find relationships between student's project type and their perception of creativity. The results offer a relationship to school levels of Liljedahl & Sriraman (2006). The school level (iii) is connected with Creativity 2, where the process resulted in insightful solution under usage of its own technical foundations. In Creativity 1 besides school level (iii) one might find (iv), the formulation of new questions. Afterwards old problems/projects might be regarded from a new point of view and lead to new parts of the projects, e.g. by [S1], [S3] and [S5] or even encourage for new topics, for example [S7].

The perceptions of creativity by students might disagree with the perception of creativity of outsiders. Students often are postulated creativity by solving exercises a.s.o. In Leikin et al. (2013) teachers "consider students to be creative if they have investigative abilities, are mathematically flexible, and succeed in problem solving". In contrast the study shows that students' perception of creativity distinct from each other. Aha!Moments might appear in different ways and maybe not appear to teachers as Aha!Moments from their point of view. But with another look at the Progress of results one might realise Aha!Moments.

References

- Kattou, M., Kontoyianni, K., & Christou, C. (2009). Mathematical Creativity through Teachers' Perceptions. In Tzekaki, M., Kaldrimidou, M. & Sakonidis, H. (Ed.), *Proceedings of the 33rd Conference of the International Group for the Psychology of Mathematics Education* (Vol. 3, pp. 297–304). Thessaloniki, Greece.

- Kloosterman, P., & Stage, F. K. (1992). Measuring beliefs about mathematical problem solving. In: *School science and mathematics* 92 (3), p. 109-115.
- Kultusministerkonferenz (2013). *Vereinbarung zur Gestaltung der gymnasialen Oberstufe in der Sekundarstufe II: Beschluss der Kultusministerkonferenz vom 07.07.1972 i.d.F. vom 06.06.2013*. Retrieved from http://www.kmk.org/fileadmin/veroeffentlichungen_beschluesse/1972/1972_07_07-Vereinbarung-Gestaltung-Sek2.
- Liu, P.-H., & Liu, S.-Y. (2011). A cross-subject investigation of college students' epistemological beliefs of physics and mathematics. *The Asia-Pacific Education Researcher*, 20(2), 336-351.
- Leikin (2007), R. Habits of mind associated with advanced mathematical thinking and solution spaces of mathematical tasks. In *Proceedings of the fifth conference of the European Society for Research in Mathematics Education—CERME-5* (pp. 2330–2339).
- Leikin, R. (2009). Exploring mathematical creativity using multiple solution tasks. In Leikin, Roza, Berman, Abraham & B. Koichu (Eds.), *Creativity in mathematics and the education of gifted students* (pp. 129–145). Rotterdam: Sense Publ.
- Leikin, R., Subotnik, R., Pitta-Pantazi, D., Singer, F. M., & Pelczer, I. (2013). Teachers' views on creativity in mathematics education: An international survey. *ZDM*, 45(2), 309–324.
- Liljedahl, P. (2004). *The AHA! experience. mathematical contexts, pedagogical implications* (Unpublished doctoral dissertation). Simon Fraser University, British Columbia, Canada.
- Liljedahl, P. G. (2005). Mathematical discovery and affect: The effect of AHA! experiences on undergraduate mathematics students. *International Journal of Mathematical Education in Science and Technology*, 36(2-3), 219–234.
- Liljedahl, P. (2013). Illumination: An affective experience? *ZDM*, 45(2), 253–265.
- Liljedahl, P., & Sriraman, B. (2006). Musings on mathematical creativity. *For the Learning of Mathematics*, 26(1), 17–19.
- Mann, E. L. (2006). Creativity: The essence of mathematics. *Journal of the Education of the Gifted*, 30(2), 236–260.
- Ministry of Education in NRW (2010). *Handreichung Projektkurse in der gymnasialen Oberstufe*. Retrieved from <http://www.schulentwicklung.nrw.de/cms/projektkurse-sii/angebot-home>
- Nadjafikhah, M., Yaftian, N., & Bakhshalizadeh, S. (2012). Mathematical creativity: some definitions and characteristics. *Procedia - Social and Behavioral Sciences*, 31, 285–291.



MATHEMATICS TEACHING-RESEARCH JOURNAL ONLINE
VOL 8, N 1-2
Fall and Winter 2015/16

- Schommer-Aikins, M., Mau, W.-C., Brookhart, S., & Hutter, R. (2000). Understanding Middle Students' Beliefs About Knowledge and Learning Using a Multidimensional Paradigm. *The Journal of Educational Research*, 2(94).
- Sriraman, B. (2005). Are Giftedness and Creativity Synonyms in Mathematics? *The Journal of Secondary Gifted Education*, 17(1), 20–36.
- Stoppel, H., & Neugebauer, C. (2014). Epistemological Beliefs and Student Choices. In P. Liljedahl, C. Nicol, S. Oesterle, & D. Allan (Eds.), *Proceedings of the 38th Conference of the International Group for the Psychology of Mathematics Education and the 36th Conference of the North American Chapter of the Psychology of Mathematics Education* (Vol. 6, p. 392). Vancouver, Canada: PME.
- Torrance, E. P. (1974). *Torrance Tests of Creative Thinking: norms and technical manual*. Lexington, MA: Personnel Press.
- Urhahne, D., & Hopf, M. (2004). Epistemologische Überzeugungen in den Naturwissenschaften und ihre Zusammenhänge mit Motivation, Selbstkonzept und Lernstrategien. *Zeitschrift für Didaktik der Naturwissenschaften*, 10, 71–87.

Phases of a ten-year old student's solution process of an insight problem as revealed by eye-tracking methodology

Csaba Csíkos

Institute of Education, University of Szeged, Hungary

csikoscs@edpsy.u-szeged.hu

János Steklács

Kecskemét College, Hungary

steklacs@gmail.com

Abstract

The study focuses on a 10 year old student's problem solving process on a mathematical insight problem. We hypothesized that phases of the solution process as revealed by eye-tracking methodology can be clearly identified, and the emergence and suppression of the student's a-ha experience can be detected. In this research, one minute long observation of the solution process of a ten-year-old student was documented and analyzed. The results suggest that different phases of the solution process can be distinguished and described. Among the educational consequences of the results, the potential of merging objective eye-tracking data with qualitative narratives and identifying the suppression of a-ha experience are of special importance.

Keywords: eye-tracking, a-ha experience, word problem

Introduction

Mathematical word problems are often considered as the archetype tools of measuring how students are able to apply their mathematical knowledge. Word problems have a long historical and educational route to become the unavoidable means of testing students' mathematical knowledge. A huge body of the literature focused on the types of word problems and on the solution process. Insight problems where the so-called a-ha experience can be observed are in the focus of several investigations. The current research aims to provide evidence on the potential eye-tracking methodology may provide when revealing different phases of insight word problem solution process.

The process of mathematical word problem solving

Mathematical word problems are verbal descriptions of mathematical problem situations (Verschaffel, Greer & De Corte, 2000). Previous research provided several classifications of simple arithmetic word problems (see e.g., Morales, Shute & Pellegrino, 1985; Riley and Greeno, 1998), and there can even developmental milestones be identified in the efforts to describe the related mental processes. Research on the mental processes that

underlie arithmetic word problem solving can be interlinked by three milestones in the field. First, Kintsch and Greeno (1985) proposed a model that describes the solution process as a set of sequential, well-defined steps and working memory limitations play a decisive role in their model. Second, Hegarty, Mayer and Monk (1995) suggested a model that permits ramifications and loops in the mental processes. There is one crucial step in the process: whether the problem solver succeeded in building an appropriate problem representation or not. The third line of research, hallmarked by the Leuven research team lead by De Corte and Verschaffel (1981), highlighted the metacognitive components of word problem solving. For instance, the need for verification of the outcome of an arithmetic operation may require metacognitive considerations (see also Pólya, 1945).

Insight problems and a-ha experience

Within the various types of word problem, non-routine and puzzle-like word problems are often labeled as insight problems as opposed to move problems. Still little is known about the cognitive processes involved in solving insight problems (Batchelder & Alexander, 2012). The way how move problems are solved is labeled as ‘mental set’ (Öllinger, Jones, Knoblich, 2008), referring to routine procedures during the solution process, whereas insight problems require unconventional methods of solution. Insight problems give the opportunity of sudden cognitive transactions (Spivey & Dale, 2006) by means of changing the initial problem representation (Knoblich, Ohlsson, & Raney, 2001). Puzzle-like word problems offer ground for evoking a-ha experience which means that having induced an initial frustration caused by the lack of immediate solution, sudden changes in brain-correlated mind states can be detected (Spivey & Dale, 2006).

Some tasks are more eligible to provoke sudden ideas than others (these tasks may be labelled “insight problems”), therefore when investigating the insight phenomenon it is the tasks characteristics that provide a first variable in research design. However, for those problem solvers who have already encountered with many insight problems, such

problems may seem to be somewhat easier and even of routine-type. This principle relates to individual differences, and might be referred as the process dimension of insight. The third dimension of the insight phenomenon as a psychological process is whether the problem solver experience an involuntary process called the a-ha experience (Öllinger & Knoblich, 2009).

The detection of an involuntary psychological process requires an objective method of observation. Eye-tracking may serve as one of the possible observation methods. In doing so, Johnston-Ellis (2012) used anagram problems, Knoblich, Ohlsson and Raney (2001) chose to apply matchstick arithmetic problems, Jones (2003) tested participants by a computerized version of a game about maneuvering a taxi in a car park. All these previous studies have proven that eye-tracking has unique sensitivity to inspect the insight phenomenon (Knoblich, Öllinger, & Spivey, 2005). Previous research (Jacob & Hochstein, 2009) proposed eye-tracking-data-based quantitative description of the possible transition between psychological processes. In their research, while searching for identical cards on the screen, and matching them by clicking, the number of fixations tended to be changed before the conscious recognition of the pairs.

The aim of the current research is to observe and analyze the solution process of an insight problem. In line with the three dimensions of the insight phenomenon, a task that may provoke a-ha experience being solved by a student for whom the task is certainly a task of routine-type was used. The main research question is whether it is possible to identify different phases of the solution process of such a problem. It is hypothesized that eye-tracking data will clearly show different phases of the solution process, and it was also assumed that the possible emergence of the a-ha experience can be detected.

Our original intention was to find an objective method to describe the solution process of an insight problem. In previous publications we focused on the potentially reportable strategic processes of reading and mathematical abilities. It was experienced several times that students are unable to appropriately and accurately report on their own thinking processes. This might in part due to their poor vocabulary, but there are cases

where even adults might suffer from finding a fluent description of their own thinking. As part of a quantitative educational research project on the role of number stimulus modality in mathematical problem solving, an insight problem was administered to students with the aim of revealing their possible a-ha experiences.

It was hypothesized that the emergence of the a-ha experience can be observed by means of eye-tracking methodology as opposed to students' self-reports when post-hoc narratives may either embellish their real thinking process or students may be unable to verbally report on their thinking. Actually we hypothesized that the emergence of the a-ha experience would be observed by means of sudden changes in the eye-movement pattern.

Methods

Rationale for using mixed methods approach

Pondering towards finding an objective method for detecting the emergence of a-ha experience, collecting quantitative data on the thinking process seemed to be inevitable. In this mixed methods study (Johnson & Onwuegbuzie, 2004) the numerical variables from an eye-tracking session were combined with qualitative interpretive analysis. According to Johnson and Onwuegbuzie (2004), eight possible types of mono- and mixed methods can be distinguished. Our intention to objectively detect the emergence of a-ha experience is clearly a research objective of quantitative nature. Also the data set was quantitative with time measures. However, we performed qualitative data analysis, since there was no previous quantifiable criterion when and how the emergence of an a-ha experience can be revealed. The qualitative data analysis was based on a series of consultations with pre-service and in-service mathematics and reading teachers. On regular university courses, teachers watched the video footage analyzed in this study in silence without any previous commentary on the emergence of an a-ha experience. At the phases shown in Figures 7 to 9 in the Results section, the audience burred, and during the discussion on the footage, the colleagues agreed upon the emergence and the temporal suppression of the student's a-ha experience.

The task

The task was presented on the screen of the eye-tracking machine. The distance from the screen was 70 cm, and the text seen in Figure 1 was displayed:

Egy repülőgép pilótája vagy.
Berlinben felszáll 10 ember.
Budapesten leszáll 9 ember, és felszáll 6,
majd végül Bécsben leszáll 4, és felszáll 12.
Hány éves a pilóta?

Figure 1 Display of the puzzle-like task.

Note. The translation of the text is as follows: **“You pilot the airplane. In Berlin, 10 people board. In Budapest, 9 people get off, and 6 people board, and finally, in Vienna, 4 people get off, and 12 people board. How old is the pilot?”**

Following the ‘didactical contract’ (Brousseau, 1997), students are expected to find the task meaningful, and therefore realize that it is them who pilot the airplane therefore the

answer should be their age. Furthermore, the task offers the compliance of the routine algorithm of collecting numbers and executing arithmetic operations. The procedure starts with inspecting the figures and the possible relations between them. Hence a possible (albeit meaningless) solution would be $10 - 9 + 6 - 4 + 12 = 15$. The question concerns the age of the captain, so instead of adding and subtracting the numbers of the passengers, students should find the semantic connection between the first and last sentences. Even in this latter case, the reality of the situation described in the word problem is seriously questioned not only because of the feasibility of such a trip, but mainly because of the impossibility of being a pilot at the age of 10 or 11. Consequently, there is no 'correct' answer for this task, but the semantic connection between the first and last sentences makes it possible for the students to have an a-ha experience.

Data collection and analysis

Data collection took place in the school. 24 students participated in the experiment, and they were tested in a quiet room. Having solved a warming-up task and four simple arithmetic tasks, they finally encountered the sixth shown in Figure 1.

Eye movements were registered with a Tobii T120 eye tracker. The eye-tracking machine automatically record and store the data on students' fixations on the screen. The number and length of fixations on the screen indicate conscious and non-conscious processes in thinking (see e.g., Rayner, 1983). Researchers usually define several areas of interests on the screen, and the number and length of fixations can be analyzed in view of these areas. In usual (quantitative) data analysis procedures different fixation time measures are to be computed (see e.g., De Corte, Verschaffel, & Pauwels, 1990). These measures in our study have already been presented (Authors, 2013). Our aim was now to zoom in one student's problem solving process. Besides collecting those usual quantitative measures, we aimed for qualitative insights about the reasoning process.

The student

One of the students, pseudo-name will be Oliver, proved to be very typical concerning the quantitative eye-tracking measures on the puzzle-like tasks, but on a previous

arithmetic skill test, he achieved the second highest score in the group. Good arithmetic skills can compensate for even possibly low level of reading skills when solving arithmetic tasks (Nortvedt, 2011). We aim to analyze Oliver's solution processes who has above the average counting skills, but has average reaction time measures on this puzzle word problem.

Oliver was 10 year and 9 months old at the time of the experiment. During this six task experiment, interestingly, he failed to solve two tasks where the number components of the word problems were written in number words and not in Arabic numerals. As for the puzzle-like task, he belonged to the small group of five who succeeded in a way that they could semantically connect the first and last sentences and claim that the pilot was as old as they were.

Results and discussion

The results of the current study are organized according to the timeline of the video footage. As it was mentioned, besides having had a quantitative research objective and having collected quantitative data (frequency and length of fixations), the analysis was based on qualitative narratives agreed upon by pre-service and in-service mathematics and reading teachers. The number and length of fixations on different areas of interests will be presented by means of several screenshots of the footage, and the qualitative analysis serves as the discussion of these results.

It took Oliver 1 minute and 5 seconds to answer the question: How old is the pilot? At the end of this interval, he answered: '10 years old, since it is me who the captain was'.

The Results section contains a narrative analysis of this time interval.

Phases of the solution process

0:00 – 0:02 The first sentence was read during only 2 seconds. The two short words received only one fixation, and the two longer words required two fixations.

0:02 – 0:06 The second row required four seconds with seven fixations.

0:06 – 0:10 The third row consumed another four seconds with eight fixations.

0:10 – 0:15 Until this, the reading process was straightforward and sequential, without any rereading or without skipping any part of the text. From now on, Oliver started to jump in the text. The way of his thinking may be reflected by the way of the fixation visualization pattern. The first jump in the text is shown in Figure 2.

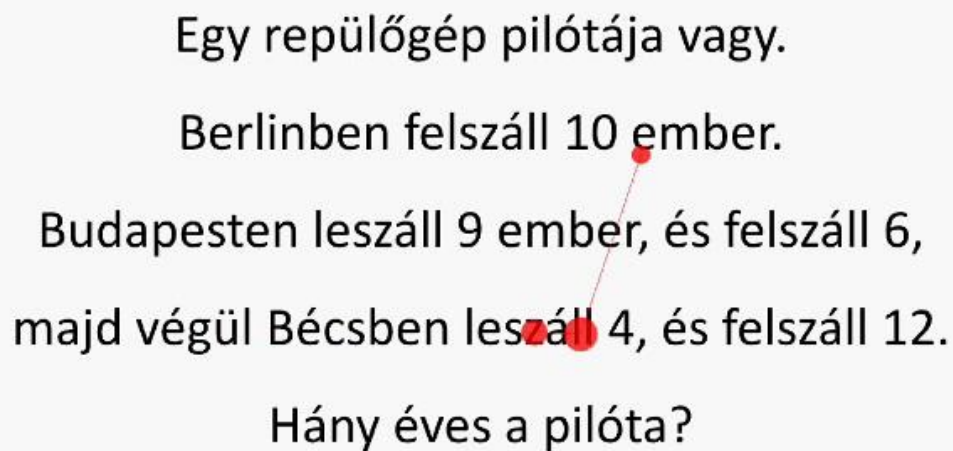

Egy repülőgép pilótája vagy.
Berlinben felszáll 10 ember.
Budapesten leszáll 9 ember, és felszáll 6,
majd végül Bécsben leszáll 4, és felszáll 12.
Hány éves a pilóta?

Figure 2 Screenshot at 0:14.60 The coordination is between “10 people” & “4 people get off”

By that time, Oliver may have realized that his working memory is full of data: places and numbers were read, and before reading the last numeral, he decided to read the numeral of the second row again.

The 15th and 16th seconds of the solution process brings even further evidence about using the ‘search for numerals’ strategy (Reusser & Stebler, 1997). Figure 3 shows how quickly the first three numerals were reread.

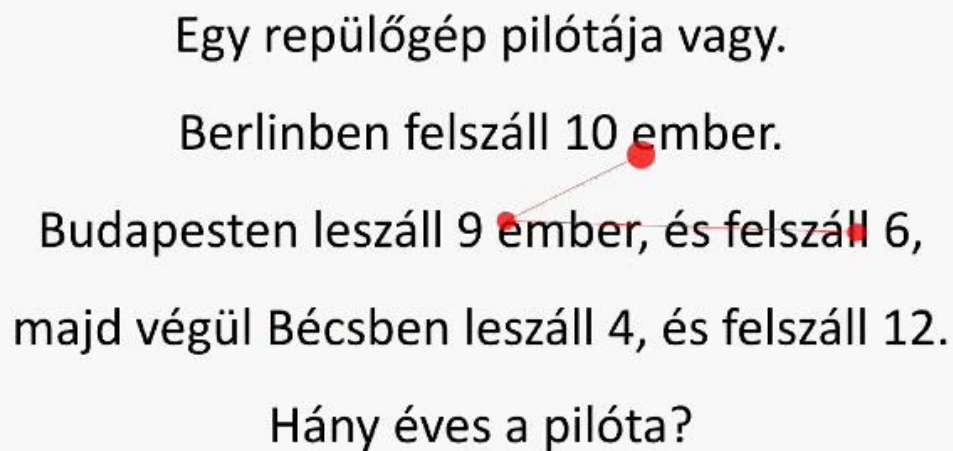

Egy repülőgép pilótája vagy.
Berlinben felszáll 10 ember.
Budapesten leszáll 9 ember, és felszáll 6,
majd végül Bécsben leszáll 4, és felszáll 12.
Hány éves a pilóta?

Figure 3 Screenshot at 0:15.83. The coordination between „10 people board”, „9 people get off” and „6 people board”

These three very quick fixations on the numerals clearly indicate a conscious strategy.

0:15 – 0:21 Oliver reads carefully the remaining numeral (note: the last figure has not been read previously because of the chosen regression seen in Figure 2. It lasted five seconds to read the last two numerals, having fixated not only them, but on the keywords

telling “take-off” and “landing” passengers. Having read all numerals and the keywords carefully, Oliver finally chose to read the question. Until this point he seemed to be rather sure that the question will be meaningful, at least it concerns the number of passengers on board.

0:21 – 0:25 Oliver reads the question in the fifth row, exactly twice, fixating three times each, and a third rereading occurred on the words “the pilot”. Then he started to jump backwards on numerals as seen in Figure 4.

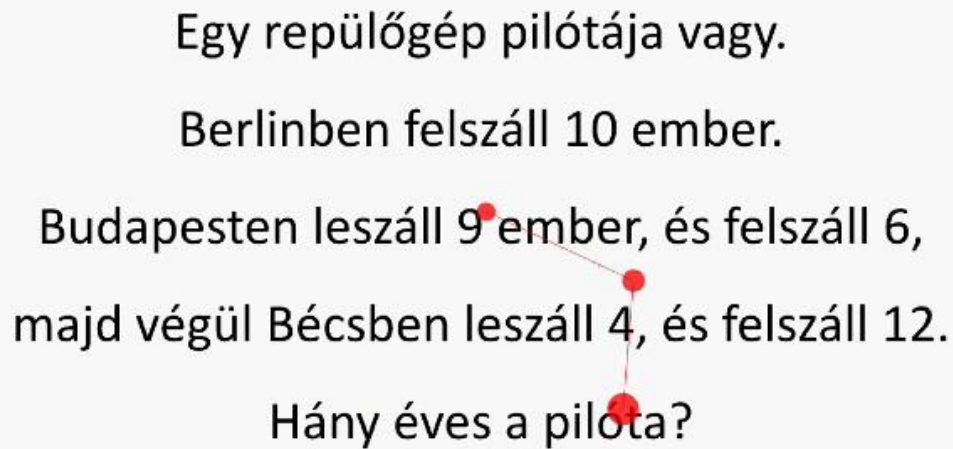

Egy repülőgép pilótája vagy.
Berlinben felszáll 10 ember.
Budapesten leszáll 9 ember, és felszáll 6,
majd végül Bécsben leszáll 4, és felszáll 12.
Hány éves a pilóta?

Figure 4 Screenshot at 0:24.66. The coordination between 9, 4 and „pilot”

0:25 – 0:26 Having read the numerals 4 and 9 again (it was the third time for reading the 9 the 4), he decided to start reading the text from the very beginning again as seen in Figure 5.

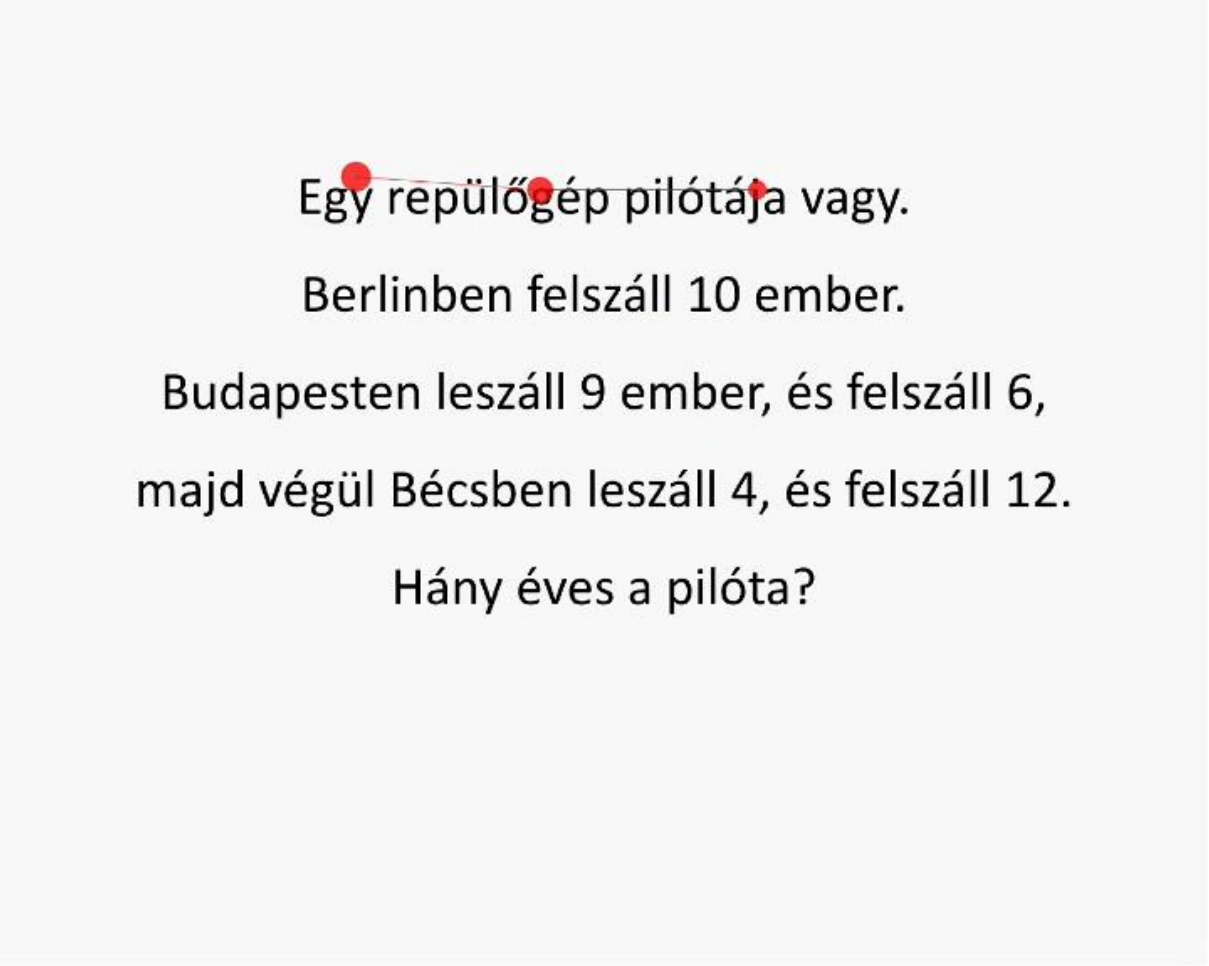

Egy repülőgép pilótája vagy.
Berlinben felszáll 10 ember.
Budapesten leszáll 9 ember, és felszáll 6,
majd végül Bécsben leszáll 4, és felszáll 12.
Hány éves a pilóta?

Figure 5 Screenshot at 0:25.74 Fixation on “You pilot the airplane”

0:26 – 0:29 There is no fixation point on the screen. Oliver looked above the screen for three seconds, and then restarted gazing upon the screen.

0:29 – 0:33 Oliver reads patiently (with the usual fixation frequency) the third row. But suddenly starts reading the first row again.

0:33 – 0:37 Reading continues in the second row at the usual pace. Reading seems to continue with the third row, but suddenly, as seen in Figure 6, Oliver jump back to the first word of the second row, and to the first word of the first row.

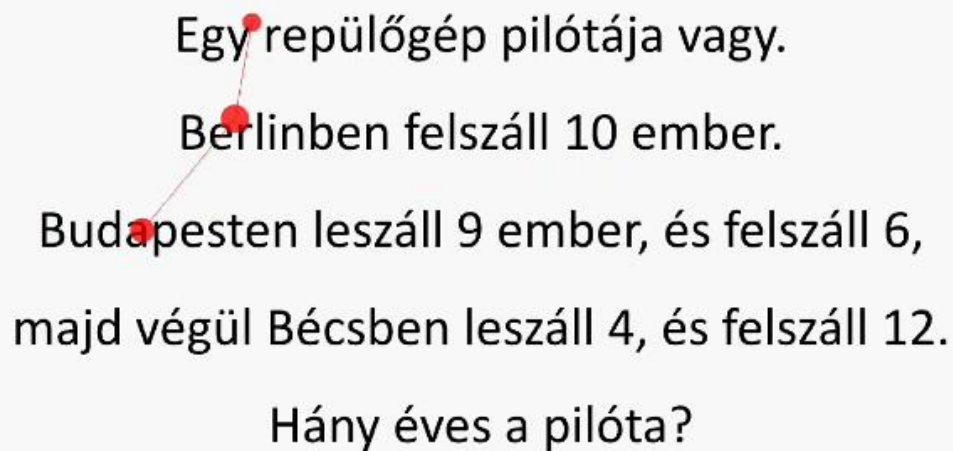

Egy repülőgép pilótája vagy.
Berlinben felszáll 10 ember.
Budapesten leszáll 9 ember, és felszáll 6,
majd végül Bécsben leszáll 4, és felszáll 12.
Hány éves a pilóta?

Figure 6 Screenshot at 0:36.87

The sudden change in the pace of reading, and the regression to the beginning may indicate the recognition of the importance of the first sentence.

0:37 – 0:40 Reading the first sentence with the usual fixation points for the fourth time might even indicate the loss of interest or stepping down from the solution process. But at the end of the first row, fixation on the word “vagy” [literally: you are] lasts much longer

than before. The animated visualization shows that fixation on that word started at 0:38.33, and terminates at 0:40.07, with two long fixation periods on the same word. This long double fixation on the semantically most important key word could lead Oliver to the decision that instead of collecting numerical information, from now on he focused on the verbal components of the task.

Emergence and suppression of an a-ha experience

The solution process seemed to be somewhat struggling for 40 seconds. The next seconds witness the emergence and suppression of an a-ha experience Oliver might undergo. The emergence phase has two parts. First, we see the insistence on fixating again and again on the key word in the first sentence. This insistence was already present at the double fixation interval, but it still continues. The second part is the fixation oscillation between the first and last rows. It can be clearly seen that Oliver possessed the solution; he realized that the semantic connection between the first and the last sentences was important. However, for some more seconds he suppressed that insight, and restarted the reading process.

Figure 7 illustrates the first phase of the emergence of a possible a-ha experience.

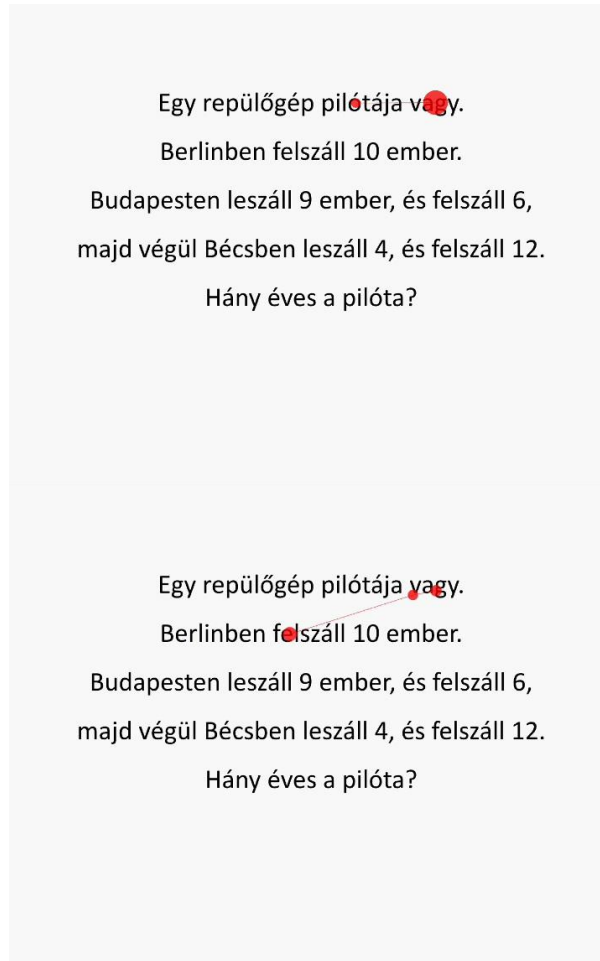

Figure 7 Screenshots at 0:44.06 and 0:45.89 Coordination between „you pilot” and „board”

The second phase of the emergence of an a-ha experience is illustrated in Figure 8. Similarly to Figure 7, this twin figure shows two moments when it is clearly observable that fixations oscillate between the first and the last rows.

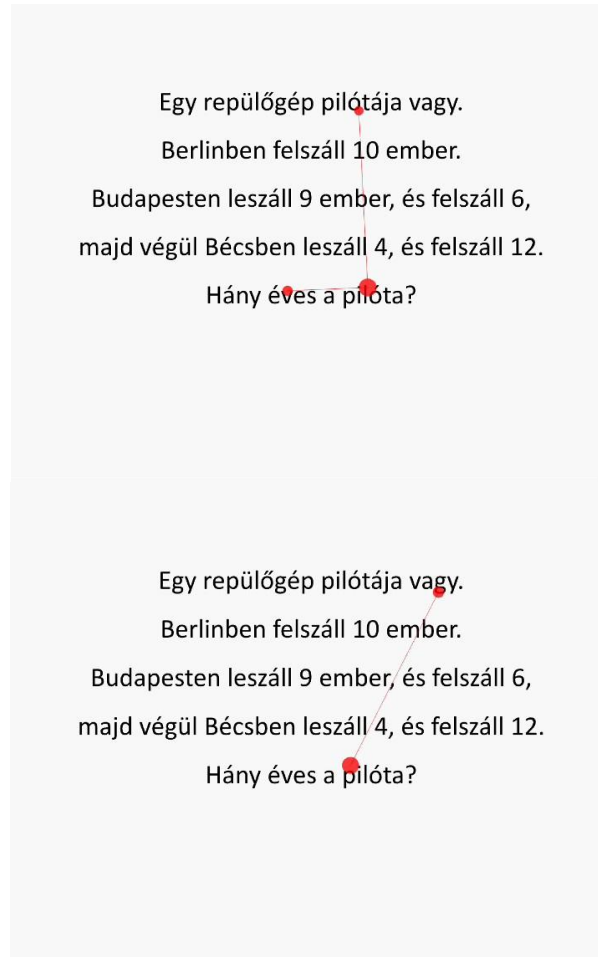

Figure 8 Screenshots at 0:51.80 and 0:52.71 Coordination between „pilot”, „pilot” and „old” [literally: year]

There was even a third quick transition in fixation between the last and first rows at 0:53.42, and there was a fourth quick transition at 0:56.21. During these seconds only the first and last sentences received fixations, and none of the middle three rows.

Every time this footage was shown at university courses the audience burred during these seconds. It was so obvious for everyone (colleagues, students with various background) that Oliver fully understand the task and he already knows the answer.

Much to the audience’s surprise, the footage continued in an unexpected way. Oliver

looked out of the screen to the right, and when coming back at 0:58.55 he started to read the middle passages that were thought (by the observers) to be recognized as irrelevant to the solution.

Figure 9 illustrates the disappointing moment when instead of finishing the task by providing an answer based on semantic connection of the first and last sentences, Oliver started to read numerals again.

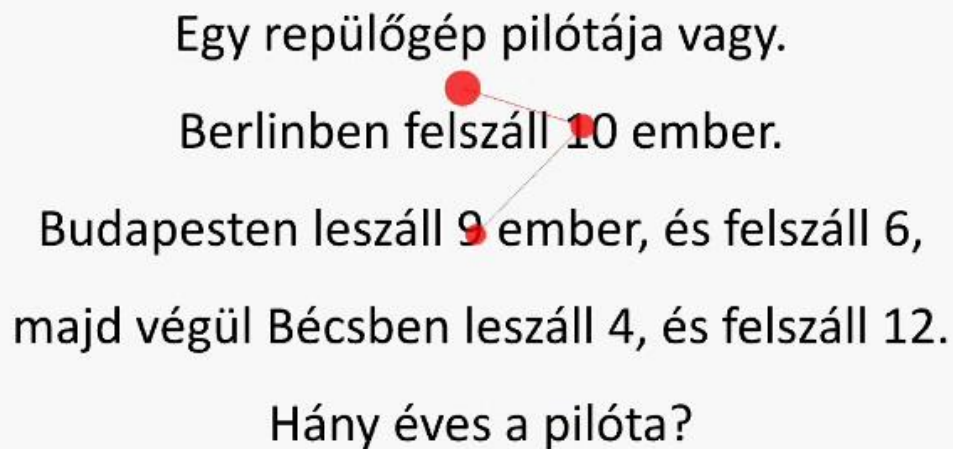

Egy repülőgép pilótája vagy.
Berlinben felszáll 10 ember.
Budapesten leszáll 9 ember, és felszáll 6,
majd végül Bécsben leszáll 4, és felszáll 12.
Hány éves a pilóta?

Figure 9 Screenshot at 0:59.41

Fortunately, and much to the observers' relief, after some seconds, Oliver's fixations disappeared from the middle rows. Figure 10 shows the final moment of the solution process. (When the researcher heard the expected solution, he terminated the probe and

the video footage by hitting the space bar on the computer.) The last moment finds Oliver fixating on the key words of the first sentence.

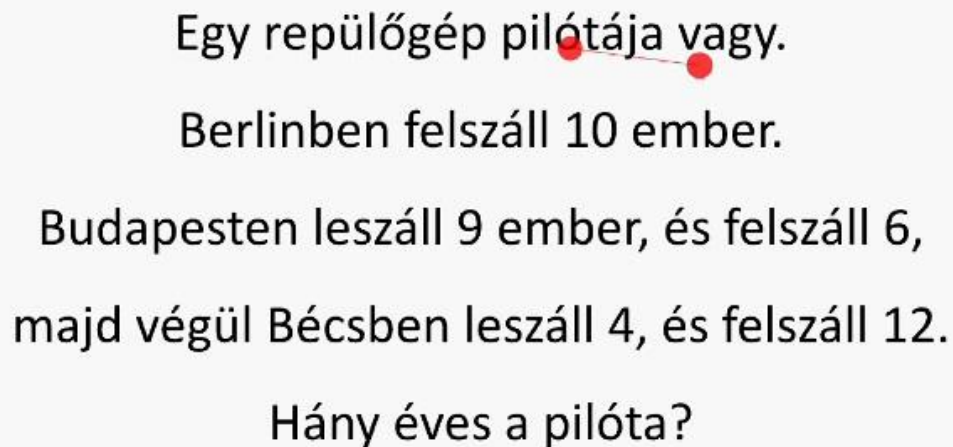

Egy repülőgép pilótája vagy.
Berlinben felszáll 10 ember.
Budapesten leszáll 9 ember, és felszáll 6,
majd végül Bécsben leszáll 4, és felszáll 12.
Hány éves a pilóta?

Figure 10 Screenshot at 1:05.05 Fixation on „you pilot”

Conclusions

In this case study we presented a narrative analysis of a 65 second long video footage (animated visualization) that showed a 10 year old boy's eye fixations during a mathematical word problem solving session. It became clear from the eye-tracking data that the boy applied the well-known strategy of 'search for numbers then connect them with mathematical operations'. It took 25 seconds (almost half of the complete solving process) to read the task. Some parts were read twice. The next 15 seconds witnessed a

strategy terms, i.e. instead of jumping from numerals to numerals in the rereading phase; he decided to focus on semantic elements of the tasks. In the next 15 seconds we saw the emergence of an a-ha experience in two phases. First, it became obvious for the boy that the essential content element can be found in the first and the last sentence. Then oscillation in the eye-fixations between the first and the last sentence was observable. In the last ten minutes a seemingly disappointing rereading phase occurred (suppression of the a-ha experience), but finally the boy succeeded in finding a semantically appropriate (albeit from a mathematical point of view unrealistic) solution to the task.

The novelty of our research was providing a qualitative description of a student's word problem solving procedure. It gave the opportunity to match theoretically established model phases and empirically supported data. Subsequently our aim was to enrich the case study methodology by means of amalgamating objective data and assigned narratives based on agreement among experts.

The generalizability of our results can be extended in two ways. Either the number of participants who supposedly have a-ha experience while solving a mathematical problem should be increased or the discussion of the current case study can be enriched by means of having quantitative data about the agreement among experts who watch the critical phases of the video footage. The question of generalizability is therefore obviously connected to the possible future extension of this research.

Methodological considerations

In light of the 21st century shift in advocating scientifically-based research (the term has several facets, see Denzin, Lincoln, & Giardina, (2006) eye-tracking methodology may provide the means to meet classical quantitative research criteria of objectivity, reliability and validity, and at the same time it provides enormous data sets that permit focusing on case studies and provide platforms for critical and interpretive narratives. In this research, eye-tracking was done by collecting objective and sensitive data about each hundredths of a second during a 65 second long interval. The animated visualization was presented

to various audiences, and independently of their status as pre- or in-service teachers, the same crucial moments were identified.

As for the three criteria of scientificity proposed by Hegedus (2010), we (1) attempted to attend to empirical epistemology of inductive nature, (2) reflected on the novelty our claims proposed, and will soon reflect on the limitations of our ideas, and (3) in the next paragraph we try to identify the dynamic components of our investigation.

Our contribution to the “circular endeavor of scientific discovery” (Hegedus, 2010, p. 391) appears in an invitation to criticize possible holes in our argument in order to refine the methodology we used. Should we have examined more students’ solution processes without thinking of them as units in a sample? Since we had the opportunity to observe many people’s reactions while watching the 65 second video footage, can our approach be considered as a case of investigator triangulation?

The study certainly had some limitations. The students (of course, also Oliver) had previously solved routine word problems before they were shown the puzzle-like task. Although, as Verschaffel, Greer, and De Corte (2000) summarized, contextual changes have only slight effects on the achievement of non-routine word problems, in this case the context of using an eye-tracking machine may have in itself caused changes in attitude and performance. A second methodological concern is of ethical nature. Since it is quite obvious that insight problems (by definition) induce frustration in longer or shorter periods of the problem solving process, some may argue that students should not be exposed to such puzzle-like tasks. While we agree in general that exposing students to frustrating experiences should be avoided, in the actual experiment students’ possible frustration experience was reduced by (1) employing well-trained educational researcher in the data collection process, and (2) reassuring them that their valuable contribution to an educational experience will not be connected to their current school performance and marks.

Educational issues

The educational considerations are twofold. From a theoretical and methodological point of view, the evidence the eye-tracking methodology yielded draws our attention to the potential what merging the qualitative narratives and the objective eye-tracking data may provide in describing mental processes. This methodological prospect has the potential to reveal other high-level processes and representational shifts that have practical relevance, and to which rich instructional methodologies and conceptual frames have already been developed, e.g. metacognitive strategies, aesthetic value forming.

The second aspect of the educational implications more closely relates to the current phenomenon we investigated. The emergence and temporary suppression of an a-ha experience while solving a word problem points to several didactical concerns. (1) The use of the routine algorithm of collecting figures in the text of the word problem without taking the semantic content into account, (2) rereading some numerals (because of working memory constraints) even before reading the question of the task, (3) hesitating and struggling after the emergence of the a-ha experience are all consequences of the aims and the means why and how word problems are taught in the elementary schools. These three concerns are worth being embedded in teacher education and continuous professional development courses, since these ‘symptoms’ are results of teaching and learning processes that are not in accordance with declared curricular targets and aims!

References

- Batchelder, W. H., & Alexander, G. E. (2012). Insight problem solving: A critical examination of the possibility of formal theory. *The Journal of Problem Solving*, 5, 56-100. <http://dx.doi.org/10.7771/1932-6246.1143>
- Brousseau, G. (1997). *Theory of didactical situations in mathematics*. N. Balacheff, M. Cooper, R. Sutherland, & V. Warfield (Eds. & Trans.). Dordrecht, The Netherlands: Kluwer.

- Csíkó, C., & Steklács, J. (2013). /The role of number representation modality in solving word problems: An eye-tracking study./ Paper presented at the 15th European Conference for Research on Learning and Instruction, München, Germany, August 27-31.
- De Corte, E., & Verschaffel, L. (1981). Children's solution processes in elementary arithmetic problems: Analysis and improvement. *Journal of Educational Psychology*, 58, 765-779. <http://dx.doi.org/10.1037/0022-0663.73.6.765>
- De Corte, E., Verschaffel, L., & Pauwels, A. (1990). Influence of the semantic structure of word problems second graders' eye movements. *Journal of Educational Psychology*, 82, 359-365. <http://dx.doi.org/10.1037/0022-0663.82.2.359>
- Denzin, N. K., Lincoln, Y. S., Giardina, M. D. (2006). Disciplining qualitative research. *International Journal of Qualitative Studies in Education*, 19, 769-782. <http://dx.doi.org/10.1080/09518390600975990>
- Hegedus, S. (2010). Appreciating scientificity in qualitative research. In B. Sriraman & L. English (Eds.), *Theories of mathematics education. Seeking new frontiers* (pp. 381-399). Berlin – Heidelberg: Springer. http://dx.doi.org/10.1007/978-3-642-00742-2_36
- Jacob, M., & Hochstein, S. (2009). Comparing eye movements to detected vs. undetected stimuli in an Identity Search task. *Journal of Vision*, 9(5):20, 1-16. <http://dx.doi.org/10.1167/9.5.20>
- Johnson, R. B., Onwuegbuzie, A. J. (2004). Mixed methods research: a research paradigm whose time has come. *Educational Researcher*, 33, 14-26. <http://dx.doi.org/10.3102/0013189X033007014>
- Jones, G. (2003). Testing two cognitive theories of insight. *Journal of Experimental Psychology: Learning, Memory, and Cognition*, 29, 1017-1027. <http://dx.doi.org/10.1037/0278-7393.29.5.1017>
- Knoblich, G., Ohlsson, S., & Raney, D. E. (2001). An eye movement study of insight problem solving. *Memory & Cognition*, 29, 1000-1009. <http://dx.doi.org/10.3758/BF03195762>
- Knoblich, G., Öllinger, M., & Spivey, M. J. (2005). Tracking the eyes to obtain insight into insight problem solving. In G. Underwood, (Ed.), *Cognitive processes in eye guidance* (pp. 355-375). Oxford University Press: Oxford – New York etc. <http://dx.doi.org/10.1093/acprof:oso/9780198566816.003.0015>

- Morales, R. V., Shute, V. J., & Pellegrino, J. W. (1985). Developmental differences in understanding and solving simple mathematics word problems. *Cognition and Instruction*, 2, 41-57. http://dx.doi.org/10.1207/s1532690xci0201_2
- Nortvedt, G. A. (2011). Coping strategies applied to comprehend multistep arithmetic word problems by students with above-average numeracy skills and below-average reading skills. *Journal of Mathematical Behavior*, 30, 255-269. <http://dx.doi.org/10.1016/j.jmathb.2011.04.003>
- Öllinger, M., Jones, G., Knoblich, G. (2008). Investigating the effect of mental set on insight problem solving. *Experimental Psychology*, 55, 270-282. <http://dx.doi.org/10.1027/1618-3169.55.4.269>
- Öllinger, M., & Knoblich, G. (2009). Psychological research on insight problem solving. In H. Atmanspacher & H. Primas (Eds.), *Recasting reality: Wolfgang Pauli's philosophical ideas and contemporary science* (pp. 275-300). Springer: Berlin – Heidelberg. http://dx.doi.org/10.1007/978-3-540-85198-1_14
- Pólya, G. (1945). *How to solve it*. Princeton, NJ: Princeton University Press.
- Rayner, K. (ed.) 1983. *Eye movement in reading. Perceptual and language processes*. New York: Academic Press.
- Reusser, K., & Stebler, R. (1997). Every word problem has a solution – The social rationality of mathematical modeling in schools. *Learning and Instruction*, 7, 309-327. [http://dx.doi.org/10.1016/S0959-4752\(97\)00014-5](http://dx.doi.org/10.1016/S0959-4752(97)00014-5)
- Riley, M. S., & Greeno, J. G. (1998). Developmental analysis of understanding language about quantities and of solving problems. *Cognition and Instruction*, 5, 49-101. http://dx.doi.org/10.1207/s1532690xci0501_2
- Spivey, M. J., & Dale, R. (2006). Continuous dynamics in real-time cognition. *Current Directions in Psychological Science*, 15, 207-211. <http://dx.doi.org/10.1111/j.1467-8721.2006.00437.x>
- Verschaffel, L., Greer, B. & De Corte, E. (2000). *Making sense of word problems*. Lisse: The Netherlands: Swets & Zeitlinger.



MATHEMATICS TEACHING-RESEARCH JOURNAL ONLINE
VOL 8, N 1-2
Fall and Winter 2015/16

Improving Gender Disparity in Scholarship Programs for Secondary-Level Mathematics Teachers

Rohitha Goonatilake†, Katie D. Lewis±, Runchang Lin†, and
Celeste E. Kidd§

†Department of Mathematics and Physics, ±Department of Curriculum and Pedagogy,
and §Office of Graduate Studies and Research
Texas A&M International University
5201 University Boulevard
Laredo, Texas 78041-1900

Abstract

Gender disparity in STEM Education has been a topic of much discussion among college faculty and administrators lately. Several remedies have been proposed and carried out with little to no positive impact to the situation.

This paper will give a glimpse into a scholarship program funded by the National Science Foundation (NSF) geared towards producing secondary school teachers in mathematics at Texas A&M International University (TAMIU), Laredo, Texas. This multifaceted program, the Robert Noyce Mathematics Teacher Scholarship Program (TAMIU-NMTSP), has seen improvements in female participation in all its components and is geared towards addressing the scarcity of qualified secondary-level mathematics teachers in today's high school classrooms to serve high-need schools. The primary accomplishment in the second year is that all project components were implemented for the first time. This included mandatory mentoring for all scholars, Texas Examinations of Educator Standards (TExES) review sessions, boot camp activities, two separate orientation forums for both new and returning scholars, summer internships, conferences, and participation in other related forums. One indication of the success of the program is that our first graduate, a new female scholar, secured her first teaching position as a fully certified secondary high school mathematics teacher immediately upon graduation in the Fall of 2015.

1. Preliminaries

Many factors affecting female participation in higher education have been studied. Yet the numbers of females entering the field of mathematics remains low. Female students seek majors other than mathematics, but a new trend is happening. While the gender gap seems widespread both across U.S. schools and in international comparisons, the high-

achieving girls are concentrated in schools with elite mathematics programs (Ellison & Swanson, 2010). Factors associated with this trend were examined through field visits in seven developing countries: Bangladesh, Cameroon, India, Jamaica, Seychelles, Sierra Leone, and Vanuatu (Brock & Cammish, 1997). A fundamental cultural bias that is in favor of males and economic factors appears to be the biggest obstacles to female participation in higher education in developing countries. Religious and legal factors had only indirect effects in addition to other growing needs. Significant initiatives aimed at addressing all aspects of the problem of female participation in higher education were carried out and they can be replicated in most other developing countries; however, the political desire to implement those initiatives, a conducive environments and policy consideration is largely lacking. In developed countries, the conditions, motivations, and gender equality make it possible for females to seek these opportunities in the field of education, particularly mathematics.

2. Literature Review

According to the American Association of University Women (AAUW), the gap between girls and boys in science, technology, engineering and mathematics (STEM) fields has been decreasing over the past 50 years. Several studies show that even though the number of girls in STEM fields is small compared to that of boys, girls tend to have better grades in these degrees (AAUW, 2015). According to the United Nations Division for the Advancement of Women (DAW, part of UN Women) and the United Nations Educational, Scientific and Cultural Organization (UNESCO), the gender gap in STEM-fields results from the belief that women are supposed to study certain subjects that prepare them in raising a family, while men are supposed to study a STEM degree (Grace Masanja, 2015). The first volume of the Forum for African Women Educationalists (FAWE) Research Series, asserts that one of the most common responses given by boys was that “female students are too lazy to think and work hard...”; they also mentioned the women are not able to understand, have no passion for science, and that they do not

know mathematics (Jones, 2015). According to the report of *Education from a Gender Equality Perspective* from the USAID (U.S. Agency International Development), teachers may sometimes give to male students harder tasks to complete than those given to females. Also, girls are less likely to earn a degree and pursue a career in some countries because they are supposed to maintain the house (USAID, 2015). A UNESCO paper titled *Girls in Science and Technology Education: A Study on Access, Participation, and Performance of Girls in Nepal* shows that at early school years, girls are more able to learn than boys. However, as they grow older, society expects them to spend more time completing chores than on their education (Koirala & Acharya, 2015). Many academic leaders have agreed to reach the goal of increasing the number of females and minorities in STEM programs, but that goal has not been successful. The 2012 American STEM Workforce study suggests that to increase the percentage of participants in STEM fields, and it is necessary to focus on introducing and encouraging females as well as minorities into the STEM workforce by improving the academic culture in undergraduate STEM fields to have certain groups of students, specifically females, change their field of study (American STEM Workforce, 2012). It proposes that the STEM academic culture should be more accessible, affordable, and encouraging to students so as to have them stay focused in their field of study (Suchman, 2014). Xie, Fang, & Shauman (2015) reviewed the current research on STEM education in the United States and propose there are two major components of STEM education, non-STEM general education requirements and the requisite STEM specific courses. They asserted that different social factors such as cognitive and social-psychological characteristics including family, neighborhood, school, and broader cultural levels can affect these two major components of STEM education.

The gender disparity among the students in STEM education may eventually result in a disparity within the faculty of STEM programs, thus exuberating the situation. One contributing social factor is the underrepresentation of women STEM faculty to serve as

role models and mentors to encourage female students to choose STEM fields of study. Xu (2008) examined the underrepresentation of women faculty in STEM and compared attrition and turnover rates between genders in both research and doctoral universities. The two genders did not differ in their intentions to depart from academia, but women faculty had a significantly higher likelihood to change positions within academia. According to the study, academic culture of the STEM field provides fewer opportunities, limited support, and inequity in leadership. The study suggested that the academic STEM culture needs to change in order to attract more women into these fields and narrow the current gender gap. One approach to increasing women in these fields was proposed by You (2013), namely that school districts should include an additional mathematics or science course to be taken in high school. The article presents a study done with a sample of secondary students and demonstrated that if these students took more challenging STEM field courses, they would be more likely to enroll in college and pursue a degree in a STEM field (You, 2013). Another investigation on gender and racial/ethnic disparities in STEM fields found that the physical science and engineering majors were dominated by men, specifically white men. This study also had a similar goal to increase the availability of high school preparation courses for females and minorities, which resulted in the percentage of the females majoring in a STEM field becoming closer to the percentage of men (Riegle-Crumb & King, 2010).

While additional mathematics or science courses are ideal, in some cases there is not room in a student's schedule to accommodate more coursework, and it also raises costs for schools as they have to hire additional teachers. Enrichment programs for students in developmental education is another approach to increasing STEM content knowledge and students with poor quality skills in core subjects have been shown to improve after participating in the enrichment programs. A 2012 study involving almost 7000 students further demonstrates that enrichment programs which provide additional support to students can result in improved student outcomes (Visher et al., 2012). This provides

support for the design of the TAMIU-NMTSP activities, which will help ensure student success. Summer bridge programs are also an excellent tactic colleges can implement to have a positive impact on incoming students and to assist them with building their necessary core subjects skills (Wathington et al., 2011). Improving social awareness and skills via an intervention was the approach Cerezo and McWhirter (2012) implemented with a group of Latino college students, which did aid those students to successfully build their core subject skills. This intervention can be added to the other available techniques colleges can use to assist their students to develop the skills necessary for success in STEM fields.

3. Data and analysis

The Office of Recruitment and School Relations is at the forefront of student recruitment by planning, coordinating, and implementing recruitment strategies for prospective students that aligns with the continuous enrollment growing efforts of the University and its institutional mission (<http://www.tamiu.edu/enroll/>). In addition, previous and on-going grant programs fund summer enrichment workshop activities to provide students with the background information necessary for them to choose STEM programs, whether at TAMIU or other schools. This includes the BA in mathematics with 7-12 certification program for those who want to become high school mathematics teachers upon graduation. Recruitment for female mathematics undergraduate students has consistently been significantly higher from 2006 to 2015 at TAMIU, and is clear that TAMIU has been successfully recruiting more females than males in 9 out of the last 10 years, but the same gender pattern, does not hold for mathematics graduate students, as depicted in Table 1.

Table 1. Students Enrolled in Mathematics Programs from 2006 to 2014 at TAMIU

Year	Undergraduate	Graduate
------	---------------	----------

	Female	Male	Female	Male
Fall 2015	71	52	0	8
Fall 2014	70	42	2	7
Fall 2013	65	43	4	5
Fall 2012	52	42	4	7
Fall 2011	70	61	2	10
Fall 2010	28	45	2	12
Fall 2009	69	54	2	9
Fall 2008	49	40	3	5
Fall 2007	61	45	4	4
Fall 2006	51	41	2	2

There are three undergraduate programs in math, namely BA, BA 7-12 mathematics certification, and BS. For the graduate program, there are three tracks, which are thesis, non-thesis, and non-thesis in Mathematics Education.

Focusing on only the undergraduate enrollment numbers in mathematics education, Table 2 breaks down this profile of students as reported in Fall 2015 and there are several factors taken into consideration. Students pursuing a B.A. in mathematics degree with secondary certification should be admitted by the College of Education (COED) after their sophomore year. For matriculation, students interested in programs/majors/certifications must apply to the College of Education. Admission to the College is contingent upon meeting full admission requirements, which is a separate

application process from the University's admission procedures. Acceptance to the University does not ensure acceptance into the College of Education. Students who are fully admitted to the College of Education will be eligible to enroll in 3000-4000 level education courses in their major. Full admission requirements includes: 1) Completion of all core curriculum coursework with a grade of "C" or better, 2) Completion of pre-admission courses offered by the College of Education, 3) taking two University Seminar courses (UNIV 1101 and 1102), 4) students who transfer in with 30 or more credits, 5) assessment of basic skills through exams in reading, writing, and verbal, 6) demonstration of oral and writing skills, 7) have a TAMIU GPA of 2.75, 8) Foreign language requirement, and 9) TOEFL IBT is required of all students having academic studies from a country where English is not the native language.

Table 2. Distribution of Students Based on Gender and Rank§

	Male	Female	Total
Senior	3	8	11
Junior	2	4	6
Freshman or Sophomore (Not yet Admitted to COED)	11	34	45
Total	16	46	62

§-as of Fall 2015

One of the primary recruitment tools of the TAMIU Noyce Program is a week-long Summer Boot Camp, in which participants are given stipends for attendance. The Summer Boot Camp offers students who are interested in mathematics an opportunity to participate in mathematics workshops geared towards preservice teachers, in which they complete 30 hours of activities related to mathematics, and mathematics education. The Summer Boot Camp in 2014 had 22 participants, 7 were male, while 15 were female. Of these 22 participants, 10 were our first cohort of Noyce Scholars, with the other 12

identified as potential future educators in mathematics. In the 2015 boot camp, there were 18 participants, of which 12 were TAMIU undergraduate students, three were TAMIU graduate students and three were from Laredo Community College. Of which, 8 were male participants and 10 were female participants. Students were surveyed at the end of the boot camps appreciated the benefits of the camps. The Summer Boot Camp is a first step at continuing this promising trend at TAMIU to encourage and support increasing numbers of females to becoming secondary mathematics teachers and serve as inspiration for their students to consider mathematical fields of study for their careers.

All attendees of the Summer Boot Camp and all mathematics majors are encouraged to apply for the TAMIU Noyce Program and the complete potential pool of TAMIU Noyce scholarship applicants is shown on the fourth row of Table 2, and includes those who are seeking admission, pending admission, or have been admitted to the program. The scholarship applications received and awarded appears below in Table 3, and shows that the female participation in the program is more significant than their male counterparts (Goonatilake, Lewis, Lin, & Kidd, 2014). In the first and second cohorts of the Noyce Scholarship program there were ten and six students, respectively who were awarded scholarships. Out of the first 16 awarded scholarships, 12 were female students. They have all participated in Summer Boot Camps, Fall 2015 TExES review sessions, and in the project's mentoring. When the first cohort of scholars was interviewed by the West Texas Office of Evaluation and Research in August 2015, they expressed interest in being involved in the mentoring of the new cohort of Noyce Scholars. This demonstrates the positive effects of the scholarship program on female mathematics majors. The scholars are not only personally benefiting from the program, but are also invested in helping others thrive in the program. These predominately female scholars have volunteered to be mentors, attended informal meetings to answer the new scholars' questions, and provided advice as well as helped them prepare for the content exams.

Table 3. Breakdown of Scholarship Awarded and Applications Received as of Spring 2016

	Female	Male	Total
Fall 2014	7 (11) \pm	3 (4)	10 (15)
Fall 2015	5 (9)	1 (3)	6 (12)
Spring 2016	3 (3)	1 (3)	4 (6)
Total	15 (23)	5 (10)	20 (23)

\pm - the figures in the parentheses are the number of applications received

4. Conclusions

The TAMIU Noyce Scholarship program is an ongoing effort and this paper provides a glimpse of our success in motivating female participation in the program. As the scholarship program is still in progress, its success and its long-term usefulness in increasing mathematics knowledge and increasing females choosing mathematics fields of study will require continued analysis to determine the overall effectiveness of the program. However, at this initial stage of the program, all indications are that the high rate of female participation in the program is a solid first step towards reducing the gender inequality discussed in this paper and will have a positive impact on the preparation of the teacher candidates to serve as role models for subsequent generations of students, especially female students.

5. Acknowledgements

This work was primarily supported by the National Science Foundation (NSF Award #1339993), with additional support from the TAMIU College of Arts and Sciences and the Department of Mathematics and Physics. We thank the facilitators of each part of the project for their excellent support, which is greatly appreciated. We thank Joshua Martinez and Genaro Villalobos who were involved in the initial draft of this paper.

BIBLIOGRAPHY

- AAUW (2015). Improve Girls' and Women's Opportunities in Science, Technology, Engineering, and Math. N.p.: n.p., n.d. American Association of University Women. Web. 26 Oct. 2015. <http://www.aauw.org/files/2013/02/position-on-STEM-education-111.pdf>.
- American STEM Workforce. (2012). Broadening Participation in the American STEM Workforce. (2012). *Bioscience*, 62(4), 325-326.
- Brock, Colin & Cammish, Nadine (1997). Factors Affecting Female Participation in Education in Seven Developing Countries. Second Edition. Education Research. Serial No. 9. Department for International Development, London (England). ISBN-0-861920-65-2/1997-00-00109p. Department for International Development, Education, Division, 94 Victoria Street, London SW1E 5JL, England, UK
- Cerezo, A., & McWhirter, B. (2012). A brief intervention designed to improve social awareness and skills to improve Latino college student retention. *College Student Journal*, 46(4), 867-879.
- Ellison, G. & Swanson, A., (2010). The Gender Gap in Secondary School Mathematics at High Achievement Levels: Evidence from the American Mathematics Competitions, *Journal of Economic Perspectives*, 24(2), 109–128.
- Goonatilake, R., Lewis, K.D., Lin, R. and Kidd, C.E. (2014). A Glimpse into the Effectiveness of Mentoring and Enrichment Activities for Scholarship Recipients in a Teacher Preparation Program, the *Mathematics Teaching-Research Journal Online* (<http://www.hostos.cuny.edu/mtrj/>), Vol. 7, No. 2, Winter 2014/2015, 26-35
- Grace Masanja, Verdiana (2015). "Improving Girls' Participation and Performance in Science, Mathematics and Technology-based Education." *Popularisation of Science and Technology Education* (2002): 115-43. National University of Rwanda & University Es Salaam. Web. 26 Oct. 2015. <http://www.un.org/womenwatch/daw/egm/gst_2010/Masanja-EP.8-EGM-ST.pdf>.
- Jones, Shelley Kathleen (2011). "Girls' Secondary Education in Uganda: Assessing Policy within the Women's Empowerment Framework." *Gender and Education* 23.4 (2011): 385-413. Web. 26 Oct. 2015. <http://www.fawe.org/Files/FAWE_Research_Series_Vol_I_English_-_Full_Version.pdf>.
- Koirala, Bidya Nath; Acharya, Sushan; Unesco Office Kathmandu (2015). "Girls in Science and Technology Education: A Study on Access, Participation, and Performance of Girls in Nepal." (n.d.): n. pag. UNESCO. Web. 26 Oct. 2015. <<http://unesdoc.unesco.org/images/0013/001394/139412e.pdf>>.
- Riegle-Crumb, C., & King, B. (2010). Questioning a White Male Advantage in STEM: Examining Disparities in College Major by Gender and Race/Ethnicity. *Educational Researcher*, 39(9), 656-664.

- Suchman, E. (2014). Changing academic culture to improve undergraduate STEM education. *Trends in Microbiology*, 22(12), 657-659.
- USAID (2015). USAID's Office of Women in Development by the Equate, Project, Management Systems International (Prime Contractor) (2015). This Report Was Contracted, and Under Gew-I-00-02-00021-00, Task Order #1, Equate: Achieving Equality In Educatio. EDUCATION FROM A GENDER EQUALITY PERSPECTIVE (n.d.): n. pag. U.S. Agency International Development. Web. 26 Oct. 2015.
<http://www.ungei.org/resources/files/Education_from_a_Gender_Equality_Perspective.pdf>.
- Visher, M. G., Weiss, M. J., Weissman, E., Rudd, T., & Wathington, H. D. (with Teres, J., & Fong, K.). (2012). The effects of learning communities for students in developmental education: A synthesis of findings from six colleges. New York, NY: National Center for Postsecondary Research.
- Wathington, H. D., Barnett, E. A., Weissman, E., Teres, J., Pretlow, J., & Nakanishi, A. (with Zeidenberg, M., Weiss, M. J., Black, A., Mitchell, C., & Watchen, J.) (2011). Getting ready for college: An implementation and early impacts study of eight Texas developmental summer bridge programs. New York, NY: National Center for Postsecondary Research.
- Xie, Y., Fang, M., & Shauman, K. (2015). STEM Education. *Annu. Rev. Sociol. Annual Review of Sociology*, 331-357.
- Xu, Y. (2008). Gender Disparity in STEM Disciplines: A Study of Faculty Attrition and Turnover Intentions. *Research in Higher Education Res High Educ*, 607-624.
- You, S. (2013). Gender and ethnic differences in precollege mathematics coursework related to science, technology, engineering, and mathematics (STEM) pathways. *School Effectiveness and School Improvement*, 24(1), 64-86.

Engaging elementary school students in mathematical reasoning using investigations: Example of a Bachet strategy game

Viktor Freiman

Université de Moncton, Canada

viktor.freiman@umoncton.ca

Mark Applebaum

Kaye Academic College of Education, Israel

mark@kaye.ac.il

Abstract

Strategy games are known not only as genuine tools for amusement activities, but also as efficient teaching tools used to stimulate mathematical thinking in regular classrooms and to support construction of new knowledge in situations in which students become fully engaged in meaningful learning activities with enthusiasm, curiosity and excitement. Our ongoing study aims to design and implement teaching and learning tasks based on Bachet's strategy game. In this paper we discuss the design principles and examples of students' reasoning.

Games, investigations, reasoning, engagement, elementary school mathematics

Introduction

How does one enrich students' mathematical experiences while enhancing their understanding of the complex and abstract nature of mathematics? How can the teacher engage students in building conjectures, conducting in-depth investigations, and making generalizations? How does one do this based on students' natural curiosity and their desire to learn and succeed in mathematics?

Strategy games are known not only as genuine tools for amusement activities, but also as efficient teaching tools used to stimulate mathematical thinking in regular classrooms and to support construction of new knowledge in situations in which students are fully engaged in meaningful learning activities with enthusiasm, curiosity, and excitement. Those moments of joy can also promote deeper mathematical reasoning and investigation (Cañellas, 2008).

In this article, we analyse an example of such a mathematical game that may help to evoke patterns of the culture of reasoning and proof defined by the NCTM (2000) Standards as enabling all students to 'make and investigate mathematical conjectures; develop and evaluate mathematical arguments and proofs; select and use various types of reasoning and methods of proof' (<http://standards.nctm.org/document/chapter3/reas.htm>).

Context of the study: A Bachet game

The name of the game we used in our pilot study is attributed to the French mathematician Claude Gaspar Bachet de Méziriac (1581-1638). In 1612, he published a book featuring recreational mathematical problems entitled *Problèmes plaisants et délectables qui se font par les nombres* (in this paper, we refer to its later edition, Bachet, 1884, published nearly 250 years after his death) which contains several games and riddles that later became famous and whose variations are often used today in mathematical clubs, contests and competitions, as well as in other forms of mathematical challenge and entertainment. Among them we can find the problem 'Goat, cabbage and wolf', various card games, number games (guess a number), 'false coins' games, and many others (Bachet, 1884). As a recreational problem, the game was formulated by

Bachet in French (problem number XXII from this book in the fifth edition) as follows (*English translation*):

There are two players, who take turns naming numbers that are smaller than an initial predefined number, and add to that number at each turn. The first player to reach the "destination number" is declared the winner.

This problem belongs to the 'Nim-family' of mathematical games. Piggott and Sholten (2006) consider *Nim* games as a potentially challenging and enjoyable mathematical activity that can be a resource for the development of strategic planning and reasoning as well as concepts of analogy and, through this, generalizing. Although the real origins of the game remain unknown, Delahae (2009) refers to it as being played back in ancient China; its appearance in Europe is noted in the 16th century. The name itself can be attributed to the German word 'nimm' (take) or the graphical mirror-reflection of the English word 'WIN'. Programming an algorithm of those games has become a routine exercise in computer science courses, and there are many computer programs simulating them (Delahae, 2009). These algorithms are taught at the intermediate stage of learning, as compared to more complex algorithms for other well-known strategy games such as checkers, chess, and 'go' (Delahae, 2009).

There are many versions of Bachet's game in the literature. For example, Li (2003:1) formulates it in a general way:

Initially, there are n tokens on the table, whereby $n > 0$. Two persons take turns to remove at least 1 and at most k tokens each time from the table. The last person who can remove a token wins the game. For what values of n will the first person have a winning strategy? For what values of n will the second person have a winning strategy?

The game is also used in its 'backwards' version formulated by Engel (1998: 362):
Initially, there are n tokens on the table. The set of legal moves is the set $M = \{1, 2, 3, \dots, k\}$. The winner is the one to take the last token. Find the losing positions.

In our paper, we use a simplified version of this latter form, with rules that can be adapted to students of all ages and abilities, to potentially engage them in meaningful

mathematical investigations. In so doing, we help them apply genuine mathematical thinking, making new conjectures, discussing, proving or disproving them and building new inquiries, thus differentiating the level of challenge, creating new games and then posing and solving new mathematical problems. Our ongoing study is divided into two steps, or objectives:

- (1) Develop a teaching-learning scenario integrating mathematical investigation of the game and validate it with elementary school students and teachers (professional development and initial training);
- (2) Develop research tools that enable studying patterns of mathematical thinking and reasoning emerging from students' investigations, experimenting with them in a classroom, and testing them as a case study.

In the following sections we briefly present our theoretical view, a scenario experimented on with one group of students and preliminary findings from the students' questionnaires.

Theoretical background: Educational potential of investigations with strategy games

Alro and Skovsmose (2004) stress the view of learning as an action which creates possibilities for investigations. Yerushalmy, Chazan and Gordon (1990), Leikin (2004), and Applebaum and Samovol (2002) emphasized the importance of instructional inquiry activities to develop more creative ways of learning, thus nurturing interest in a particular area and continuous motivation to learn more about it. In addition, students' willingness to choose problems to investigate, to design methods to explore them, and then attempt to generate the solutions can be facilitated. While designing tasks with the Bachet game, we draw on the works of Peressini and Knuth (2000) and Sheffield (2003) who suggest using rich tasks that promote open-ended investigations, allow several different approaches, are non-standard, focus on higher-order abilities, ensure interaction of practical and

theoretical thinking as an important element in the process of transition to more complex and abstract mathematical ideas like algebra.

Use of mathematical games in teaching and learning is described by a number of authors as favorable for fostering discussion between students (Olfield, 1991), enabling them to discover new mathematical concepts and develop thinking abilities ((Baek et al., 2008; Bragg, 2007). As an educational activity, each game contains an intriguing element that motivates children to play and explore rules and outcomes. Related mathematical content is uncovered in the process of playing and eventually posing a challenge of finding a better, (winning strategy. In this process of meaningful mathematical investigation, students can be further guided towards building models, testing, discussing, promoting hypotheses, posing new problems and refining them.

In their study of teachers' behavior that promotes mathematical reasoning, Diezmann, Watters, and English (2002) noticed that 'young children's reasoning can be enhanced or inhibited by teachers' behavior through their discourse, the type of support they provide for their class, and how they implement mathematical tasks'.

By designing and implementing investigative tasks with the Bachet game, we aimed to model such kinds of behavior and make explicit the elements of mathematical reasoning that emerge under these conditions. Since the study is on-going research, at this stage we discuss preliminary observations from the field notes and the students' questionnaires.

Methods of inquiry: Design and validation of the teaching and learning scenario

Related to our first and second objective, in order to study the emergence of mathematical reasoning by investigation of the Bachet game, we designed a teaching and learning scenario that has been implemented with several groups of pre-service and in-service teachers and elementary school students (Grades 2-5) in Israel and Canada (New Brunswick). To construct a learning activity with Bachet's game we used the following

teaching - learning cycle of mathematical investigation suggested by Applebaum and Samovol (2002).

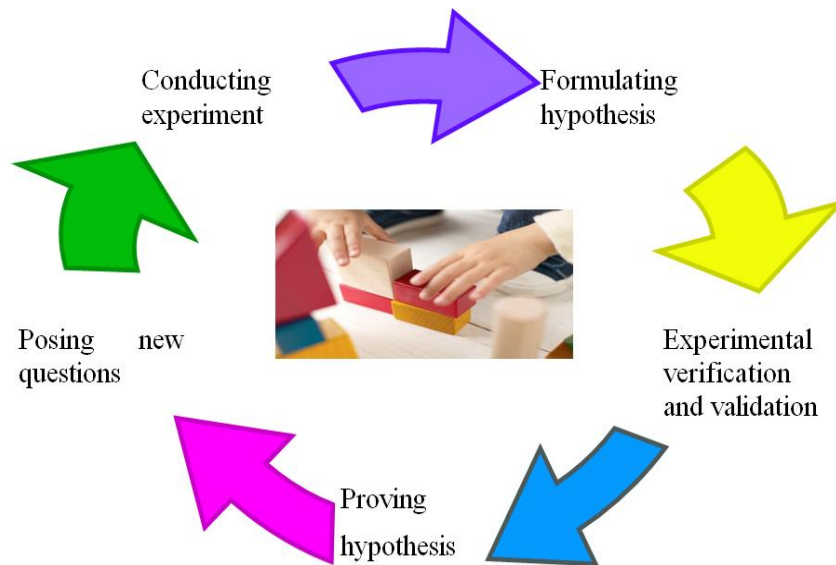

In this scheme, we see how students gradually become engaged in mathematical investigations through the game: posing questions, conducting experiments, formulating hypotheses, verifying and validating, proving, and formulating new questions for further investigations, thus launching a new learning cycle.

Initial steps

Each session starts with an explanation of the rules of a simplified version (compared to the one in Bachet's book). The game starts with placing 15 tokens on the table. Then, two players (or groups of players) make their moves, at each one's turn, according to the following rules: The first player (or team) begins by removing one, two or three tokens, the second player (or team) removes one, two or three tokens; then the game continues with each player (or team) taking turns. The player who picks up the last token left on the table is the loser of the game. Usually, we play a couple of times with the whole class to make sure participants understand the rules, but not to give any advice or prompting on how to play. In all settings and with all audiences (students and teachers), the rules of the

game were understood by every participant after 2-3 rounds of such collective play. While trying out the game by playing it in dyads, participants were asked to make a number of initial observations which they then shared with their colleagues and peers in an all-group discussion. Here are some examples of the comments they shared: ‘I just copy all the moves my partner (opponent) makes and often win’; ‘Each time I play I use a different strategy’; ‘I see that each time I leave my ‘partner’ (opponent) with 5 tokens I win’; ‘I always take 2 tokens off and win’.

We can see that whereas some of the observations took the form of reflection on the results of the game (who won – ‘I always won’), others showed a focus on strategy (how to play better in order to win – ‘I always took two at each turn and won most of the games’). Since our task as facilitators of the activity was simply taking notes from the participants' discourse and writing them on the board, we were able to notice several things. For example, we observed some spontaneous questioning initiated by participants (e.g., ‘what number of tokens should I have in order to win?’); argumentation (e.g., ‘no, you are not right by saying that the person who starts always wins. I started twice, and in both cases I lost.’); or even providing proof (e.g., ‘I noticed that in the case of 6 tokens, I could always take 1 and leave my opponent with 5 tokens, so he would lose every time.’). The general observation at this stage (regardless of the age and type of audience) was that the most plausible conjectures are related to a situation in which few tokens are left (3 – 4 – 5 – 6), so the end of the game becomes ‘calculable’. After this initial discussion, students return to playing in dyads, but this time they are explicitly asked to verify the list of observations or conjectures written on the board and, eventually, others they may wish to add to this list. For mathematical reasoning to occur, the process of verifying (and eventually, proving or disproving initial observations/ conjectures) is very important. A good understanding of the ‘5-case’ (player left with five tokens will lose in any possible case) is an example of such an opportunity that emerges in all groups we led. While construction of the ‘proof’ seems to be possible by students who Sheffield (1999) would

call ‘mathematically promising’, presenting it and validating it with the rest of the class is an essential step for all participants – i.e., the ‘new’ knowledge is constructed, debated, shared, and validated at the highest level of motivation to learn the ‘winning strategy’.

Proving and disproving conjectures: Fostering exploration and questioning

Hence, by working in dyads, and discussing their findings, students become engaged in more active exploration which would implicitly involve some conjecturing and validation. The first attempts in proving (disproving) emerge spontaneously. Some students may explain why **5 tokens left** by their partner ensure them a win.

The next round of classroom discussion may lead to more formal proofs, by looking at all possible combinations with 5 tokens:

If you remove 1 token, I will remove 3, and so you are left with one and lose.

If you remove 2 tokens, I will remove 2, and so you are left with one and lose.

If you remove 3 tokens, I will remove 1, and so you are left with one and lose.

There are no other options, so you will lose in all cases.

It is also important to have at least one conjecture being disproved like ‘repeating the same move as my partner causes me to win’. The next example illustrates the case for which the conjecture does not hold:

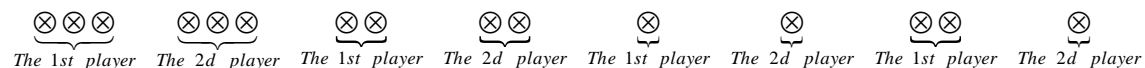

The second player repeated the same move as his partner and lost the game. A follow-up discussion can lead students to the understanding that one single case is sufficient to disprove the statement and eventually to a deeper comprehension of the logic behind proving and disproving conjectures.

By all means, it is important to make students realize that from 6 – 7 – 8 left token configurations, the player who starts can win by generating a ‘**5 tokens left**’ case. This moment of realization is important in order to boost further investigation that would lead students to discover other winning numbers – ‘**9 tokens left**’ and ‘**13 tokens left**’ and eventually to prove that in the initial situation, the player who starts first can remove 2 tokens (to reach the ‘**13 tokens left**’ position) and let the second player choose whatever tokens he/she wants and then complete it to ‘4’ tokens (second player gets 1 – first player gets 3; second player gets 2 – first player gets 2; or second player gets 3 – first player gets 1) and bring it to ‘**13 – 9 – 5 – 1 tokens left**’ pattern.

The next diagram presents an example of possible moves:

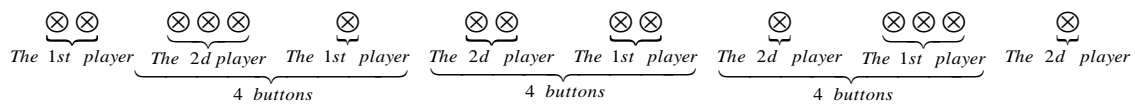

Studying the ‘4’ pattern here is an important step in moving towards reasoning and generalizations in a purer mathematical way.

It is very important to guide the students to the comprehension of the idea that the ‘4’ pattern does not appear randomly, but has to be obtained as a sum of 3 (the maximum number of tokens that can be taken) and 1 (the minimum number of tokens that can be taken). An explanation for this can be the following: we need a constant total number of tokens at each move to maintain control over the game. In this game, 4 is the unique total of tokens at each move that gives the first player a full control over the game's development and its (winning in *all* cases) outcome. Other numbers, for example, 5 cannot guarantee the same outcome. The reason is: if your partner takes only one token, you will not be able to complete the sum up to 5. Number 3 does not work for the same reason : if the first player takes 3 tokens, the second player has no way to complete to 3.

Prompting Further Investigations

Once the game with 15 tokens is well mastered by students it is important to bring them to further questioning about the rules. For example, students or the teacher can suggest changing the number of tokens, and seeing what happens if the number of tokens is 20 (or any other number larger than 15). It is plausible to anticipate that students will try to apply the same (or a similar) strategy and eventually come up with the solution (by going from the end to the beginning). For further generalization of the findings it might be interesting to ask students they think what would happen with 200 tokens; thus encouraging them to move towards more abstract mathematical exploration and eventually helping them to discover mathematical formula to model the game.

It might also be interesting to ask students to make their own rules and investigate strategies for newly created games or challenge their classmates to investigate. Here are some innovative ideas that may emerge:

- (a) The players may choose 1, 2, 3 or 4 tokens at each turn,
- (b) A player who gets the last token is the winner.

To make the investigation even deeper and eventually more interesting for students with higher mathematical abilities, the following questions may be helpful:

- (1) Could you suggest a case in which the player who is first to take tokens will lose the game, when the number of tokens is more than 20 and students can take 1,2,3,4 or 5 tokens on each turn? (Both players know the winning-strategy as well and the player that gets the last token loses the game)
- (2) Two players Dan and Sam know the winning-strategy of this game. Dan is the first player and he should decide how many tokens: 28, 29 or 30 will be on the table. Sam is the second player and he should decide about the maximal number of tokens that may be taken in each turn: 6, 7 or 8 (you can take 1-6, 1-7 or 1-8 tokens). Who will win this game?

- (3) Two players Kate and Carole know the winning-strategy of this game. Kate has the right to decide if she wants to be a first player. As first player she can state how many tokens will be on the table: 43,45,47,49 or 51. Then Carole as the second player will choose the maximal number of tokens to be taken in each turn: 7,8,9 or 10. If Kate decides to be the first player, who will win this game?

Finally, for some very advanced students, investigations can be enriched by moving to any number of tokens:

Investigation 1

There are N ($N > 20$) tokens placed on the table. The game is for two players. The players may take 1, 2 or 3 tokens. The player who is left with the last token loses the game. How can we know who will win this game?

Explanation: To win this game you have to take the $(N-1)$ -th token. How can we guarantee taking the $(N-1)$ -th token? We have to take the $(N-5)$ -th token! And then we'll take the $(N-9)$ -th token, and so on... Now if we get 1, 2 or 3 tokens at the end of the process, the first player can win the game by using the strategy we described above. If we get 0, then the first player will lose the game.

First step to generalization

First of all we have to reduce the number of all tokens by one: $(N-1)$. Then we'll divide $(N-1)$ by 4 (remember: $4=3+1$). If we get a remainder (1, 2 or 3) then the result of the game depends only on the first player; if he uses the win strategy (completing to 4), he will win this game. If we do not get a remainder, then the second player can win this game using the strategy we revealed above.

Solving the next two questions may help students gain a deeper understanding of Investigation 1.

Question1: There are 47 tokens on the table and two players that are playing this game.

As in previous cases, they can take, by turns, 1, 2, 3,... k tokens ($5 < k < 20$). It is known

that the first player is going to lose the game (both players know the winning strategy).
Find the possible k value.

Question 2: There are 62 tokens on the table and two players that are playing this game. As in previous cases, they can take, by turns 1, 2, 3, ..., k tokens ($5 < k < 20$). It is known that the second player is going to lose the game (both players know the winning strategy). Find the possible k value.

Investigation 2

There are N tokens placed on the table. The game is for two players. The players may take 1, 2, 3, ..., or k ($2 < k < \frac{N}{2}$) tokens. The player who is left with the last token loses the game. What is the winning strategy?

Explanation: First of all, we need (as in Investigation 1) to reduce the number of all tokens by one: $(N-1)$. Then we'll divide $(N-1)$ by $(k+1)$. If we get a remainder (1, 2, 3... or k) then the result of the game depends only on the first player, and he can win this game. If we does not get a remainder then the second player can win this game by using the already well-known strategy. We can write:

$$\frac{N-1}{k+1} = \begin{cases} \text{whole number} \rightarrow \text{the second player is the winner} \\ \text{some remainder} \rightarrow \text{the first player is the winner} \end{cases}$$

In order to win a player needs to take the number of tokens that completes to $k+1$ the number of tokens that had been taken by the other player.

CASE STUDY with grade 5 students and their teacher: Classroom setting for the activity and research tools employed

In order to meet our second objective and thus gain more insight into students' 'laboratory of thought' during the investigation of the game, at the second stage of our study we developed a questionnaire asking students to share their ideas and perceptions. Our first data come from an experiment conducted with two groups of 5th grade students (a total of 88 students, 10-11 years old) in an Israeli elementary school. The activity was organized at the end of the school year.

According to national external exams (Ministry of Education) the school is in the top 10% of all Israeli schools. The groups of students participating in our activity had the same mathematics teacher from the 3rd grade and up till the time of the experiment. The average marks in the two groups were: 80 and 83. According to the teacher, there were no students with behavioral problems in these groups.

Regarding the mathematical background of our participants, the teacher informed us that until the time of the experiment, while following the regular curriculum, students had learnt the following topics: integers and the 4 arithmetic operations with them, and addition and subtraction of fractions. During the school year, the teacher had frequently integrated problems oriented towards developing mathematical thinking in her lessons. In addition to the regular curriculum, mathematically promising students received one lesson per week, over the course of 3 months, which dealt with solving non-standard problems.

According to the teacher, mathematical investigation of a strategy game framed within a scenario similar to the one we developed with Bachet's game was relatively new to our participants. The teacher said that sometimes she opened her lessons with a math game or puzzle. But it was usually of rather a small scope and a short activity compared to the one we suggested to the students. According to the teacher's observation, the end of the school year was not the ideal time for this kind of activity since the children's motivation for any kind of intellectual work was rather low; however, most of the students participated and they seemed to have fun. Some of the students were challenged by the game and activated deep thinking that led them to discover some form of strategy. Others

just "played the game" for game's sake and also enjoyed it. As suggested in our scenario, students had to explore the game on their own with minimum guidance from their teacher.

Analysis of Questionnaires

While playing in dyads, students made several observations and produced protocols of the game rounds. Although, only one student in each dyad filled-in the questionnaire (as we mentioned above, in total we collected 44 questionnaires). The first part of the questionnaire asked about students' perceptions of mathematics, of learning mathematics, of lessons in general, and playing the game in particular. The following table summarizes data for each item (including mean and standard deviation based on the 4-point Likert scale: ranging from 1- completely disagree up to 4 – completely agree).

Item	Mean	Standard deviation
I like to solve new math problems.	2.89	.97
I solve Math problems easily.	2.84	.78
Math is important to me and useful in everyday life.	3.74	.57
My motivation to learn Math increased after playing this game.	2.87	.94
I would recommend learning through games to my friends.	3.3	.73
When playing this game I learnt new ways of problem solving.	3.17	.94
I enjoyed playing this game.	3.68	.66
I'm active during Math lessons.	3.23	.63
My success in Math depends only on my effort.	3.68	.75
I always prepare my homework in Math.	3.38	.77
I like to solve Math tasks.	2.87	.90
I have anxiety during Math tests.	1.91	1.04
I'm interested in Math.	3.26	.79
I'm successful in Math.	3.15	.83
I enjoy Math lessons.	3.23	.70

As we learn from the data, almost all students seem to agree that math is important to them and useful in everyday life ($M=3.74$). Furthermore, they believe that their success in math depends only on their own effort ($M=3.68$). The majority of students are interested in math ($M=3.26$), active in math lessons ($M=3.23$) and enjoy them ($M=3.23$). They always do their homework ($M=3.38$), do not have anxiety during math tests ($M=1.91$), and seem to be quite successful in math ($M=3.15$). Regarding the question regarding their experience with problem solving, the opinions seem to be more diverse, although many students agree that they like to solve math tasks (2.87), including new problems ($M=2.89$) and also claim to solve problems easily ($M=2.84$).

Regarding students' experience with the game, they almost unanimously confirm having enjoyed the game ($M=3.68$); and many generally affirm having learnt new ways to solve math problems ($M=3.17$). Although their opinions on the role of the activity in increasing their motivation to learn math ($M=2.87$) are more diverse, the majority would recommend it to their friends ($M=3.3$).

The second part of the questionnaire was related to reflection about the game and to reporting students' observations and discoveries. More specifically, there were questions related to the initial observations while playing in dyads (conjecturing). Students were asked to note whether the winner had played well and why.

Another set of questions was based on conjectures made, and their investigation was recorded in the form of a table in which children note the number of the move, number of tokens taken by the 1st player, number of tokens taken by the 2nd player, and total of tokens taken at each move. Examples of two recorded games are given [in Hebrew] in the Figure 1 below.

Number of tokens taken by both players	Number of tokens taken by player 2	Number of tokens taken by player 1	Number of each move
2	1	1	1
5	3	2	2
3	2	1	3
4	1	3	4
	1		5
			6
			7
			8

Number of tokens taken by both players	Number of tokens taken by player 2	Number of tokens taken by player 1	Number of each move
4	1	3	1
3	1	2	2
4	1	3	3
4	1	3	4
			5
			6
			7
			8

Figure 1. Example of protocols of two students: The right column shows the number of each move, then (from right to left) we have: number of tokens taken by player 1, number of tokens taken by player 2, and (left column) number of tokens taken by both players at each move.

From our analysis of the questionnaires, we learned that in 14 of the 44 dyads (31.82%), the children were able to find that leaving the partner with 5 tokens is a winning strategy (this is actually the first step in discovering such a strategy).

In 37 of the 44 dyads (84.09%), students who got the 10th token won the game. It is clear that it could not be coincidental and students directed themselves to getting the 10th token. In 14 out of 37 cases (37.84%) students that got the 10th token (or 5th token, if counted backwards), also won the game and described the winning strategy. In 23 out of 37 cases (62.16%) students that got the 10th token (5th token, if counted backwards), and won the game were not able to draw conclusions or describe the winning strategy. A number of metacognitive comments made by students about their way of thinking and reasoning seem to indicate their appreciation of the task as thought provoking. The following table (Table 1) presents categories that emerged from students' responses and corresponding quotations.

Table 1. Categories emerging from students' observations

Category	Examples of students' responses
Promoting thinking	'I liked the fact that I needed to think a lot in this game.'
Combining joy and learning	I liked this game because I enjoyed playing and studying at the same time; 'when we enjoy it we learn in an effective way.'
Need to search for the winning	'I had to look for ways to win using different

strategy	strategies.’
New mathematics learning opportunities for students	‘I learnt to think with logic and to find patterns.’
Making discoveries and investigating them	‘I make sure that by the end of the game I will have 5 tokens left, and then it does not matter how many he [my opponent] gets, I’ll win anyway’; ‘It worked exactly as I thought.’
Opportunity to ask new questions	‘Will the number of tokens influence the game? Will the number of players influence the game?’

Overall, we found that students perceive the game as an enjoyable learning experience that makes them think in an attempt to find a winning strategy, as they need to apply logic and look for patterns, an ability particularly well-demonstrated by mathematically promising students (Sheffield, 1999). Few students go beyond these first steps of reasoning by conducting deeper investigations and asking new questions; this is a culture of mathematical proving yet to be developed in the classroom (Bieda, 2010).

We also asked students to predict and explain whether 8 rows in the form (which is equivalent to the maximum number of moves) would be sufficient to complete any round of the game. By asking this question, we solicited some reasoning based on the total number of tokens (15) and the number of players involved at each move (2). Almost all students gave an affirmative answer, but only 12 of the 44 dyads (27.28%) were able to explain their answer in a more or less plausible way. Table 2 represents five different patterns found in students’ responses.

Table 2. Students’ reasoning about the structure of the game

Students’ statements	Our remarks
Even if each player gets one token, 7 rows will be sufficient to complete the round of the game	The student seems to understand the structure of the game and condition of looking for a maximum number of possible steps. She probably anticipates the situation in which the last remaining token would not require a move – so to her, the game stops after 7 moves (rows).
8 is a little bit more than we need.	This student did not provide the details of her definition of ‘a little bit’ but may also get a sense of 7 rows needed and then 1 token would be left over.

8 rows are enough because we have 15 tokens and only 2 players.	In this effort of a plausible explanation, the student seems to omit the explanation that this situation would happen if every player took 1- the minimal number of tokens at each move.
If each player takes only one token we'll need only 7 and a half rows.	Interesting explanation with the student interpreting the record of her last move as "a half row" – question of making a distinction between the structure of the table (row) and its content (the need to fill in a complete row to count it as a 'row').
The answer is "yes", because in both games we played we needed only 3 rows.	Incorrect attempt to generalize based on an insufficient number of examples; no reasoning is provided.

Discussion and Conclusion

While recent mathematics curricula place great emphasis on the development of mathematical reasoning in all students, the optimal teaching and learning conditions to foster this reasoning is not yet known. Our ongoing study explores the potential of recreational mathematics, in general, and strategy games, such as Nim, in particular, which shed light on how to build learning and teaching scenarios which prompt investigations of patterns that emerge during the game. Issues of their implementation in the classroom, as well as studying their ultimate impact on students' learning were also examined. As a case study, we used a "Bachet's game" which we presented to teachers and students in a way in which clear and simple rules hold nearly infinite potential for students to make observations, conjecture, verify, explain, and ask new questions while playing. The entire process potentially leads to the development of high-level reasoning abilities even in young students in elementary school. The students participated in our study, in the context of a strategy game, in a similar way to that discussed in previous studies, e.g., Piggot and Sholten (2006), Diezmann et al. (2002), and Sheffield (1999), showed a high level of engagement and task commitment. The latter was accompanied with 'continual attempts to make sense of their actions and discourse, and challenges for their peers to do likewise' (Piggot and Sholten, 2006). Similar observations were also noted by Civil (2002) while investigating Nim-like games with her Grade 5 students by

involving students in the exploration of mathematical principles behind the game; she found students engaged, appearing to enjoy themselves, and persistent. At the same time, the author noticed that while (almost) all students showed initial enthusiasm about the game and curiosity in finding the winning strategy, few of them were actively involved in mathematical analysis (Civil, 2002). The same situation was also observed in our case study, with only a small number of questionnaires providing a clear explanation of the winning strategy and a justification for the number of moves needed, so the question of ‘bridging’ students’ overall excitement with meaningful mathematical reasoning is still an open question that requires more research and teaching practice. Moreover, in our study we had to comply with a short time-period given to the students to conduct investigations, which is a clear limitation of our study. While promoting investigations with a strategy game, which can also be considered to be an open-ended problem, teachers may face difficulty in explicitly suiting the task (open-ended) of investigating patterns to the school curriculum and learning outcomes. This issue was also brought up by a teacher who said that focusing on specific content and tasks suggested by curriculum places additional pressure on her, although she does see multiple benefits of deeper learning that can be enhanced by strategy games.

Looking back on our scenario may help to uncover potential pitfalls when guiding students through investigative tasks; some were already mentioned in earlier studies, like the one conducted by Henningsen and Stein (1997). In their study, which focused on geometry, students’ failure to engage in the intended high-level cognitive processes was attributed to a number of factors, such as lack of clarity and specificity of the task expectations which were not specific enough to guide students toward discovering the relevant mathematical properties; another example, the lack of prior knowledge needed to make effective comparisons and differentiations, was already mentioned as a factor that could potentially hinder students’ efforts to systematically record and generalize their findings (Henningsen and Stein, 1997).

The teachers' readiness to support students' deeper thinking through mindful and purposeful scaffolding is also important, as noted by McCosker and Diezmann (2009) who argue for pressing students to provide meaningful explanations, working from students' ideas, distinguishing positive encouragement and cognitive scaffolding, as well as providing students with unambiguous task instructions and clear expectations, while ensuring that the investigation remains open-ended in the form of teachers' strategies that enhance reasoning. Our other publication, addressed specifically to teachers, also illustrates the benefits of this approach (Applebaum and Freiman, 2014).

Overall, our preliminary results indicate promising paths in fostering mathematical reasoning in young children using strategy games that need to be studied in more depth. In the next stage of this research, we plan to continue working with teachers and collecting data in order to gain more insight into the impact of such activities on students' motivation and performance in learning mathematics. We also seek to explore how these activities may be used by more teachers in a more efficient way.

References

- Alrø, H., & Skovsmose, O. (2004). Dialogic learning in collaborative investigation. *Nordisk Matematikk Didaktikk*, 9(2), 20-62.
- Applebaum, M. V., & Samovol, P.I. (2002). Teaching Mathematics Using the Idea of "Research problems". *Proc. of the 2nd International Conference on the Teaching Mathematics (at the undergraduate level)*, University of Crete, Hersonissos, Crete, Greece, 2002.
- Applebaum, M., & Freiman, V. (2014). Use of Recreational Mathematics in the classroom: example of Bachet's game. *Mathematics Teaching Journal*, Vol. 241, 22-26.
- Bachet, G. (1884). *Problèmes plaisants* (in French, 5th Edition). Paris.

- Bieda, K. (2010). Enacting proof in middle school mathematics: Challenges and opportunities. *Journal for Research in Mathematics Education*, 41, 351-382.
- Bragg, L. (2007). Students' conflicting attitudes towards games as a vehicle for learning mathematics: A methodological dilemma. *Mathematics Education Research Journal*, 19(1), 29-44.
- Cañellas, L. (2008). The use of strategy games favors learning of functional dependencies for de-motivated students. In: B. Czarnocha (Ed.) *Handbook of Mathematics Teaching Research: Teaching Experiment - A Tool for Teacher-Researchers*, University of Rzeszów.
- Civil, M. (2002). Everyday Mathematics, Mathematicians' Mathematics, and School Mathematics: Can we bring them together? (pp. 40-62) *Journal for Research in Mathematics Education. Monograph, Vol. 11, Everyday and Academic Mathematics in the Classroom*. NCTM.
- Delahaye, J.-P. (2009). Stratégies magiques au pays de Nim. *Pour la Science*, 377, retrieved on April, 27th, 2014, from http://www.pourlascience.fr/ewb_pages/a/article-strategies-magiques-au-pays-de-nim-19846.php
- Diezmann, C. M., Watters, J. J., & English, L. D.(2002). Teacher behaviours that influence young children's reasoning. In A. D. Cockburn, and E. Nardi (Eds). *Proceedings of the 27th Annual Conference of the International Group for the Psychology of Mathematics Education* (Vol. 2, pp. 289-296). Norwich, UK.
- Henningsen, M., & Stein, M. (1997). Mathematical Tasks and Student Cognition: Classroom-Based Factors That Support and Inhibit High-Level Mathematical Thinking and Reasoning. *Journal of Research in Mathematics Education*, 28(5), 524-549.
- Leikin, R. (2004). Towards High Quality Geometrical Tasks: Reformulation of a Proof Problem. In M. J. Hoines & A. B. Fuglestad (Eds.). *Proceedings of the 28th International Conference for the Psychology of Mathematics Education* (Vol. 3, pp. 209-216). Bergen, Norway.

- McCosker, N. and Diezmann, C. M. (2009). Scaffolding Students' Thinking in Mathematical Investigations. *Australian Primary Mathematics Classroom*, 14(3), 27-32.
- Oldfield, B. (1991). Games in the learning of mathematics, *Mathematics in Schools*, January, 1991.
- Peressini D., & Knuth, E. (2000). The role of tasks in developing communities of mathematical inquiry. *Teaching Children Mathematics*, 6(6),391-397.
- Piggott, J., & Sholten, J. (2006). Games related to Nim. Retrieved on 16th of February, 2014 from <http://nrich.maths.org/>.
- Sheffield, L. (1999). Serving the Needs of the Mathematically Promising. In L. Sheffield (Ed.), *Developing Mathematically Promising Students* (pp. 43-56). NCTM.
- Sheffield, L. (2003). Extending the Challenge in Mathematics: Developing Mathematical Promise in K-8 Students. Corwin Press & Texas Association for Gifted and Talented.
- Yerushalmy, M., Chazan, D., & Gordon, M. (1990). Mathematical problem posing: Implications for facilitating student inquiry in classrooms. *Instructional Science*, 19, 219-245.

Mathematical Curriculum, Mathematical Competencies and Critical Thinking

Dieter Schott

dieter.schott@hs-wismar.de

Hochschule Wismar, University of applied sciences technology, business and design
Wismar, Germany

ABSTRACT

A different view is given to mathematical curriculum by stressing competencies in mathematical education. Critical thinking is a very general competency which is an inherent part of mathematical and scientific thinking but which is also useful to analyze statements and events in everyday life. So mathematical education can not only contribute to problem solving in science and engineering or to an intellectual personality but also to making processes in society more transparent and to exposing dubious arguments and interests.

The paper presents some examples showing the interplay of mathematical curriculum, mathematical competencies, critical thinking and everyday life.

INTRODUCTION

In Germany, and also in other countries worldwide, the relation between mathematical knowledge and mathematical competencies within the educational process is controversially discussed. Indeed, there is a close connection between both concepts. Knowledge should create competencies and competences reflect on knowledge. The new trend of stressing competencies at least gives the opportunity to investigate this relation deeply, to make it conscious for the public and to draw fruitful consequences for mathematical education. But, some new prophets overemphasize competencies in such a way that bloodless and spongy categories (with empty or poor content) are left at the end of the educational process.

The mathematical curriculum considers content which is necessary to solve important problems and to understand other important parts of mathematics and their interplay. At the engineering faculty of Hochschule Wismar this curriculum is based on *Linear Algebra* (vector and matrix

concept), *Analysis* (calculus and differential equations), *Numerical Mathematics* (approximate methods, algorithmic thinking, error estimation, time and storage effort) and *Stochastics* (probability concept, distributions, conclusions from random samples). Critical thinking is trained based on logical thinking, on precision, on error estimation and on completeness of arguments. Besides, *paradoxes* and *counterexamples* in Mathematics are especially suitable to train such competences as critical thinking. Often they occur in the educational process as challenges of thinking. Paradoxes can play a very useful role by producing fruitful discussions, provoking deeper thinking about the subject, clarifying new concepts and giving better insight to the theory. So they can help removing potential conflicts between intuition, theory and reality [1], [7].

Finally, modern trends in education as *modelling* and *simulation*, use of *software* and *internet* sources as well as project work in teams are integrated to solve also more complex scientific or applied problems.

Often certain formulas measuring or relating quantities of interest are given in the public. Some of these formulas can be analysed by using basic mathematical means whether they are of more or less practical value, which modelling assumptions are hidden behind and which features are neglected by the model. Sometimes some specialists try to award a discipline more importance by creating useless mathematical formulas. This is called *pseudo-mathematisation*. Further, some interesting news containing mathematically looking data are presented in the media. Mathematically educated people as engineers should be able to decide if these data are seriously used or if they serve more or less ideological and personal interests, respectively. This is often not clear at the first view and needs some investigation.

The topic is already outlined in paper [6] with some other priorities. The paper [5] gives some insight into the interaction between mathematics and engineering concerning the development of competencies. The calculation of support forces in engineering mechanics corresponds to the solution of systems of linear equations. Support forces turn out to be statically determinate if and only if there is a unique solution of the corresponding linear system. Hence, the experience of engineers is backed by a clear mathematical criterion supplying a deeper understanding. Mathematics can play a similar part also in other disciplines and in everyday life.

CURRICULUM AND COMPETENCE

In earlier times the curriculum was the most important educational base. The contents and its volume were fixed for different study courses and different levels. Later a catalogue of learning aims was added. At the end of a curriculum section the learners should be able to solve fixed problems. Nowadays the competence model is the most favorite one. It has become a vogue word. It describes abilities and skills which are needed for a qualification, e.g. as Bachelor or Master in a certain engineering subject. There is more freedom for lecturers to fix contents and methods for acquiring of prescribed competencies. Besides, the ability for further study and the solution of everyday problems are included. Hence, the courses are also application oriented. Besides, there are methods to measure the quality development in learning processes. But, the definition of competencies is often rather vague and open for different interpretations. Finally, also the international discussion is rather broad. So the concept is used in most cases intuitively. Essential general mathematical competencies are:

- Use of *knowledge*: understanding mathematical theory, knowing important facts, linking between disciplines;
- Correct use of *technical elements*: mathematical language, logical reasoning, rearranging or transforming of terms, use of means as tables, formulas, computer software and media;
- *Problem solving*: applying and transferring solution methods, applying heuristic methods, generalizing, creating new connections and concepts;
- Use of *Methodology*: algorithmic, numerical, analytical and stochastic thinking, geometrical imagination;
- *Mathematical modelling*: creating suitable models, interpreting and validating results;
- *Critical thinking*: checking correctness and completeness of results;
- *Communication skills*: team working, networking.

These competencies are also developed in our mathematical curricula at Hochschule Wismar. The nomination of competencies allows drawing links between subjects and competencies. Unfortunately, for all our efforts, many students can only solve problems mechanically following given algorithms. The introduction of new teaching methods can not eliminate this phenomenon, although some experts in didactics insist to claim that.

PSEUDO-MATHEMATICS

There are different roots for applying mathematics in a wrong way:

- Mysticism, giving subjects a curious mathematical meaning;
- Naivety, missing competence in the sphere of application;
- Use of mathematical models without checking the model assumptions;
- Mathematical modelling in a sphere not yet prepared for (*Quételet*: Social Physics [4], *Fechner*: Psycho-Physics [3]);
- Trickery, upgrading a subject by linking to mathematics;
- Rationalism (Mathematics is behind all things);
- Propaganda (ideology, interests), using mathematics to influence persons in a certain direction.

Nevertheless the book [4] of *Quételet* (1869) is considered as a starting point and milestone for the quantitative analysis of human and social qualities. According to the book [3] the work of *Fechner* is also well estimated as the beginning of a new era in psychology. Although the legitimacy of mathematics in natural sciences is recognised, the applications of mathematics in social sciences and economy are often discussed controversial. The complexity in society is very high and of another quality as in nature. The models are often either too simple or uncritically transferred from other fields. The consequences of pseudo-mathematics are double-edged. A lot of people believe at the omnipotence of mathematical formulas and models and feel helpless because mathematical power seems to dictate the world. Other people mistake mathematics as an elite discipline with no or only little value for the general public.

MODELING

Often simple models are used in everyday life. If the applications are successful some people do not think at Mathematics at all and some others believe that Mathematics regulates the world. In any case, they take the success for granted. But what happens, if the result turns out to be wrong. Then people often blame Mathematics for the disaster. They do not realize the true causes for misleading results:

- The model is too simple for the given facts.
- The model is given a wrong meaning.
- The range of application is not observed. Prerequisites of the model are ignored.
- The model is used in a new context (without proving the legitimacy).

In everyday life the problems are not uniquely given. It is necessary to see problems and to formulate them adequately in a mathematical model. There are a lot of possibilities to create such models. The art is to find a sufficiently simple one which is good enough for successful applications.

Modelling in science or engineering shows that there is a gap between models and reality. Models can replace parts of reality under certain conditions. Models show then a similar behaviour as real systems. Often models have only a restricted range of application which has to be known and observed to get reasonable results. Models which hold under some conditions have to be replaced by more general models if these conditions are violated. Sometimes these more general models are already known; sometimes they still have to be found. E.g., the simple linear differential equation

$$x'(t) = c \cdot x(t) \quad (1a)$$

of first order describes exponential growth of a population or a process. Indeed such a model is realistic if there are enough resources for a completely free development (bacteria, certain time intervals of growth processes). The British scientist *Robert Malthus* assumed such a model for the human population and predicted a catastrophe on earth (1798). In the meantime it is known that limited resources slow down the

growth of a population. *Verhulst* proposed a new model with a self-limitation for large populations (bounded carrying capacity, 1838):

$$x'(t) = c \cdot x - d \cdot x^2 \quad (c > 0, d > 0) \quad (1b)$$

The negative second term on the right side of the so-called logistic differential equation reduces the growth to a certain limit. This equation is also of first order, but nonlinear. For $d=0$ the old model (1a) arises. Since the logistic model was successfully applied to a lot of growth processes in nature and economy some people believed that there is a logistic principle in the world. But a lot of other models with restricted growths were found considering also the age process in a population or other additional parameters of influence. A free harmonic oscillator is described by the linear homogenous differential equation

$$x''(t) + b \cdot x'(t) + c \cdot x(t) = 0 \quad (b \geq 0, c > 0) \quad (2a)$$

of second order. The solutions $x(t)$ are undamped ($b=0$) or damped ($b>0$) harmonic oscillations. Often the pendulum is also considered as a harmonic oscillator. But the model equation for the angular displacement $x=x(t)$ is

$$x''(t) + b \cdot x(t) + c \cdot \sin x(t) = 0 \quad (b \geq 0, c > 0) \quad (2b)$$

in this case. Hence, this is a nonlinear differential equation of second order. The solutions $x(t)$ are quite different from the previous ones except for small angular displacements x where $\sin x \approx x$.

FRACTIONS

In physics or electrical engineering the simple law of *Ohm* is well-known:

$$R [\Omega] = \frac{U}{I} \left[\frac{\text{V}}{\text{A}} \right]. \quad (3)$$

This law connects three different magnitudes, namely voltage U , current intensity I and current resistance R in an electrical DC circuit. It states that the resistance is directly proportional to the voltage (for constant current intensity) and indirectly proportional to the current intensity (for constant voltage). The law can be checked by experiments. For instance, the equation $U = R \cdot I$ shows that in a circuit with fixed resistance R the measurement points (I_k, U_k) have to lie on a straight line in the I - U plane. Considering small errors in modelling and measurement this is the case at least approximately. A more sophisticated analysis shows that the resistance depends also on the temperature T . So a complex model should describe the influence of T .

In mathematics the sine of angle $\alpha < 90^\circ$ in a rectangular triangle is the ratio of the side (length) a opposite α and the hypotenuse (length) c :

$$\sin \alpha = \frac{a}{c}. \quad (4)$$

This relation is a definition of sine function or at least a consequence of the definition. It can be experimentally checked by comparing the ratio of side lengths in a plotted rectangular triangle and the sine of the corresponding angle calculated by a computer. There will be an approximate equality. But, this is no mathematical proof. It only shows that the model of Euclidian geometry is adequate in the case of plotted triangles. But fractions

$$z = \frac{x}{y} \quad (5)$$

are also used in other fields expressing the fact or the conviction that the magnitude z increases if the magnitude x increases and the magnitude y decreases. The fraction (5) is indeed the simplest model with these consequences. But the same qualitative effects can be obtained by more complex functions $f(x, y, \dots)$ of two or more variables. How to decide which of these functions f is the most realistic one. If there are experimental data of the involved magnitudes, an optimal function f can be found in a defined model class (least squares method).

There are a lot of attempts to use fractions or more general formulas in the humanities. The Russian poet *Anton Chekov* proposed a fraction rule to measure the *value* V of man, where the power (mind, true reputation and other personal properties) determines the nominator and the meaning about himself the denominator of the fraction:

$$V = f(P, S) = \frac{P}{S} \left[\frac{\text{Power}}{\text{Self - Confidence}} \right]. \quad (6)$$

According to this formula the value increases if the power increases (at constant self-confidence) or if the self-confidence decreases (at constant power). Perhaps people believe that these statements are true or at least reasonable. But, P and S are vaguely determined. Besides, other variables should be considered, too. Perhaps it is useless to give a formula for that at all. But, if people can handle mathematical fractions, the formula suggests a social message, namely that modest people with great power are of excellent moral value. By the way, the message depends also on the spirit of the era. Surprisingly such primitive formulas are presented up today. *Marion Wolf*, a German journalist born in 1950, proclaimed: “The greatness of a person is reckoned by his ability in proportion to his modesty”.

BODY MASS INDEX

The book [8] presenting some mathematical topics to a broad audience was the reason to investigate the value of body mass index (BMI). This index was already introduced in 1870 by *Adolphe Quételet*, a Belgian mathematician and statistician. He measured the weight (mass) m and the height l of 5738 Scottish soldiers and found out that the numbers

$$I = \frac{m}{l^2} \left[\frac{\text{kg}}{\text{m}^2} \right] \quad (7)$$

gave a good impression of the soldiers body constitution if the following simple scale was used:

- I is less than 20: *thin*;
- I is between 20 and 25: *normal*;
- I is between 25 and 30: *thick*;
- I is over 30: *fat*.

Although this sample was not at all representative for the whole mankind, the BMI (7) is used with some variations up today. The simple message is that everyone should reach normal weight. Many websites of body care and nutrition industries offer calculators for BMI and advertise products and treatments for getting optimal BMI values. In Germany fat persons have no chance to start a carrier as civil servants. So the BMI is in some sense proclaimed as a measure for health and beauty, respectively. An analysis shows that the index (7) has a questionable value. Since the denominator represents a surface according to the measure, the BMI can be interpreted as average mass load per surface unit of the body. Is the risk of health really increasing

proportional to the mass and indirectly proportional to the squared height (body surface)? Which influence do ages, sex, build or distributions of muscles and fat tissue have? Statistical investigations can help to get a more specific insight. In medicine indeed the scale is modified for woman, children and people with amputated body parts. Another criticism is based on geometrical arguments. Assuming that the body is approximately a cuboid with average density ρ , width $a = \alpha \cdot l$, thickness $b = \beta \cdot l$ and height $h = l$, the BMI is transformed to

$$I = \frac{\rho \cdot a \cdot b \cdot h}{l^2} = \frac{\rho \cdot \alpha \cdot \beta \cdot l^3}{l^2} = \gamma \cdot l \quad (\gamma = \rho \cdot \alpha \cdot \beta). \quad (7a)$$

Hence, the BMI increases proportional with the body height for all people with constant body proportions (α, β constant) and constant density ρ . This is a strange consequence. By the way, supposing more realistic body forms, the consequence is similar. Considering the function

$$z = f(x, y) = \frac{x}{y^2} \quad (x > 0, y > 0) \quad (7b)$$

of two independent variables x, y it has the same structure as BMI in (7). The graph of this function is a surface in the three-dimensional space. Interpreting x as weight and y as height of persons, z is their BMI. Hence, the points (x, y, z) lie on this surface. Since weight and height are dependent in some way, certain surface regions are expected to remain free. Looking for features with constant BMI $z=c$ the corresponding level curves on the surface are parabolas with points $(c \cdot y^2, y, c)$. The BMI values for persons with constant proportions and density lie on a certain curve within the surface having the parameter representation $(\gamma \cdot l^3, l, \gamma \cdot l)$ (see Figure 1).

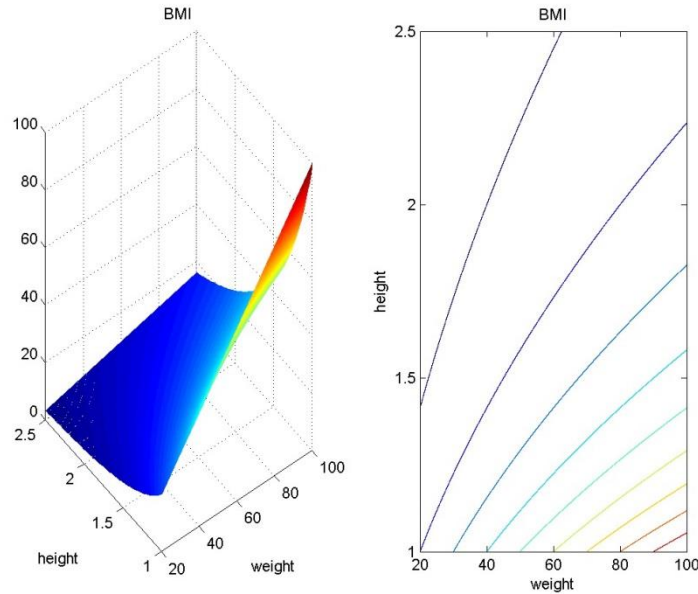

Figure 1: Surface and level curves of function (7b) in the domain $[20, 100] \times [1, 2.5]$.

PROBABILITIES

There are a lot of paradoxes in the field of probabilities, perhaps more than in any other scientific discipline [1], [7]. Some examples containing paradoxes are quite simple to understand, but the common sense struggles against accepting the mathematical results (e.g. Monty Hall paradox, Prisoners' paradox). Who is interested in the mentioned well-known paradoxes should check literature or internet. The crucial point is in both cases to have in mind the effect of conditional probabilities.

The *arithmetic average* is a statistical quantity. It is used to estimate the expectation value of a probability distribution from a random sample. Often people think that average characterizes the typical. So people orientate at average income in their country and compare it between different countries. The country is rich if the average income is high and poor if it is low. But the average income is not at all typical, if only some filthy rich people and a lot of very poor people live in the

country or if middle incomes are very rare. But nowadays the distributions are often not unimodal (as the Gaussian distribution). Figure 2 shows a bimodal distribution. The already mentioned scientist *Quételet* made even a study about *average human* which caused vehement debates. This concept is problematic, among other things, because the averages of single characteristics (as height and weight) do not correspond. Other people even claimed the average is the source of beauty.



Figure 2: Bimodal noisy distribution

It is claimed in the March edition 2009 of the American magazine “Wired” that a mathematical formula caused the Wall Street to collapse and led to the deep finance crisis in the whole world. The well-known Gaussian copula was applied by *David X. Li* to actuarial problems [2]. He used the formula

$$P(T_A < 1, T_B < 1) = \Phi_2(\Phi^{-1}(F_A(1)), \Phi^{-1}(F_B(1)), \gamma) \quad (8)$$

to estimate the risk of finance institutions for investments in correlated securities. The formula gives the probability P that enterprises A and B go bust simultaneously (F_A, F_B distribution functions of T_A, T_B , correspondingly; Φ, Φ_2 one- and two-dimensional standardized Gaussian normal distribution function, correspondingly, γ parameter). The formula can also be extended to more than two enterprises. *Li* used parallels to methods in life insurance in calculating the probability that married couples die in the same year. It was simple to apply this formula, and finance managers used it widely. But the formula contains a parameter, the correlation coefficient γ . *Li* assumed this coefficient to be constant and estimated it on the base of historical data. But at some stage this coefficient

started to increase rapidly, turning into a fast increasing function. The classical model failed under the new conditions. So-called finance experts used Mathematics without understanding the meaning of the underlying actual phenomena. Policy and greed played an important part that the formula (8) was not guilty in this case.

CONCLUSIONS

The essential findings concerning curriculum, competencies and critical thinking in mathematical education of engineering students are:

- It is especially important to know the basics (basic facts as well as basic techniques) because they are used in all mathematical disciplines and in practical applications again and again. Besides, these basics do hardly depend on the historical development. Poor knowledge of basics reduces the chance to get a satisfactory job.
- In some sense it is more important to learn the kind of thinking in mathematics (the methodology) than to learn the solution of certain time dependent problem classes.
- Modelling should be an essential part of the curriculum, since it is necessary to understand the part of mathematics in engineering and in practice. Already simple models show what can happen and why.
- A reasonable curriculum should supply not only problem solving competencies for certain disciplines but also for everyday life to make general processes more transparent. Hence mathematical competencies are important to contribute essentially to the welfare of our society.
- Mathematical educators should encourage young people to act not only emotional to societal developments but also rational using mathematical or logical arguments.

REFERENCES

1. Klymchuk, S., Kachapova, A., Schott, D., Sauerbier, G. and Kachapov, I., Using paradoxes and counterexamples in teaching probability: A parallel study. *Mathematics Teaching Research Journal Online*, 5, 1, 50-70 (2011).
2. Li, D., On Default Correlation: A copula function approach. *Journal of Fixed Income*, Vol.9, Iss.4, 43-54 (2000).
3. Meischner-Metge, A. (Hg.), *Gustav Theodor Fechner – Werk und Wirkung*. Leipziger Universitätsverlag, Leipzig 2010.
4. Quételet, A., Essai de Physique sociale; L’homme moyen. *Physique Sociale*, vol.2, Bruxelles (1869).
5. Schott, D., Mathematical components of engineering competency, *Proc. 10th UICEE Baltic Region Seminar on Engineering Education*, Szczecin (Poland), 47 - 50 (2006).
6. Schott, D., Mathematical curriculum, mathematical competencies and critical thinking. *Proc. 16th SEFI MWG Seminar*, Salamanca (Spain), Electronic Edition, Session 1, 1 - 6 (2012).
7. Székely, G., *Paradoxes in probability theory and in mathematical statistics*. Reidel 1986.
8. Ziegler, G., *Darf ich Zahlen? Geschichten aus der Mathematik*. Piper, München 2011.

ANALYSING UNIVERSITY STUDENTS' ABILITIES IN MAKING ASSUMPTIONS IN A BALLISTICS MODEL: A CASE STUDY

Sergiy Klymchuk

Auckland University of Technology, New Zealand

Zlatko Jovanoski

Abstract

This paper investigates abilities of two groups of university students in making assumptions in a ballistics model. The first group consisted of postgraduate students majoring in applied mathematics from a New Zealand university and the second group consisted of first-year science students majoring in applied mathematics from an Australian university. The students were asked to make reasonable assumptions in a ballistics model from mechanics. We started talking about stones thrown by catapults in ancient times and proceeded to discussing firing balls from cannons in medieval times and launching projectiles and missiles in recent history. Students' responses to the questionnaire on assumptions are presented and analysed in the paper.

Introduction

There are many diagrams produced by researchers and authors of textbooks that illustrate a mathematical modelling process. The diagrams produced by researchers tend to be rather complex like the one presented in table 1.

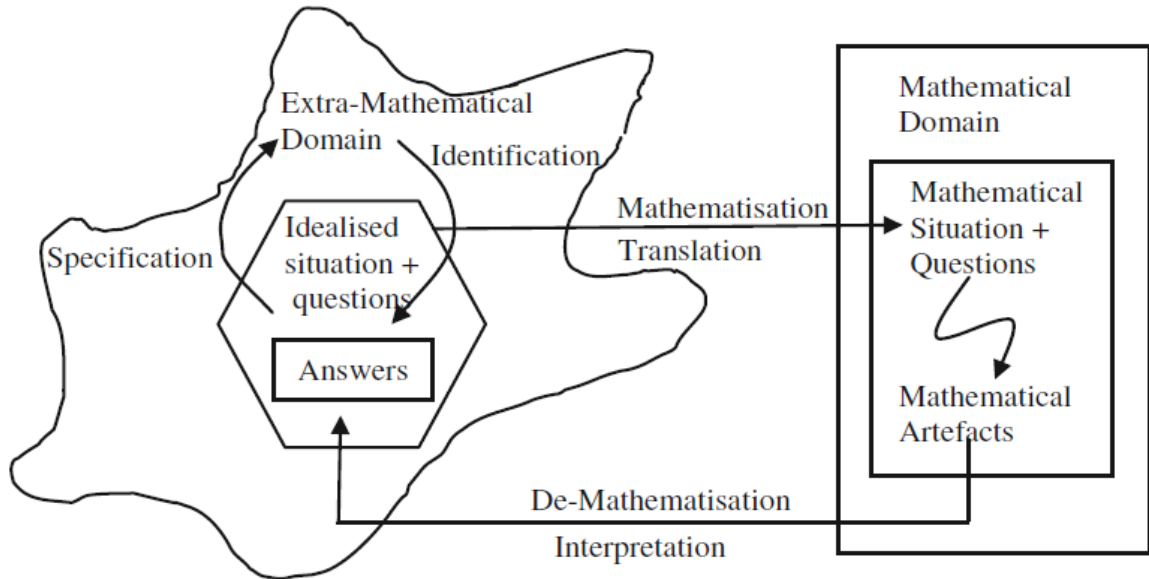

Table 1. Mathematical modelling process by Niss (2010).

Authors of mathematics textbooks tend to produce more practical diagrams that are easier to follow like the one presented in table 2.

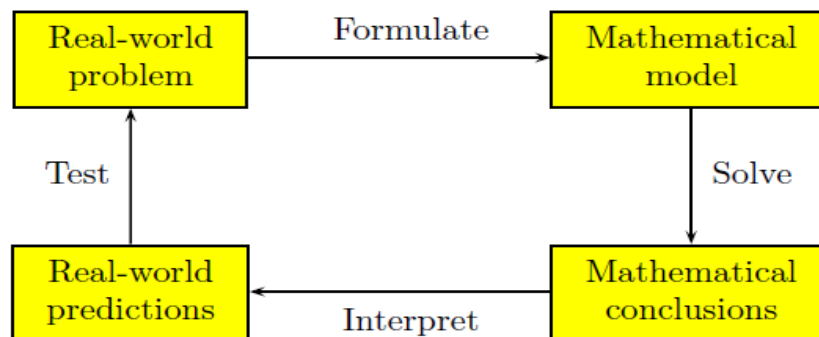

Table 2. Mathematical modelling process by Stewart (2006).

Making assumptions is a paramount and significant part of the formulation (construction/mathematisation) step of a mathematical modelling process. Some diagrams explicitly specify this step like the one presented in table 3.

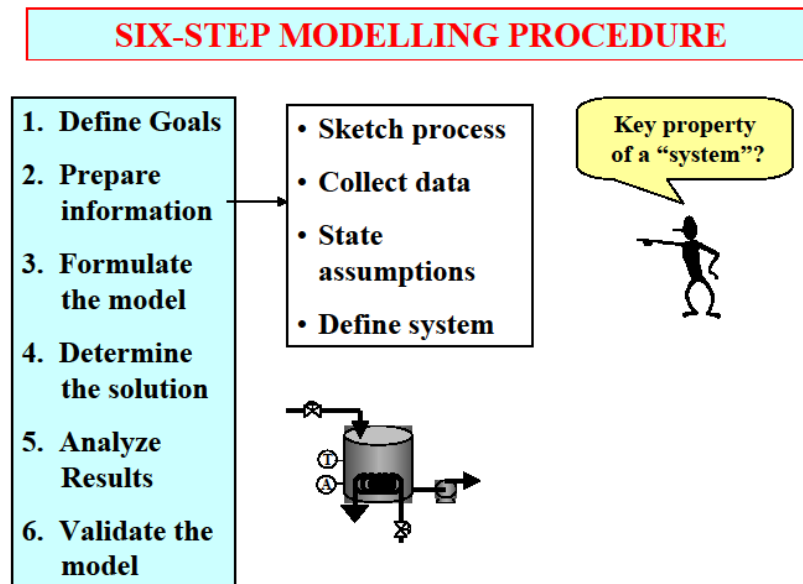

Table 3. Mathematical modelling process by Marlin (1995).

However some researchers express concern that “the role of assumptions in modelling activity has been over-simplified” (Galbraith & Stillman, 2001). Teaching experience shows that often students skip the assumptions stage and rush to “do the sums”. Seino (2005) regards assumptions as the foundation of the proposed model that define the balance between adequacy and complexity of the model: “the setting up of appropriate assumptions can be considered as the most important thing in performing mathematical modelling” (p.664). He proposed ‘the awareness of assumptions’ as a teaching principle to make students understand the importance of setting up assumptions and examine particular assumptions closely. It has a dual role: first, as a bridge to connect the *real world* to the *mathematical world*; second, as promotion of activities that reflect on the formulation step of the mathematical modelling process. Shugan (2007) made more general comments about the importance of assumptions in science: “Virtually all

scholarly research, benefiting from mathematical models or not, begins with both implicit and explicit assumptions...The assumptions are the foundation of proposed models, hypotheses, theories, forecasts, and so on. They dictate which variables to observe, not to observe, and the relationship between them". (p. 450).

Sometimes assumptions are based on modeller's intuition and common sense and not supported by calculations or experiments, especially in the education settings. Grigoras (2011) pointed out:

"The emerging hypotheses in students' work are essentially of different nature than hypotheses in scientific research; like in physics, for example, where stated hypotheses are followed by experiments, and afterwards evaluated, therefore sustained or rejected. Here the students do not check many of these hypotheses, but simply state them and take them as granted. They are either led by intuition or the use of their background knowledge." (p. 1020).

The purpose of the modelling exercise described below was to check university students' intuition and common sense on making assumptions in a ballistics model and to illustrate the importance of making appropriate assumptions.

The Study

A Modelling Exercise

Two groups of university students were given a modelling exercise on assumptions in a ballistics model from mechanics. The first group consisted of 4 postgraduate students majoring in applied mathematics from a New Zealand university and the second group consisted of 61 first-year science students majoring in applied mathematics from an Australian university. The exercise was inspired by the book on applied mathematics (Tichonov & Kostomarov, 1984). We started talking about stones thrown by catapults in ancient times and proceeded to discussing firing balls from cannons in medieval times

and launching projectiles and missiles in recent history. In each of the four cases – a stone, ball, projectile and missile – the distance from the starting point to the landing point was given. In addition, the maximum height for a projectile and missile was also given. The students were challenged to think in each case about the appropriateness of the following four assumptions:

- *The Earth is flat;*
- *The Earth is an inertial system;*
- *Air resistance can be ignored;*
- *Acceleration due to gravity is constant.*

It was agreed that a relative error of less than 3% was not significant. Without doing any calculations the students were asked to indicate which of the above assumptions were reasonable and which were not in each of the four cases: a stone, ball, projectile and missile. They were asked to fill the following table putting “+” in the box if the assumption was reasonable and “-” if not.

OBJECT	Stone from catapult $l = 100 \text{ m}$	Ball from cannon $l = 1 \text{ km}$	Projectile $h = 20 \text{ km}$ $l = 200 \text{ km}$	Missile $h = 200 \text{ km}$ $l = 8000 \text{ km}$
ASSUMPTION				
Earth is flat				
Earth is an inertial system				
Ignore air resistance				
g is constant				

Table 4. Modelling exercise on making assumptions

After completing the modelling exercise the following correct solution was presented and discussed with the students.

OBJECT	<u>Stone from catapult</u> $l = 100 \text{ m}$	<u>Ball from cannon</u> $l = 1 \text{ km}$	<u>Projectile</u> $h = 20 \text{ km}$ $l = 200 \text{ km}$	<u>Missile</u> $h = 200 \text{ km}$ $l = 8000 \text{ km}$
ASSUMPTION				
Earth is flat	+	+	-	-
Earth is an inertial system	+	+	-	-
Ignore air resistance	+(2-3%)	-(15%)	-	+
g is constant	+	+	+	-

Table 5. Solution to the modelling exercise

The suggested correct solution was based on calculations from (Tichonov & Kostomarov, 1984) and consultations with experts. As an example the calculations of the relative errors of the distances in case of a stone and a ball if air resistance is included in the model are presented below:

An object is thrown with the initial velocity v_0 at the angle α to the horizontal.

$$x = t v_0 \cos \alpha; \quad y = t v_0 \sin \alpha - \frac{g t^2}{2}$$

$$y = x \tan \alpha - x^2 \frac{g}{2(v_0)^2 \cos^2 \alpha}$$

$$l = \frac{(v_0)^2}{g} \sin 2\alpha$$

a) Stone from catapult

$$l \approx 100m; \quad v \approx 30m/s$$

Including the air resistance into the model gives:

$$F = \frac{C\pi R^2 \rho v^2}{2}; C - \text{drag coefficient } (\approx 0.15),$$

$$R \approx 0.1m - \text{radius of the stone},$$

$$\rho = 1.3kg/m^3 - \text{density of air}$$

The force due to gravity:

$$P = mg = \frac{4\pi}{3} R^3 \rho_0 g; \quad \rho_0 = 2.3 \times 10^3 kg/m^3 - \text{density of stone}$$

The relative error:

$$\frac{\Delta l}{l} \approx \frac{F}{P} \approx 0.03$$

b) Ball from cannon

$$l \approx 1km, \quad R \approx 0.07m, \quad \rho_0 \approx 7 \times 10^3 kg/m^3, \quad v_0 \approx 100m/s$$

$$\frac{\Delta l}{l} \approx 0.15$$

The Questionnaire

After the discussion of the correct solution the following anonymous questionnaire was given to the students:

Question 1. How many correct assumptions out of 16 did you make?

Question 2. Is common sense and intuition enough to make correct assumptions? Why?

Question 3. Would special knowledge in physics help you to make correct assumptions?

If yes, in which way? If no, why not?

Question 4. Which case (stone, ball, projectile or missile) was easiest to answer for you?

Why?

Question 5. Which case (stone, ball, projectile or missile) was hardest to answer for you?
Why?

Question 6. Which assumption out of 4 was the most difficult to estimate? Why?

Students Responses to the Questionnaire

The participation in the study was voluntary. The response rate in both groups was 100%. Students' comments in both groups were similar so we combined them. Below are summaries of the 65 students' responses and their typical comments.

Question 1. How many correct assumptions out of 16 did you make?

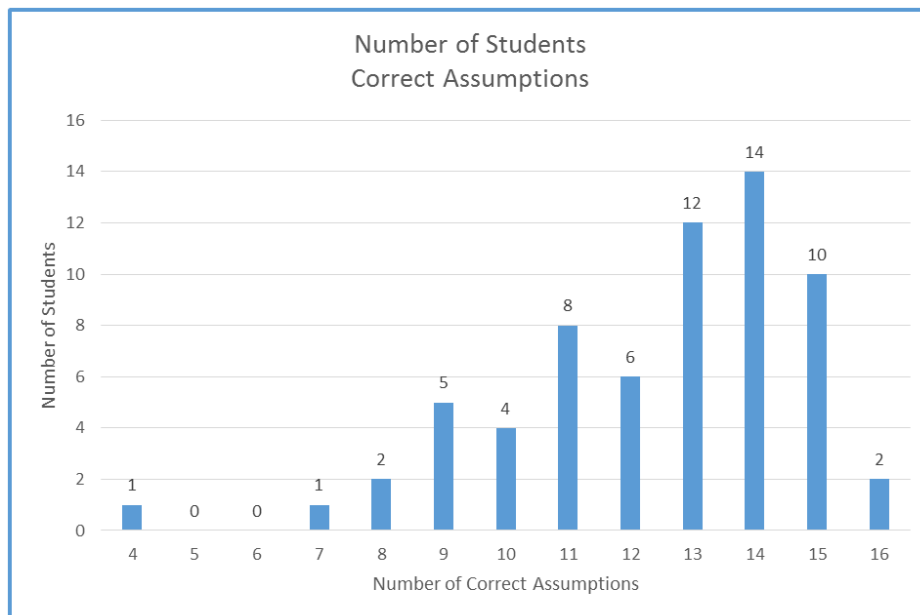

Figure 1. Number of students' correct assumptions

Question 2. Is common sense and intuition enough to make correct assumptions? Why?

Yes – 54%

No – 46%

“Yes, because when you don't quite know the correct answer that applies then common sense will usually provide the most accurate answer”

“Yes, these are simple, practical things we can relate to”

“To a point – but the rules bend in some scenarios and it is these previously learned tricks that are needed”

“No, you can never make assumptions unless it is completely universal knowledge”

Question 3. Would special knowledge in physics help you to make correct assumptions?

If yes, in which way?

If no, why not?

Yes – 86%

No – 14%

“Yes, I used a formula for gravitation in my head to help answer”

“No, physics tends to overcomplicate problems”

Question 4. Which case (stone, ball, projectile or missile) was easiest to answer for you?

Why?

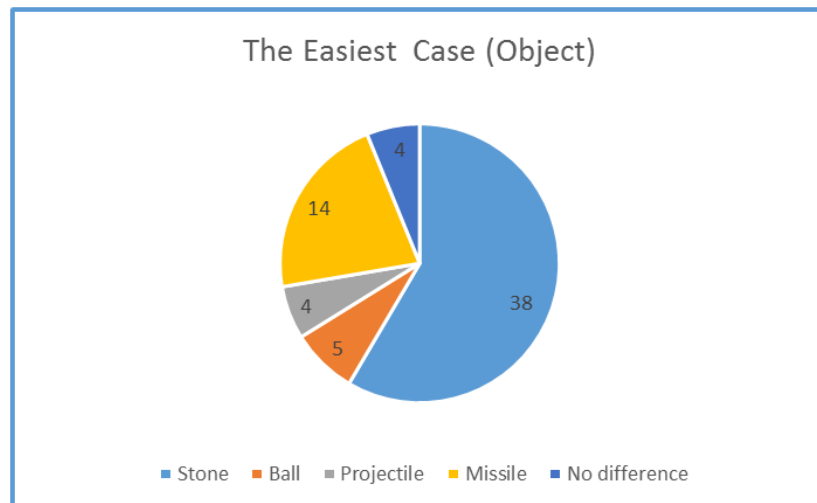

Figure 2. The easiest object out of the four cases.

“Stone, it made sense and was more relevant to my everyday experiences”

“Stone, we have all thrown one once in our life”

Question 5. Which case (stone, ball, projectile or missile) was hardest to answer for you?

Why?

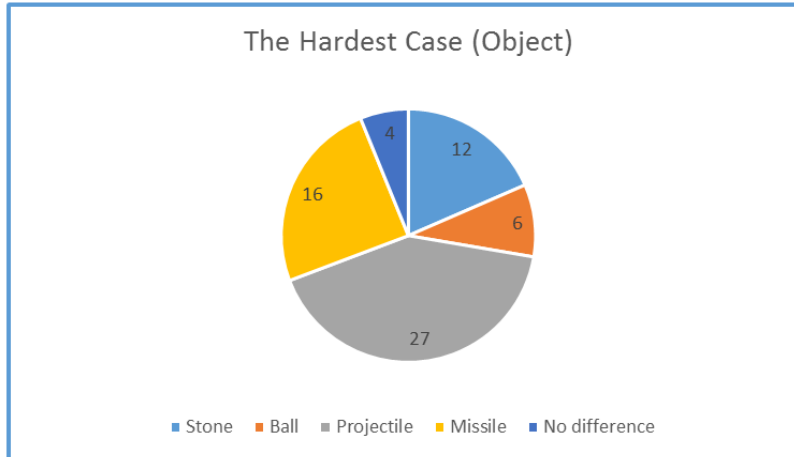

Figure 3. The hardest object out of the four cases.

“Missile, because it needs to consider about projectile force and its movement as it is fired by force that not happen in nature”

“Projectile - too many unknown factors”

“Projectile, it was in the middle range of the other objects”

Question 6. Which assumption out of 4 was the most difficult to estimate? Why?

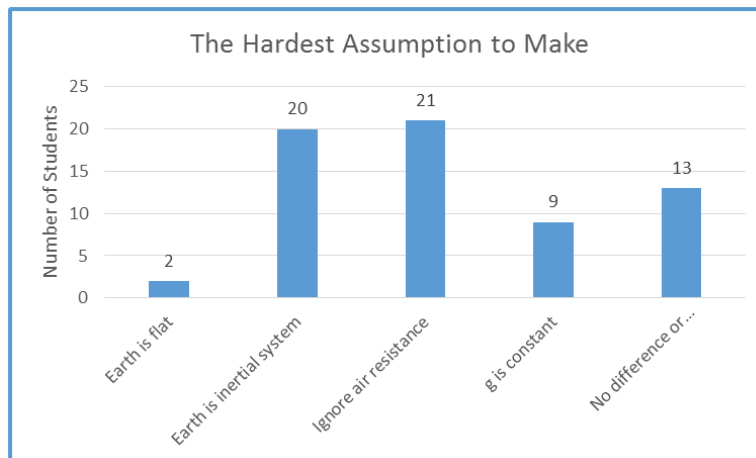

Figure 4. The hardest assumption to make.

“Didn’t know initially what ‘inertial’ meant in this context”

“Ignoring air resistance – it was hard to visualise such scenarios when they do not exist in real life”

Discussion and Conclusions

The distribution of students’ correct assumptions was clearly skewed to the left. Only 2 students out of 65 made all 16 correct assumptions. Another 24 students made 1 or 2 mistakes. So 39 students out of 65 or 60% made 3 or more mistakes. Students’ responses on the role of common sense and intuition in making correct assumptions were polarised – about 50-50. The vast majority of the students (86%) reported that special knowledge in physics helped them to make correct assumptions. Most of the students relied on the practical and familiar experiences in answering the questions about the easiest/hardest object. For most students (63%) the hardest assumptions to estimate across all four objects were “Earth is an inertial system” and “Ignore air resistance” for the reasons related to lack of knowledge (e.g. definition of the inertial system) and everyday experiences (difficult to visualise).

Discussions and observations in class and informal interviews with selected students revealed that the modelling exercise did increase ‘the awareness of assumptions’ (Seino, 2005) and their important role in the mathematical modelling process. In particular, it was consistent with Seino’s claim that it was possible (after the discussion of the correct solution) to develop an awareness of assumptions by making students recognise conditions of the problem as assumptions, by helping students realise how assumptions affect selection of formulas and functions, and whether there are other assumptions to consider. Students found that “what-if” questions were especially helpful in the modelling exercise on making assumptions.

References

Galbraith, P., Stillman, G. (2001). Assumptions and Context: Pursuing their Role in Modelling Activity. In Matos J.F., Blum W., Houston S.K., Carreira S.P. (Eds) *Modelling and Mathematics Education*, Horwood Publishing, 300-310.

Grigoras, R. (2011). Hypothesis and assumptions by modelling – A case study. In M. Pytlak et al (Eds) *Proceedings of the Seventh Congress of the European Society for Research in Mathematics Education*, Rzeszów, Poland, pp. 1020-1029.

Marlin, T.E. (1995). *Process Control*. McGraw-Hill. Slides for Chapter 3: Mathematical Modelling Principles. Retrieved from:
http://www.pc-education.mcmaster.ca/Lecture_Slides/Chap_03_Marlin_2002.pdf

Niss, M. (2010). Modeling a crucial aspect of students' mathematical modelling. In R. Lesh et al (Eds) *Modelling Students' Mathematical Competences*, pp. 43-59. New York: Springer.

Seino, T. (2005). Understanding the role of assumptions in mathematical modelling: analysis of lessons with emphasis on the 'awareness of assumptions'. In P. Clarkson et al. (Eds) *Building Connections: Theory, Research and Practice, Proceedings of the 28th Annual Conference of the Mathematics Education Research Group of Australasia*, Vol. 2, pp. 664–671. Melbourne, Australia: MERGA.

Shugan, S.M. (2007). It's the findings, stupid, not the assumptions. *Marketing Science*, 26(4), 449-459.

Stewart, J. (2006). *Calculus: Concepts & Contexts*. Thomson Brooks/Cole.

Tichonov, A.N. & Kostomarov, D.P. (1984). *Introductory Lectures on Applied Mathematics*. Moscow: Nauka (in Russian).

Teaching and Assessment of Statistics to Employees in the NZ State Sector

Murray Black

Auckland University of Technology, New Zealand
murray.black@aut.ac.nz

Abstract

This paper covers my experiences and reflections both in the teaching and the assessment of statistics to state sector employees. These employees undergo courses in statistics where the taught content and assessments are based on unit standards which have been designed to be relevant with the professional work of the participants. These unit standards form part of the newly-developed National Certificate in Public Sector Services (Official Statistics). This paper uses an action research methodology to ascertain what improvements could be made in the preparation and teaching of the statistical content along with the design and implementation of these unit standard assessment tools.

A review is carried out of the teaching based on the performance criteria of the unit standards, using the first cohort, with the intent of making improvements to materials, teaching approaches and tutorial support for the following cohorts of learners. Also for the learner, support systems recommended include new learning materials, mentoring systems, course organisation changes and tutorials.

An examination is carried out of the questions with respect to their type according to a statistical reasoning level scale and order of presentation within each tool. From the first cohort of students, observations of learner's response times involving dates of requests, submission and re-sits are taken from an extant database. From both a summary of the learner's barriers to completion and an analysis of response times a series of changes for when the tools are to be used again are recommended. These changes involved a redesign of the assessment questions.

Keywords: *Unit Standard, Statistical Reasoning, Performance Criteria*

1 Introduction

The Education Act 1989 established the New Zealand Qualifications Authority (NZQA) to, “oversee the setting of standards for qualifications in secondary schools and in post-school education and training”(NZQA, 1989, section 253(a)).Also it set the legislative base for the National Qualifications Framework (NQF) as one in which “...All qualifications... have a purpose and a relationship to each other that students and the public can understand and there is a flexible system for the gaining of qualifications with recognition of competency already achieved” (NZQA, 1989, section 253(c)). Assessment in the units of learning (unit standards) registered on this framework focused on the measurement of learner performance against published standards called performance criteria (New Zealand Qualifications Authority, 1991 cited in National Qualifications Project Team 2005). Assessment questions are designed to measure achievement with respect to each question being designed to satisfy a particular performance criterion within each unit standard.

In the second half of 2007, a Certificate in Public Sector Services in Official Statistics was introduced as a qualification designed for people working in the State Sector. This qualification provides learners with the range of vocational knowledge and skills required to be able to read, identify and interpret statistics having a state sector context. This certificate consists of 40 credits of unit standards with 24 credits being allocated to those standards which involve applications of statistics. These 24 credits are made up by four core unit standards which are assessed separately. These assessments are based on a series of performance criteria within each unit standard. The unit standards are:

- US 23268: Level 4, 8 credits. Interpret statistical information to form conclusions for projects in a state sector context.
- US 23269: Level 5, 8 credits. Evaluate and use statistical information to make policy recommendations in a state sector context.

- US 23270: Level 4, 4 credits Assess a sample survey and evaluate inferences in a state sector context.
- US 23271: Level 5, 4 credits Resolve ethical and legal issues in the collection and use of data in a state sector context.

A report involving official statistics is selected beforehand and used as an exemplar for the assessments. To obtain credit for each standard, the learner is required to answer all the questions pertaining to the selected report for the assessment correctly. In the case of an answer being incorrect or not fully answered, the learner is offered a re-sit where they review their answer(s) and resubmit (<http://www.statisphere.govt.nz/certificate-of-official-statistics/default.htm>).

1.1 Purpose of Questions

The key objective of the questions is to put the learners in the position of having to read and interpret reports over a range of statistical concepts. In doing so they need to bear in mind the overall objective of the report and how the statistics within the various reports informed the various answers to policy questions. Questions incorporated the following areas;

- assessing the relevance of data
- finding and selecting data relevant to a policy question
- interpreting findings
- making policy recommendations based on the data
- explaining how a particular piece of statistics could be performed with a possible result in the context of the report. For instance, where you would calculate a confidence interval for the difference between means and how the results would be interpreted

- interpreting possible results and designing a data collection to answer a policy or research question and
- explaining the limitations of a chosen exemplar, for instance stating the omission of a margin of error in the report along with possible consequences.

In the case of unit standards 23268 and 23270 a list of topics was developed then questions were written around those topics to ensure full coverage. For unit standards 23269 and 23271 the questions were written around each performance criteria. The assessment questions are a critical aspect of a unit standard as they measure learner performances against a set of learning objectives laid down in the unit standard documents as performance criteria.

1.2 Framework Mappings

A domain of educational activity that can be associated with the requirements of these four assessment tools is the cognitive domain as identified by Bloom (1956). This domain involves knowledge and the development of skills and has six major categories (Bloom 1956). Consequently Bloom's taxonomy was updated and the update published in 2001 by Anderson and Krathwohl. From their update new categories were described as follows:

1. **Remembering:** Retrieving, recognising and recalling relevant knowledge from long term memory.
2. **Understanding:** Constructing meaning from....written.....messages through interpreting, classifying, summarizing, inferring, comparing, and explaining.
3. **Applying:** Carrying out or using a procedure through executing, or implementing.
4. **Analysing:** Breaking material into constituent parts, determining how the parts relate to one another and to an overall structure or purpose through differentiating, organizing, and attributing.

5. **Evaluating:** Making judgments based on criteria and standards through checking and critiquing.
6. **Creating:** Putting elements together to form a coherent of functional whole; reorganizing elements into a new pattern of structure through generating, planning, or producing.

(Anderson & Krathwohl, 2001, pp. 67-68)

We wish to map from the six category levels as defined by (Bloom 1956), denoting degrees of difficulty alongside their corresponding six revised categories as defined by (Anderson & Krathwohl 2001). Then these six categories are mapped alongside, with category levels 5 and 6 combined, to the instructional domains as defined by (DelMas 2002) which pertain to descriptions of tasks and then alongside into five levels of statistical reasoning as proposed by Garfield (2002).

These mappings in hierarchical level order are shown in Table 1 below:

Level	Bloom's Taxonomy Objective	Revised Taxonomy Anderson & Krathwohl	Instructional Domains Teaching	Reasoning Framework Assessment
1	Knowledge Recall	Remembering Recall	Literacy Identify	Idiosyncratic Knows
2	Comprehension Meaning	Understanding Meaning	Literacy Describes	Verbal Defines
3	Application Context	Applying Context	Reasoning Why?	Transitional Partial Understanding
4	Analysis Distinguishes	Analyzing Organizing	Reasoning How?	Procedure Application
5	Synthesis Contextual Links	Evaluating Criquing	Thinking Apply	Integrated Process Complete Understanding

6	Evaluating Construct Report	Creating Reorganizing		
---	--------------------------------	--------------------------	--	--

Table 1
Mapping Links from Taxonomies to Statistical Reasoning Levels

A recent theory of learning which has been widely accepted in education communities stems from earlier work by Jean Piaget, and has been labelled as “constructivism” (Garfield, 1995). This theory describes learning as actively constructing one's own knowledge (Von Glasersfeld, 1987). As the level of statistical reasoning required to solve a problem increases, one has to construct more knowledge and display higher levels of learning, according to the taxonomies in Table 1, of statistical concepts in order to succeed. This makes the required statistical concepts at these higher levels more difficult than others at the lower levels.

The relevance of these five statistical reasoning levels, to the successful completion of an assessment, is such that the correct statistical reasoning required to either read and understand or compose a report should follow all of these levels as steps. Firstly one needs to know the relevant statistical concepts and what they mean. Secondly these concepts would need to be applied to the context of the report and be integrated where relevant to other parts of the report. Finally appropriate conclusions need to be drawn based on these statistical concepts in order to meet the objective of the report. Although not originally designed to be such, ideally the order of questions in a typical assessment of a unit standard should follow these reasoning steps and cover all levels.

2 Aim

This paper considers the following research question: how can the effectiveness of these four unit standard assessment tools be improved in terms of their structure and implementation? To answer the question this paper sets out to evaluate whether the current unit standard assessment tools have been designed appropriately. Also an analysis of the learner responses to these assessments is reported. The objective of this evaluation is to establish a basis for considering changes to the assessment following the findings from the first pilot cohort of learners. As a result of this evaluation by using an action research methodology, this paper describes how both the structure and operation of these unit standard assessments were reviewed and changed where justified by the research for the next cohort of learners.

3 Methods

3.1 Methodology

The research methodology followed here is action research as it's a form of collective self-reflective enquiry undertaken by participants in order to improve the rationality of their own educational practice (Kemmis & McTaggart 1988). The practice being improved here is the design and implementation of these unit standard assessment tools. According to Kemmis and McTaggart (1988) an action research study improves education by changing it and learning from the consequences. Here data pertaining to the first cohort of workplace learners was collected. Then changes were made to the assessment tools in readiness for the second cohort in 2008. The research process consisted of one action research cycle (Kemmis & McTaggart 1988 pp14) After the end of the assessment cycle; the assessments were reviewed with the intent of making improvements. The research design involved two main sources of data:

- an examination of the original assessment questions and

- an analysis of the learner responses to these assessments.

3.2 Examination of Assessment Questions

The data reviewed was already available in Learning State's Assessment Guides for each unit standard. An examination of the 71 questions across the four standards was carried out with respect to the type and order of questions within each standard. A classification of each question into its appropriate statistical reasoning category (refer Table 1) was performed even though the questions were not designed that way.

3.3 Learner Responses to these Assessments

The data reviewed was part of an "extant data base" already available in learning state records and an examination was carried out of the spreadsheet which gave submission, re-sit submission and request dates for each set of assessment questions. Learners requested their assessments on a recorded date then the date of receipt was recorded. The reply date to the learner with any re-sit questions was recorded along with the submission date of their answers. The pass date was also recorded.

The participants in the first cohort give informed consent to the use of their re-sit assessment answers after their passes had been recorded and submitted. A thorough analysis was performed on the re-sits in terms of questions that needed to be re-sat, issues associated with question design, teaching and assessment along with an analysis of timing. The number of successful completions which were 13, 11, 12 and 10 respectively from the four standards, 23268 to 23271 inclusive, were analysed with respect to timing, learner's answers to incorrect questions and barriers to completion for the learners. Also the impact on the level of statistical reasoning required in each question requiring a re-sit was assessed.

4 Results

This section outlines the results that were obtained from an examination of assessment questions and learner responses.

4.1 Type of Questions

Tables 2 and 3 (refer appendix) categorize the answers provided for each question from the assessor's point of view. Data using a scale of 1 to 5 (DelMas 2002) depending on the level of reasoning (Garfield 2002) was recorded. These levels correspond to those in Table 1.

1 = Identify (pick out answer from the report).

2 = Describe with no requirement to answer in context

3 = Why this? – answer requires context to the report in specified part only

4 = How? – some link to more than one part of report is required in context

5 = Apply – all links to relevant parts of report are required in context.

So a reasoning category in the range 3 to 5 inclusive would indicate that the question requires some linkage of the statistical analysis to the context of the report. From tables 2 and 3 we analyse both the order and frequency of the levels of statistical reasoning required to answer the questions in section 4.2.

4.2 Order of Questions

Originally the orders of the assessment questions were designed so the content was tested in the order it appeared in each of the performance criteria pertaining to each unit standard. Table 4 below gives a cross-tabulation between the required level of statistical reasoning to answer the question and each unit standard with the column totals giving the total number of questions within each unit standard assessment tool.

Level	US 68	US 69	US 70	US 71
1	4	2	2	0

2	5	0	9	3
3	6	6	6	9
4	3	5	1	2
5	0	5	1	2
Total:	18	18	19	16

Table 4
of Questions in each Level Category by Unit Standard

Number

Combining the levels 1&2 and levels 4&5 and using percentages so columns total 100% we get Table 5 below:

Levels	US 68	US 69	US 70	US 71
1&2	50%	11%	58%	19%
3	33%	33%	32%	56%
4&5	17%	56%	10%	25%
Total:	100%	100%	100%	100%

Table 5
Percentages of the Questions of each Unit Standard

We note that the two level 4 standards, US 23268 and US 23270 have considerably more questions requiring the lowest two levels of statistical reasoning to answer than US 23269 and US 23271. This confirms what we would expect with the two level 4 standards. Conversely US 23269 have over half its questions requiring statistical reasoning to levels 4&5, at 56%. US 23271 have a lower percentage in the higher level category than expected and 56% in the middle category. This represents contextual links at the lowest level. Ideally these two percentages should be reversed. This could be due to some of its questions revisiting basic concepts as part of scaffolding into questions involving reasoning to a higher level, assuming the validity of Bloom's Taxonomy, throughout the assessment.

If we run a chi-square test using the data tabulated in Table 5 at the 5% level of significance we would conclude that level and unit standard are significantly related ($\chi^2 = 17.7 > 12.592$ at $\alpha = 0.05$ and $\nu = 6$). So irrespective of how the questions were

designed we have significant differences in the proportions of questions containing the various levels of reasoning over these four unit standards.

Figure 1 below displays the levels of reasoning by question order for each unit standard where the line graphs follow the order of questions in the assessment. The continuous nature of these graphs reflects the process over time taken to work through these assessments in question order from low to high.

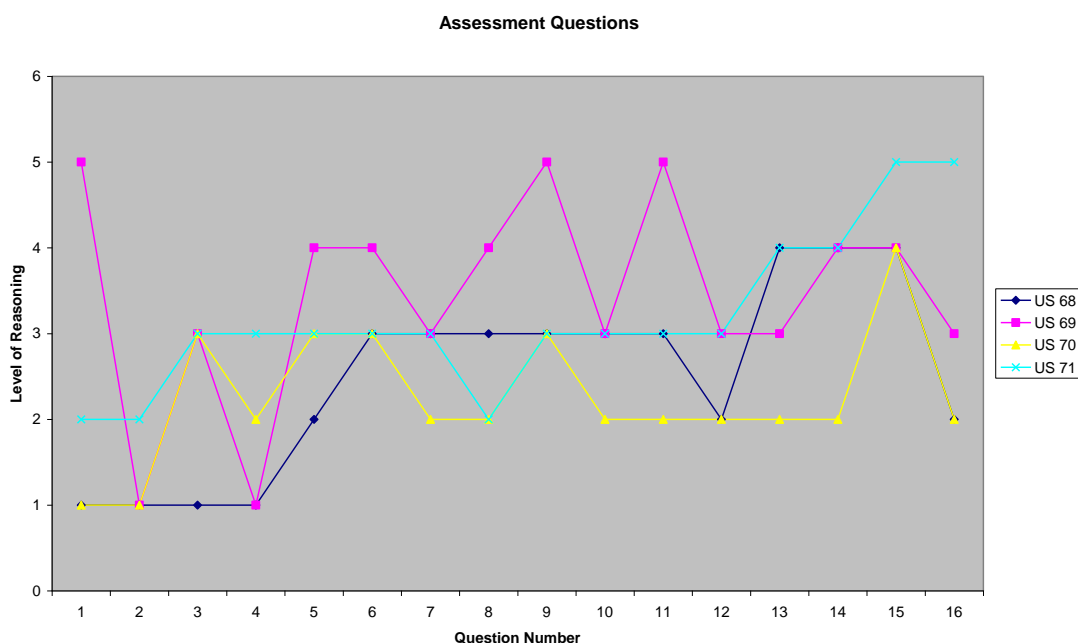

Figure 1
Levels of Statistical Reasoning by Question Order

From Table 1 and Figure 1 we observe that the order of questions for assessing US 23271 follows the levels of statistical reasoning upwards, low to high, with only one drop between questions 7 and 8, by starting off at level 2 and rising to finish at level 5. Also the upward trend in statistical reasoning levels is shown by US 23268 for questions 1 to 15 and in the main by US 23270 except for the last two questions. US 23269 appears to not follow the trend of the other standards and this would be largely due to its questions being designed to sit separately under each of the elements 1 to 4.

4.3 Re-Sit Analysis

In most cases follow up re-sit questions were done by email. Some were done verbally so for these there is no paper trail. There were face to face meetings when the author was down at Statistics New Zealand and also there were phone conversations. Usually any outstanding issues with re-sit questions were cleared up reasonably quickly. On the whole candidates answered most questions correctly first time however there was a high percentage of learners needed a re-sit on at least one question in every unit standard, before passing, as Table 6 shows:

Percentage of Candidates requiring a Re-sit before passing	
US 23268	77%
US 23269	67%
US23270	50%
US23271	60%

Table 6
Re-sit Percentages

Out of those who requested the assessment, Table 7 shows percentages of candidates that passed first time:

Percentage of Candidates who passed first time	
US 23268	23%
US 23269	31%
US23270	50%
US23271	33%

Table 7
First Time Passing Percentages

The common issues involving teaching, assessment design and candidate issues that may have influenced re-sits on at least one question are identified in sections 4.3.1 to 4.3.3 below:

4.3.1 Teaching Issues

There was a lack of teaching coverage of some concepts. Two examples of these noted knew what cyclical variation was in a time series (US 23268) and what performance indicators represented. (US 23268 Q15). In addition, learners had more difficulties with the two quantitative assessments as opposed to the two qualitative assessments.

4.3.2 Assessment Design Issues

Learners were unable to find examples of required content to answer a particular question in the report so it could be answered in context. One area of difficulty was finding an example of a bivariate analysis (US 23268 Q10). There were difficulties in explaining concepts not covered in report. For example, confidence intervals for differences between proportions. This was largely due to assessment requirements where all the concepts in a learner's answer had to be related to a maximum of two reports for each assessment. (US 23270 Q13). Also overall questions in assessment were not being clear enough about what was required to answer the question.

4.3.3 Learner Assessment Issues

In several instances, questions not answered completely. An example of this was stating fully all the 12 privacy principles or only partly answering a question and another

example was a failure to provide appropriate context when required. In other cases the answers were too brief and not enough detail given e.g. recommendations to management. A common occurrence was that only one part of question was answered. For example, the learners were able to distinguish between the two sampling methods, stratification and clustering but were unable to explain why stratification was preferred in the report (US 23270 Q17).

4.3.4 Types of Errors

Overall re-sits occurred because learners were incorrectly explaining statistical concepts in answering questions within the level 4 units whereas re-sits were largely due to incomplete answers to questions in the level 5 units. Part of the reason for this was that the question was not making it clear to candidates what was required for a full answer to the question. All questions and re-sits were handled by email. Specific questions (refer appendix) within each unit standard that required a re-sit are shown in Table 8 below:

Question Number	23268	23269	23270	23271
1	0	2	0	3
2	0	0	0	0
3	1	1	1	0
4	0	0	0	0
5	1	1	1	0
6	2	0	2	0
7	1	1	1	1
8	1	1	4	0
9	0	0	0	0
10	4	4	2	0
11	0	1	2	2
12	1	0	0	0
13	5	2	1	0
14	0	1	1	0
15	3	0	1	0
16	2	2	2	3
17	1	4	4	
18	2	0	0	

19			3	
----	--	--	---	--

Table 8

Frequency of Questions needing to be Re-Sat by Unit Standard

As an overall summary, the nature of the unsatisfactory responses described in three categories of error classification made by the candidates within each unit standard requiring re-sits are shown in Table 9.

Error Classification	US 23268	US 23269	US 23270	US 23271
Incorrect	9	2	7	2
Correct with no context	0	2	8	2
Partially correct with/without context	15	16	10	5

Table 9
Error Frequency

We observe that the major source of error, over all the standards, was that questions were not answered fully enough. Those questions involving at least three learners having to re-sit had the following characteristics shown in table 10.

Unit Standard	Topic	Characteristic
23268	Bi-variate	No practical example
	Time Series Cyclical Variation Irregular Variation	Lack of knowledge Lack of knowledge
23270	Statistical Measures	No proper conclusion
	Weighting of Observations	Lack of knowledge
	Sampling Impacts Stratification	Not attempted

	Clustering	Not attempted
23269	Data Collection Elements	Unclear
23271	Principles of Privacy Act	Not complete
	Data Collection Issues	Recommendations not complete

Table 10
Characteristics of Re-sit Questions

A chi-square test was carried out on the data to see if error classification and level of unit standard were significantly related (Table 11).

Error	Level 4	Level 5
Incorrect	16	4
Partially Correct	33	25

Table 11
Error Frequencies by Level

The question response has been recorded as “not complete” if no context had been provided so the frequencies are sufficiently high enough to validate this test.

We conclude that error classification and error are not significantly related as $\chi^2 = 3.33 < 3.841$ at the 5% level of significance.

4.3.5 Links of Re-sit Questions to Statistical Reasoning Levels

If we tabulate the mean number of re-sit questions per candidate out of the candidates that needed to re-sit and put alongside the number of re-sit questions in each statistical reasoning level, we obtain the results shown in Table 12.

Unit Standard	Mean	Statistical Reasoning Level				
		1	2	3	4	5

23268	2.4	1	7	8	8	0
23269	2.5	0	0	10	3	7
23270	4.2	0	13	7	1	4
23271	1.5	0	3	3	0	3

Table 12
Mean Number and Frequency of Re-sit Questions

We observe in Table 13 that if we rank the mean next to the median of the reasoning levels, taken as a measure of the complexity of a question, from low to high over the four standards we get:

Rank Order	Mean Number of Re-Sit Questions	Median Reasoning Level
1	23271	23270
2	23268	23271
3	23269	23268
4	23270	23269

Table 13
Rank Orders of Unit Standards

The main observation from Table 13 is that US 23270 has the highest mean number of re-sit questions but the lowest median of the statistical reasoning levels when all the others approximately matched differing by only one place. This would suggest that there were difficulties in describing some of the basic concepts having a quantitative nature which were prevalent in US 23270. We wish to examine the pattern of the levels of statistical reasoning required in the 78 questions in total that needed to be re-sat by the learners. This pattern was compared with the overall levels of statistical reasoning required to answer all the questions.

Statistical Reasoning Level	1	2	3	4	5
Total Number of Re-sit Questions	1(1%)	23(29%)	28(36%)	12(15%)	14(18%)
Total Number of					

Questions in Assessment	8(11%)	17(24%)	27(38%)	11(15%)	8(11%)
-------------------------	--------	---------	---------	---------	--------

Table 14
Number of Questions by Statistical Reasoning Level

The main observation in Table 14 is that we have a higher proportion than expected of re-sit questions in the reasoning categories of 2 & 5. This highlights difficulties the learners are having in the areas of explaining statistical concepts and giving their explanations in context to an objective of a report. The reasons for this could be one or more of the following:

1. assessment questions not aligned to statistical reasoning levels
2. not enough time provided for learners to grasp concepts.
3. not enough examples provided in the presentations, and
4. lack of suitable reports for assessment purposes.

A chi-square test was carried out to see if there are there any significant differences in the proportion of questions that needed to be re-sat requiring each statistical reasoning category compared to the overall proportion of questions requiring each statistical reasoning category using the data in Table 13. We get: $\chi^2 = 11.09 > 9.488$ at $\nu = 5-1 = 4$ degrees of freedom at $\alpha = 0.05$.

So we have significant differences in the proportions with higher proportions of the re-sit questions requiring levels 2 & 3 categories of statistical reasoning and lower proportions of re-sit questions being in the levels 1, 4 & 5 categories of statistical reasoning.

Over the re-sit questions a chi-square test was carried out to see if the level of the unit standard assessment tool and the required statistical reasoning level were related.

The four unit standards were collapsed into two categories in Table 15 depending on whether they were at level 4 or level 5. This needed to be done as there were too many

expected frequencies less than 5 as only a maximum of 10% of the cells can have expected frequencies less than five, for the chi-square test to be valid.

Levels		
Statistical Reasoning	4	5
1 & 2	21	3
3	15	13
4& 5	13	13

Table 15
Frequencies of Re-Sit Questions

The outcome of the analysis was $\chi^2 = 9.04 > 5.991$ at $\alpha = 0.05$ so we conclude that level of assessment tool and required statistical reasoning level of questions to be re-sat are significantly related. This was expected as we had established earlier that in the design of the questions, the statistical reasoning level required to answer these questions was significantly related to the level of the unit standard.

4.4 Completion Analysis

There was a group that managed to complete each unit standard in time and keep up. Many asked for extensions from the stated three weeks which was not rigidly enforced. There were however some long periods between re-sits and submissions. Table 16 on the next page provides some summary statistics:

Unit Standard	No Sent Out	No of Re-sits	No of Passes	% Pass Rate	Median Completion Time (days)	Range of Completion Times (days)
23268	13	10	13	100	29	7 to 174
23269	13	8	12	92	37.5	8 to 150
23270	12	6	12	100	20.5	5 to 240
23271	12	6	10	83	24.5	4 to 167

Table 16
Summary Statistics for Completion of Unit Standards

From Table 16 the combined median completion time of 65.5 days was greater for the two level 5 unit standards over the two level 4 unit standards at 49 days, which confirms what we would expect with these unit standards being at a higher level.

Help towards completion was provided by timely feedback on re-sit questions to the point, conversations with learners regarding re-sits topics not understood, for example cyclical variation, index numbers and odds ratios were covered with a session with learners face to face. Feedback was provided to the contact at Stats NZ for tutorials. A summary of the identified key barriers to completion are given in table 17 below.

Completion Barriers	
Design of Assessment	Three weeks completion time
	Too short between presentations
	Fragmentation between the tools
	Absence of clear example
Teacher Dependent	Some concepts not taught fully
	Not enough teaching time
	Difficulties in making up an example
Learner Motivation	Reluctance to request help
	Learners left quantitative assessments till later
	Time management skills
Outside Control	Work commitments of learners
	Effect of instruction diminished over time

Table 17
Barriers to Completion

Overall it was concluded, from table 17 that improving the assessment tools coupled with more learner support with additional teaching would help to overcome these barriers.

Tables 18 and 19 (refer appendix) provide a summary of the days taken to complete each assessment by each learner. From this summary we note the following:

1. The mean re-sit time was substantially higher for the two standards that had the lowest complexity rankings in terms of requirements. In fact for US 23270 and US 23268 approximately one third, 29.9% and 32.8% respectively, of the total learner time spent working on these assessments was working on re-sit questions. Only 2.7% and 2.8% of total time was spent by learners working on re-sits to do with US 23269 and US 23271 respectively.
2. The proportion of re-sits was about the same for each standard with the maximum (0.77) and minimum (0.50) occurring with the two standards 23268 and 23270 respectively of lowest complexity.
3. The % of completions was highest for US 23270 and lowest for US 23269 both in all three categories; one month, two months and three months from delivery.
4. The variability measured by the standard deviation of total times taken for US 23270 is substantially higher at 64.5 days than for the other three standards probably due to the outlier at 240 days.

5 Discussion & Implications

We concluded that the statistical reasoning level and unit standard were significantly related. The level 4 unit standards as expected displayed lower levels of statistical reasoning. Some work needs to be carried out on US 23269 to ensure a more appropriate ordering of questions and minimal work to US 23270. Two key factors causing the need for re-sits were poor knowledge of concepts along with poorly designed questions. Answers requiring re-sits were largely only partially answered. In US 23270 with questions having a statistical reasoning classification of 2 or 5, there were difficulties in explaining statistical concepts and relating them to the overall report objective. The main

barrier to completion was caused by the absence of a report which gave an example of all the statistical concepts being assessed in the standard, Efforts are underway to build on past experiences of using these assessment tools and to review and improve them by making the following changes:

5.1 Assessment Questions

The questions in unit standard assessments; 23269, 23270 and 23271 were modified to give fewer questions and closer alignment with the five stages of statistical reasoning in question sequences. There were now no overlaps in questions requiring similar answers between the four unit standard assessments. This means we can reduce the number of questions and hence “assessment burden” on the learners and still satisfy the performance criteria. The aim was now to have linkages in assessing components of all four standards across one or two common over-arching reports. Other reports were to be provided on a minimal basis to cover assessed statistical concepts not covered by these over-arching reports. Questions were designed so some optional choice was provided in explaining concepts. For instance, explain in context a confidence interval for a mean or a proportion. Learners would need to determine whether the confidence interval being used in the report was for a mean or a proportion then explain their choice in context. The need for learners to switch reports in order to answer all the questions in the assessments was substantially reduced.

5.2 Seminar Presentations

The order of presentation of the unit standards was changed so now the teaching sequence was 23271, 23268, 23270 and 23269 rather than the order 23270, 23268, 23269 and 23271. This was so we can focus the learners more on the overall objectives of a report along with legal and ethical constraints before we teach the various statistical concepts required. Fine tuning of the production of the worked examples as part of the presentation took place. These showed what was required for a pass for different types of questions. New resource material was produced to assist in the presentations of the unit standard material where there was now more emphasis on performance criteria along with their associated statistical concepts.

5.3 Support System

The backup and mentoring systems for learners were extended. There was the provision of pre-courses in relevant material, after a gaps analysis to ascertain entry knowledge of learners, so learners are better prepared. For example, a pre-course on confidence intervals was planned prior to the delivery of US 23270.

5.4 Future Developments

It is possible to have another cycle of action research to assess the effectiveness of these changes to the design and implementation of the assessment tools. Also changes could be recommended to the unit standards themselves with respect to the performance criteria. These could be rewritten to mirror the sequence of statistical reasoning steps that must occur for the successful application of statistical concepts in the workplace.

Reference

Anderson, L.W., & Krathwohl, D.R. (Eds.). (2001). *Taxonomy for learning, teaching and assessing: A revision of Bloom's Taxonomy of educational objectives: Complete edition*, New York: Longman.

Bloom, B.S. (1956), 'Taxonomy of Educational Objectives: The Classification of Educational Goals', *Handbook I; Cognitive Domain*, New York, USA: Longmans, Green and Co.

DelMas, R.C. (2002), 'Statistical Literacy, Reasoning and Learning: A Commentary', *Statistical Education*, Vol 10(3).

Garfield, J. (1995). How Students learn Statistics, *International Statistical Review*. Vol 63(1). pp.25-34.

Garfield, J. (2002), 'The Challenge of Developing Statistical Reasoning', *Journal of Statistics Education*, Vol10 (3).

<http://www.statisphere.govt.nz/certificate-of-official-statistics/default.htm>

Kemmis, S., & McTaggart, R. (Eds.). (1988). *The Action Research Planner* Third edition, Deakin University, Victoria.

National Qualifications Framework project team (2005). *The New Zealand Qualifications Framework, Revised Paper*, New Zealand Qualifications Authority, Wellington.

Von Glasersfeld, E. (1987). Learning as a constructive activity. In *Problem of representation in the teaching and learning of mathematics*. C. Janvier (Ed.). pp. 3-17. Hillsdale, NJ: Lawrence Erlbaum Associates.

Appendix

US 23268	Level of Reasoning Category	US 23269	Level of Reasoning Category
1	1	1	5
2	1	2	1
3	1	3	3
4	1	4	1
5	2	5	4
6	3	6	4
7	3	7	3
8	3	8	4
9	3	9	5
10	3	10	3
11	3	11	5
12	2	12	3
13	4	13	3
14	4	14	4
15	4	15	4
16	2	16	3
17	2	17	5
18	2	18	5

Table 2
Statistical Reasoning Levels

US 23270	Level of Reasoning Category	US 23271	Level of Reasoning Category
1	1	1	2
2	1	2	2
3	3	3	3
4	2	4	3
5	3	5	3
6	3	6	3
7	2	7	3
8	2	8	2
9	3	9	3
10	2	10	3
11	2	11	3
12	2	12	3
13	2	13	4
14	2	14	4
15	4	15	5

16	2	16	5
17	5		
18	3		
19	3		

Table 3
Statistical Reasoning Levels
Level 4 Unit Standards

	US 23270			US 23268		
	Days	Re-sit Days	Total	Days	Re-sit Days	Total
	8	0	8	6	1	7
	143	97	240	4	76	80
	31	30	61	67	3	70
	39	0	39	84	90	174
	10	5	15	10	1	11
	16	4	20	9	1	10
	21	0	21	26	3	29
	22	5	27	70	2	72
	5	6	11	14	1	15
	5	0	5	14	0	14
	15	0	15	66	30	96
	31	0	31	33	0	33
				23	0	23
Mean	28.8	12.3	41.1	32.8	16.0	48.8
Est Standard Dev	37.6	28.0	64.5	28.5	30.9	48.5
Median	18.5	2.0	20.5	23	1	29

Table 18
Summary Statistics of Completion Times

Level 5 Unit Standards

	US 23269			US 23271		
	Days	Re-sit Days	Total	Days	Re-sit Days	Total
	7	1	8	15	1	16
	144	6	150	28	1	29
	130	0	130	32	1	33
	20	1	21	18	1	19
	11	1	12	166	1	167
	40	1	41	10	0	10
	21	0	21	4	0	4

	26	8	34	108	0	108
	133	0	133	20	0	20
	93	0	93	44	8	52
	71	1	72			
Mean	59.4	1.7	61.1	44.5	1.3	45.8
Est Standard Dev	52.4	2.6	52.6	51.9	2.4	52.0
Median	33.0	1.0	37.5	24.0	1.0	24.5

Table 19
Summary Statistics of Completion Times

Unit Standard 70

1. What are the main objective(s) of the survey?
2. List the sources of data used in this survey and if applicable any surveys that this survey provides data for.
3. How would you classify this type of survey? Choose from one-off, time series or longitudinal. Justify both the type chosen and those not chosen.
4. Explain the difference between a sample and the population from which the sample is selected?
5. What sampling procedure has been used and why was that procedure used?
6. How has the sampling been carried out?
7. Explain the difference between sampling and non-sampling errors.
8. How can a set of observations be weighted?
9. Give an example of each of the four different measuring scales where applicable.
10. Explain the difference between the mean and the median.
11. Explain the difference between the standard deviation and the range.
12. What does the margin of error represent?
13. Explain the meaning of the 95% (99%) confidence interval for the mean and a total.

OR

Explain the meaning of the 95% (99%) confidence interval for a proportion.

14. Explain the meaning of the 95% (99%) confidence interval for the difference between two means (or proportions).
15. Explain how non-responses and missing data have been allowed for by imputation and describe the possible impact of this treatment.
16. Explain how a confidence interval can be used to test an inference.
17. Explain the difference between stratification and clustering and describe the impact of these on reporting the results of your survey
18. Explain how confidence intervals can be used to draw overall conclusions.
19. Explain how statistical measures can be used to draw overall conclusions.

Unit Standard 71

Element 1 Identify, describe and assess legal and ethical constraints on the collection and use of data in a state sector context

1. In your own words give a general overview of the twelve principles stated in the Privacy Act.
2. What are the ethics of using an observational study to collect data from people who are not aware that they are being observed?
3. How are respondents to these data collection(s) made aware of the purpose of supplying information and/or of the use that will be made of their data?
4. Give your interpretation of how two of the above Privacy principles apply to the collection and use of data in the public sector.
5. Are respondents [to these data collection(s)] made aware of the measures that will be used to ensure their data is secure? If not, suggest how this could have been done.
6. Explain to someone with less statistics knowledge than yourself two security requirements for public sector data collections.
7. Discuss the adequacy of the privacy and security measures applied to the supplied data collection(s) OR, if these are not described discuss what measures do you consider should be applied.
8. How does confidentiality differ from privacy and what is the overall purpose of confidentialising data?
9. Explain to someone who has less statistics knowledge than you, two methods for confidentialising data.
10. How has the data been protected from accidental disclosure of personal information in the published result(s) OR, if it has not been protected, suggest how this data could be protected?
11. Who can access either the original data set or more detailed result? OR, if this has not been identified, suggest who should be allowed access to each level of data (detailed aggregates, original data set, etc.).
12. In your opinion, is the confidentiality protection applied to this data collection(s) adequate? Write this as a briefing note for your manager to consider.
13. What other ethical considerations have been OR could/ should have been considered with respect to the collection and use of data [in these data collection(s)]?

Element 2 Assess the impact on respondents of legal and ethical issues

14. What measures of response are reported on OR could have been reported on [in these data collection(s)]?
15. Explain to someone with less statistics knowledge than yourself how the quality of the results produced from the data collection(s) supplied could be affected by ethical and legal issues? Discuss at least two potential impacts on respondents.

Element 3 Make and communicate policy recommendations that could help resolve the impact on respondents of privacy, security, confidentiality and ethical issues

16. What changes to the processes related to ethical and legal issues [used in the data collection(s)] could result in reducing the impact of these issues on respondents? Communicate your answer as a recommendation for senior managers to consider.

Unit Standard 68

1. Reference the report(s).
2. What are the main objective(s) of the survey?
3. Name a likely non-sampling error resulting from this survey.
4. Identify all the variables used in this survey
5. Classify all the variables identified as continuous, categorical or neither.
6. What statistical procedure(s) have been used and why is it appropriate in this report(s)?
7. Choose a table of counts (frequency tables) and from that table identify and interpret in context three (row, column and total) percentages and/or proportions.
8. Choose a graph or graphs and at least one other type of numerical summary to draw conclusions appropriate to the context of the survey report(s).
9. Choose a statistical measure(s) and/or distribution from the demographic data to draw conclusions appropriate to the context of the survey report(s).
10. Choose a bi-variate analysis and make three interpretations from plot(s), model and/or correlation measure.
11. Give an example of a performance indicator in the context of the survey report.
12. State what a residual is in linear regression.
13. In the context of the survey report, explain what is meant by cyclical variation in a Time Series?
14. In the context of the survey report what could be conclude from the trend in a Time Series?
15. In the context of the survey report, explain what is meant by the random component in a Time Series?
16. How do we interpret a seasonally adjusted time series?
17. Calculate and explain an odds ratio.
18. Calculate and explain an index number.

Unit Standard 69

Element 1: Assess data collections relevant to a policy questions

1. How well do the objectives of the data collection fit the policy question(s)?
2. What is the population that data is required for?
3. If a sampling procedure has been used, describe its main features.
4. What information is being collected?
5. What topics (objectives) do the questions relate to?
6. What aspects of the data collection or analysis affect its use?
7. What is one main result from this study (answer in the form of a possible headline for an article)?

Element 2 Identify and select relevant data collections to make policy recommendations

8. What data collections have you identified that could be used to answer this question?
9. How can these data collections be used to answer the policy question?

Element 3 Describe a statistical information collection that can be used to answer a specific policy question

10. Give the key elements of a data collection that could be used to answer the given policy question?
11. Describe one possible main result (as EITHER a potential press release OR a newspaper article).
12. Describe what sort of graph(s) you could include in your article (in question 11).

Element 4 Evaluate reports based on statistical information to make policy recommendations

13. What constraints are there on the stated conclusions in the supplied article(s) or report(s)?
14. Do the supplied report(s) or analyses use data that is appropriate to answer the policy question given in element 2? Write your answer so that it could be understood by someone with less statistics knowledge than you.

Element 5 Use reports based on statistical information to make policy recommendations

15. What results or statements made in the supplied report(s) are relevant to the policy question given in element 2?
16. How does the supplied data collection(s) differ from the one you proposed in question 10?
17. How could the data collection(s) have been used to answer this question? OR, How could the data collection be changed so that it could be used to answer this question?
18. Use the result(s) of the analyses described in question 17 to make a policy recommendation or recommendations for your manager to consider.

Throwback Thursday, Academia Edition

Dr. Kathleen M. Doyle

Hostos Community College
City University of New York

One of the more popular trends on social media sites is the concept of Throwback Thursday, #TBT for short. The concept is very simple: Take an old photo or journal entry and reflect on it now. Given the nature of most social media, these tend to be very short commentaries such as, “I can’t believe I had green hair in 1986!” or “Wow, I had great taste then! Classics shouldn’t change.”

Recent events in my academic career have made me realize that as academics, we don’t exactly throw things out. We tend to keep things in our offices, in our files, our bookshelves, hoarded away in manila envelopes.

Why not bring those items out for #TBT? Let’s dust them off and see how far we’ve come or how much we’ve stayed the same.

For my first throwback, I picked a short paper that I wrote while in graduate school. In the fall 2000, I was enrolled in the course “Mathematics Teaching and Learning” with Professor Bruce R. Vogeli. Professor Vogeli would grade these critiques while lying on his couch at the end of his teaching day. So his comments are not always legible because he was writing them upside down! The assignments were very simple. We were to pick a journal article related to that week’s lesson and critique it. I’ve pulled the paper out of my file and scanned it, exactly as is.

The comments are a little hard to read because they are:

Comment 1: “One of my teachers—the world’s best mathematics lecturer! He was a visiting prof at Michigan!” Michigan is where Prof. Vogeli went to graduate school.

Comment 2: “But when Halmos speaks, many listen!”



MATHEMATICS TEACHING-RESEARCH JOURNAL ONLINE
VOL 8, N 1-2
Fall and Winter 2015/16

Comment 3: “Of course impractical”. My three hole punch cut off part of the word.

Comment 4: Yes, it’s a smiley face!

Comment 5: Try it and see!



ONE OF MY TEACHERS -- THE WORLD'S
BEST MATHEMATICS LECTURER! HE
WAS A VISITING PROF AT MIT (LEARN)

Kathy M. Doyle
Mathematics Teaching and Learning
Halmos, P. (1980). The heart of mathematics.

Prof. Vogeli
November 1st, 2000

American Mathematical Monthly, 87, 519-524.

Halmos asserts that the heart of mathematics is problem solving. He believes that problem solving is unfortunately neglected in mathematics courses and that problems are viewed as second rate to theorems and proofs. Given that I have spent the past five years as a graduate student in applied mathematics, I agree that problem solving is an integral part of both the mathematics curriculum and "a meaningful life" (p523). But this article only presents anecdotal evidence that problem solving improves students mathematical ability. This article is essentially a book review of some classic problem books. The problems were quite tempting and I admit I spent a bit of time working out how many zeros are at the end of $1000!$ (211) and examining the "curiosity" : for each positive integer n , which is bigger $\sqrt[n]{n+1}^n$ or $\sqrt[n]{n}^{n+1}$?

BUT WHEN HALMOS
SPEAKS, MANY
LISTEN!

I disagree with Halmos' solution to the problem of incorporating more problem solving into the mathematics curriculum. He believes that students should discover material and his solution to the "time, time, time" problem is to cover less material. This might be perfectly acceptable in a graduate course in mathematics but I find it hard to imagine an elementary school teacher giving a "ten-minute mention" of subtraction so that her students have time to discover addition on their own. Even undergraduate courses have a certain required syllabus.

OF
COURSE
I
DARE
TO
IMAGINE

Mathematics curriculum is not that flexible and at most levels is frequently not up to the instructor to decide which topics to cover. He also suggests problem seminars as a method to expose students to mathematical problem solving. In my experience, such seminars already exist in the form of math clubs and graduate seminars.

I propose a different solution. In Stodlosky's article on math anxiety, she mentions a study that found that 32% of 17 year olds dislike math and 25% dislike English. Let's examine the requirements in the second most hated subject. In high school, four years of English are required. As an undergraduate in most colleges one is required to take three semesters of English, usually two in composition and one in literature. I don't think any English teachers lost sleep over assigning homework over the summer in the form of reading lists. Why do mathematicians not require more of their students time? Do we have such a collective guilt complex because we are the most hated subject? I really don't think this is a reason to excuse or omit material. If our major constraint in teaching well is "time time time" why do we not demand more time? I am not suggesting that time alone will improve mathematics teaching but it does give a teacher the option to implement different teaching methods without having to compromise content.



TRY IT AND SEE!

Fifteen years later, I stand by this conclusion! I think we should demand parity with other disciplines. I firmly believe we deserve the same resources and time that other disciplines receive. No one thinks twice about saying, “Oh, ha-ha, I can’t even balance my checkbook!” But no one would ever brag that they can’t read a newspaper headline! This view of Mathematics as being less worth the time and effort it takes to learn it must change. It hasn’t changed in the time since I wrote the original article. It is still acceptable to push Mathematics out of the way for other subjects for various reasons.

Halmos’ article was about graduate level mathematics education and he is describing a scenario where the instructor is free to pick the course topics as though there is no course afterwards. His view is from a very tall ivory tower and is not necessarily practical advice for someone who teaches undergraduates, especially when considering developmental undergraduate work. His solution to implement discovery learning is to have a course based in problem solving where students are asked to solve 20 problems and discover the solutions themselves. The instructor should talk for 10 minutes and then let the students work on discovering the answer to the problems. The problems in his article are meant for upper undergraduate students to graduate students. It is generally accepted that this is a great technique because students remember things they have discovered rather than material an instructor has presented. The classic reasons why small group instruction or discovery techniques aren’t used are the following three reasons: Time, time and time. It takes a lot of time for students to discover solutions on their own. Further, their improvised methods don’t always generalize to later classes;

they need to know common terms and solution methods. There are courses that stand alone where it's possible to use discovery learning but they are rare and not the norm for undergraduate Mathematics courses. Halmos' view was so impractical which is why I criticized him so harshly. He proposed to solve the issue of not having enough time to teach by teaching fewer topics. Clearly that's not possible in most Mathematics courses as they are so sequential. Why not demand more time?

In some cases we've been able to accomplish demanding more time. For example, we have a supplemental instruction program at Hostos Community College where some of our courses meet four or five days a week in order to help our developmental students succeed with their Mathematics courses. Students meet three days with the course instructor and then they have one or two days with a peer leader who is a specially trained tutor who works with faculty to ensure their sessions enhance what the instructor is covering in class. Contrary to Professor Vogeli's remark, we were able to get more time for our classes! It's such a huge issue because asking for more time means that you are asking the school for more money. That's why he commented that it would be so unlikely that we would ever get more time.

Unfortunately the extra time is mostly spent on reinforcing basic skills because the curriculum is so packed that instructors must lecture. Unlike Halmos' ideal world where students solve only 20 problems and discover the answers on their own, we're preparing students in basic arithmetic and algebra. They have to be able to move on to college level work afterwards. The curriculum of our two developmental courses is not

even developed by the faculty. It is handed down from the central university office so that it is the same across all colleges in the university and it is a very full syllabus. However with the extra time, the instructor can cover a topic quickly and know that the students will have extra time to review examples with their peer leader. So having the extra time relieves some of the pressure on instructors but not all of it.

Discovery learning is also not necessarily appropriate for adult learners. Adult learners are not discovering topics for the first time as K-8 students are. Adults are re-learning basic skills in our developmental courses. They know what multiplication is, for example, they know that multiplication is repeated addition. But our students can't recall their multiplication tables fast enough. They understand that division is separating a total into equal groups but when you go through the division algorithm with them, they cannot recall their times tables fast enough to do the estimation necessary for long division. So when we have extra time, we spend that extra time doing drills and additional problems, not discovery learning.

It's very counter-intuitive and rather politically incorrect to say that you would rather drill your students on their times tables, but that's what they need. In some way, our students have actually been harmed because they remember concepts and not facts. They were never asked to sit down and memorize or they were allowed to use calculators. The addition of extra classroom time in our developmental courses does provide a ray of hope that it might be possible for Mathematics to gain more control over our curriculum and more time to cover material in a way that is appropriate for our students. Adult

learners need a different kind of support than K-8 students and having more classroom time affords the instructor more choices to choose what is best for her students.

I also recognize that I was right that mathematics doesn't get the same treatment as reading and writing. For example, we had two initiatives at my college: "Writing Across the Curriculum" and "Mathematics Across the Curriculum." The idea of both projects is to incorporate material into more courses. For example, put more Mathematics into a Psychology course. Or put more writing into a science course. Guess which initiative is still going and guess which one has fallen by the wayside? This is the sort of basic parity we deserve in the field of Mathematics.

Over time, my opinion hasn't really changed much. I'm fortunate to work with colleagues who are equally passionate about education, who are willing to put in many hours documenting the success of our supplemental instruction program and about changing perceptions of Mathematics across our culture.