

Standards Bulletin VSB 12 Rear Marking Plates

*For all motor vehicles over 12 tonnes GVM
and for all trailers over 10 tonnes GTM*



General Requirements

All vehicles with a gross vehicle mass (GVM) over 12 tonnes and trailers with a gross trailer mass (GTM) over 10 tonnes must be fitted with retroreflective rear marking plates. Buses with a gross vehicle mass over 12 tonnes must also be fitted with rear marking plates but buses fitted with hand grips or similar equipment for standing passengers to hold are exempt from these requirements.

Prime mover and semi-trailer combinations must display the plates at the rear of the semi-trailer.

Rear marking plates may also be fitted to any motor vehicle with less than 12 tonnes gross vehicle mass or to any trailer with less than 10 tonnes gross trailer mass. If your vehicle (meaning the towing vehicle together with the trailer and projecting load) is 7.5 metres long or longer, you may then also have the sign *“DO NOT OVERTAKE TURNING VEHICLE”* displayed at the rear.

Rear marking plates may also be fitted to light vehicles. However, in certain jurisdictions if the vehicle is less than 7.5 metres long, the plates must **not** have the words *“DO NOT OVERTAKE TURNING VEHICLE”*.

Australian Standards AS 4001 – 2003 Motor Vehicles – Rear Marker Plates Parts 1 and 3 (Manufacturing requirements) and Part 2 (Fitting requirements) provides for plates made from Class 1, Class 1A and Class 2 retroreflective material. Class 1 retroreflective material is more durable and because of its improved retroreflective performance, when compared to the older Class 2 plates, the plates can be smaller and yet reflect more light. Class 1A pressure sensitive plates have been developed so that these plates can be affixed directly to the vehicle without a metal backing plate.

You may use either style provided that both plates on any one vehicle are of the same size and material. Plates complying with AS 4001 are available in either rectangular or strip configuration as illustrated in the Figures 1 and 2 respectively.

Class 1 plates are preferred because they outperform and outlast Class 2 plates.

Types of Class 1 retroreflective material marking plates

Dimensions and graphics of the Class 1 rear marking plates are shown in the following diagrams. Class 1 rear marking plates are referred to by a code based on the overall width and height of the plate (eg. 31 for a 300mm wide x 100mm high plate). Where applicable, this number is followed by a letter, L to indicate a legend only plate (eg. *“DO NOT OVERTAKE TURNING VEHICLE”*) or a letter A, B or C to indicate the inclination of the colour bands on a “strip” plate.

The size of approved Class 1 rear marking plates are listed in Table 1.

When installed on a vehicle, rear marker plates shall be at a height above the road surface and at a distance in from the outer edge of the vehicle, as specified in Table 2.

TABLE 1 OVERALL SIZE OF PLATE

Category	Dimensions width x height (mm)
31 L	300 x 100
33, 33 L	300 x 300
34A, 34B	300 x 400
161	1,600 x 100
81	800 x 100
41	400 x 100
615	600 x 150

TABLE 2 INSTALLATION SPECIFICATIONS

Category	Position description	Dimensions (mm)
33 33 L 34A, 34B 31 L	Side of vehicle to outer edge of mounted plate (see Note 1)	500 max.
81A 81C 41A 41B	Height from road surface to underside edge of mounted plate (see Note 2)	400 min. 2000 max.
161 81B	Side of vehicle to outer edge of mounted plate (see Note 1)	On vehicle centreline
	Height from road surface to underside edge of mounted plate (see Note 2)	400 min. 2000 max.
615A 615B	Side of vehicle to outer edge of mounted plate (see Note 1)	200 max.
	Height from road surface to underside edge of mounted plate (see Note 2)	300 min.

NOTES FOR TABLE 2:

1. ‘Side of vehicle’ corresponds with the maximum-width-of-vehicle plane, excluding rear vision mirrors, side lights, and other projections.
2. Height of plate to be determined when the vehicle is unladen and parked on a flat horizontal surface.

Note: Australian Standard AS4001.2-2003 “Motor vehicles – Rear marker plates Part 2”, contains additional information about fitting requirements of Class 1, Class 1A and Class 2 marking plates.

Figure 1 – Rectangular Class 1 and Class 1A rear marking plates

(all dimensions in millimetres)

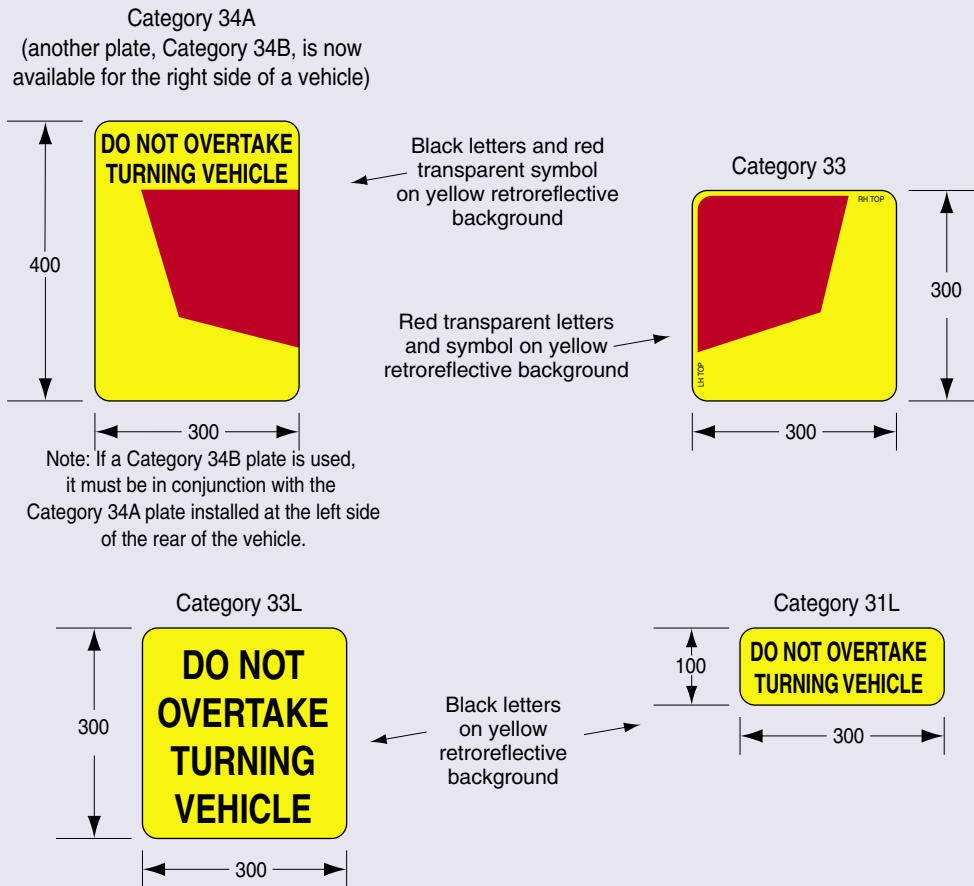
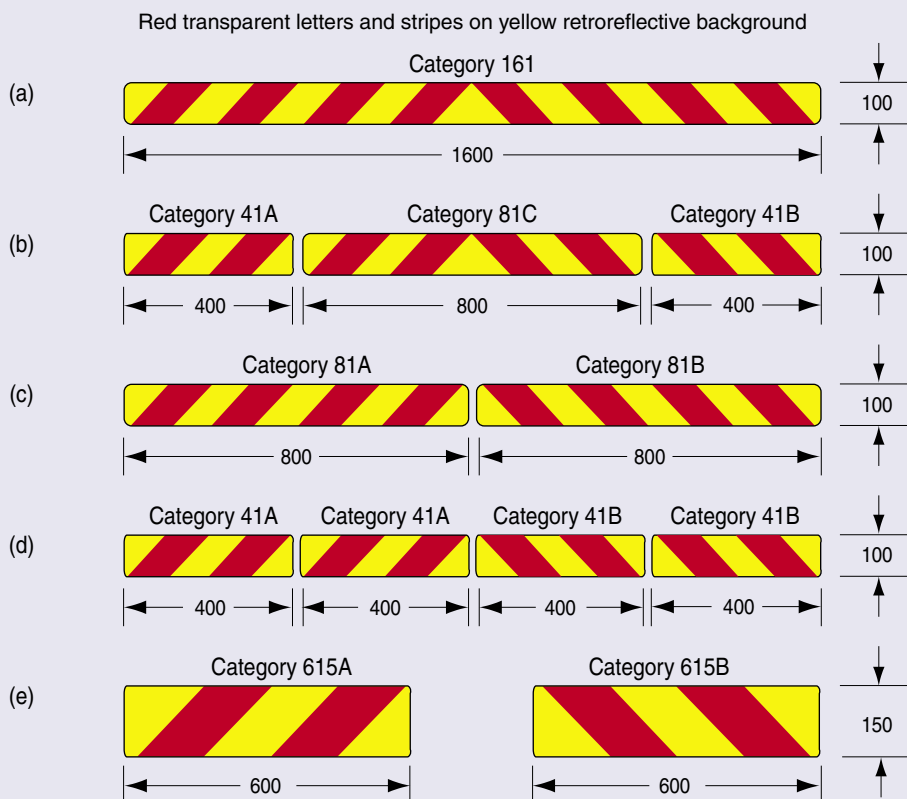

Figure 2 – Class 1 strip type rear marking plates

(all dimensions in millimetres)



Note: Category 615 plates are intended only for horizontal installation on the rear of prime movers.

Types of Class 2 retroreflective material marking plates

Figure 3 – Preferred style plates

(all dimensions in millimetres)

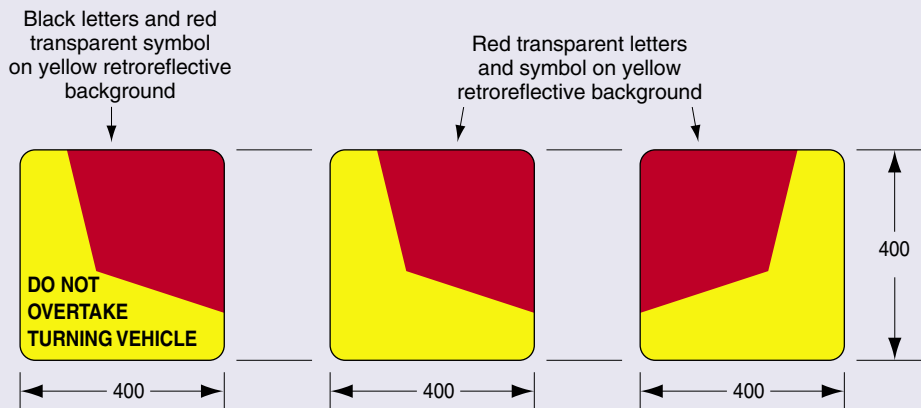
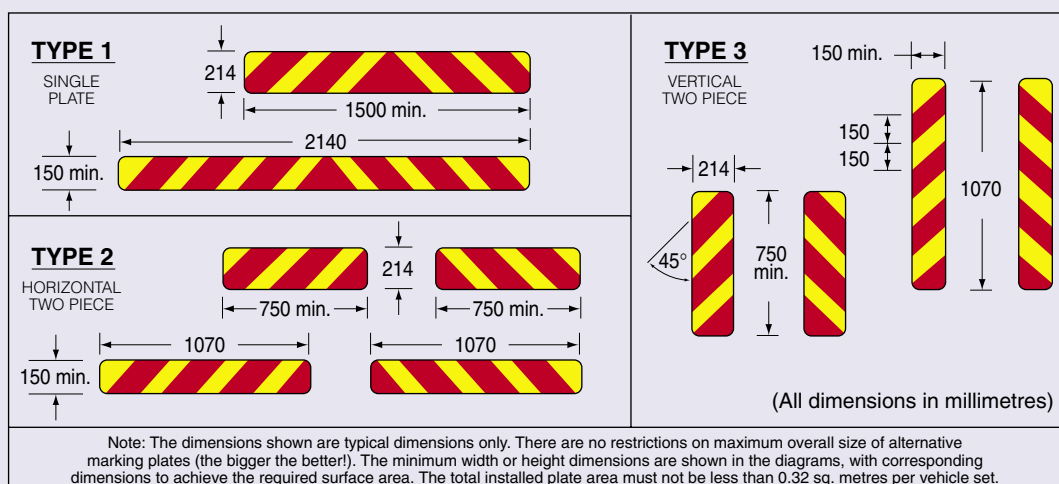

Figure 4 – Alternative styles of class 2 plates

(for use where it is not possible to fit preferred plates)



Apart from the dimensions and design, alternative style marking plates must meet all of the requirements for the preferred square plates, including the use of approved retroreflective material and words.

Use of an alternative style plate is not permitted unless the standard plate (see Figure 3) cannot be fitted.



Difficult installations

On vehicles with skeleton structures, such as carriers or trailers, plates can be attached to fabricated supports well clear of the load or to moveable panels which can be swung aside for loading (similar systems are used on vehicles such as boat trailers to mount registration plates and rear lamps). Car carriers with tip-up loading ramps can have the marking plates attached to the underside of the ramps.

Where it is necessary to mount plates across the edges of moveable or opening panels, the plates may be cut in two and attached to adjacent panels, provided the gaps between the portions are not wider than 10mm. It will be acceptable, when cutting plates to remove a strip of material (not wider than 10mm) along the line of the cut, so that the overall dimensions of the plates can be maintained. Alternatively, the sections can be moved apart.

Markings

The front reflective surface of the plate must bear the name of the manufacturer or agent. In addition, Class 2 marking plates must also be marked with the words “AS1906 Class 2” or “AS4001.2 Class 2”. “Class 1” plates also display letters indicating the correct orientation on the vehicle.

When buying plates, make sure that this information is provided on each of them. Plates without this identification will not be accepted.

NOTE: Rear marking plates do not qualify as reflectors.

Installation requirements - Class 1, Class 1A and Class 2 marking plates

- A vehicle must not be fitted with a mixture of Class 1 and Class 2 retroreflective marking plates.
- Rear marking plates are to be located on a rear, near-vertical surface.
- Pairs of marking plates should be positioned symmetrically about the centreline of the vehicle and at the same height from the ground.
- It is recommended that for vehicles over 7.5 metres long, the “DO NOT OVERTAKE TURNING VEHICLE” sign be fitted, either as a separate sign located on the left hand side or incorporated in the left hand side marking plate. If such a vehicle (meaning the towing vehicle together with the trailer and load) will need to straddle lanes when turning, then it **must** be fitted.
- It is not permitted to fit categories of rear marker plates containing the text “DO NOT OVERTAKE TURNING VEHICLE” (i.e. ‘Legend’ plates 34, 31L and 33L) to vehicles with an overall length less than 7.5m, other than to the trailer or semitrailer of an articulated combination, where the total articulated vehicle length will exceed 7.5m when coupled.
- The colour bands of all “strip” type rear marking plates shall be oriented to slope down and outwards (away from the centre of the vehicle).
- Rear marking plates should not be bent to suit the contour of a non-flat mounting surface.
- Cutting of the marking plate to suit a restricted space or to span fixed and moveable sections of the vehicle should be avoided and alternative styles of marking plates should be considered. Where cutting is unavoidable, any resulting gap between the sections of the plate should not exceed 10mm after installation.
- Category 615A and 615B Class 1 material rear marking plates are intended only for horizontal installation on the rear of a prime mover. (See figure 10)
- Class 1 retroreflective material must be applied to the required backing material made of aluminium and complying with AS1734. Application directly to the vehicle is also permitted. Class 1A plates have been developed for these situations and are permitted in the 2003 Australian Standard.
- Australian Standard AS4001.2 – 2003 contains additional information about the installation of retroreflective rear marking plates.

Installation of rear marking plates made from Class 1 and Class 1A material

Figure 5 (Class 1)

(all dimensions in millimetres)

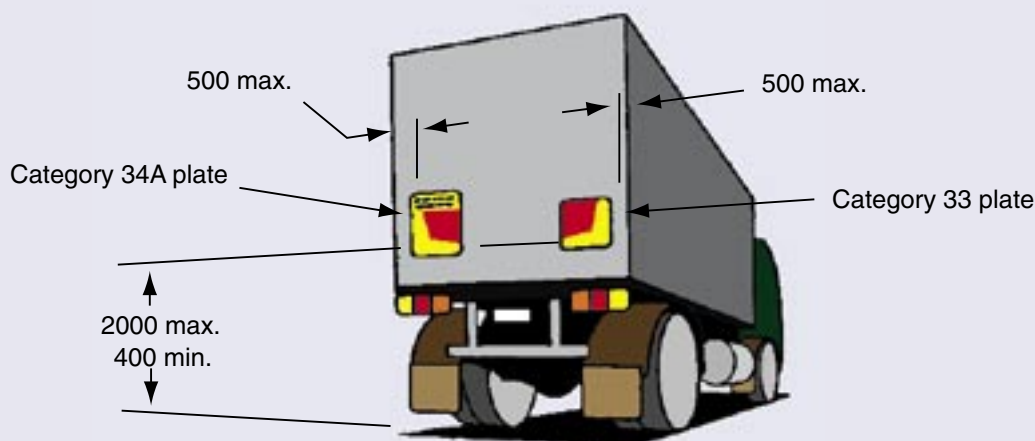

Figure 6 (Class 1)

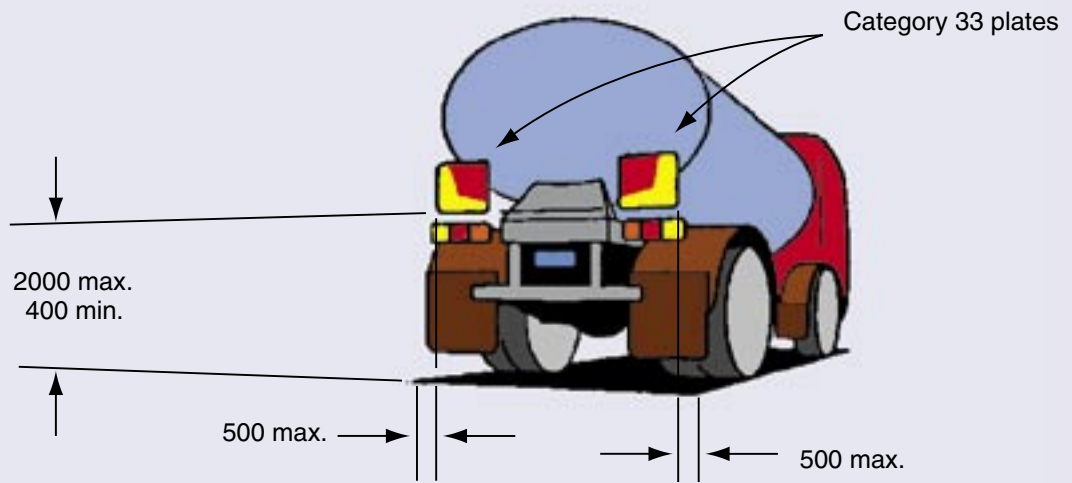

Figure 7 (Class 1)

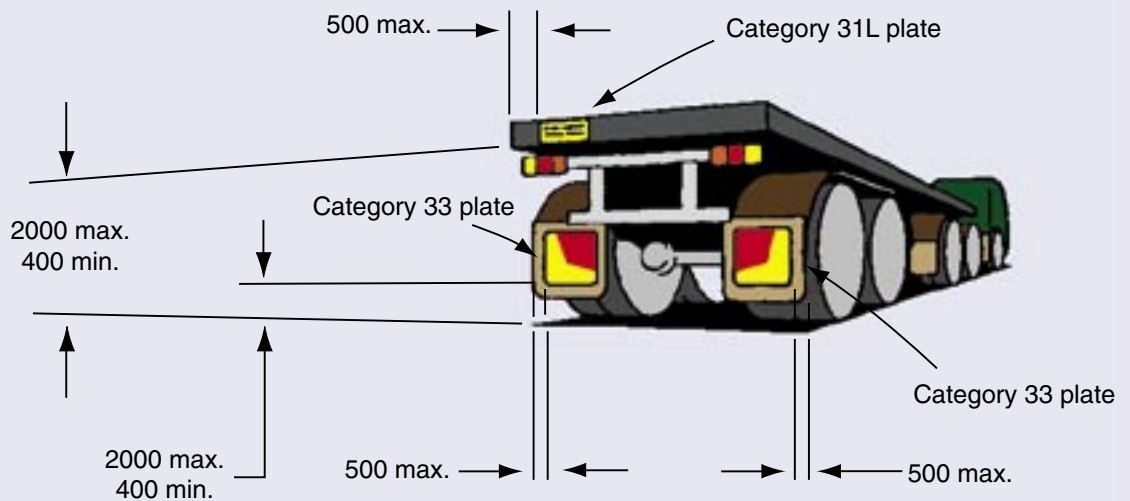

Figure 8 (Class 1)

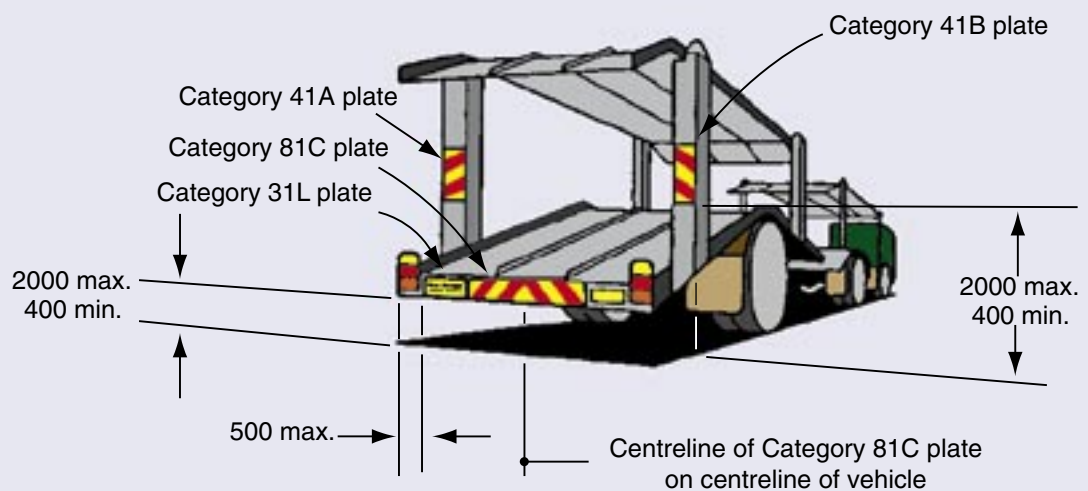

Figure 9 (Class 1)

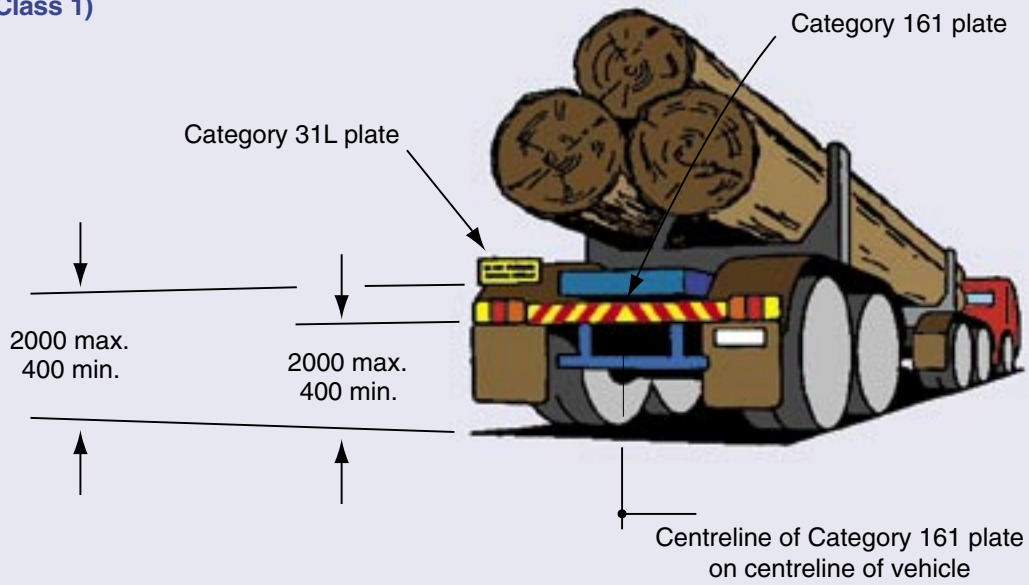
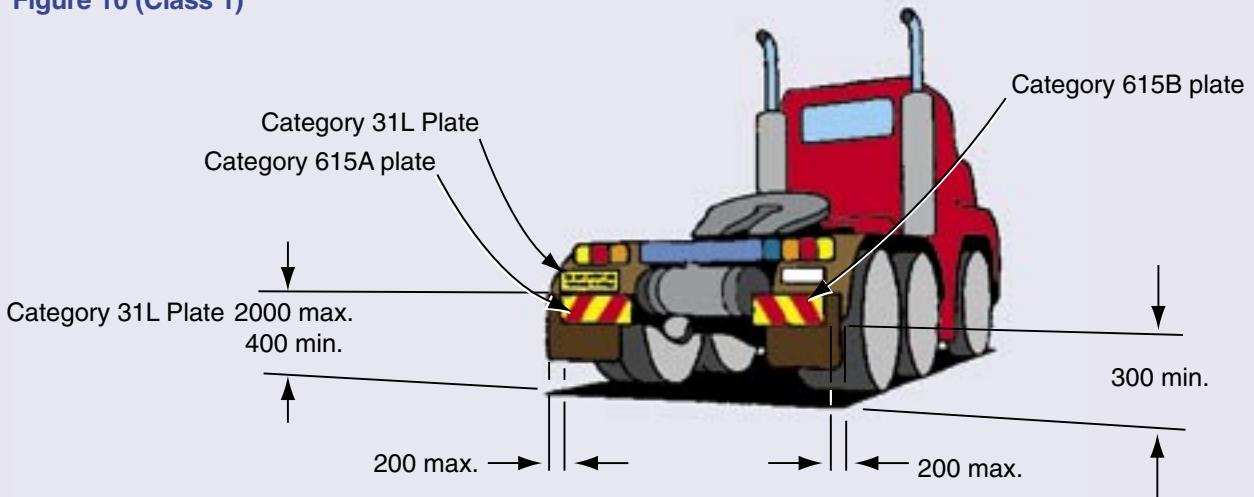

Figure 10 (Class 1)



Installation of rear marking plates made from Class 2 material

Figure 11 (Class 2)

(all dimensions in millimetres)

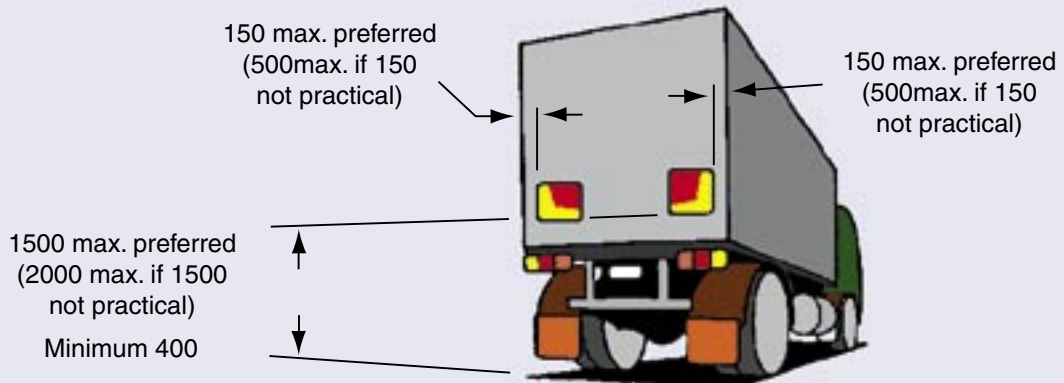

Figure 12 (Class 2)

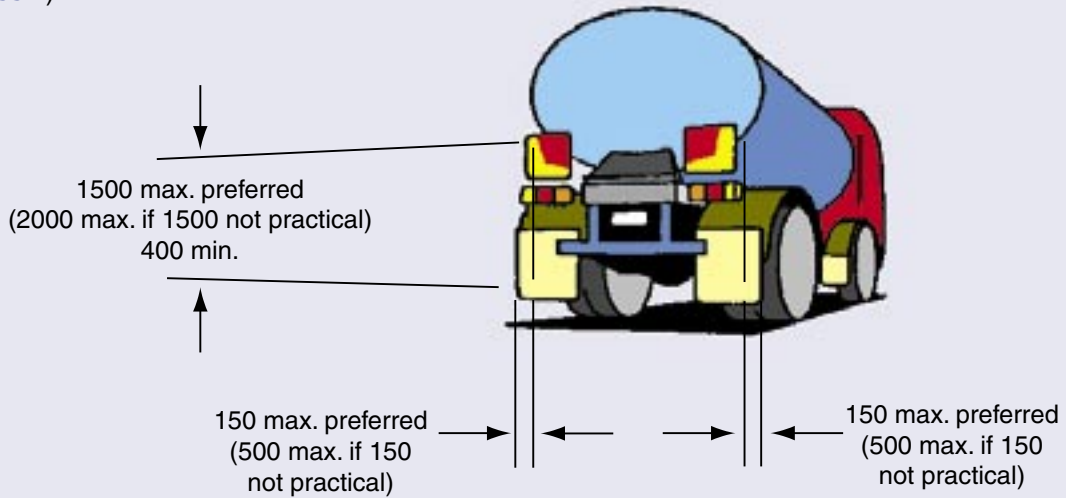

Figure 13 (Class 2)



Showing typical fitting of alternative style class 2 plate (type 1)

REMEMBER

- ✓ Only use rear marking plates made with approved retroreflective material.
- ✓ Keep the plates clean and in good condition.
- ✓ Plates must not be obscured by other parts of the vehicle, load or tarpaulins.



Turning Vehicle Sign

If your vehicle (meaning the towing vehicle together with the trailer and projecting load) is 7.5 metres long or longer, you may have the sign “Do not overtake turning vehicle” displayed at the rear of the rearmost vehicle. This can be either a separate sign or the words can be incorporated on either the left hand marking plate only, or both left and right plates. By having this sign attached to the rear of your vehicle, other following vehicles must give way to you.



Please note that if your vehicle (meaning the towing vehicle together with the trailer and projecting load) needs to straddle lanes or turn from an adjacent lane in order to turn left or right at intersections, and it is 7.5 metres long or longer, you must have the sign “DO NOT OVERTAKE TURNING VEHICLE”. Not having “DO NOT OVERTAKE TURNING VEHICLE” sign on these vehicles is illegal.

The “DO NOT OVERTAKE TURNING VEHICLE” sign must not be displayed in certain jurisdictions where a vehicle (or combination) is less than 7.5m long.