



# INSTALLATION INSTRUCTIONS

## A80UH2EK & 80G2UHE(L)K

Warm Air Gas Furnace  
Upflow/Horizontal  
Left/Right Air Discharge

This manual must be left with the homeowner for future reference.



This is a safety alert symbol and should never be ignored. When you see this symbol on labels or in manuals, be alert to the potential for personal injury or death.

### WARNING

Improper installation, adjustment, alteration, service or maintenance can cause property damage, personal injury or loss of life. Installation and service must be performed by a licensed professional installer (or equivalent), service agency or the gas supplier.

### CAUTION

As with any mechanical equipment, personal injury can result from contact with sharp sheet metal edges. Be careful when you handle this equipment.

### A80UH2EK & 80G2UHE(L)K Gas Furnace

The A80UH2EK & 80G2UHE(L)K gas furnace is shipped ready for installation in the upflow or horizontal right position (for horizontal left position the combustion air pressure switch must be moved). The furnace is shipped with the bottom panel in place. The bottom panel must be removed if the unit is to be installed in a horizontal application. The panel may also be removed in upflow applications.

Manufactured By  
Allied Air Enterprises LLC  
215 Metropolitan Drive  
West Columbia, SC 29170

### Table of Contents

A80UH2EK & 80G2UHE(L)K Gas Furnace.....	1
Unit Dimensions .....	2
Parts Arrangement.....	3
Shipping and Packing List.....	4
Safety Information .....	4
General.....	6
Combustion, Dilution & Ventilation Air .....	6
Setting Equipment.....	8
Filters.....	11
Duct System .....	12
Venting.....	13
Gas Piping.....	20
Electrical.....	22
Ignition Control .....	29
Ignition Control Diagnostic Codes .....	30
Non-Low GWP Applications .....	32
Integrated Control DIP Switch Settings .....	35
On-Board Links and Diagnostic Push Button .....	35
Unit Start-Up.....	36
Other Unit Adjustments.....	39
Heating Sequence of Operation .....	39
Service.....	40
Repair Parts List.....	42
Blower Performance .....	43

### WARNING

This furnace is equipped with an ignition control factory enabled for use with Allied A2L refrigerant systems. Disabling the refrigerant detection functionality on A2L system is prohibited by safety codes. Refer to furnace installation instructions for non-A2L and non-Allied refrigerant system setup.



(P) 508610-01

## Unit Dimensions

**NOTE** - C\*20 size units installed in upflow applications that require air volumes of 1800 cfm (850 L/s or greater) must have one of the following:

1. Single side return air with transition, to accommodate 20 x 25 x 1 in. (508 x 635 x 25 mm) air filter.
  2. Single side return air with optional RAB Return Air Base
  3. Bottom return air.
  4. Return air from both sides.
  5. Bottom and one side return air.
  6. Flue outlet may be horizontal but furnace must be vented vertically.
- Optional external side return air filter kit cannot be used with the optional RAB Return Air Base.

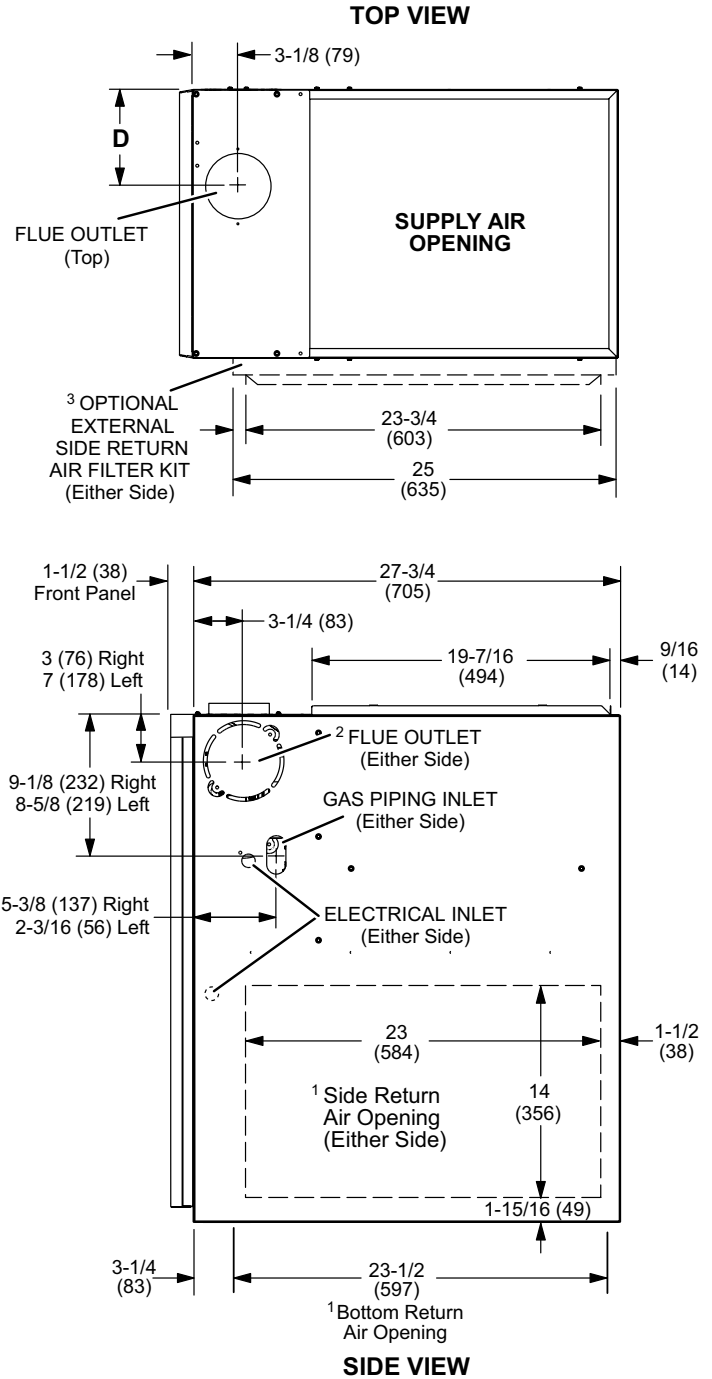
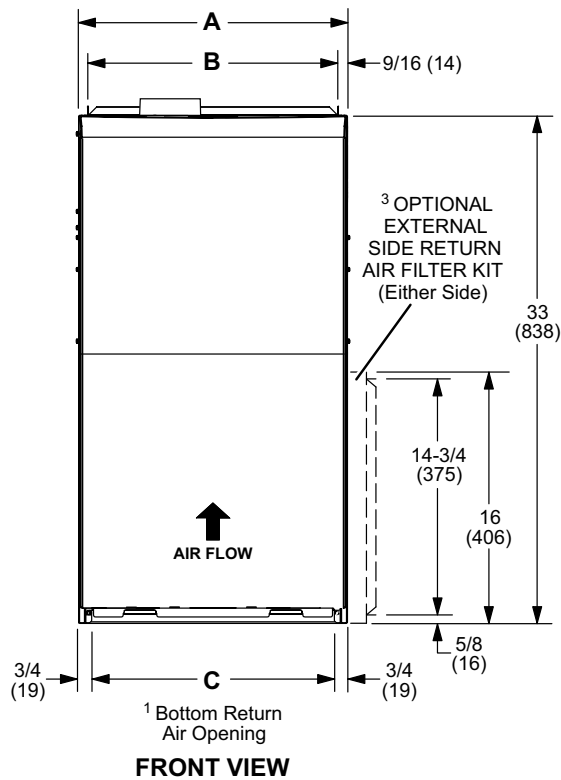

Model	Cooling Capacity	A		B		C		D	
		in.	mm	in.	mm	in.	mm	in.	mm
045-A	3 ton	14-1/2	368	13-3/8	340	13	330	4-3/4	121
070-A(L)	3 ton								
090-B	3 ton	17-1/2	446	16-3/8	416	16	406	6-1/4	159
090-B(L)	4 ton								
110-C	4 ton	21	533	19-7/8	504	19-1/2	495	8	203
110-C(L)	5 ton								

# Parts Arrangement

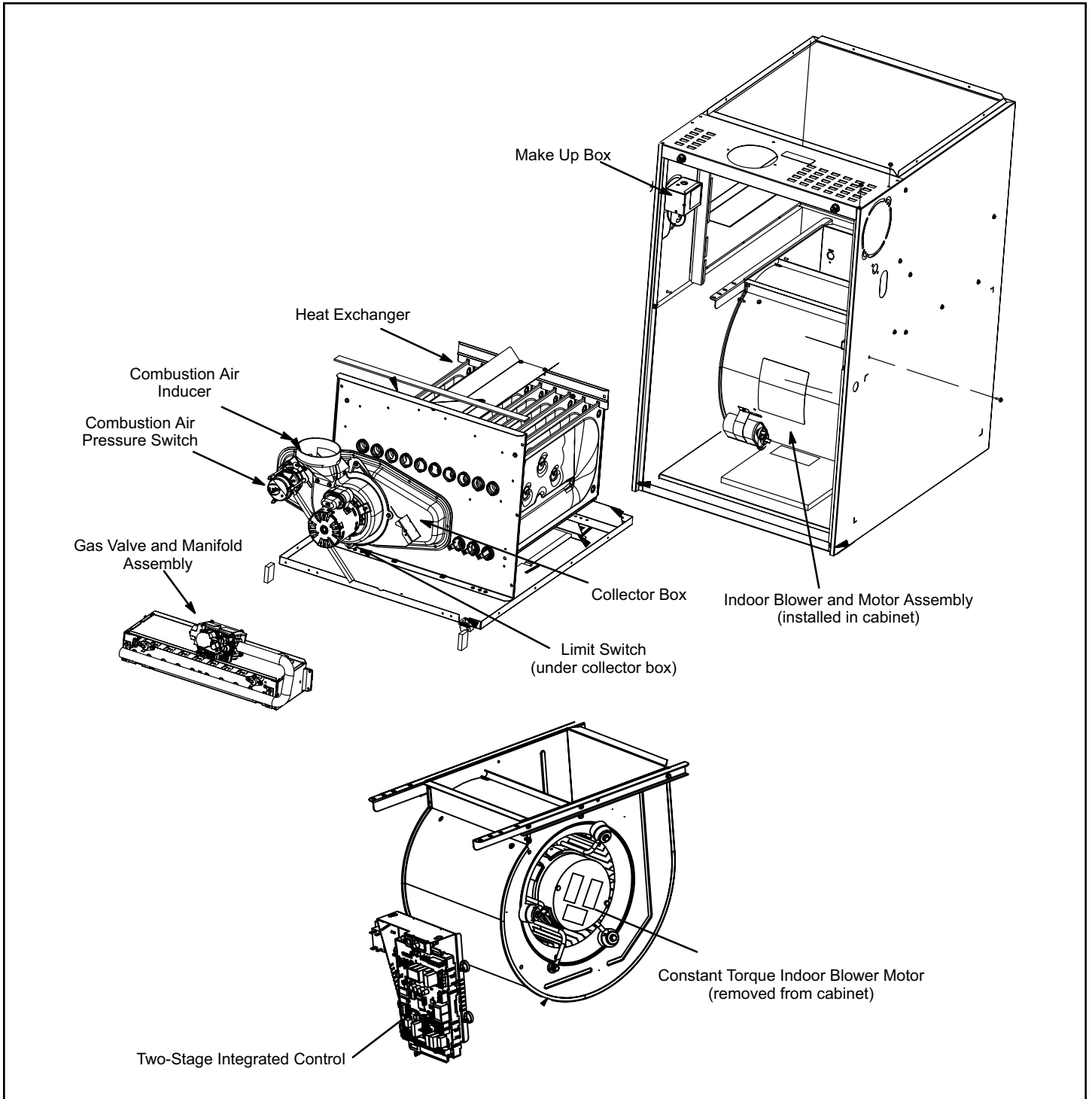

Figure 1.

## Shipping and Packing List

- 1 - Assembled Gas Furnace
- 1 - Bag assembly containing the following:
  - 2 - Screws
  - 1 - Snap bushing
  - 1 - Snap plug
  - 1 - Wire tie
  - 1 - Vent warning label
  - 1 - Owner's manual and warranty card

The following items may be ordered separately:

- 1 - Thermostat
- 1 - LP / Propane changeover kit
- 1 - Return air base
- 1 - High altitude kit
- 1 - Side filter kit

RDS Sensor kit can be ordered separately and is field installed.

Check equipment for shipping damage. If you find any damage, immediately contact the last carrier.

## Safety Information

### DANGER

#### DANGER OF EXPLOSION!

There are circumstances in which odorant used with LP/Propane gas can lose its scent. In case of a leak, LP/Propane gas will settle close to the floor and may be difficult to smell. An LP/Propane leak detector should be installed in all LP applications.

### CAUTION

As with any mechanical equipment, personal injury can result from contact with sharp sheet metal edges. Be careful when you handle this equipment.

### WARNING

Improper installation, adjustment, alteration, service or maintenance can cause property damage, personal injury or loss of life. Installation and service must be performed by a licensed professional installer (or equivalent), service agency or the gas supplier.

## Certifications

These units are CSA International certified to ANSI Z21.47.

In the USA, installation of gas furnaces must conform with local building codes. In the absence of local codes, units must be installed according to the current National Fuel Gas Code (ANSI-Z223.1). The National Fuel Gas Code is available from the following address.

American National Standards Institute, Inc.  
11 West 42nd Street  
New York, NY 10036

## Clearances

Adequate clearance must be made around the air openings into the vestibule area. In order to ensure proper unit operation, combustion and ventilation air supply must be provided according to the current National Fuel Gas Code. Vent installations must be consistent with the venting tables (in this instruction) and applicable provisions of local building codes.

This furnace is CSA International certified for installation clearances to combustible material as listed on the unit nameplate and in the tables in Figure 8 and Figure 13. Accessibility and service clearances must take precedence over fire protection clearances.

**NOTE:** For installation on combustible floors, the furnace shall not be installed directly on carpeting, tile, or other combustible material other than wood flooring.

## Installed Locations

For installation in a residential garage, the furnace must be installed so that the burner(s) and the ignition source are located no less than 18 inches (457 mm) above the floor. The furnace must be located or protected to avoid physical damage by vehicles. When a furnace is installed in a public garage, hangar, or other building that has a hazardous atmosphere, the furnace must be installed according to recommended good practice requirements and current National Fuel Gas Code.

## Temperature Rise

**NOTE:** Furnace must be adjusted to obtain a temperature rise within the range specified on the unit nameplate. Failure to do so may cause erratic limit operation and may result in premature heat exchanger failure.

This furnace must be installed so that its electrical components are protected from water.

## Installed in Combination with a Cooling Coil

When this furnace is used with cooling units, it shall be installed in parallel with, or on the upstream side of, cooling units to avoid condensation in the heating compartment. See Figure 2. With a parallel flow arrangement, a damper (or other means to control the flow of air) must adequately prevent chilled air from entering the furnace. If the damper is manually operated, it must be equipped to prevent operation of either the heating or the cooling unit, unless it is in the full HEAT or COOL setting. See Figure 2.

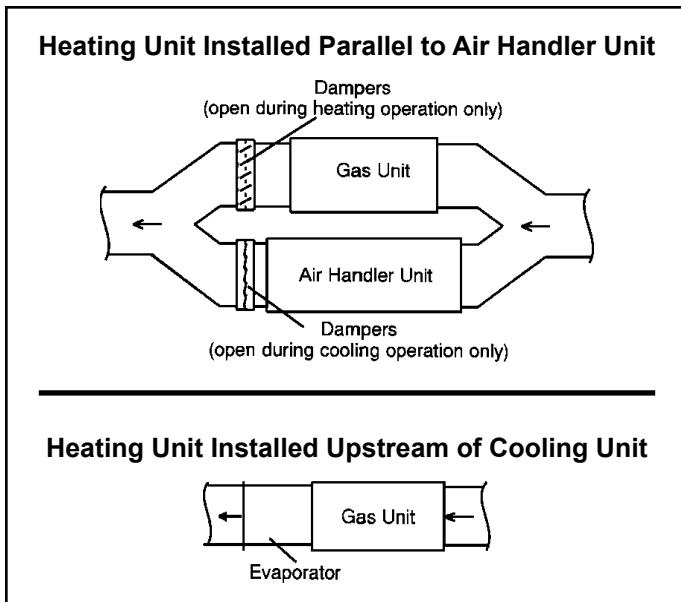

**Figure 2.**

When installed, this furnace must be electrically grounded according to local codes. In addition, in the United States, installation must conform with the current National Electric Code, ANSI/NFPA No. 70. The National Electric Code (ANSI/NFPA No. 70) is available from the following address.

National Fire Protection Association  
1 Battery March Park  
Quincy, MA 02269

**NOTE:** This furnace is designed for a minimum continuous return air temperature of 60° F (16°C) or an intermittent operation down to 55° F (13°C) dry bulb for cases where a night setback thermostat is used. Return air temperature must not exceed 85° F (29°C) dry bulb.

This furnace may be installed in alcoves, closets, attics, basements, garages, crawl spaces and utility rooms in the upflow or horizontal position.

**This furnace design has not been CSA certified for installation in mobile homes, recreational vehicles, or outdoors.**

#### **Use of Furnace as a Construction Heater**

Units may be used for heating of buildings or structures under construction, if the following conditions are met to ensure proper operation.

**DO NOT USE THE UNIT FOR CONSTRUCTION HEAT UNLESS ALL OF THE FOLLOWING CRITERIA ARE MET:**

- a. Furnace must be in its final location. The vent system must be permanently installed per these installation instructions.
- b. Furnace must be installed as a two pipe system and one hundred percent (100%) outdoor air must be provided for combustion air requirements during construction.

- c. A room thermostat must control the furnace. The use of fixed jumpers that will provide continuous heating is prohibited.
- d. The input rate and temperature rise must be set per the furnace rating plate.
- e. Supply and Return air ducts must be provided and sealed to the furnace. Return air must be terminated outside of the space where furnace is installed.
- f. Return air temperature range between 60°F (16°C) and 80°F (27°C) must be maintained.
- g. MERV 11 or greater air filters must be installed in the system and must be regularly inspected and maintained (e.g., regular static checks and replaced at end of life) during construction.
- h. Blower and vestibule access panels must be in place on the furnace at all times.
- i. The furnace heat exchanger, components, duct system, and evaporator coils must be thoroughly cleaned following final construction clean-up.
- j. Air filters must be replaced upon construction completion.
- k. All furnace operating conditions (including ignition, input rate, temperature rise and venting) must be verified in accordance with these installation instructions.
- l. The refrigerant leak detection sensor must be inspected for dust/debris deposits. Please refer to the evaporator coil and/or refrigerant detection sensor kit instructions for additional information.

EQUIPMENT MAY EXPERIENCE PREMATURE COMPONENT FAILURE AS A RESULT OF FAILURE TO FOLLOW THE ABOVE INSTALLATION INSTRUCTIONS. FAILURE TO FOLLOW THE ABOVE INSTALLATION INSTRUCTIONS VOIDS THE MANUFACTURER'S EQUIPMENT LIMITED WARRANTY. ALLIED AIR DISCLAIMS ALL LIABILITY IN CONNECTION WITH INSTALLER'S FAILURE TO FOLLOW THE ABOVE INSTALLATION INSTRUCTIONS.

NOTWITHSTANDING THE FOREGOING, INSTALLER IS RESPONSIBLE FOR CONFIRMING THAT THE USE OF CONSTRUCTION HEAT IS CONSISTENT WITH THE POLICIES AND CODES OF ALL REGULATING ENTITIES. ALL SUCH POLICIES AND CODES MUST BE ADHERED TO.

## General

These instructions are intended as a general guide and do not supersede local codes in any way. Consult authorities having jurisdiction before installation.

In addition to the requirements outlined previously, the following general recommendations must be considered when installing one of these furnaces:

- Place the furnace as close to the center of the air distribution system as possible. The furnace should also be located close to the chimney or vent termination point.
- Do not install the furnace where drafts might blow directly into it. This could cause improper combustion.
- Do not block the furnace combustion air openings with clothing, boxes, doors, etc. Air is needed for proper combustion and safe unit operation.
- When the furnace is installed in an attic or other insulated space, keep insulation away from the furnace.
- Please consult the manufacturer of your evaporator coil for their recommendations on distance required between the heat exchanger and their drain pan. Adequate space must be provided between the drain pan and the furnace heat exchanger.

**NOTE:** *The Commonwealth of Massachusetts stipulates these additional requirements:*

- Gas furnaces shall be installed by a licensed plumber or fitter only.
- The gas cock must be "T handle" type.
- When a furnace is installed in an attic, the passageway to and service area surrounding the equipment shall be floored.

## Combustion, Dilution & Ventilation Air

In the past, there was no problem in bringing in sufficient outdoor air for combustion. Infiltration provided all the air that was needed. In today's homes, tight construction practices make it necessary to bring in air from outside for combustion. Take into account that exhaust fans, appliance vents, chimneys, and fireplaces force additional air that could be used for combustion out of the house. Unless outside air is brought into the house for combustion, negative pressure (outside pressure is greater than inside pressure) will build to the point that a downdraft can occur in the furnace vent pipe or chimney. As a result, combustion gases enter the living space creating a potentially dangerous situation.

In the absence of local codes concerning air for combustion and ventilation, use the guidelines and procedures in this section to install these furnaces to ensure efficient and safe operation. You must consider combustion air needs and requirements for exhaust vents and gas piping.

A portion of this information has been reprinted with permission from the National Fuel Gas Code (ANSI-Z223.1). This reprinted material is not the complete and official position of the ANSI on the referenced subject, which is represented only by the standard in its entirety.

### CAUTION

Do not install the furnace in a corrosive or contaminated atmosphere. Meet all combustion and ventilation air requirements, as well as all local codes.

### WARNING

Insufficient combustion air can cause headaches, nausea, dizziness or asphyxiation. It will also cause excess water in the heat exchanger resulting in rusting and premature heat exchanger failure. Excessive exposure to contaminated combustion air will result in safety and performance related problems. Avoid exposure to the following substances in the combustion air supply:

- Permanent wave solutions
- Chlorinated waxes and cleaners
- Chlorine base swimming pool chemicals
- Water softening chemicals
- De-icing salts or chemicals
- Carbon tetrachloride
- Halogen type refrigerants
- Cleaning solvents (such as perchloroethylene)
- Printing inks, paint removers, varnishes, etc.
- Hydrochloric acid
- Antistatic fabric softeners for clothes dryers
- Masonry acid washing materials

All gas-fired appliances require air for the combustion process. If sufficient combustion air is not available, the furnace or other appliances will operate inefficiently and unsafely. Enough air must be provided to meet the needs of all fuel burning appliances and appliances such as exhaust fans which force air out of the house. When fireplaces, exhaust fans, or clothes dryers are used at the same time as the furnace, much more air is necessary to ensure proper combustion and to prevent a downdraft. Insufficient air causes incomplete combustion which can result in carbon monoxide.

In addition to providing combustion air, fresh outdoor air dilutes contaminants in the indoor air. These contaminants may include bleaches, adhesives, detergents, solvents and other contaminants which can corrode furnace components.

The requirements for providing air for combustion and ventilation depend largely on whether the furnace is installed in an unconfined or a confined space.

### Unconfined Space

An unconfined space is an area such as a basement or large equipment room with a volume greater than 50 cubic feet (1.42 m<sup>3</sup>) per 1,000 Btu (.29 kW) per hour of the combined input rating of all appliances installed in that space. This space also includes adjacent rooms which are not separated by a door.

Though an area may appear to be unconfined, it might be necessary to bring in outdoor air for combustion if the structure does not provide enough air by infiltration. If the furnace is located in a building of tight construction with weather stripping and caulking around the windows and doors, follow the procedures in the air from outside section.

### Confined Space

A confined space is an area with a volume less than 50 cubic feet (1.42 m<sup>3</sup>) per 1,000 Btu (.29 kW) per hour of the combined input rating of all appliances installed in that space. This definition includes furnace closets or small equipment rooms.

When the furnace is installed so that supply ducts carry air circulated by the furnace to areas outside the space containing the furnace, the return air must be handled by ducts which are sealed to the furnace casing and which terminate outside the space containing the furnace. This is especially important when the furnace is mounted on a platform in a confined space such as a closet or small equipment room.

Even a small leak around the base of the unit at the platform or at the return air duct connection can cause a potentially dangerous negative pressure condition. Air for combustion and ventilation can be brought into the confined space either from inside the building or from outside.

### Air from Inside

If the confined space that houses the furnace adjoins a space categorized as unconfined, air can be brought in by providing two permanent openings between the two spaces. Each opening must have a minimum free area of 1 square inch (645 mm<sup>2</sup>) per 1,000 Btu (.29 kW) per hour of total input rating of all gas fired equipment in the confined space. Each opening must be at least 100 square inches (64516 mm<sup>2</sup>). One opening shall be within 12 inches (305 mm) of the top of the enclosure and one opening within 12 inches (305 mm) of the bottom. See Figure 3.

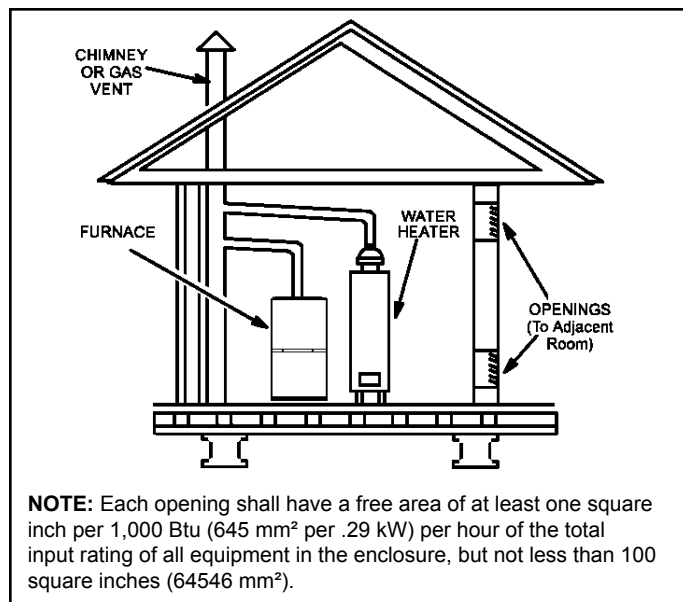
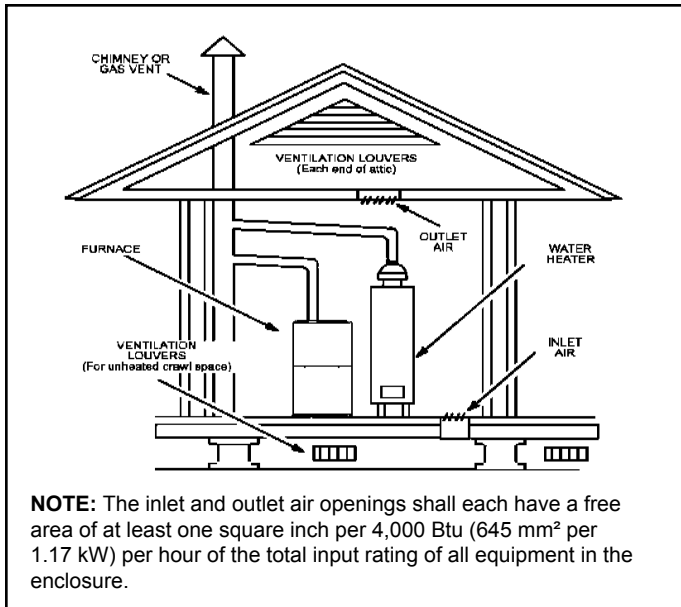

**Figure 3. Equipment in Confined Space - All Air From Inside**

### Air from Outside

If air from outside is brought in for combustion and ventilation, the confined space must have two permanent openings. One opening shall be within 12 inches (305 mm) of the top of the enclosure and one opening within 12 inches (305 mm) of the bottom. These openings must communicate directly or by ducts with the outdoors or spaces (crawl or attic) that freely communicate with the outdoors or indirectly through vertical ducts. Each opening shall have a minimum free area of 1 square inch (645 mm<sup>2</sup>) per 4,000 Btu (1.17 kW) per hour of total input rating of all equipment in the enclosure. See Figure 4 and Figure 5. When communicating with the outdoors through horizontal ducts, each opening shall have a minimum free area of 1 square inch (645 mm<sup>2</sup>) per 2,000 Btu (.56 kW) per total input rating of all equipment in the enclosure. See Figure 6.

When ducts are used, they shall be of the same cross sectional area as the free area of the openings to which they connect. The minimum dimension of rectangular air ducts shall be no less than 3 inches (75 mm). In calculating free area, the blocking effect of louvers, grilles, or screens must be considered. If the design and free area of protective covering is not known for calculating the size opening required, it may be assumed that wood louvers will have 20 to 25 percent free area and metal louvers and grilles will have 60 to 75 percent free area. Louvers and grilles must be fixed in the open position or interlocked with the equipment so that they are opened automatically during equipment operation.



**Figure 4. Equipment in Confined Space - All Air from Outside  
(Inlet Air from Crawl Space & Outlet Air to Ventilated Attic)**

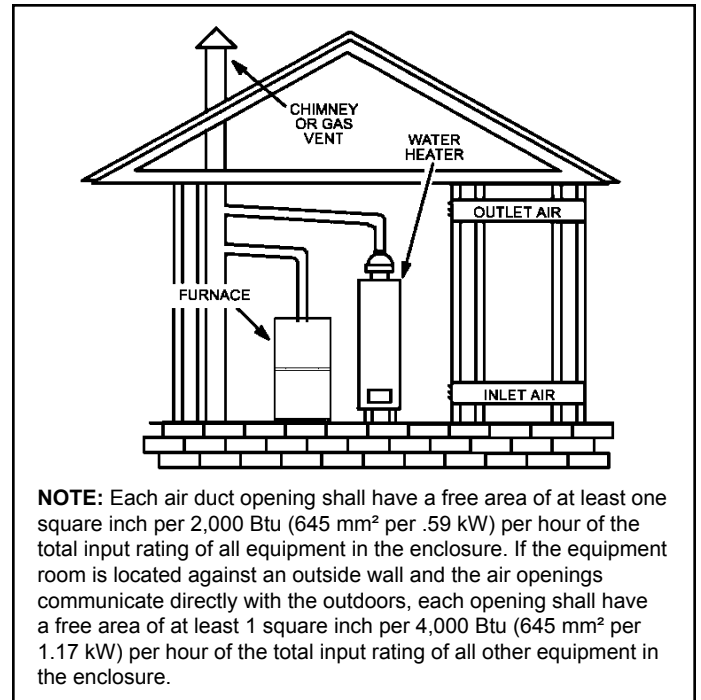

**Figure 6. Equipment in Confined Space - All Air from Outside**

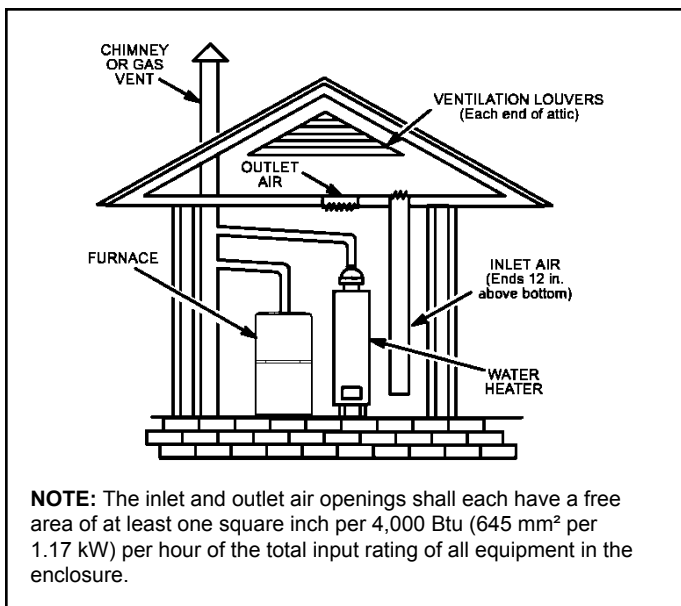

**Figure 5. Equipment in Confined Space - All Air from Outside  
(All Air through Ventilated Attic)**

### Setting Equipment

#### **⚠ WARNING**

Do not install the furnace on its front or its back. Do not connect the return air ducts to the back of the furnace. Doing so will adversely affect the operation of the safety control devices, which could result in personal injury or death.

The gas furnace can be installed as shipped in either the upflow position or the horizontal position.

Select a location that allows for the required clearances that are listed on the unit nameplate. Also consider gas supply connections, electrical supply, vent connection, and installation and service clearances [24 inches (610 mm) at unit front]. The unit must be level.

Units with 1/2 hp and 3/4 hp blower motors are equipped with three flexible legs and one rigid leg. See Figure 7. The rigid leg is equipped with a shipping bolt and a flat white plastic washer (rather than the rubber mounting grommet used with a flexible mounting leg). The bolt and washer must be removed before the furnace is placed into operation. After the bolt and washer have been removed, the rigid leg will not touch the blower housing.

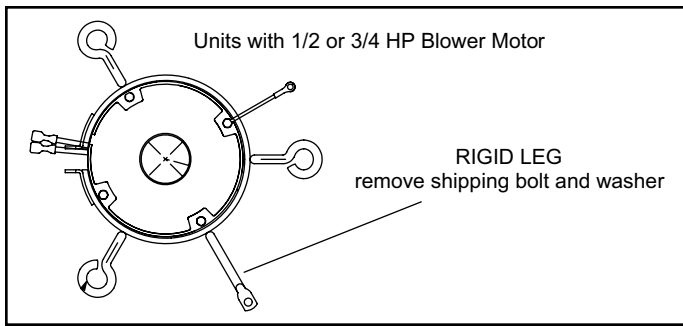

**Figure 7.**

**Upflow Applications**

Allow for clearances to combustible materials as indicated on the unit nameplate. Minimum clearances for closet or alcove installations are shown in Figure 8.

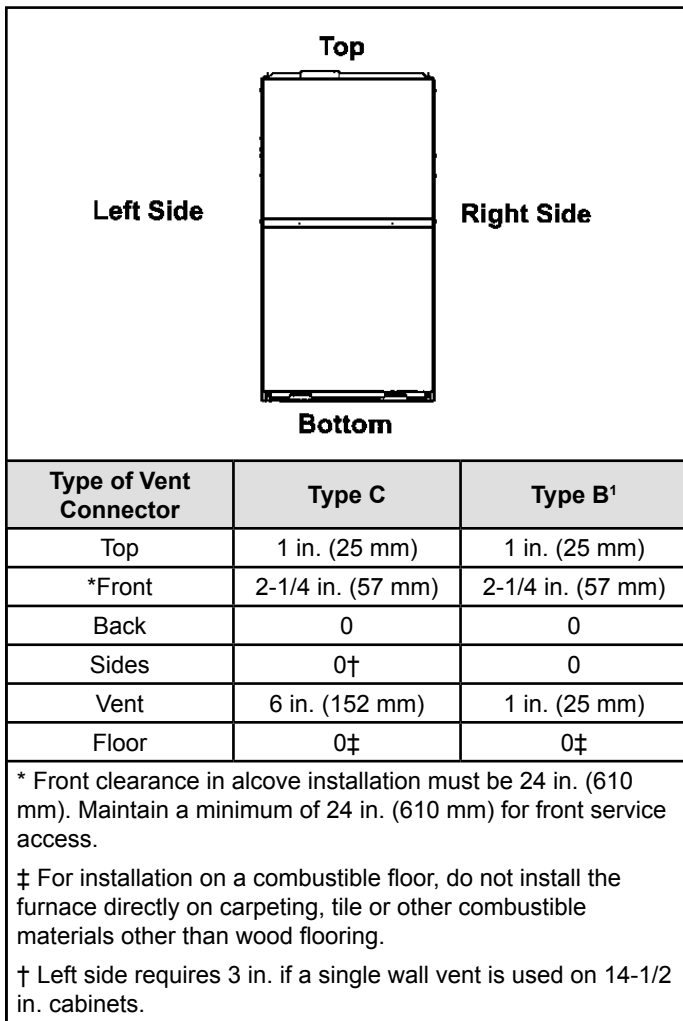

**Figure 8. Upflow Application Installation Clearances**

**Return Air - Upflow Applications**

Return air can be brought in through the bottom or either side of the furnace installed in an upflow application. If the furnace is installed on a platform with bottom return, make an airtight seal between the bottom of the furnace and the platform to ensure that the furnace operates properly and safely. The furnace is equipped with a removable bottom panel to facilitate installation.

Markings are provided on both sides of the furnace cabinet for installations that require side return air. Cut the furnace cabinet at the maximum dimensions shown on Page 2.

**NOTE:** C\*20 units that require air volumes over 1800 cfm (850 L/s) must have one of the following:

1. Single side return air with transition to accommodate 20 x 25 x 1 in. (508 x 635 x 25 mm) cleanable air filter. (Required to maintain proper air velocity.) See Figure 9.
2. Single side return air with optional return airbase. See Figure 9.
3. Bottom return air.
4. Return air from both sides.
5. Bottom and one side return air.

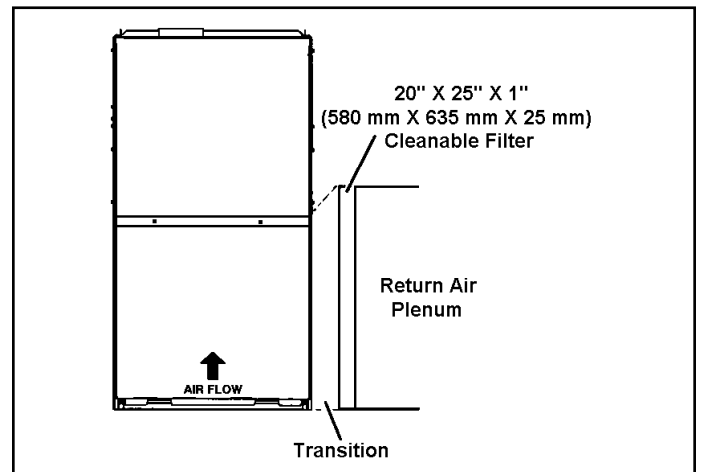

**Figure 9. Single Side Return Air (with transition and filter)**

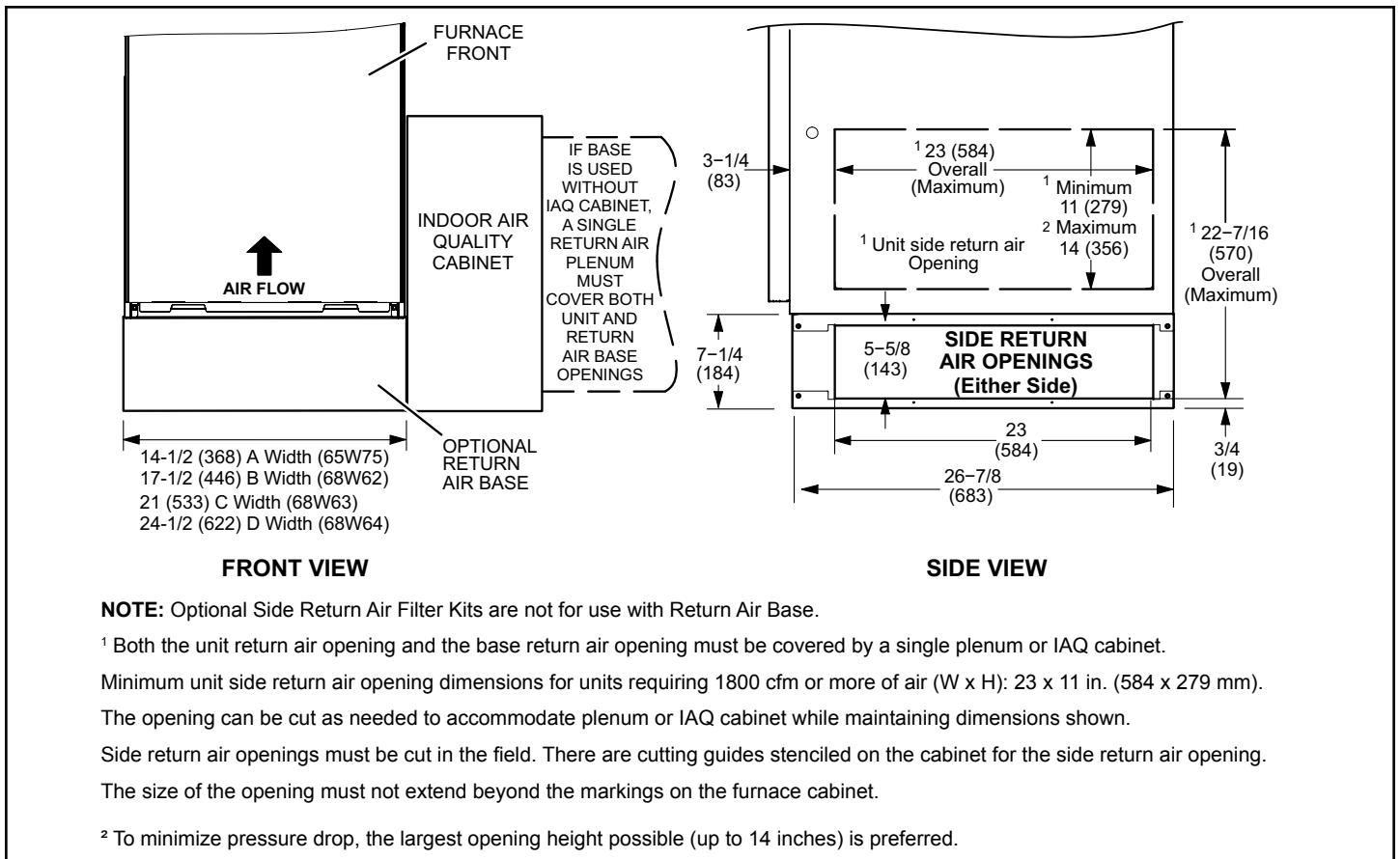

**Figure 10. Optional Return Air Base  
(Upflow Applications Only - For Use with A, B, C and D Cabinets)**

**Removing the Bottom Panel**

Remove the two screws that secure the bottom cap to the furnace. Pivot the bottom cap down to release the bottom panel. Once the bottom panel has been removed, reinstall the bottom cap. See Figure 11.

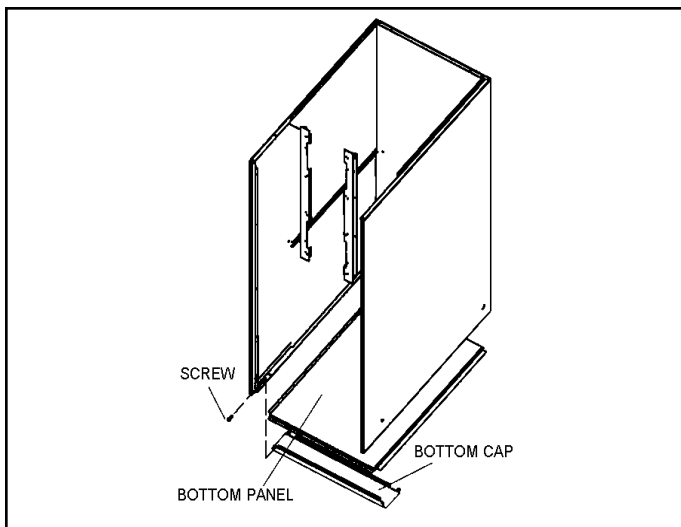

**Figure 11. Removing the Bottom Panel**

**Horizontal Applications**

The furnace can be installed in horizontal applications. Order horizontal suspension kit (51W10) or use equivalent suspension method.

Allow for clearances to combustible materials as indicated on the unit nameplate. Minimum clearances for closet or alcove installations are shown in Figure 13.

This furnace may be installed in either an attic or a crawl space. Either suspend the furnace from roof rafters or floor joists, as shown in Figure 12, or install the furnace on a platform, as shown in Figure 14.

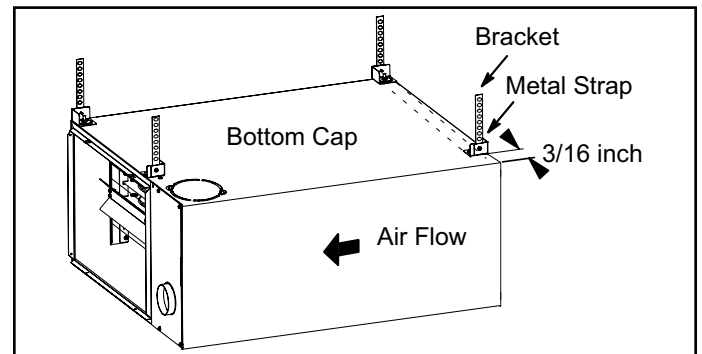

**Figure 12. Typical Horizontal Application Unit  
Suspended in Attic or Crawl Space**

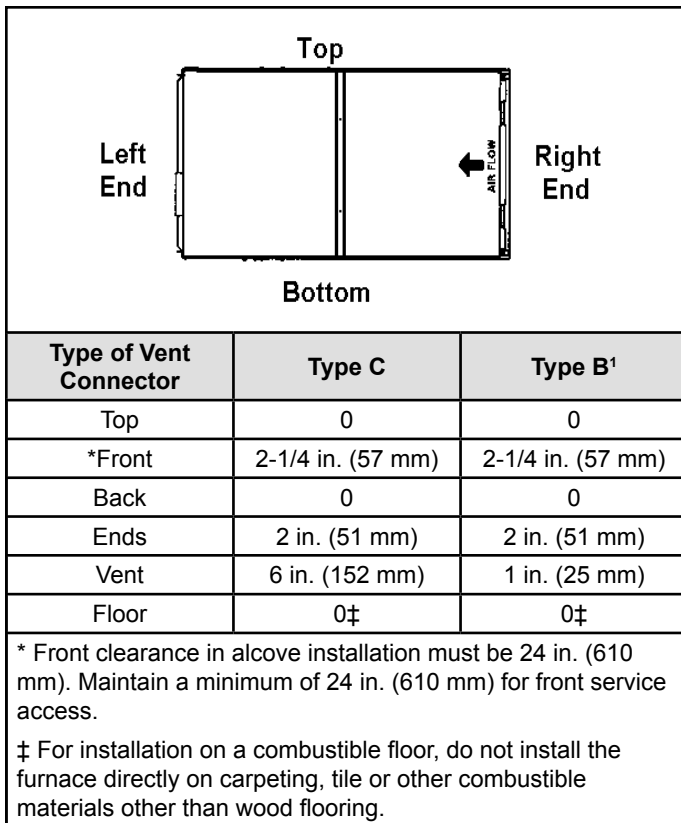

**Figure 13. Horizontal Application Installation Clearances**

**NOTE:** Heavy gauge perforated sheet metal straps may be used to suspend the unit from roof rafters or ceiling joists. When straps are used to suspend the unit in this way, support must be provided for both the ends. The straps must not interfere with the plenum or exhaust piping installation. Cooling coils and supply and return air plenums must be supported separately.

**NOTE:** When the furnace is installed on a platform in a crawlspace, it must be elevated enough to avoid water damage and to allow the evaporator coil to drain.

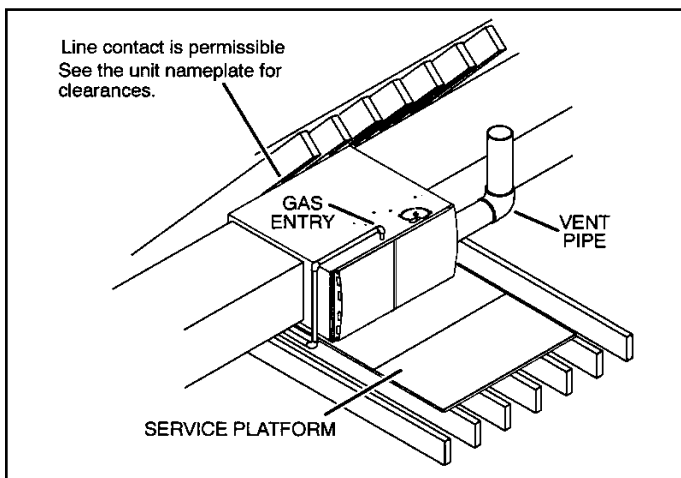

**Figure 14. Horizontal Application Unit Installed on Platform**

**Return Air - Horizontal Applications**

Return air must be brought in through the end of a furnace installed in a horizontal application. The furnace is equipped with a removable bottom panel to facilitate installation. See Figure 11.

**CAUTION**

If this unit is being installed in a space serviced by an exhaust fan, power exhaust fan, or other device which may create a negative pressure in the space, take care when sizing the inlet air opening. The inlet air opening must be sized to accommodate the maximum volume of exhausted air as well as the maximum volume of combustion air required for all gas appliances serviced by this space.

**WARNING**

Improper installation of the furnace can result in personal injury or death. Combustion and flue products must never be allowed to enter the return air system or the living space. Use screws and joint tape to seal the return air system to the furnace.

In platform installations with bottom return air, the furnace should be sealed airtight to the return air plenum. A door must never be used as a portion of the return air duct system. The base must provide a stable support and an airtight seal to the furnace. Allow absolutely no sagging, cracks, gaps, etc..

The return and supply air duct systems must never be connected to or from other heating devices such as a fireplace or stove, etc.. Fire, explosion, carbon monoxide poisoning, personal injury and/or property damage could result.

**WARNING**

The inner blower panel must be securely in place when the blower and burners are operating. Gas fumes, which could contain carbon monoxide, can be drawn into living space resulting in personal injury or death.

**Filters**

This unit is not equipped with a filter or rack. A field provided high velocity filter is required for the unit to operate properly. Table 1 lists recommended filter sizes.

## ⚠ WARNING

If a high-efficiency filter is being installed as part of this system to ensure better indoor air quality, the filter must be properly sized. High-efficiency filters have a higher static pressure drop than standard efficiency glass/foam filters. If the pressure drop is too great, system capacity and performance may be reduced. The pressure drop may also cause the limit to trip more frequently during the winter and the indoor coil to freeze in the summer, resulting in an increase in the number of service calls.

Before using any filter with this system, check the specifications provided by the filter manufacturer against the data given in the appropriate Technical Specification.

**Table 1.**

Furnace Cabinet Width	Filter Size	
	Side Return	Bottom Return
A - 14-1/2"	16 x 25 x 1	14 x 25 x 1
B - 17-1/2"		16 x 25 x 1
C - 21"		20 x 25 x 1

## Duct System

Use industry approved standards (such as those published by Air Conditioning Contractors of America or American Society of Heating, Refrigerating and Air Conditioning Engineers) to size and install the supply and return air duct system. This will result in a quiet and low static system that has uniform air distribution.

**NOTE:** Do not operate the furnace in the heating mode with an external static pressure that exceeds 0.8 inches w.c. Higher external static pressures may cause erratic limit operation.

## Supply Air Plenum

If the furnace is installed without a cooling coil, a removable access panel must be installed in the supply air duct. The access panel should be large enough to permit inspection (either by smoke or reflected light) of the heat exchanger for leaks after the furnace is installed. The furnace access panel must always be in place when the furnace is operating and it must not allow leaks into the supply air duct system. Install self tapping screws in the three evaporator coil screw holes made for horizontal applications to seal the top cap to the vestibule panel.

## Return Air Plenum

**NOTE:** Return air must not be drawn from a room where this furnace, or any other gas fueled appliance (i.e., water heater), or carbon monoxide producing device (i.e., wood fireplace) is installed.

When return air is drawn from a room, a negative pressure is created in the room. If a gas appliance is operating in a room with negative pressure, the flue products can be pulled back down the vent pipe and into the room. This reverse flow of the flue gas may result in incomplete combustion and the formation of carbon monoxide gas. This toxic gas might then be distributed throughout the house by the furnace duct system.

In upflow applications, the return air can be brought in through the bottom or either side of the furnace. If a furnace with bottom return air is installed on a platform, make an airtight seal between the bottom of the furnace and the platform to ensure that the unit operates properly and safely. Use fiberglass sealing strips, caulking, or equivalent sealing method between the plenum and the furnace cabinet to ensure a tight seal. If a filter is installed, size the return air duct to fit the filter frame.

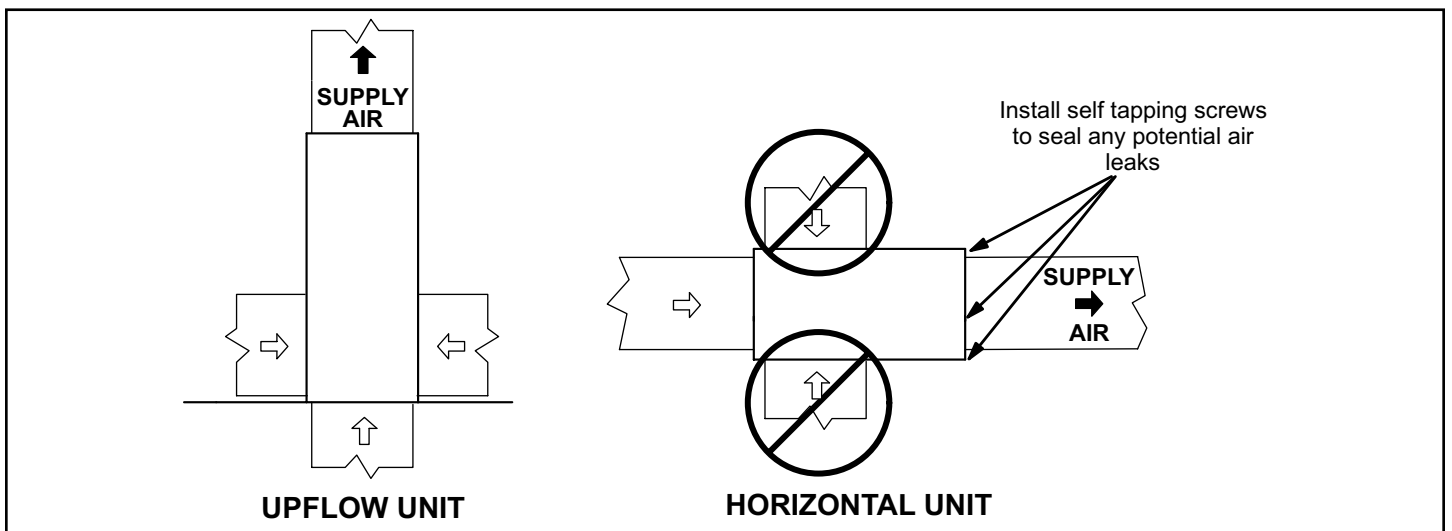
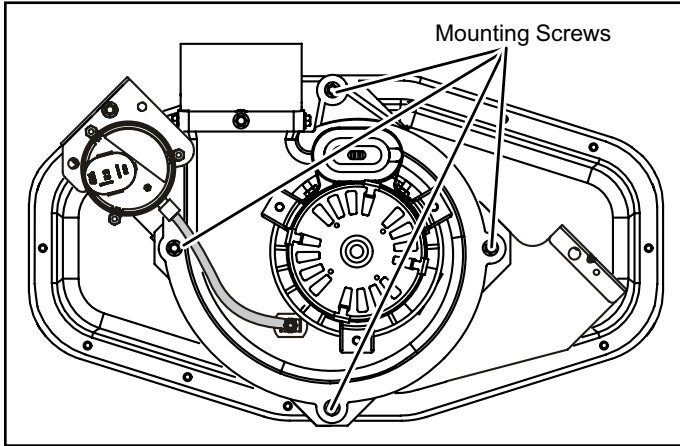

**Figure 15.**

## Venting

**NOTE:** For any Low GWP refrigerant systems with exposed line set joints installed in the same space, each non-direct vent furnace system must have a refrigerant detection sensor installed below the level of the burners (See "SECONDARY SENSOR REQUIREMENTS" on page 32). Any direct vent furnace system is not subject to this requirement.

A 4 inch diameter flue transition is factory installed on the combustion air inducer outlet of all models. Figure 17 shows the combustion air inducer as shipped from the factory.



**Figure 16. Mounting Screws Location**

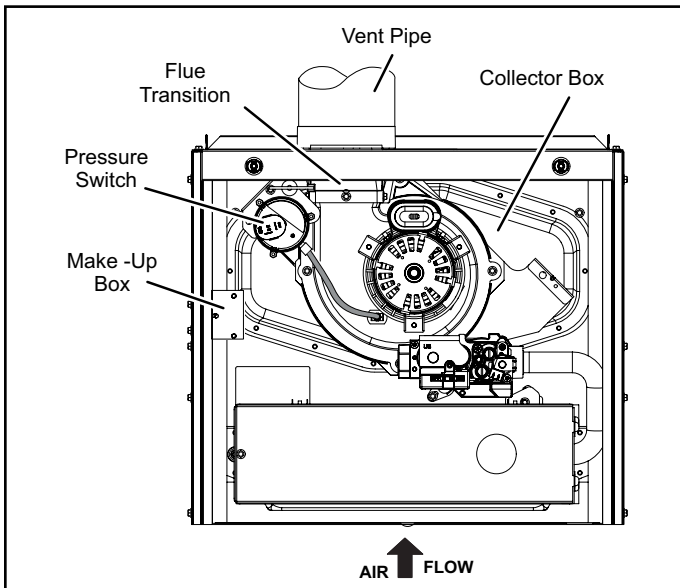

**Figure 17. Upflow Position  
Top Vent Discharge**

## **▲ IMPORTANT**

The unit will not vent properly with the flue transition pointed down in the 6 o'clock position. The combustion air inducer may be rotated clockwise or counterclockwise by 90° to allow for top or side vent discharge in all applications. When the unit is installed, the flue transition must be in the 9 o'clock, 12 o'clock or 3 o'clock position.

If necessary reposition the combustion air inducer, pressure switch and/or make-up box as needed per the following steps. See Figure 18 through Figure 23.

2. Remove the four mounting screws which secure the combustion air inducer / pressure switch assembly to the orifice plate. See Figure 16. Lift and rotate the assembly 90 degrees clockwise or counter clockwise to either the 3 o'clock position or to 9 o'clock position and re-secure with four screws. Gasket should be left in place.
3. Use tin snips to cut preferred opening on the cabinet for repositioning the flue outlet. Use the cut-out piece as a cover plate to patch unused opening on cabinet.

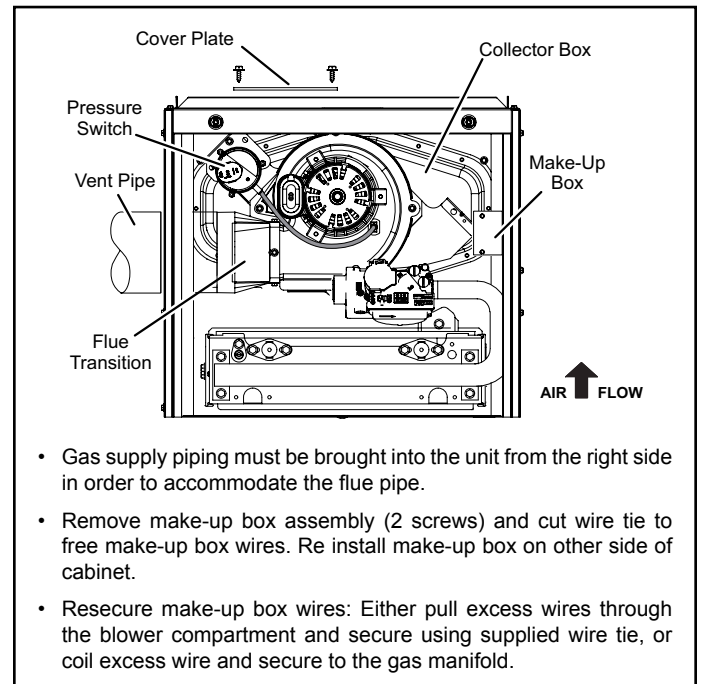

**Figure 18. Upflow Position  
Left Side Vent Discharge**

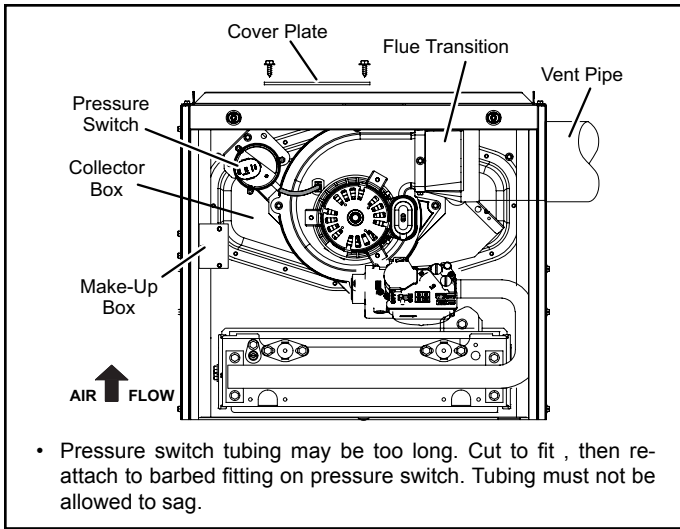

**Figure 19. Upflow Position  
Right Side Vent Discharge**

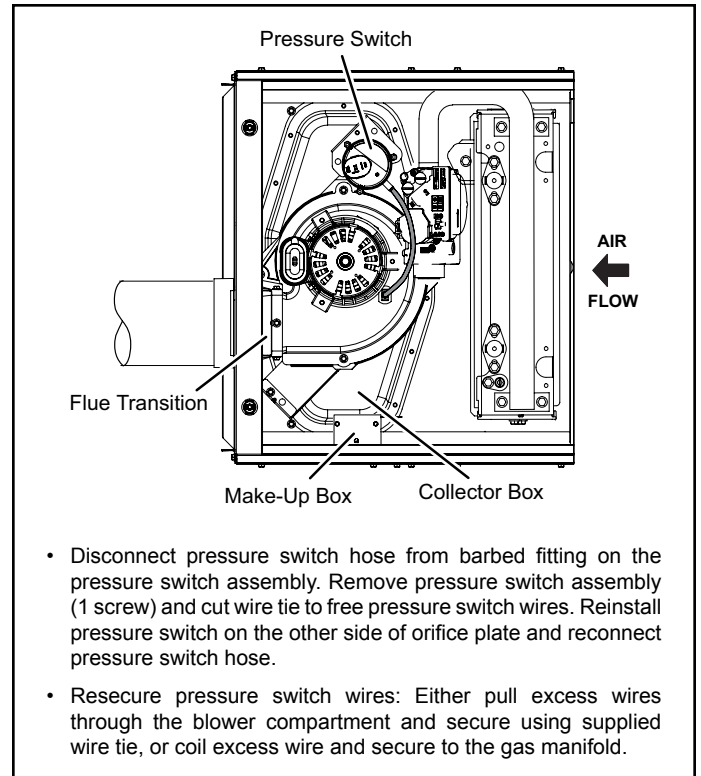

**Figure 21. Horizontal Left Position  
Side Vent Discharge**

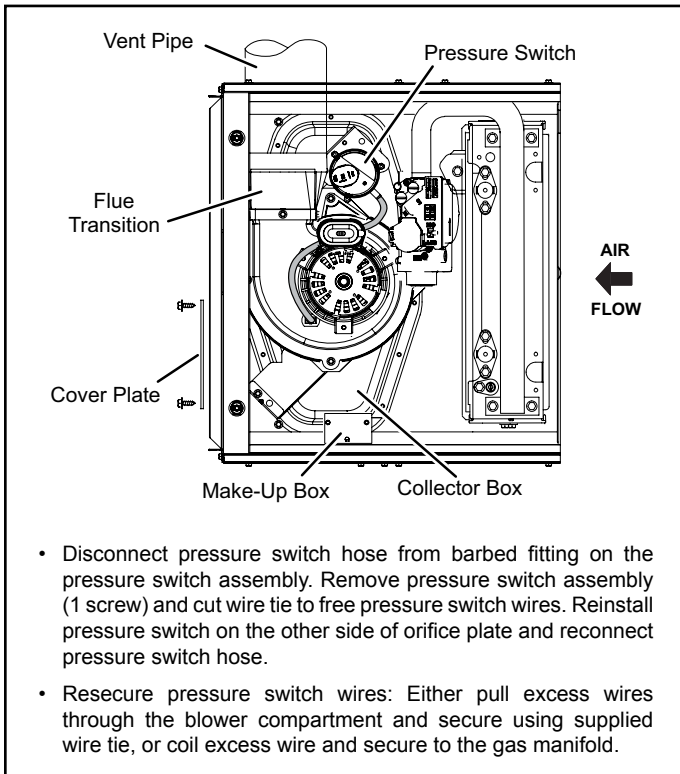

**Figure 20. Horizontal Left Position  
Top Vent Discharge**

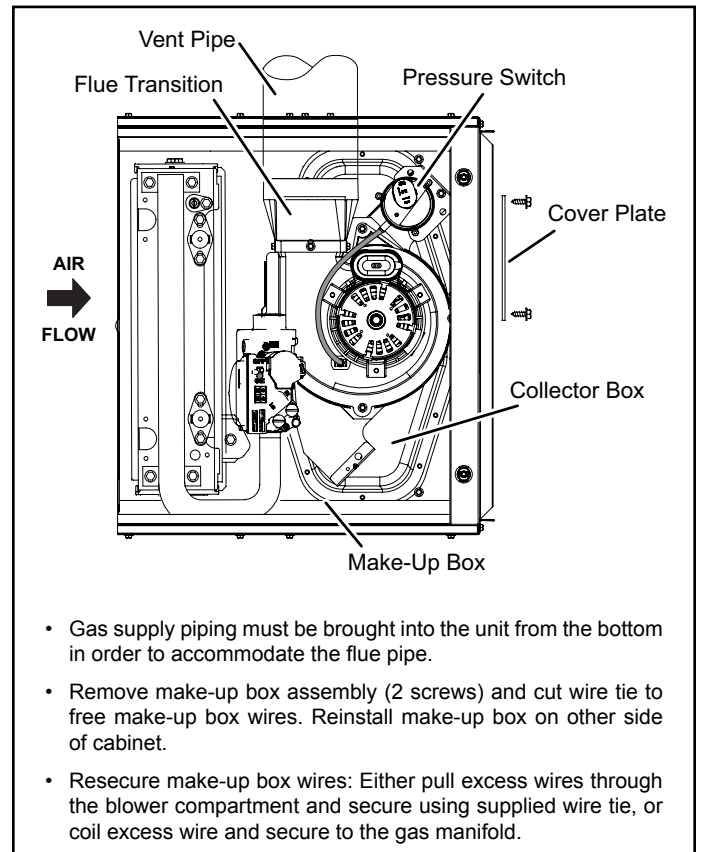

**Figure 22. Horizontal Right Position  
Top Vent Discharge**

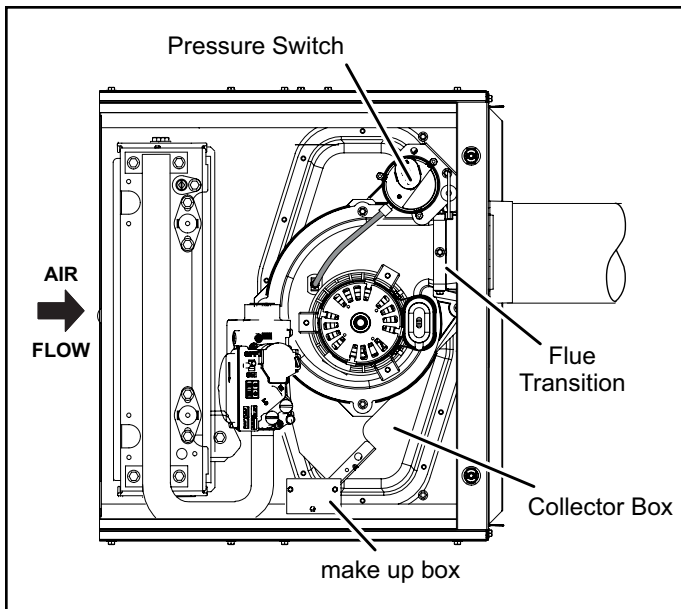

**Figure 23. Horizontal Right Position Side Vent Discharge**

These series units are classified as fan assisted Category I furnaces when vertically vented according to the latest edition of National Fuel Gas Code (NFPA 54 / ANSI Z223.1) in the USA. A fan assisted Category I furnace is an appliance equipped with an integral mechanical means to either draw or force combustion products through the combustion chamber and/or heat exchanger. This unit is not approved for use with horizontal venting.

**NOTE:** Use these instructions as a guide. They do not supersede local codes. This furnace must be vented according to all local codes these installation instructions, and the provided venting tables in these instructions.

The venting tables in this manual were extracted from the National Fuel Gas Code (NFPA 54 / ANSI Z223.1) and are provided as a guide for proper vent installation. Proper application, termination, construction and location of vents must conform to local codes having jurisdiction. In the absence of local codes, the NFGC serves as the defining document.

Refer to the tables and the venting information contained in these instructions to properly size and install the venting system.

Use self drilling sheet metal screws or a mechanical fastener to firmly secure the vent pipe to the round collar of the flue transition. If self drilling screws are used to attach the vent pipe, it is recommended that three be used. Drive one self drilling screw through the front and one through each side of the vent pipe and collar. See Figure 24.

Install the first vent connector elbow at a minimum of six inches (152 mm) from the furnace vent outlet. See Figure 24.

## Venting Using a Masonry Chimney

The following additional requirements apply when a lined masonry chimney is used to vent this furnace.

Masonry chimneys used to vent Category I central furnaces must be either tile lined or lined with a listed metal lining system or dedicated gas vent. Unlined masonry chimneys are prohibited. See Figure 26 and Figure 25 for common venting.

A chimney with one or more sides exposed to the outside of the structure is considered to be an exterior chimney. An exterior masonry chimney that is not tile-lined must be lined with B1 vent or a listed insulated flexible metal vent. An exterior tile-lined chimney that is sealed and capped may be lined with a listed uninsulated flexible metal vent. If the existing chimney will not accommodate a listed metal liner, either the chimney must be rebuilt to accommodate one of these liners or an alternate approved venting method must be found.

Insulation for the flexible vent pipe must be an encapsulated fiberglass sleeve recommended by the flexible vent pipe manufacturer. See Figure 26.

### **⚠ IMPORTANT**

Once the venting system is installed, attach the "Disconnected Vent" warning sticker to a visible area of the plenum near the vent pipe. See Figure 24. The warning sticker is provided in the bag assembly. Order kit 66W04 for additional stickers.

### **⚠ WARNING**

Asphyxiation hazard. The exhaust vent for this furnace must be securely connected to the furnace flue transition at all times.

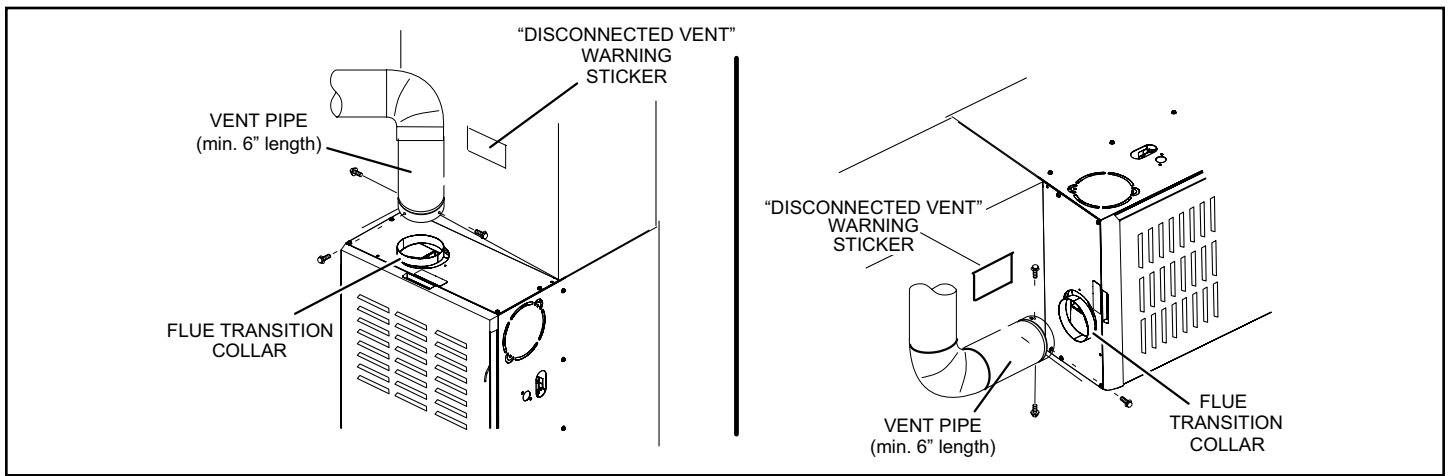

**Figure 24. Vent Connection Upflow and Horizontal Position**

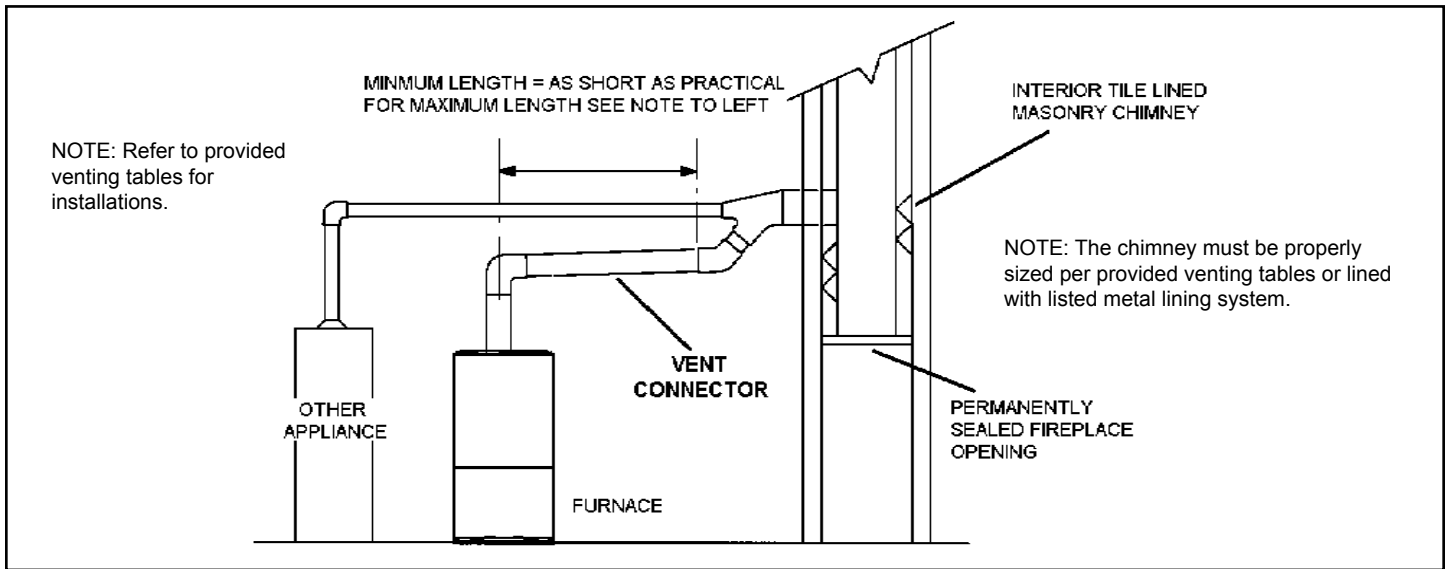

**Figure 25. Common Venting Using Tile Lined Interior Masonry Chimney and Combined Vent Connector**

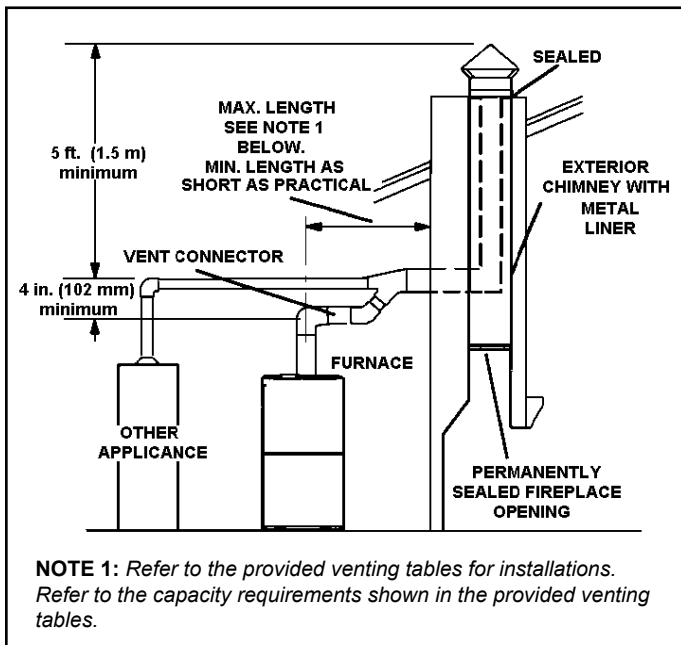

**Figure 26. Common Venting Using Metal-Lined Masonry Chimney**

**DO NOT** insulate the space between the liner and the chimney wall with puffed mica or any other loose granular insulating material.

**⚠ IMPORTANT**

SINGLE appliance venting of a fan assisted furnace into a tile lined masonry chimney (interior or outside wall) is prohibited. The chimney must first be lined with either type B1 vent or an insulated single wall flexible vent lining system which has been sized according to the provided venting tables and the vent pipe manufacturer's instructions.

A fan assisted furnace may be commonly vented into an existing lined masonry chimney if the following conditions are met:

- The chimney is currently serving at least one drafthood equipped appliance.
- The vent connectors and chimney are sized according to the provided venting tables.

If type B1 double wall vent is used inside a chimney, no other appliance can be vented into the chimney. The outer wall of type B1 vent pipe must not be exposed to flue products. A type B1 vent or masonry chimney liner shall terminate above the roof surface with a listed cap or a listed roof assembly according to the terms of their respective listings and the vent manufacturer's instructions.

When inspection reveals that an existing chimney is not safe for the intended purpose, it shall be rebuilt to conform to nationally recognized standards, lined or relined with suitable materials, or replaced with a gas vent or chimney suitable for venting. The chimney passageway must be checked periodically to ensure that it is clear and free of obstructions.

Do not install a manual damper, barometric draft regulator, or flue restrictor between the furnace and the chimney. Never connect a Category I appliance to a chimney that is servicing a solid-fuel appliance. If a fireplace chimney flue is used to vent this appliance, the fireplace opening must be permanently sealed.

A type B1 or listed chimney lining system that passes through an unused masonry chimney flue is not considered to be exposed to the outdoors.

### General Venting Requirements

Vent all furnaces according to these instructions:

1. Vent diameter recommendations and maximum allowable piping runs are found in the provided venting tables.
2. In no case should the vent or vent connector diameter be less than the diameter specified in the provided venting tables.
3. The minimum vent capacity determined by the sizing tables must be less than the low fire input rating and the maximum vent capacity must be greater than the high fire input rating.
4. Single appliance vents - If the vertical vent or tile lined chimney has a larger diameter or flow area than the vent connector, use the vertical vent diameter to determine the minimum vent capacity and the vent connector diameter to determine the maximum vent capacity. The flow area of the vertical vent, however, shall not exceed 7 times the flow area of the listed appliance categorized vent area, draft hood outlet area or flue collar area unless designed according to approved engineering methods.
5. Multiple appliance vents - The flow area of the largest section of vertical vent or chimney shall not exceed 7 times the smallest listed appliance categorized vent area, draft hood outlet area or flue collar area unless designed according to approved engineering methods.
6. The entire length of single wall metal vent connector shall be readily accessible for inspection, cleaning, and replacement.
7. Single appliance venting configurations with zero lateral lengths (Table 3) are assumed to have no elbows in the vent system. For all other vent configurations, the vent system is assumed to have two 90° elbows. For

each additional 90° elbow or equivalent (for example two 45° elbows equal one 90° elbow) beyond two, the maximum capacity listed in the venting table should be reduced by 10% (0.90 x maximum listed capacity).

8. The common venting tables (Table 4 and Table 5) were generated using a maximum horizontal vent connector length of 1-1/2 feet (.46 m) for each inch (25 mm) of connector diameter as follows:

**Table 2.**

Connector Diameter in. (mm)	Maximum Horizontal Connector Length ft. (m)
3 (76)	4-1/2 (1.37)
4 (102)	6 (1.83)
5 (127)	7-1/2 (2.29)
6 (152)	9 (2.74)
7 (178)	10-1/2 (3.20)

9. If the common vertical vent is offset, the maximum common vent capacity listed in the common venting tables should be reduced by 20%, the equivalent of two 90° elbows (0.80 x maximum common vent capacity). The horizontal length of the offset shall not exceed 1-1/2 feet (.46 m) for each inch (25 mm) of common vent diameter.
10. The vent pipe should be as short as possible with the least number of elbows and angles required to complete the job. Route the vent connector to the vent using the shortest possible route.
11. A vent connector shall be supported without any dips or sags and shall slope a minimum of 1/4 inch (6.4 mm) per linear foot (305 mm) of connector, back toward the appliance.
12. Vent connectors shall be firmly attached to the furnace flue collar by self drilling screws or other approved means, except vent connectors of listed type B vent material which shall be assembled according to the manufacturer's instructions. Joints between sections of single wall connector piping shall be fastened by screws or other approved means.
13. When the vent connector used for Category I appliances must be located in or pass through a crawl space, attic or other areas which may be cold, that portion of the vent connector shall be constructed of listed double wall type B vent material or material having equivalent insulation qualities.
14. All venting pipe passing through floors, walls, and ceilings must be installed with the listed clearance to combustible materials and be fire stopped according to local codes. In absence of local codes, refer to NFGC (2223.1).
15. No portion of the venting system can extend into, or pass through any circulation air duct or plenum.
16. Vent connectors serving Category I appliances shall not be connected to any portion of mechanical draft systems operating under positive pressure such as Category III or IV venting systems.
17. If vent connectors are combined prior to entering the

common vent, the maximum common vent capacity listed in the common venting tables must be reduced by 10%, the equivalent of one 90° elbow (0.90 x maximum common vent capacity).

18. The common vent diameter must always be at least as large as the largest vent connector diameter.
19. In no case, shall the vent connector be sized more than two consecutive table size diameters over the size of the draft hood outlet or flue collar outlet.
20. Do not install a manual damper, barometric draft regulator or flue restrictor between the furnace and the chimney.
21. When connecting this appliance to an existing dedicated or common venting system, you must inspect the venting system's general condition and look for signs of corrosion. The existing vent pipe size must conform to these instructions and the provided venting tables. If the existing venting system does not meet these requirements, it must be resized.

**Table 3.**

**Capacity of Type B Double Wall Vents with Type B Double Wall Connectors Serving a Single Category I Appliance**

Height H (feet)	Lateral L (feet)	Vent and Connector Diameter - D (inches)							
		3 inch		4 inch		5 inch		6 inch	
		Appliance Input Rating in Thousands of Btu per Hour							
		MIN	MAX	MIN	MAX	MIN	MAX	MIN	MAX
6	0	0	78	0	152	0	251	0	375
	2	13	51	18	97	27	157	32	232
	4	21	49	30	94	39	153	50	227
	6	25	46	36	91	47	149	59	223
8	0	0	84	0	165	0	276	0	415
	2	12	57	16	109	25	178	28	263
	5	23	53	32	103	42	171	53	255
	8	28	49	39	98	51	164	64	247
10	0	0	88	0	175	0	295	0	447
	2	12	61	17	118	23	194	26	289
	5	23	57	32	113	41	187	52	280
	10	30	51	41	104	54	176	67	267
15	0	0	94	0	191	0	327	0	502
	2	11	69	15	136	20	226	22	339
	5	22	65	30	130	39	219	49	330
	10	29	59	40	121	51	206	64	315
	15	35	53	48	112	61	195	76	301
20	0	0	97	0	202	0	349	0	540
	2	10	75	14	149	18	250	20	377
	5	21	71	29	143	38	242	47	367
	10	28	64	38	133	50	229	62	351
	15	34	58	46	124	59	217	73	337
	20	48	52	55	116	69	206	84	322
30	0	0	100	0	213	0	374	0	587
	2	9	81	13	166	14	283	18	432
	5	21	77	28	160	36	275	45	421
	10	27	70	37	150	48	262	59	405
	15	33	64	44	141	57	249	70	389
	20	56	58	53	132	66	237	80	374
	30	NA	NA	73	113	88	214	104	346

**NOTE:** Single appliance venting configurations with zero lateral lengths are assumed to have no elbows in the vent system. For all other vent configurations, the vent system is assumed to have two 90° elbows. For each additional 90° elbow or equivalent (for example two 45° elbows equal one 90° elbow) beyond two, the maximum capacity listed in the venting table should be reduced by 10 percent (0.90 x maximum listed capacity).

**Table 4.**

**Vent Connector Capacity**

**Type B Double Wall Vents with Type B Double Wall Connectors Serving Two or More Category I Appliances**

Vent Height H (feet)	Connector Rise R (feet)	Vent and Connector Diameter - D (inches)							
		3 inch		4 inch		5 inch		6 inch	
		Appliance Input Rating in Thousands of Btu per Hour							
		MIN	MAX	MIN	MAX	MIN	MAX	MIN	MAX
6	1	22	37	35	66	46	106	58	164
	2	23	41	37	75	48	121	60	183
	3	24	44	38	81	49	132	62	199
8	1	22	40	35	72	49	114	64	176
	2	23	44	36	80	51	128	66	195
	3	24	47	37	67	53	139	67	210
10	1	22	43	34	78	49	123	65	189
	2	23	47	36	86	51	136	67	206
	3	24	50	37	92	52	146	69	220
15	1	21	50	33	89	47	142	64	220
	2	22	53	35	96	49	153	66	235
	3	24	55	36	102	51	163	68	248
20	1	21	54	33	99	46	157	62	246
	2	22	57	34	105	48	167	64	259
	3	23	60	35	110	50	176	66	271
30	1	20	62	31	113	45	181	60	288
	2	21	64	33	118	47	190	62	299
	3	22	66	34	123	48	198	64	309

**Table 5.**

**Common Vent Capacity**

**Type B Double Wall Vents with Type B Double Wall Connectors Serving Two or More Category I Appliances**

Vent Height H (feet)	Common Vent Diameter - D (inches)							
	4 inch		5 inch		6 inch		7 inch	
	Appliance Input Rating in Thousands of Btu per Hour							
	FAN + FAN	FAN + NAT	FAN + FAN	FAN + NAT	FAN + FAN	FAN + NAT	FAN + FAN	FAN + NAT
6	92	81	140	116	204	161	309	248
8	101	90	155	129	224	178	339	275
10	110	97	169	141	243	194	367	299
15	125	112	195	164	283	228	427	352
20	136	123	215	183	314	255	475	394
30	152	138	244	210	361	297	547	459

## Removal of the Furnace from Common Vent

In the event that an existing furnace is removed from a venting system commonly run with separate gas appliances, the venting system is likely to be too large to properly vent the remaining attached appliances.

Conduct the following test while each appliance is operating and the other appliances (which are not operating) remain connected to the common venting system. If the venting system has been installed improperly, you must correct the system as indicated in the general venting requirements section.

### **⚠ WARNING**

#### **CARBON MONOXIDE POISONING HAZARD**

Failure to follow the steps outlined below for each appliance connected to the venting system being placed into operation could result in carbon monoxide poisoning or death.

The following steps shall be followed for each appliance connected to the venting system being placed into operation, while all other appliances connected to the venting system are not in operation:

1. Seal any unused openings in the common venting system.
2. Inspect the venting system for proper size and horizontal pitch. Determine that there is no blockage, restriction, leakage, corrosion, or other deficiencies which could cause an unsafe condition.
3. Close all building doors and windows and all doors between the space in which the appliances remaining connected to the common venting system are located and other spaces of the building. Turn on clothes dryers and any appliances not connected to the common venting system. Turn on any exhaust fans, such as range hoods and bathroom exhausts, so they will operate at maximum speed. Do not operate a summer exhaust fan. Close fireplace dampers.

4. Follow the lighting instructions. Turn on the appliance that is being inspected. Adjust the thermostat so that the appliance operates continuously.
5. After the burners have operated for 5 minutes, test for leaks of flue gases at the draft hood relief opening. Use the flame of a match or candle.
6. After determining that each appliance connected to the common venting system is venting properly, (step 3) return all doors, windows, exhaust fans, fireplace dampers, and any other gas burning appliances to their previous mode of operation.
7. If a venting problem is found during any of the preceding tests, the common venting system must be modified to correct the problem. Resize the common venting system to the minimum vent pipe size determined by using the appropriate tables in Appendix G. (These are in the current standards of the National Fuel Gas Code ANSI Z223.1.

## Gas Piping

### **⚠ CAUTION**

If a flexible gas connector is required or allowed by the authority that has jurisdiction, black iron pipe shall be installed at the gas valve and extend outside the furnace cabinet. The flexible connector can then be added between the black iron pipe and the gas supply line.

### **⚠ WARNING**

Do not over torque (800 in-lbs) or under torque (350 in-lbs) when attaching the gas piping to the gas valve.

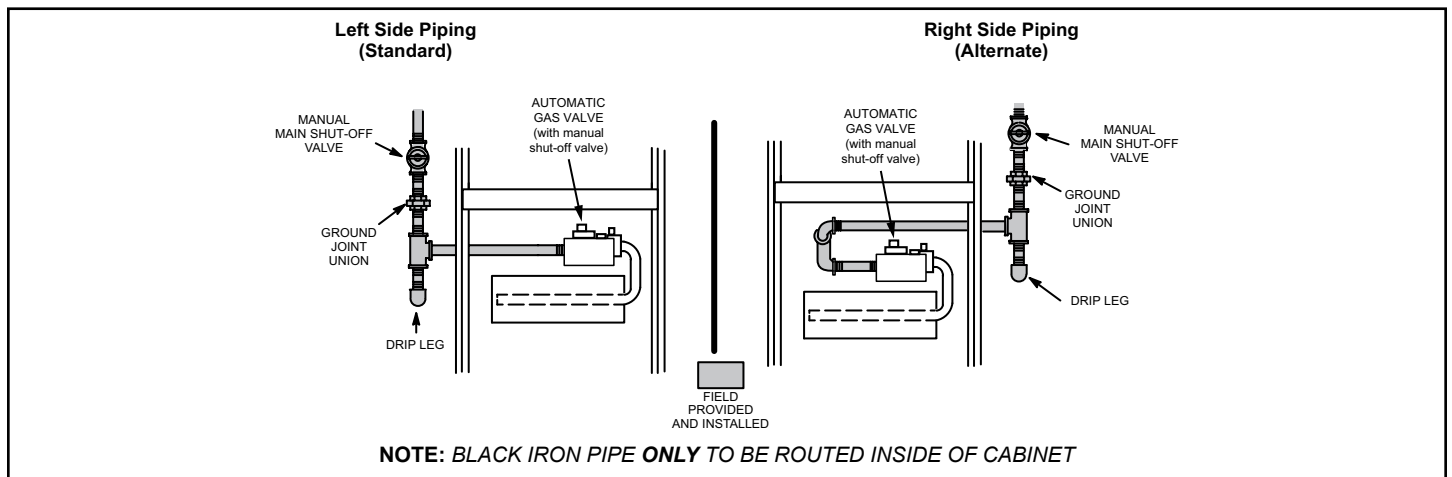

Figure 27. Possible Gas Piping Configurations - Upflow Applications

**Gas Pipe Capacity - FT<sup>3</sup>/HR (kL/HR)**

Nominal Iron Pipe Size - inches (mm)	Internal Diameter - inches (mm)	Length of Pipe - feet (m)									
		10 (3.048)	20 (6.096)	30 (9.144)	40 (12.192)	50 (15.240)	60 (18.288)	70 (21.336)	80 (24.384)	90 (27.432)	100 (30.480)
1/2 (12.7)	.622 (17.799)	172 (4.87)	118 (3.34)	95 (2.69)	81 (2.29)	72 (2.03)	65 (1.84)	60 (1.69)	56 (1.58)	52 (1.47)	50 (1.42)
3/4 (19.05)	.824 (20.930)	360 (10.19)	247 (7.00)	199 (5.63)	170 (4.81)	151 (4.28)	137 (3.87)	126 (3.56)	117 (3.31)	110 (3.11)	104 (2.94)
1 (25.4)	1.049 (26.645)	678 (19.19)	466 (13.19)	374 (10.59)	320 (9.06)	284 (8.04)	257 (7.27)	237 (6.71)	220 (6.23)	207 (5.86)	195 (5.52)
1-1/4 (31.75)	1.380 (35.052)	1350 (38.22)	957 (27.09)	768 (22.25)	657 (18.60)	583 (16.50)	528 (16.50)	488 (13.76)	452 (12.79)	424 (12.00)	400 (11.33)
1-1/2 (38.1)	1.610 (40.894)	2090 (59.18)	1430 (40.49)	1150 (32.56)	985 (27.89)	873 (24.72)	791 (22.39)	728 (20.61)	677 (19.17)	635 (17.98)	600 (17.00)
2 (50.8)	2.067 (52.502)	4020 (113.83)	2760 (78.15)	2200 (62.30)	1900 (53.80)	1680 (47.57)	1520 (43.04)	1400 (39.64)	1300 (36.81)	1220 (34.55)	1160 (32.84)
2-1/2 (63.5)	2.469 (67.713)	6400 (181.22)	4400 (124.59)	3530 (99.95)	3020 (85.51)	2680 (75.88)	2480 (70.22)	2230 (63.14)	2080 (58.89)	1950 (55.22)	1840 (52.10)

**NOTE:** Capacity given in cubic feet of gas per hour (kilo liters of gas per hour) and based on 0.60 specific gravity gas.

**Table 6.**

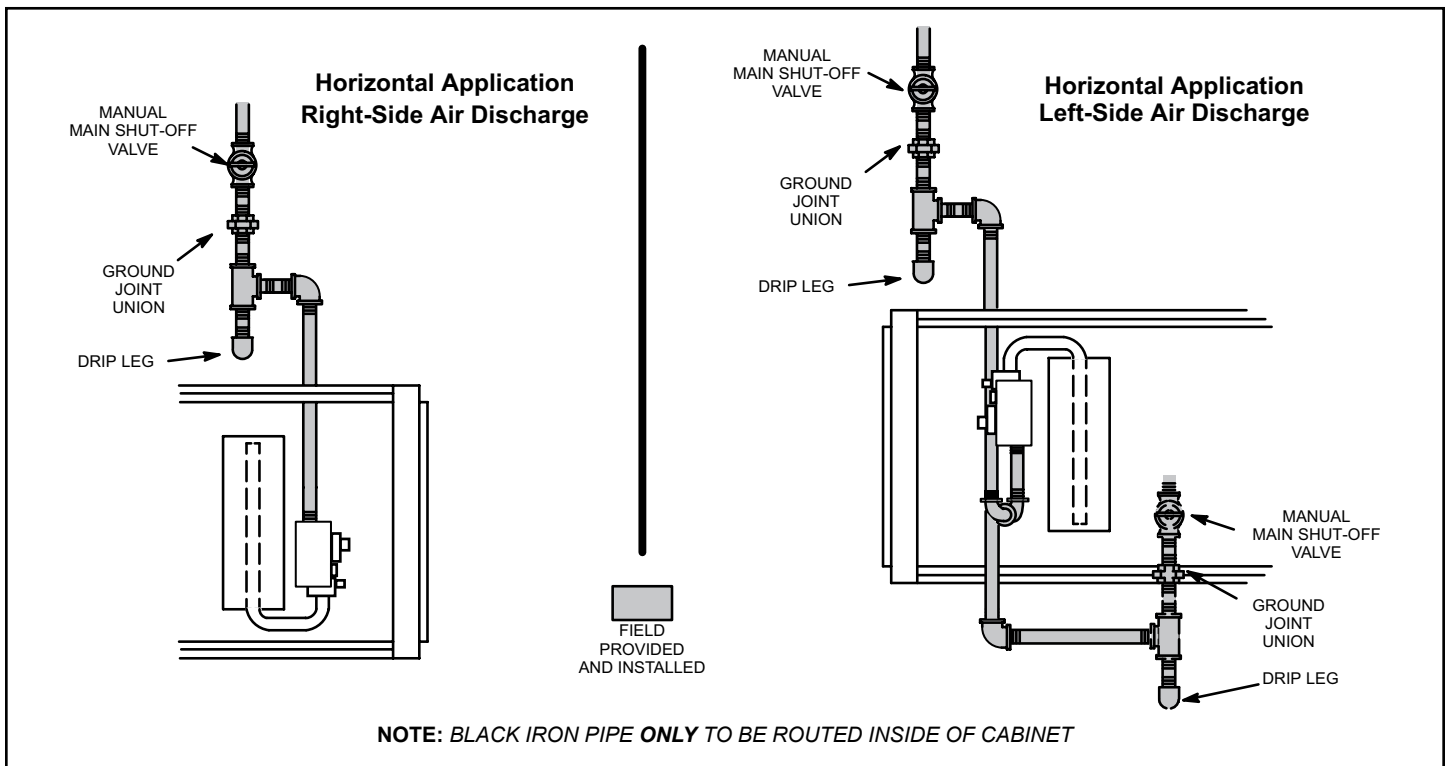

**Figure 28. Possible Gas Piping Configurations - Horizontal Applications**

**Gas Supply**

1. This unit is shipped standard for left or right side installation of gas piping (or top entry in horizontal applications). Connect the gas supply to the piping assembly.
2. When connecting the gas supply piping, consider factors such as length of run, number of fittings, and furnace rating to avoid excessive pressure drop. Table 6 lists recommended pipe sizes for typical applications.
3. The gas piping must not run in or through air ducts, clothes chutes, gas vents or chimneys, dumb waiters, or elevator shafts.

4. The piping should be sloped 1/4 inch (6.4 mm) per 15 feet (4.57 m) upward toward the meter from the furnace. The piping must be supported at proper intervals [every 8 to 10 feet (2.44 to 3.01 m)] with suitable hangers or straps. Install a drip leg in vertical pipe runs to the unit.
5. A 1/8" N.P.T. plugged tap or pressure post is located on the gas valve to facilitate test gauge connection. See Figure 29.
6. In some localities, codes may require the installation of a manual main shut off valve and union (furnished by the installer) external to the unit. The union must be of the ground joint type.

**⚠ IMPORTANT**

Compounds used on threaded joints of gas piping must be resistant to the actions of liquified petroleum gases.

**NOTE:** *If emergency shutoff is necessary, shut off the main manual gas valve and disconnect main power to the furnace. The installer should properly label these devices.*

**Leak Check**

After gas piping is completed, carefully check all field-installed piping connections for gas leaks. Use a commercially available leak detecting solution specifically manufactured for leak detection. Never use an open flame to test for gas leaks.

The furnace must be isolated from the gas supply system by closing the individual manual shut-off valve during any gas supply system at pressures greater than or equal to 1/2 psig (3.48 kPa, 14 inches w.c.). This furnace and its components are designed, manufactured and independently certified to comply with all applicable ANSI/CSA standards. A leak check of the furnace and its components is not required.

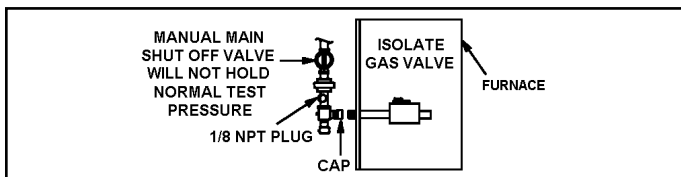

**Figure 29.**

**⚠ IMPORTANT**

When testing pressure of gas lines, gas valve must be disconnected and isolated. See Figure 29. Gas valves can be damaged if subjected to pressures greater than 1/2 psig (3.48 kPa, 14 inches w.c.).

**⚠ WARNING**

**FIRE OR EXPLOSION HAZARD**

Failure to follow the safety warnings exactly could result in serious injury, death, or property damage. Never use an open flame to test for gas leaks. Check all connections using a commercially available soap solution made specifically for leak detection. Some soaps used for leak detection are corrosive to certain metals. Carefully rinse piping thoroughly after leak test has been completed.

**Electrical**

**ELECTROSTATIC DISCHARGE (ESD)**

**Precautions and Procedures**

**⚠ CAUTION**



Electrostatic discharge can affect electronic components. Take precautions to neutralize electrostatic charge by touching your hand and tools to metal prior to handling the control.

**⚠ WARNING**



Electric Shock Hazard. Can cause injury or death. Unit must be properly grounded in accordance with national and local codes.

**⚠ WARNING**

Fire Hazard. Use of aluminum wire with this product may result in a fire, causing property damage, severe injury or death. Use copper wire only with this product.

**⚠ CAUTION**

Failure to use properly sized wiring and circuit breaker may result in property damage. Size wiring and circuit breaker(s) per Technical Specification and unit rating plate.

## **⚠ IMPORTANT**

When matching this gas furnace with zoning, defrost tempering stat or other 24V accessories, it is recommended to replace the factory installed transformer with kit 27J32

Kit 27J32 contains a 75VA transformer, so you do not overload the original 40VA transformer.

The unit is equipped with a field make-up box on the left hand side of the cabinet. The make-up box may be moved to the right side of the furnace to facilitate installation. If the make-up box is moved to the right side, clip the wire ties that bundle the wires together. The excess wire must be pulled into the blower compartment. Secure the excess wire to the existing harness to protect it from damage. Refer to Figure 32 wiring diagram and troubleshooting. The power supply wiring must meet Class I restrictions. Protected by either a fuse or circuit breaker, select circuit protection and wire size according to unit nameplate.

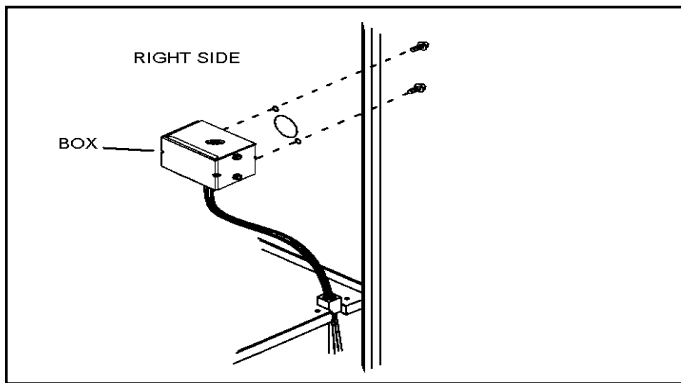

**Figure 30. Interior Make-Up Box Installation (Right side)**

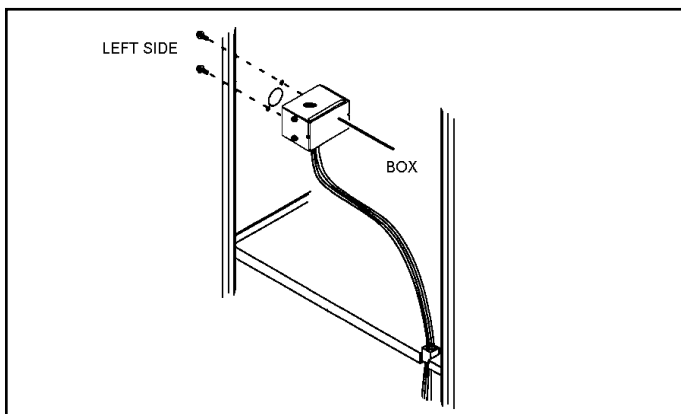

**Figure 31. Interior Make-Up Box Installation (Left Side)**

**NOTE:** Unit nameplate states maximum current draw. Maximum over current protection allowed is 15 AMP.

Holes are on both sides of the furnace cabinet to facilitate wiring.

Install a separate (properly sized) disconnect switch near the furnace so that power can be turned off for servicing.

Before connecting the thermostat, check to make sure the wires will be long enough for servicing at a later date. Make sure that thermostat wire is long enough to facilitate future removal of blower for service.

Complete the wiring connections to the equipment. Use the provided unit wiring diagram shown in Figure 32. Use 18 gauge wire or larger that is suitable for Class II rating for thermostat connections.

Electrically ground the unit according to local codes or, in the absence of local codes, according to the current National Electric Code (ANSI/NFPA No. 70). A green ground wire is provided in the field make-up box.

**NOTE:** This furnace contains electronic components that are polarity sensitive. Make sure that the furnace is wired correctly and is properly grounded.

### **Accessory Terminals**

One line voltage “EAC” 1/4” spade terminal is provided on the furnace integrated control. See Figure 33 for integrated control configuration. This terminal is energized when the indoor blower is operating. Any accessory rated up to one amp can be connected to this terminal with the neutral leg of the circuit being connected to one of the provided neutral terminals. If an accessory rated at greater than one amp is connected to this terminal, it is necessary to use an external relay.

One line voltage “HUM” 1/4” spade terminal is provided on the furnace integrated control. See Figure 33 for integrated control configuration. This terminal is energized in the heating mode when the combustion air inducer is operating. Any humidifier rated up to one amp can be connected to this terminal with the neutral leg of the circuit being connected to one of the provided neutral terminals. If a humidifier rated at greater than one amp is connected to this terminal, it is necessary to use an external relay.

### **Generator Use - Voltage Requirements**

The following requirements must be kept in mind when specifying a generator for use with this equipment:

- The furnace requires 120 volts  $\pm$  10% (Range: 108 volts to 132 volts).
- The furnace operates at 60 Hz  $\pm$  5% (Range: 57 Hz to 63 Hz).
- The furnace integrated control requires both polarity and proper ground. Both polarity and proper grounding should be checked before attempting to operate the furnace on either permanent or temporary power.
- Generator should have a wave form distortion of less than 5% RHO.

# Thermostat

Install the room thermostat according to the instructions provided with the thermostat. See Table 7 for thermostat designations. If the furnace is being matched with a heat pump, refer to the installation instruction or appropriate dual fuel thermostat instructions.

# Indoor Blower Speeds

1. When the thermostat is set to "FAN ON," the indoor blower will run continuously on the low speed when there is no cooling or heating demand. See Table 22 for allowable circulation speeds.
2. When the unit is operating in the high-fire or low-fire heating mode, the indoor blower will run on the corresponding heating speed.
3. When the unit is operating in the low cool or the high cool cooling mode, the indoor blower will run on the corresponding cooling speed.

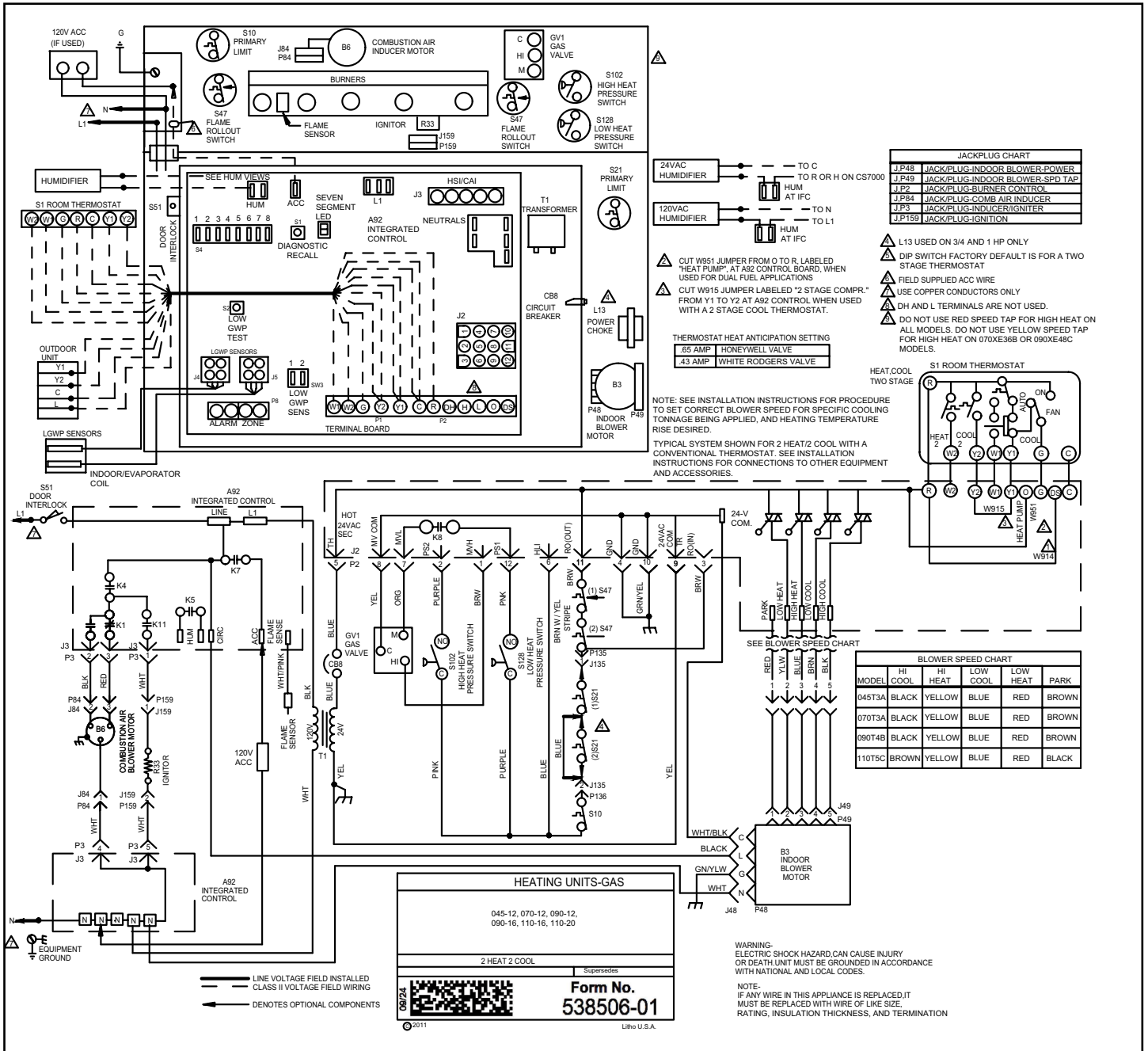
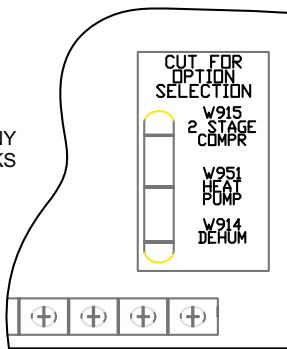
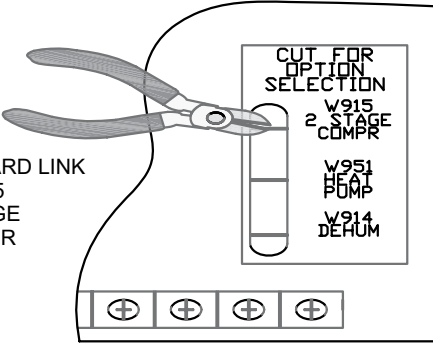
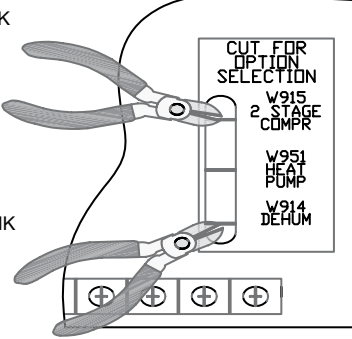

Figure 32. Wiring Diagram

**Table 7. Field Wiring for Non-Communicating Thermostat Applications**

Thermostat	DIP Switch Settings and On-Board Links/Jumper		Wiring Connections																														
	DIP Switch 1	On Board Links Must Be Cut To Select System Options																															
<p><b>1 Heat / 1 Cool</b></p> <p><b>NOTE:</b> Use DIP switch 2 to set second-stage heat ON delay. OFF - 7 minutes ON - 12 minutes</p>	ON	<p>DO NOT CUT ANY ON-BOARD LINKS</p> 	<table border="0"> <tr> <td>T'STAT</td> <td>FURNACE TERM. STRIP</td> <td>OUTDOOR UNIT</td> </tr> <tr> <td></td> <td>(DS)</td> <td></td> </tr> <tr> <td>(W2)</td> <td>(W2)</td> <td></td> </tr> <tr> <td>(W1)-----</td> <td>(W1)</td> <td></td> </tr> <tr> <td>(R)-----</td> <td>(R)</td> <td>*----- (R)</td> </tr> <tr> <td>(G)-----</td> <td>(G)</td> <td></td> </tr> <tr> <td>(C)-----</td> <td>(C)</td> <td>----- (C)</td> </tr> <tr> <td></td> <td>(Y2)</td> <td></td> </tr> <tr> <td>(Y)-----</td> <td>(Y1)</td> <td>----- (Y1)</td> </tr> <tr> <td></td> <td>(O)</td> <td></td> </tr> </table> <p><i>*Not required on all units</i></p>	T'STAT	FURNACE TERM. STRIP	OUTDOOR UNIT		(DS)		(W2)	(W2)		(W1)-----	(W1)		(R)-----	(R)	*----- (R)	(G)-----	(G)		(C)-----	(C)	----- (C)		(Y2)		(Y)-----	(Y1)	----- (Y1)		(O)	
T'STAT	FURNACE TERM. STRIP	OUTDOOR UNIT																															
	(DS)																																
(W2)	(W2)																																
(W1)-----	(W1)																																
(R)-----	(R)	*----- (R)																															
(G)-----	(G)																																
(C)-----	(C)	----- (C)																															
	(Y2)																																
(Y)-----	(Y1)	----- (Y1)																															
	(O)																																
<p><b>1 Heat / 2 Cool</b></p> <p><b>NOTE:</b> Use DIP switch 2 to set second-stage heat ON delay. OFF - 7 minutes ON - 12 minutes</p>	ON	<p>CUT ON-BOARD LINK W915 2 STAGE COMPR</p> 	<table border="0"> <tr> <td>T'STAT</td> <td>FURNACE TERM. STRIP</td> <td>OUTDOOR UNIT</td> </tr> <tr> <td></td> <td>(DS)</td> <td></td> </tr> <tr> <td></td> <td>(W2)</td> <td></td> </tr> <tr> <td>(W)-----</td> <td>(W1)</td> <td></td> </tr> <tr> <td>(R)-----</td> <td>(R)</td> <td>*----- (R)</td> </tr> <tr> <td>(G)-----</td> <td>(G)</td> <td></td> </tr> <tr> <td>(C)-----</td> <td>(C)</td> <td>----- (C)</td> </tr> <tr> <td>(Y2)-----</td> <td>(Y2)</td> <td>----- (Y2)</td> </tr> <tr> <td>(Y1)-----</td> <td>(Y1)</td> <td>----- (Y1)</td> </tr> <tr> <td></td> <td>(O)</td> <td></td> </tr> </table> <p><i>*Not required on all units</i></p>	T'STAT	FURNACE TERM. STRIP	OUTDOOR UNIT		(DS)			(W2)		(W)-----	(W1)		(R)-----	(R)	*----- (R)	(G)-----	(G)		(C)-----	(C)	----- (C)	(Y2)-----	(Y2)	----- (Y2)	(Y1)-----	(Y1)	----- (Y1)		(O)	
T'STAT	FURNACE TERM. STRIP	OUTDOOR UNIT																															
	(DS)																																
	(W2)																																
(W)-----	(W1)																																
(R)-----	(R)	*----- (R)																															
(G)-----	(G)																																
(C)-----	(C)	----- (C)																															
(Y2)-----	(Y2)	----- (Y2)																															
(Y1)-----	(Y1)	----- (Y1)																															
	(O)																																
<p><b>1 Heat / 2 Cool with t'stat with dehumidification mode</b></p> <p><b>NOTE:</b> Use DIP switch 2 to set second-stage heat ON delay. OFF - 7 minutes ON - 12 minutes</p>	ON	<p>CUT ON-BOARD LINK W915 2 STAGE COMPR</p> <p>CUT ON-BOARD LINK W914 DEHUM</p> 	<table border="0"> <tr> <td>T'STAT</td> <td>FURNACE TERM. STRIP</td> <td>OUTDOOR UNIT</td> </tr> <tr> <td>(DS)-----</td> <td>(DS)</td> <td></td> </tr> <tr> <td></td> <td>(W2)</td> <td></td> </tr> <tr> <td>(W1)-----</td> <td>(W1)</td> <td></td> </tr> <tr> <td>(R)-----</td> <td>(R)</td> <td>*----- (R)</td> </tr> <tr> <td>(G)-----</td> <td>(G)</td> <td></td> </tr> <tr> <td>(C)-----</td> <td>(C)</td> <td>----- (C)</td> </tr> <tr> <td>(Y2)-----</td> <td>(Y2)</td> <td>----- (Y2)</td> </tr> <tr> <td>(Y1)-----</td> <td>(Y1)</td> <td>----- (Y1)</td> </tr> <tr> <td></td> <td>(O)</td> <td></td> </tr> </table> <p><i>*Not required on all units</i></p>	T'STAT	FURNACE TERM. STRIP	OUTDOOR UNIT	(DS)-----	(DS)			(W2)		(W1)-----	(W1)		(R)-----	(R)	*----- (R)	(G)-----	(G)		(C)-----	(C)	----- (C)	(Y2)-----	(Y2)	----- (Y2)	(Y1)-----	(Y1)	----- (Y1)		(O)	
T'STAT	FURNACE TERM. STRIP	OUTDOOR UNIT																															
(DS)-----	(DS)																																
	(W2)																																
(W1)-----	(W1)																																
(R)-----	(R)	*----- (R)																															
(G)-----	(G)																																
(C)-----	(C)	----- (C)																															
(Y2)-----	(Y2)	----- (Y2)																															
(Y1)-----	(Y1)	----- (Y1)																															
	(O)																																

NOTE - Do NOT make a wire connection between the room thermostat L terminal and the L terminal of the integrated control.

**Table 7. Field Wiring for Non-Communicating Thermostat Applications**

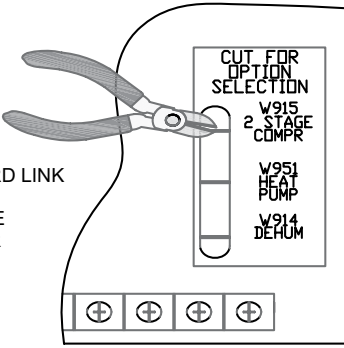
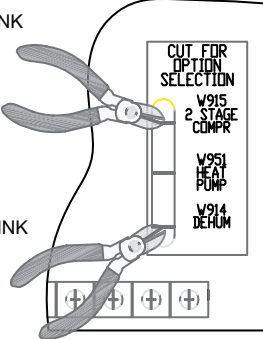
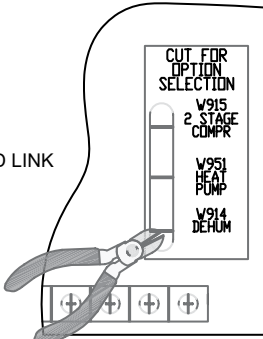
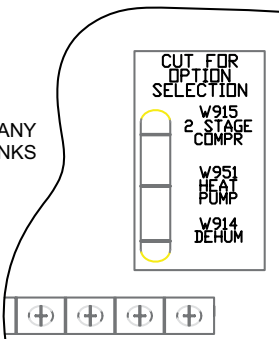
Thermostat	DIP Switch Settings and On-Board Links/Jumper		Wiring Connections																														
	DIP Switch 1	On Board Links Must Be Cut To Select System Options																															
2 Heat / 2 Cool	OFF	<p>CUT ON-BOARD LINK W915 2 STAGE COMPR</p> 	<table border="0"> <thead> <tr> <th>T'STAT</th> <th>FURNACE TERM. STRIP</th> <th>OUTDOOR UNIT</th> </tr> </thead> <tbody> <tr> <td></td> <td>(DS)</td> <td></td> </tr> <tr> <td>(W2)-----</td> <td>(W2)</td> <td></td> </tr> <tr> <td>(W1)-----</td> <td>(W1)</td> <td></td> </tr> <tr> <td>(R)-----</td> <td>(R)-----*</td> <td>(R)</td> </tr> <tr> <td>(G)-----</td> <td>(G)</td> <td></td> </tr> <tr> <td>(C)-----</td> <td>(C)-----</td> <td>(C)</td> </tr> <tr> <td>(Y2)-----</td> <td>(Y2)-----</td> <td>(Y2)</td> </tr> <tr> <td>(Y1)-----</td> <td>(Y1)-----</td> <td>(Y1)</td> </tr> <tr> <td></td> <td></td> <td>(O) *Not required on all units</td> </tr> </tbody> </table>	T'STAT	FURNACE TERM. STRIP	OUTDOOR UNIT		(DS)		(W2)-----	(W2)		(W1)-----	(W1)		(R)-----	(R)-----*	(R)	(G)-----	(G)		(C)-----	(C)-----	(C)	(Y2)-----	(Y2)-----	(Y2)	(Y1)-----	(Y1)-----	(Y1)			(O) *Not required on all units
T'STAT	FURNACE TERM. STRIP	OUTDOOR UNIT																															
	(DS)																																
(W2)-----	(W2)																																
(W1)-----	(W1)																																
(R)-----	(R)-----*	(R)																															
(G)-----	(G)																																
(C)-----	(C)-----	(C)																															
(Y2)-----	(Y2)-----	(Y2)																															
(Y1)-----	(Y1)-----	(Y1)																															
		(O) *Not required on all units																															
2 Heat / 2 Cool with t'stat with dehumidification mode	OFF	<p>CUT ON-BOARD LINK W915 2 STAGE COMPR</p> <p>CUT ON-BOARD LINK W914</p> 	<table border="0"> <thead> <tr> <th>T'STAT</th> <th>FURNACE TERM. STRIP</th> <th>OUTDOOR UNIT</th> </tr> </thead> <tbody> <tr> <td>(DS)-----</td> <td>(DS)</td> <td></td> </tr> <tr> <td>(W2)-----</td> <td>(W2)</td> <td></td> </tr> <tr> <td>(W1)-----</td> <td>(W1)</td> <td></td> </tr> <tr> <td>(R)-----</td> <td>(R)-----*</td> <td>(R)</td> </tr> <tr> <td>(G)-----</td> <td>(G)</td> <td></td> </tr> <tr> <td>(C)-----</td> <td>(C)-----</td> <td>(C)</td> </tr> <tr> <td>(Y2)-----</td> <td>(Y2)-----</td> <td>(Y2)</td> </tr> <tr> <td>(Y1)-----</td> <td>(Y1)-----</td> <td>(Y1)</td> </tr> <tr> <td></td> <td></td> <td>(O) *Not required on all units</td> </tr> </tbody> </table>	T'STAT	FURNACE TERM. STRIP	OUTDOOR UNIT	(DS)-----	(DS)		(W2)-----	(W2)		(W1)-----	(W1)		(R)-----	(R)-----*	(R)	(G)-----	(G)		(C)-----	(C)-----	(C)	(Y2)-----	(Y2)-----	(Y2)	(Y1)-----	(Y1)-----	(Y1)			(O) *Not required on all units
T'STAT	FURNACE TERM. STRIP	OUTDOOR UNIT																															
(DS)-----	(DS)																																
(W2)-----	(W2)																																
(W1)-----	(W1)																																
(R)-----	(R)-----*	(R)																															
(G)-----	(G)																																
(C)-----	(C)-----	(C)																															
(Y2)-----	(Y2)-----	(Y2)																															
(Y1)-----	(Y1)-----	(Y1)																															
		(O) *Not required on all units																															
2 Heat / 1 Cool with t'stat with dehumidification mode	OFF	<p>CUT ON-BOARD LINK W914</p> 	<table border="0"> <thead> <tr> <th>T'STAT</th> <th>FURNACE TERM. STRIP</th> <th>OUTDOOR UNIT</th> </tr> </thead> <tbody> <tr> <td>(DS)-----</td> <td>(DS)</td> <td></td> </tr> <tr> <td>(W2)-----</td> <td>(W2)</td> <td></td> </tr> <tr> <td>(W1)-----</td> <td>(W1)</td> <td></td> </tr> <tr> <td>(R)-----</td> <td>(R)-----*</td> <td>(R)</td> </tr> <tr> <td>(G)-----</td> <td>(G)</td> <td></td> </tr> <tr> <td>(C)-----</td> <td>(C)-----</td> <td>(C)</td> </tr> <tr> <td>(Y1)-----</td> <td>(Y1)-----</td> <td>(Y1)</td> </tr> <tr> <td></td> <td></td> <td>(O) *Not required on all units</td> </tr> </tbody> </table>	T'STAT	FURNACE TERM. STRIP	OUTDOOR UNIT	(DS)-----	(DS)		(W2)-----	(W2)		(W1)-----	(W1)		(R)-----	(R)-----*	(R)	(G)-----	(G)		(C)-----	(C)-----	(C)	(Y1)-----	(Y1)-----	(Y1)			(O) *Not required on all units			
T'STAT	FURNACE TERM. STRIP	OUTDOOR UNIT																															
(DS)-----	(DS)																																
(W2)-----	(W2)																																
(W1)-----	(W1)																																
(R)-----	(R)-----*	(R)																															
(G)-----	(G)																																
(C)-----	(C)-----	(C)																															
(Y1)-----	(Y1)-----	(Y1)																															
		(O) *Not required on all units																															
2 Heat / 1 Cool	OFF	<p>DO NOT CUT ANY ON-BOARD LINKS</p> 	<table border="0"> <thead> <tr> <th>T'STAT</th> <th>FURNACE TERM. STRIP</th> <th>OUTDOOR UNIT</th> </tr> </thead> <tbody> <tr> <td></td> <td>(DS)</td> <td></td> </tr> <tr> <td>(W2)-----</td> <td>(W2)</td> <td></td> </tr> <tr> <td>(W1)-----</td> <td>(W1)</td> <td></td> </tr> <tr> <td>(R)-----</td> <td>(R)-----*</td> <td>(R)</td> </tr> <tr> <td>(G)-----</td> <td>(G)</td> <td></td> </tr> <tr> <td>(C)-----</td> <td>(C)-----</td> <td>(C)</td> </tr> <tr> <td></td> <td>(Y2)</td> <td></td> </tr> <tr> <td>(Y)-----</td> <td>(Y1)-----</td> <td>(Y1)</td> </tr> <tr> <td></td> <td></td> <td>(O) *Not required on all units</td> </tr> </tbody> </table>	T'STAT	FURNACE TERM. STRIP	OUTDOOR UNIT		(DS)		(W2)-----	(W2)		(W1)-----	(W1)		(R)-----	(R)-----*	(R)	(G)-----	(G)		(C)-----	(C)-----	(C)		(Y2)		(Y)-----	(Y1)-----	(Y1)			(O) *Not required on all units
T'STAT	FURNACE TERM. STRIP	OUTDOOR UNIT																															
	(DS)																																
(W2)-----	(W2)																																
(W1)-----	(W1)																																
(R)-----	(R)-----*	(R)																															
(G)-----	(G)																																
(C)-----	(C)-----	(C)																															
	(Y2)																																
(Y)-----	(Y1)-----	(Y1)																															
		(O) *Not required on all units																															

NOTE - Do NOT make a wire connection between the room thermostat L terminal and the L terminal of the integrated control.

**Table 7. Field Wiring for Non-Communicating Thermostat Applications**

Thermostat	DIP Switch Settings and On-Board Links/Jumper		Wiring Connections
	DIP Switch 1	On Board Links Must Be Cut To Select System Options	
<b>Dual Fuel Single-Stage Heat Pump Thermostat w/dual fuel capabilities</b> <b>Capable of 2-stage gas heat control</b>	OFF	<p>CUT ON-BOARD LINK W951 HEAT PUMP</p>	
<b>Dual Fuel Two-Stage Heat Pump Thermostat w/dual fuel capabilities</b> <b>Capable of 2-stage gas heat control</b>	OFF	<p>CUT ON-BOARD LINK W915 2 STAGE COMPR</p> <p>CUT ON-BOARD LINK W951 HEAT PUMP</p>	

NOTE - Do NOT make a wire connection between the room thermostat L terminal and the L terminal of the integrated control.

**Table 7. Field Wiring for Non-Communicating Thermostat Applications**

Thermostat	DIP Switch Settings and On-Board Links/Jumper		Wiring Connections																																													
	DIP Switch 1	On Board Links Must Be Cut To Select System Options																																														
<b>Dual Fuel Single-Stage Heat Pump</b> Thermostat w/dual fuel capabilities Capable of 2-stage gas heat control with dehumidification mode	OFF	CUT ON-BOARD LINK W951 HEAT PUMP  CUT ON-BOARD LINK W914 DEHUM	<table border="0"> <tr> <td>T'STAT</td> <td>FURNACE TERM. STRIP</td> <td>HEAT PUMP</td> </tr> <tr> <td>(R) ---</td> <td>(R) ---</td> <td>(R)</td> </tr> <tr> <td>(H) ---</td> <td></td> <td></td> </tr> <tr> <td>(W2) ---</td> <td>(W2) ---</td> <td></td> </tr> <tr> <td>(W1) ---</td> <td>(W1) ---</td> <td>(W1) ---</td> </tr> <tr> <td>(O) ---</td> <td>(O) ---</td> <td>(O)</td> </tr> <tr> <td>(L) ---</td> <td></td> <td>(L)</td> </tr> <tr> <td>(Y1) ---</td> <td>(Y1) ---</td> <td>(Y)</td> </tr> <tr> <td>(Y2) ---</td> <td></td> <td></td> </tr> <tr> <td>(G) ---</td> <td>(G) ---</td> <td></td> </tr> <tr> <td>(D) ---</td> <td>(DS) ---</td> <td></td> </tr> <tr> <td>(B) ---</td> <td>(Y2) ---</td> <td></td> </tr> <tr> <td>(C) ---</td> <td>(C) ---</td> <td>(C)</td> </tr> <tr> <td>(T) ---</td> <td></td> <td>outdoor sensor</td> </tr> <tr> <td>(T) ---</td> <td></td> <td></td> </tr> </table>	T'STAT	FURNACE TERM. STRIP	HEAT PUMP	(R) ---	(R) ---	(R)	(H) ---			(W2) ---	(W2) ---		(W1) ---	(W1) ---	(W1) ---	(O) ---	(O) ---	(O)	(L) ---		(L)	(Y1) ---	(Y1) ---	(Y)	(Y2) ---			(G) ---	(G) ---		(D) ---	(DS) ---		(B) ---	(Y2) ---		(C) ---	(C) ---	(C)	(T) ---		outdoor sensor	(T) ---		
T'STAT	FURNACE TERM. STRIP	HEAT PUMP																																														
(R) ---	(R) ---	(R)																																														
(H) ---																																																
(W2) ---	(W2) ---																																															
(W1) ---	(W1) ---	(W1) ---																																														
(O) ---	(O) ---	(O)																																														
(L) ---		(L)																																														
(Y1) ---	(Y1) ---	(Y)																																														
(Y2) ---																																																
(G) ---	(G) ---																																															
(D) ---	(DS) ---																																															
(B) ---	(Y2) ---																																															
(C) ---	(C) ---	(C)																																														
(T) ---		outdoor sensor																																														
(T) ---																																																
<b>Dual Fuel Two-Stage Heat Pump</b> Thermostat w/dual fuel capabilities Capable of 2-stage gas heat control with dehumidification mode	OFF	CUT ON-BOARD LINK W915 2 STAGE COMPR  CUT ON-BOARD LINK W951 HEAT PUMP  CUT ON-BOARD LINK W914 DEHUM	<table border="0"> <tr> <td>T'STAT</td> <td>FURNACE TERM. STRIP</td> <td>HEAT PUMP</td> </tr> <tr> <td>(R) ---</td> <td>(R) ---</td> <td>(R)</td> </tr> <tr> <td>(H) ---</td> <td></td> <td></td> </tr> <tr> <td>(W2) ---</td> <td>(W2) ---</td> <td></td> </tr> <tr> <td>(W1) ---</td> <td>(W1) ---</td> <td>(W1) ---</td> </tr> <tr> <td>(O) ---</td> <td>(O) ---</td> <td>(O)</td> </tr> <tr> <td>(L) ---</td> <td></td> <td>(L)</td> </tr> <tr> <td>(Y1) ---</td> <td>(Y1) ---</td> <td>(Y1)</td> </tr> <tr> <td>(Y2) ---</td> <td></td> <td>(Y2)</td> </tr> <tr> <td>(G) ---</td> <td>(G) ---</td> <td></td> </tr> <tr> <td>(D) ---</td> <td>(DS) ---</td> <td></td> </tr> <tr> <td>(B) ---</td> <td>(Y2) ---</td> <td>Y2 out blue</td> </tr> <tr> <td>(C) ---</td> <td>(C) ---</td> <td>(C)</td> </tr> <tr> <td>(T) ---</td> <td></td> <td>outdoor sensor</td> </tr> <tr> <td>(T) ---</td> <td></td> <td></td> </tr> </table>	T'STAT	FURNACE TERM. STRIP	HEAT PUMP	(R) ---	(R) ---	(R)	(H) ---			(W2) ---	(W2) ---		(W1) ---	(W1) ---	(W1) ---	(O) ---	(O) ---	(O)	(L) ---		(L)	(Y1) ---	(Y1) ---	(Y1)	(Y2) ---		(Y2)	(G) ---	(G) ---		(D) ---	(DS) ---		(B) ---	(Y2) ---	Y2 out blue	(C) ---	(C) ---	(C)	(T) ---		outdoor sensor	(T) ---		
T'STAT	FURNACE TERM. STRIP	HEAT PUMP																																														
(R) ---	(R) ---	(R)																																														
(H) ---																																																
(W2) ---	(W2) ---																																															
(W1) ---	(W1) ---	(W1) ---																																														
(O) ---	(O) ---	(O)																																														
(L) ---		(L)																																														
(Y1) ---	(Y1) ---	(Y1)																																														
(Y2) ---		(Y2)																																														
(G) ---	(G) ---																																															
(D) ---	(DS) ---																																															
(B) ---	(Y2) ---	Y2 out blue																																														
(C) ---	(C) ---	(C)																																														
(T) ---		outdoor sensor																																														
(T) ---																																																

NOTE - Do NOT make a wire connection between the room thermostat L terminal and the L terminal of the integrated control.

**TWO STAGE CONSTANT TORQUE, NON-COMMUNICATING  
107897-XX**

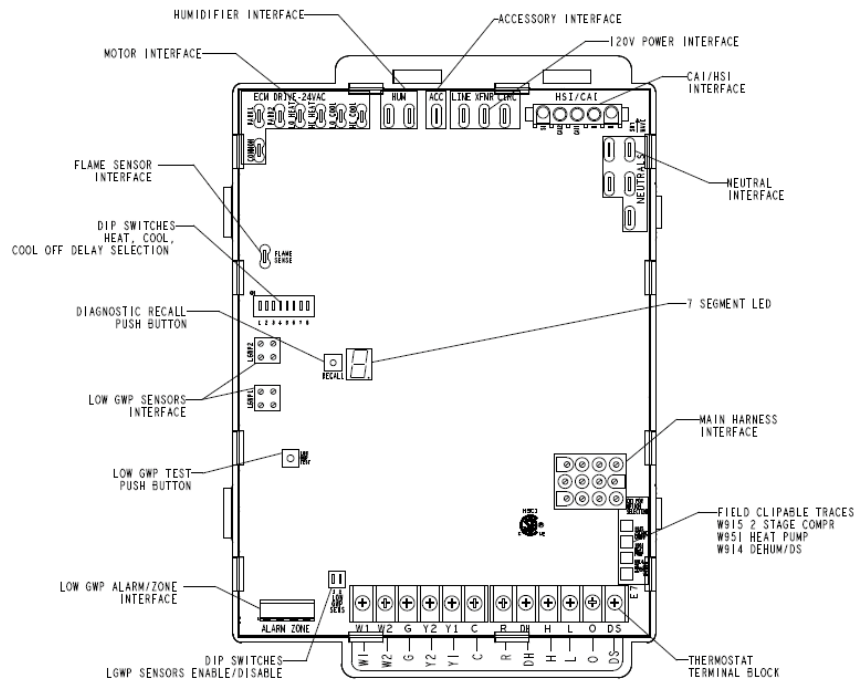

**Figure 33.**

**Table 8.**

1/4" QUICK CONNECT TERMINALS	
120V HUM	POWER FOR HUMIDIFIER (120 VAC)
LINE	INCOMING POWER LINE (120 VAC)
XFMR	TRANSFORMER PRIMARY (120 VAC)
CIRC	INDOOR BLOWER MOTOR (120 VAC)
ACC	ACCESSORY(120 VAC)
24V HUM	HUMIDIFIER (24 VAC)
NEUTRALS	NEUTRAL (5)
3/16" QUICK CONNECT TERMINALS	
LO COOL	COOL SPEED TAP FROM INDOOR BLOWER MOTOR (24 VAC)
HI COOL	COOL SPEED TAP FROM INDOOR BLOWER MOTOR (24 VAC)
LO HEAT	HEAT SPEED TAP FROM INDOOR BLOWER MOTOR (24 VAC)
HI HEAT	HEAT SPEED TAP FROM INDOOR BLOWER MOTOR (24 VAC)
FAN	CONTINUOUS FAN SPEED TAP FROM INDOOR BLOWER MOTOR (24 VAC)
FLAME SENSE	FLAME SENSOR ELECTRODE (120 VAC)
COMMON	COMMON (24 VAC)
PARK	3 TERMINALS TO PARK UNUSED MOTOR SPEED TAPS

**Table 9.**

THERMOSTAT INPUT TERMINALS	
W1	LOW STAGE HEAT
W2	HIGH STAGE HEAT
G	FAN
Y1	LOW STAGE COOL (when W915 is clipped)
Y2	HIGH STAGE COOL (when W915 is clipped)
C	THERMOSTAT COMMON / GROUND
R	24VAC TO THE THERMOSTAT
H	24VAC HUMIDIFER OUTPUT (Unused)
L	LSOM (Unused)
O	HEAT PUMP REVERSING VALVE (when W951 is clipped)
DH	DEHUMIDIFICATION (Unused)
DS	DEHUMIDIFICATION

**Table 10.**

LOW GWP INTERFACE	
LGWP1	LOW GWP SENSOR #1 INTERFACE
LGWP2	LOW GWP SENSOR # 2 INTERFACE
ALARM	INTERFACE TO LOW GWP LEAK AUDIBLE ALARM (DRY CONTACT)
ZONE	INTERFACE TO LOW GWP LEAK AUDIBLE ALARM (DRY CONTACT)
LGWP TEST	PUSH BUTTON TO TEST LOW GWP FUNCTIONALITY

## Ignition Control Diagnostic Codes

<b>DIAGNOSTIC CODES / STATUS OF FURNACE</b>	<b>CODE</b>
IDLE MODE (DECIMAL BLINKS AT 1 HERTZ -- 0.5 SECONDS ON, 0.5 SECONDS OFF)	.
INDOOR BLOWER OPERATION: CONTINUOUS FAN MODE (CONSTANT TORQUE ONLY)	A
INDOOR BLOWER OPERATION: FOLLOWED BY CFM SETTING FOR INDOOR BLOWER (1 SECOND ON, 0.5 SECOND OFF) / CFM SETTING FOR MODE DISPLAYED (VARIABLE SPEED ONLY)	A
COOLING STAGE (1 SECOND ON, 0.5 SECOND OFF) 1 OR 2 DISPLAYED / PAUSE / REPEAT CODES. VARIABLE SPEED ONLY	C
GAS HEAT (1 SECOND ON, 0.5 SECOND OFF) PAUSE / CFM DISPLAYED / PAUSE / REPEAT CODES BLINKING - IGNITION	H
HEAT PUMP STAGE (1 SECOND ON, 0.5 SECOND OFF) 1 OR 2 DISPLAYED / PAUSE / CFM SETTING DISPLAYED / PAUSE / REPEAT CODES	h
DEFROST MODE	dF
<b>ERROR/FAULT CONDITION</b>	<b>CODE</b>
NO ERROR IN THE MEMORY	E000
<b>ELECTRICAL FAULTS (WAIT FOR RECOVERY)</b>	
AC LINE VOLTAGE LOW	E110
TWIN COMMUNICATION FAULT (CONSTANT TORQUE ONLY)	E106
LINE VOLTAGE POLARITY REVERSED	E111
EARTH GROUND NOT DETECTED	E112
AC LINE VOLTAGE HIGH	E113
LINE VOLTAGE FREQUENCY OUT OF RANGE	E114
LOW 24V - CONTROL WILL RESTART IF THE ERROR RECOVERS	E115
<b>HARDWARE FAULT (5 MINUTES LOCKOUT)</b>	
CONTROL HARDWARE (INCLUDE A/D ELECTRONICS AND FLAME TEST) FAILURE	E125
<b>HARD LOCKOUT FAULT</b>	
ROLLOUT OPEN OR PREVIOUSLY OPENED	E200
<b>GAS VALVE/PRESSURE SWITCH/LIMIT FAULTS (wait for recovery)</b>	
GAS VALVE RELAY (1ST OR 2ND STAGE) PROBLEM	E204
LOW PRESSURE SW FAILED TO CLOSE (STUCK OPEN)	E223
LOW PRESSURE SW FAILED TO OPEN (STUCK CLOSED)	E224
HIGH PRESSURE SW FAILED TO CLOSE (STUCK OPEN)	E225
HIGH PRESSURE SW FAILED TO OPEN (STUCK CLOSED)	E226
LOW PRESSURE SWITCH OPENED IN RUN OR TFI	E227
FLAME SENSE OUT OF SEQUENCE-STILL PRESENT	E241
PRIMARY LIMIT SWITCH OPENED	E250
<b>SOFT LOCKOUT FAULTS (60 MINUTES)</b>	
GAS VALVE RELAY (1ST OR 2ND STAGE) CONTACT SHORTED	E205
HOT SURFACE IGNITOR (HSI) SENSED OPEN	E207
SOFT LOCKOUT-FLAME FAILURE ON IGNITION, IGNITION RETRY>MAX, LAST FAILED RETRY DUE TO FLAME FAILURE	E270
SOFT LOCKOUT-PRESSURE SWITCH OPEN, IGNITION RETRY>MAX, LAST FAILED RETRY DUE TO LPSW OPEN	E271
SOFT LOCKOUT-PRESSURE SWITCH OPEN, IN RUN MODE HEATING RECYCLES>MAX, LAST FAILED RETRY DUE TO LPSW OPEN	E272
SOFT LOCKOUT-FLAME FAILURE IN RUN MODE, HEATING RECYCLES>MAX, LAST FAILED RETRY DUE TO LOSS OF FLAME	E273
SOFT LOCKOUT-LIMIT OPEN > 3 MINUTES	E274
SOFT LOCKOUT-FLAME OUT OF SEQUENCE AND IS GONE	E275
IGNITOR CIRCUIT FAULT-FAILED IGNITOR OR TRIGGERING CIRCUITRY.	E290

**IGNITION CONTROL DIAGNOSTIC CODES (CONTINUED)**

<b>PERFORMANCE WARNING</b>	
POOR GROUND DETECTED	E117
IGNITION ON HIGH FIRE	E229
LOW FLAME CURRENT IN HEATING MODE	E240
<b>LOW GWP REFRIGERANT FAULTS</b>	
REFRIGERANT LEAK DETECTED, THERMOSTAT LOCKOUT	E150
REFRIGERANT LEAK DETECTOR SENSOR #1 FAULT	E151
REFRIGERANT LEAK DETECTOR SENSOR #2 FAULT	E152
REFRIGERANT LEAK DETECTOR SENSOR #1 COMM. LOST	E154
REFRIGERANT LEAK DETECTOR SENSOR #2 COMM. LOST	E155
REFRIGERANT LEAK DETECTOR SENSOR #1 TYPE INCORRECT	E160
REFRIGERANT LEAK DETECTOR SENSOR #2 TYPE INCORRECT	E161
REFRIGERANT LEAK DETECTOR CONTROL FAILURE	E163
LOW GWP TEST	E164
LOW GWP RELAY STUCK	E390

**Low GWP Application**

**⚠ WARNING**

For use with Allied approved evaporator coil and LGWP sensors only. Use original manufacturer recommended LGWP sensors if using Allied approved evaporator coil.

**CONNECTING THE FURNACE CONTROL BOARD SENSOR.**

See Figure 36 and follow steps below:

- 1 - Route sensor wire #1 through provided grommet. Form a drip loop below the control board on upflow installations to prevent condensate dripping on the control board.
- 2 - Avoid sharp edges when routing sensor wire during installation.
- 3 - Sensor wire must not block view of 7 segment LED .

Ensure the cable is properly seated into the SENSOR 1 plug (LGWP1). The Molex plug clip should lock into the Molex connection point for a secured connection, as shown below in Figure 34. Verify the connection is free of dust, debris, and moisture.

**NOTE** - In confined space applications, connect the second sensor to the SENSOR 2 plug (LGWP2). Refer to evaporator coil installation instructions for more detail.

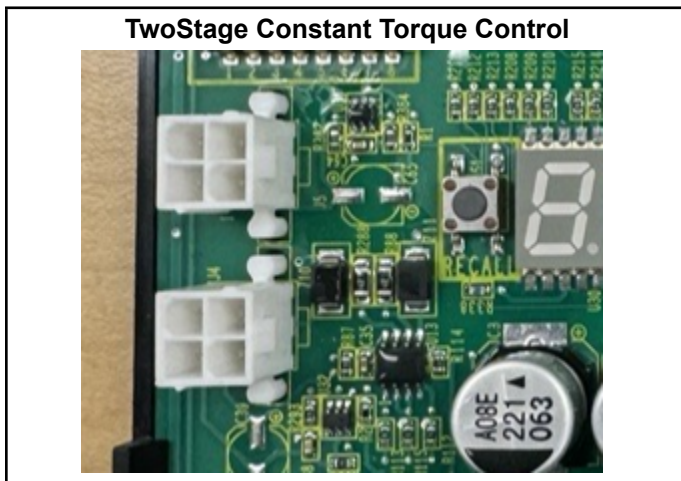

**Figure 34.**

**LOW GWP DIP SWITCH SETTINGS**

Adjust the DIP switch settings to the sensor configuration. Failure to do so will cause faults on power-up. See Figure 35 and Table 11.



**Figure 35.**

**Table 11.**  
DIP Switch Settings

Configuration	Switch 1	Switch 2
One (1) sensor, connected to SENSOR 1 plug	OFF (enable)	ON (disable)
Two (2) sensors, connected to SENSOR 1 plug and SENSOR 2 plug	OFF (enable)	OFF (enable)

In single sensor configurations, the sensor must be connected to the SENSOR 1 plug (LGWP1). Configurations other than the ones shown in Table 11 will cause a servicing fault.

Each DIP switch corresponds to a sensor position (i.e., DIP switch 1 to sensor 1; DIP switch 2 to sensor 2). The default factory switch positions are set to OFF (ENABLED)

The furnace control board software reads the OFF position as an active sensor. A sensor should be present for the corresponding sensor connector. Setting the DIP switch to ON disables the sensor position.

**SECONDARY SENSOR REQUIREMENTS**

**Additional Line Sets**

If additional refrigerant line joints are present outside of the line set sleeve and a secondary refrigerant detection sensor is required, its installation must comply with the requirements listed in Refrigerant Detection Sensor Kit (27V53). See Figure 36 for routing the secondary sensor cable through the furnace cabinet.

**Non-Low GWP Applications**

**⚠ IMPORTANT**

For Furnace only applications or Furnace replacement in a Non-Low GWP applications, the Low GWP sensors should be disabled, otherwise the blower will operate continuously. To do this, the Low GWP DIP switches setting for both – Sensor 1 and the Sensor 2 must be moved to the ON position.

## FURNACE CONTROL BOARD LOW GWP MODES OF OPERATION

The modes of operation for the furnace control board are Initializing, Normal, Leak Detected, and Fault.

### Initializing

The furnace control board is establishing connection with the refrigerant detection sensor and is completing an initial five-minute purge sequence.

### Normal

The HVAC system is functioning normally. The furnace control board has not detected a refrigerant leak.

### Leak Detected

When the furnace control board detects a refrigerant leak:

1. The furnace control board shuts off the (R) input (24VAC power) to the thermostat, which de-energizes the outdoor unit compressor and heat sources, such as gas and/or electric strip heat. No heating or cooling demands will be made.

2. The furnace control board activates the blower (high speed). The blower purges refrigerant from the cabinet, plenum, and ductwork.
3. After the furnace control board determines the refrigerant levels are below the safety threshold, the blower will continue to operate for the remainder of the seven (7) -minute cycle.
4. After the blower sequence is complete, the HVAC system resumes normal operation.

**NOTE** - The HVAC system may not maintain a cooling or heating setpoint if a significant leak exists. Any refrigerant leaks that remain unaddressed for an extended time may cause the HVAC system to shut down on a low refrigerant pressure limit condition.

### Fault

When a Low GWP fault is detected by the furnace control board, the indoor unit blower engages and remains engaged at a constant air flow output until the fault is cleared.

**NOTE** - See "IGNITION CONTROL DIAGNOSTIC CODES" on page 30 for Low GWP diagnostic error codes.

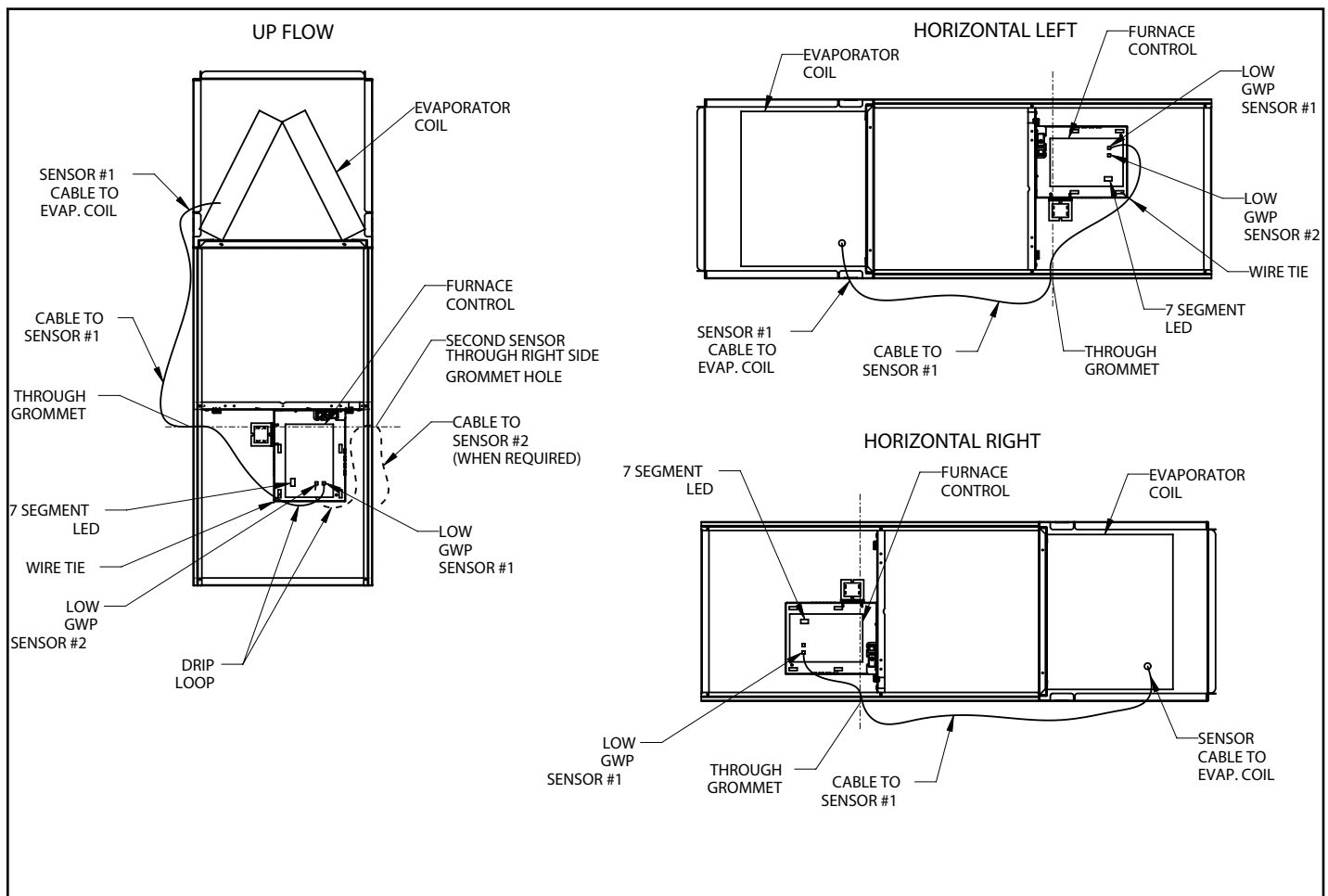

Figure 36.

## LGWP TEST BUTTON FUNCTIONALITY

The furnace control board is equipped with a Test/Reset push button. The Test button can be used to perform several functions, depending on the mode of operation of the furnace control board.

Table 12 lists the functions of the Test button during each mode of operation.

**Table 12.**  
**LGWP Test Button Function**

Mode of Operation	Press the Test Button to:
Normal	Trigger a leak detection response. Verify all equipment is wired correctly into the furnace blower control board (after installation).
Leak Detected	Reset the furnace control board to a normal mode of operation after a previous leak has been detected and purged from the HVAC system
Fault	Reset the furnace control board after troubleshooting and resolving a fault condition. If the fault is not resolved, the furnace control board will enter the Fault mode again.

### LGWP Test Button - Additional Functions

Table 13 lists the additional functions of the Test Button while the furnace control board is functioning within the states of Initializing, Monitoring, Leak Detection, Servicing and Fault.

**Table 13.**  
**Additional Button Functions**

State	Press	Action
Initializing	Short	Skips remaining pre-purge after sensors are recognized by the furnace control board
Initializing	Long	Reset control
Monitoring	Short	Clear purge-counter if prior mitigation has occurred; Test mitigation
Monitoring	Long	Reset control
Mitigating	Short	If testing mitigation, end test
Servicing	Short	Reevaluate fault condition - if cleared return to monitoring, otherwise update indicator
Servicing	Long	Reset control
Fault	Short	Reevaluate fault condition - if cleared return to monitoring, otherwise update indicator
Fault	Long	Reset control

### External Alarm

*(For applications with external alarms wired directly to the furnace control board)*

The furnace control board triggers the external alarm system when it enters Leak Detected mode. For alarm notifications, the furnace control board provides a dry relay contact that is rated 3A at 30 VAC/DC.

### THERMOSTAT COMPATIBILITY

Thermostats that preserve memory settings are compatible with the furnace control board. Examples include:

- Battery-powered thermostats
- Analog Thermostat
- Late-model programmable thermostats

**NOTE** - *Early-generation digital and programmable thermostats may not retain the operation mode and temperature setpoints after a power outage.*

The following scenarios are likely to occur when home occupants are not available to adjust the thermostat setpoints as the system is recovering from leak detection and resuming normal operation:

- Heating could be lost during a cold night
- Cooling could be lost during a hot day
- The thermostat could reset to an incorrect temperature setpoint

### START UP PROCEDURE

The furnace control board is equipped with a LGWP Test/Reset button, see Test Button Functionality. After the furnace control board has been mounted and wired, restore power to the HVAC system. The system will then run through a purge sequence for five minutes. After the purge sequence is complete, proceed to testing cooling demand and heating demand.

#### Cooling Demand

1. Prompt a cooling demand at the thermostat.
2. Press the LGWP Test button on the furnace control board.  
The system then executes a leak detection response.
3. Observe the following sequence:
  - a. The LED indicator for leak detection. See "IGNITION CONTROL DIAGNOSTIC CODES" on page 30.
  - b. The blower powers up.
  - c. The outdoor compressor powers down.
4. Press the LGWP Test button to terminate the simulated Leak Detected mode upon test completion

#### Heating Demand

1. Prompt a heating demand at the thermostat.
2. Observe the following sequence:
  - a. The LED indicator for leak detection. See "IGNITION CONTROL DIAGNOSTIC CODES" on page 30.
  - b. The blower powers up.
  - c. The gas burners power down.
  - d. The outdoor compressor powers down.
3. Press the LGWP Test button to terminate the simulated Leak Detected mode upon test completion.

The installation of the furnace control board is complete after both sequences are successfully completed.

## Integrated Control DIP Switch Settings

A80UH2EK & 80G2UHE(L)K units are equipped with a two-stage integrated control. This control manages ignition timing, heating mode fan off delays and indoor blower speeds based on selections made using the control dip switches and jumpers. The control includes an internal watchdog feature which automatically resets the ignition control when it has been locked out. After one hour of continuous thermostat demand for heat, the watchdog will break and remake thermostat demand to the furnace and automatically reset the control to relight the furnace.

### Heating Operation DIP Switch Settings

**Switch 1 -- Thermostat Selection --** This unit may be used with either a single-stage or two-stage thermostat. The thermostat selection is made using a DIP switch which must be properly positioned for the particular application. The DIP switch is factory-positioned for use with a two-stage thermostat. If a single-stage thermostat is to be used, the DIP switch must be repositioned.

1. Select "OFF" for two-stage heating operation controlled by a two-stage heating thermostat (factory setting);
2. Select "ON" for two-stage heating operation controlled by a single-stage heating thermostat. This setting provides a timed delay before second-stage heat is initiated.

**Switch 2 -- Second Stage Delay (Used with Single-Stage Thermostat Only) --** This switch is used to determine the second stage on delay when a single-stage thermostat is being used. The switch is factory-set in the OFF position, which provides a 7-minute delay before second-stage heat is initiated. If the switch is toggled to the ON position, it will provide a 12-minute delay before second-stage heat is initiated. This switch is only activated when the thermostat selector jumper is positioned for SINGLE-stage thermostat use.

### Indoor Blower Operation DIP Switch Settings

**Switches 3 and 4 -- Heating Mode Blower-Off Delay --** The blower-on delay of 30 seconds is not adjustable. The blower-off delay (time that the blower operates after the heating demand has been satisfied) can be adjusted by moving switches 3 and 4 on the integrated control. The unit is shipped from the factory with a blower-off delay of 90 seconds.

The blower off delay affects comfort and is adjustable to satisfy individual applications. Adjust the blower off delay to achieve a supply air temperature between 90° and 110°F at the exact moment that the blower is de-energized. Longer off delay settings provide lower supply air temperatures; shorter settings provide higher supply air temperatures. Table 14 provides the blower off timings that will result from different switch settings.

**Table 14. Blower Off Heating Mode Delay Switch Settings**

Blower Off Delay Seconds	Switch 3	Switch 4
60	On	Off
90 (factory)	Off	Off
120	Off	On
180	On	On

**Switch 5 -- Cooling Mode Blower-Off Delay--** The unit is shipped from the factory with the dip switch positioned OFF for a 45 second delay. Table 15 provides the cooling mode off delay settings.

**Table 15. Blower Off Cooling Mode Delay Switch Settings**

Blower Off Delay Seconds	Switch 5
45 (factory)	Off
2	On

**Switches 6 and 7 -- Continuous Fan Mode --** Low Heat Speed is the only available setting for Continuous Fan Mode. See Table 16.

**Table 16. Continuous Fan Mode Settings**

Continuous Fan Mode	Switch 6	Switch 7
Low Heat Speed (factory)	Off	Off

**Switch 8 -** DIP Switch 8 is not powered and not used. Switching from on/off will not change any output.

## On-Board Links and Diagnostic Push Button

### WARNING

Carefully review all configuration information provided. Failure to properly set DIP switches, jumpers and on-board links can result in improper operation!

### On-Board Link W914 Dehum

On-board link W914, is a clippable connection between terminals R and DS on the integrated control. W914 must be cut when the furnace is installed with a thermostat which features humidity control. If the link is not cut, terminal "DS" will remain energized not allowing the blower to reduce to low cool speed upon a call for dehumidification.

### On-Board Jumper Heat Pump (R to O)

On-board Jumper is a clippable connection between terminals R and O on the integrated control. W951 must be cut when the furnace is installed in applications which include a heat pump unit and a thermostat which features dual fuel use. If the link is left intact, terminal "O" will remain energized eliminating the HEAT MODE in the heat pump.

### On-Board Jumper 2 Stage Compr (Y1 to Y2)

On-board Jumper is a clippable connection between terminals Y1 and Y2 on the integrated control. Jumper must be cut if two-stage cooling will be used. If the Y1 to Y2 link is not cut the outdoor unit will operate in second-stage cooling only.

### Diagnostic Push Button

The diagnostic push button is located adjacent to the seven-segment diagnostic LED. This button is used to enable the Error Code Recall "E" mode and the Flame Signal "F" mode. Press the button and hold it to cycle through a menu of options. Every five seconds a new menu item will be displayed. When the button is released, the displayed item will be selected. Once all items in the menu have been displayed, the menu resumes from the beginning until the button is released.

## Unit Start-Up

### FOR YOUR SAFETY, READ BEFORE LIGHTING UNIT

#### WARNING

Do not use this furnace if any part has been underwater. A flood-damaged furnace is extremely dangerous. Attempts to use the furnace can result in fire or explosion. Immediately call a qualified service technician to inspect the furnace and to replace all gas controls, control system parts, and electrical parts that have been wet or to replace the furnace, if deemed necessary.

#### WARNING

If overheating occurs or if gas supply fails to shut off, shut off the manual gas valve to the appliance before shutting off electrical supply.

#### CAUTION

Before attempting to perform any service or maintenance, turn the electrical power to unit OFF at disconnect switch.

**BEFORE LIGHTING** smell all around the appliance area for gas. Be sure to smell next to the floor because some gas is heavier than air and will settle on the floor.

The gas valve on this unit will be equipped with a gas control switch. Use only your hand to move the switch. Never use tools. If the switch will not turn or if the control switch will not move by hand, do not try to repair it.

### Placing the Furnace into Operation

These units are equipped with an automatic ignition system. Do not attempt to manually light burners on these furnaces. Each time the thermostat calls for heat, the burners will automatically light. The ignitor does not get hot when there is no call for heat on units with an automatic ignition system.

#### WARNING

If you do not follow these instructions exactly, a fire or explosion may result causing property damage, personal injury or death.

### Gas Valve Operation

See Figure 37 or Figure 38

1. **STOP!** Read the safety information at the beginning of this section.
2. Set the thermostat to the lowest setting.
3. Turn off all electrical power to the unit.
4. This furnace is equipped with an ignition device which automatically lights the burners. Do not try to light the burners by hand.
5. Remove the upper access panel.
6. Move switch on gas valve to OFF. Do not force. See Figure 37 or Figure 38.
7. Wait five minutes to clear out any gas. If you then smell gas, **STOP!** Immediately call your gas supplier from a neighbor's phone. Follow the gas supplier's instructions.
8. Move switch on gas valve to ON. Do not force. See Figure 37 or Figure 38.
9. Replace the upper access panel.
10. Turn on all electrical power to the unit.
11. Set the thermostat to desired setting.

**NOTE:** When unit is initially started, steps 1 through 11 may need to be repeated to purge air from gas line.

12. If the appliance will not operate, follow the instructions "Turning Off Gas to Unit" and call your service technician or gas supplier.

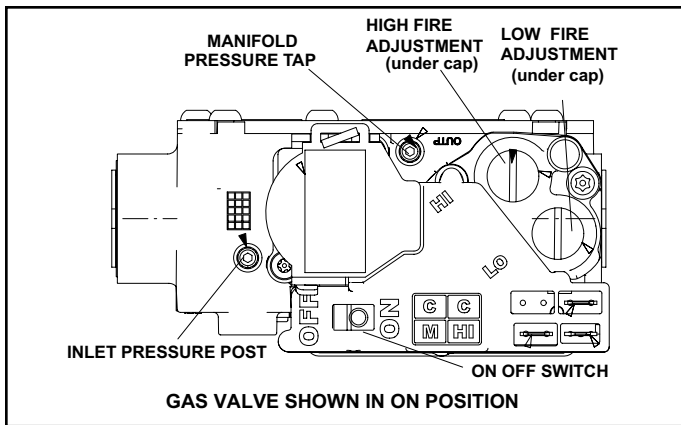

**Figure 37. White Rodgers Gas Valve**

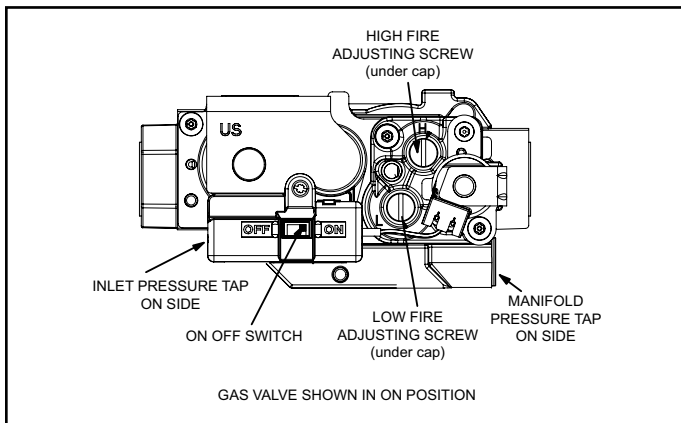

**Figure 38. Resideo Two-Stage Gas Valve**

### Turning Off Gas to Unit

1. Set the thermostat to the lowest setting.
2. Turn OFF all electrical power to the unit if service is to be performed.
3. Remove the upper access panel.
4. Move switch on gas valve to OFF. Do not force.
5. Replace the upper access panel.

### Failure to Operate

If the unit fails to operate, check the following:

1. Is the thermostat calling for heat?
2. Are access panels securely in place?
3. Is the main disconnect switch closed?
4. Is there a blown fuse or tripped circuit breaker?
5. Is the filter dirty or plugged? Dirty or plugged filters will cause the limit control to shut the unit off.
6. Is gas turned on at the meter?
7. Is the manual main shut-off valve open?
8. Is the internal manual shut-off valve open?
9. Is the unit ignition system in lock out? If the unit locks

out again, call the service technician to inspect the unit for blockages.

10. Is pressure switch closed? Obstructed flue will cause unit to shut off at pressure switch. Check flue and outlet for blockages.
11. Are flame rollout switches tripped? If flame rollout switches are tripped, call the service technician for inspection.

### Gas Pressure Adjustment Gas Flow (Approximate)

**Table 17.**

Gas Meter Clocking Chart				
Capacity	Seconds for One Revolution			
	Natural		LP	
	1 cu ft Dial	2 cu ft Dial	1 cu ft Dial	2 cu ft Dial
-045	80	160	200	400
-070	55	110	136	272
-090	41	82	102	204
-110	33	66	82	164
Natural - 1000 btu/cu ft			LP - 2500 btu/cu ft	

Furnace should operate at least 5 minutes before checking gas flow. Determine time in seconds for two revolutions of gas through the meter. (Two revolutions assures a more accurate time.) Divide by two and compare to time in Table 17. If manifold pressure matches Table 19 and rate is incorrect, check gas orifices for proper size and restriction. Remove temporary gas meter if installed.

**NOTE:** To obtain accurate reading, shut off all other gas appliances connected to meter.

### Supply Pressure Measurement

An inlet post located on the gas valve provides access to the supply pressure. See Figure 37 or Figure 38. Back out the 3/32" hex screw one turn, connect a piece of 5/16" tubing and connect to a manometer to measure supply pressure. See Table 19 for supply line pressure.

### Manifold Pressure Measurement

A manifold pressure tap located on the gas valve provides access to the manifold pressure. See Figure 37 or Figure 38. Back out the 3/32" hex screw one turn, connect a piece of 5/16" tubing and connect to a manometer to measure manifold pressure.

**NOTE:** Pressure test adapter kit (10L34) is available Blue Summit to facilitate manifold pressure measurement.

1. Connect test gauge to manifold pressure tap (Figure

37 or Figure 38) gas valve.

2. Ignite unit on low fire and let run for 5 minutes to allow for steady state conditions.
3. After allowing unit to stabilize for 5 minutes, record manifold pressure and compare to value given in Table 19.
4. If necessary, make adjustments. Figure 37 and Figure 38 show location of high fire and low fire adjustment screw.
5. Repeat steps 2, 3 and 4 on high fire.
6. Shut unit off and remove manometer as soon as an accurate reading has been obtained. Turn the supply and manifold 3/32" hex screw one revolution back into the gas valve.
7. Start unit and check for gas leaks. Seal if any found.

### Proper Combustion

Furnace should operate a minimum 15 minutes with correct manifold pressure and gas flow rate before checking combustion. Table 18 shows acceptable combustion for all A80UH2EK & 80G2UHE(L)K models. **The maximum carbon monoxide reading should not exceed 100 ppm.**

**Table 18.**

Capacity	CO <sub>2</sub> % for Nat	CO <sub>2</sub> % for LP
High Fire	6.0 - 7.5	7.0 - 8.5
Low Fire	5.0 - 6.5	5.8 - 7.3

### High Altitude

The manifold pressure may require adjustment and combustion air pressure switch may need replacing to ensure proper combustion at higher altitudes. Refer to Table 19 for manifold pressure and Table 20 for pressure switch change and gas conversion kits.

**Table 19. Manifold Pressure and Line Pressure at Various Altitudes**

Capacity	Gas	Manifold Pressure in. wg. 0 - 4,500 ft.		Manifold Pressure in. wg. 4,501 - 7,500 ft.		Manifold Pressure in. wg. 7,501 - 10,000 ft. <sup>2</sup>		Supply Line Pressure in. wg.	
		Low Fire	High Fire	Low Fire	High Fire	Low Fire	High Fire	Min.	Max.
045	Natural	1.7	3.5	1.5	3.2	1.7	3.5	4.5	13.0
	LP/Propane <sup>3</sup>	4.5	10.0	4.5	10.0	4.5	10.0	11.0	13.0
070	Natural	1.7	3.5	1.6	3.4	1.7	3.5	4.5	13.0
	LP/Propane <sup>3</sup>	4.5	10.0	4.5	10.0	4.5	10.5	11.0	13.0
090	Natural	1.7	3.5	1.5	3.2	1.7	3.5	4.5	13.0
	LP/Propane <sup>3</sup>	4.5	10.0	4.5	10.0	4.5	10.0	11.0	13.0
110	Natural	1.7	3.5	1.5	2.8	1.7	3.5	4.5	13.0
	LP/Propane <sup>3</sup>	4.5	10.0	4.5	10.0	4.5	10.0	11.0	13.0

1. This is the only permissible derate for these units.
2. Natural gas high altitude orifice kit required.
3. A natural to L.P. propane gas changeover kit is necessary to convert this unit. Refer to the changeover kit installation instruction for the conversion procedure.

NOTE - Units may be installed at altitudes up to 4500 ft. above sea level without modifications.

**Table 20. Orifice Kits and Pressure Switch Kits at Various Altitudes**

Capacity	High Altitude Pressure Switch Kit			High Altitude Natural Gas Orifice Kit	Natural to LP/Propane Kit		LP/Propane to Natural Kit
	0 - 4,500 ft.	4,501 - 7,500 ft.	7,501 - 10,000 ft.	7,501 - 10,000 ft.	0 - 7,500 ft.	7,501 - 10,000 ft.	0 - 7,500 ft.
All	No Change	91W53	73W35	51W01	11K48	11K47	77W10

NOTE: A natural to LP/Propane gas changeover kit is necessary to convert this unit. Refer to the changeover kit installation instruction for the conversion procedure.

## Other Unit Adjustments

### Primary and Secondary Limits

The primary limit is located on the heating compartment vestibule panel. The secondary limits (if equipped) are located in the blower compartment, attached to the back side of the blower. These auto reset limits are factory-set and require no adjustment.

### Flame Rollout Switches

This manually reset switches are located on the baffle plate in the burner assembly.

### Pressure Switch

The pressure switch is located in the heating compartment adjacent to the combustion air inducer. The switch checks for proper combustion air inducer operation before allowing ignition trial. The switch is factory-set and requires no adjustment.

### Temperature Rise

After the furnace has been started, and supply and return air temperatures have been allowed to stabilize, check the temperature rise. If necessary, adjust the blower speed to maintain the temperature rise within the range shown on the unit nameplate. See Table 21 for allowable heating speeds. Increase the blower speed to decrease the temperature. Decrease the blower speed to increase the temperature rise. Failure to adjust the temperature rise may cause erratic limit operation.

### Electrical

1. Check all wiring for loose connections.
2. Check for the correct voltage at the furnace (furnace operating). Correct voltage is 120VAC + 10%.
3. Check amp-draw on the blower motor with inner blower panel in place.

Unit Nameplate \_\_\_\_\_ Actual \_\_\_\_\_

### Blower Speeds

Follow the steps below to change the blower speeds.

1. Turn off electrical power to furnace.
2. Remove blower access panel.
3. Disconnect existing speed tap at integrated control speed terminal.

**NOTE:** *Termination of any unused motor leads must be insulated.*

4. Place unused blower speed tap on integrated control "PARK" terminal or insulate.
5. Refer to blower speed selection chart on unit wiring diagram for desired heating or cooling speed. See Blower performance data at the end of this manual and Table 21 for allowable heating speeds.

6. Connect selected speed tap at integrated control speed terminal.
7. Resecure blower access panel.
8. Turn on electrical power to furnace.
9. Recheck temperature rise.

## Heating Sequence of Operation

### Electronic Ignition

The two-stage, variable speed integrated control used in A80UH2EK & 80G2UHE(L)K units has an added feature of an internal Watchguard control. The feature serves as an automatic reset device for ignition control lockout caused by ignition failure. After one hour of continuous thermostat demand for heat, the Watchguard will break and remake thermostat demand to the furnace and automatically reset the control to begin the ignition sequence.

**NOTE:** *The ignition control thermostat selection DIP switch is factory-set in the "TWO-STAGE" position.*

### Applications Using a Two-Stage Thermostat

#### **A - Heating Sequence -- Integrated Control Thermostat Selection DIP Switch 1 OFF in "Two-Stage" Position (Factory Setting)**

1. On a call for heat, thermostat first-stage contacts close sending a signal to the integrated control. The integrated control runs a self-diagnostic program and checks high temperature limit switches for normally closed contacts and pressure switches for normally open contacts. The combustion air inducer is energized at low speed.
2. Once the control receives a signal that the low pressure switch has closed, the combustion air inducer begins a 15-second pre-purge in low speed.

**NOTE:** *If the low fire pressure switch does not close the combustion air inducer will switch to high fire. After a 15 second pre-purge the high fire pressure switch will close and the unit will begin operation on high fire. After 10 to 20 seconds of high fire operation the unit will switch to low fire.*

3. After the pre-purge is complete, a 20-second initial ignitor warm-up period begins. The combustion air inducer continues to operate at low speed.
4. After the 20-second warm-up period has ended, the gas valve is energized on low fire (first stage) and ignition occurs. At the same time, the control module sends a signal to begin an indoor blower 30-second ON-delay. When the delay ends, the indoor blower motor is energized on the low fire heating speed, the HUM contacts close energizing the humidifier and 120V ACC terminal is energized. The furnace will continue this operation as long as the thermostat has a first-stage heating demand.

5. If second-stage heat is required, the thermostat second-stage heat contacts close and send a signal to the integrated control. The integrated control initiates a 30-second second-stage recognition delay.
  6. At the end of the recognition delay, the integrated control energizes the combustion air inducer at high speed. The control also checks the high fire (second-stage) pressure switch to make sure it is closed. The high fire (second stage) gas valve is energized and the indoor blower motor is energized for operation at the high fire heating speed.
  7. When the demand for high fire (second stage) heat is satisfied, the combustion air inducer is switched to the low-fire heating speed and the high-fire (second-stage) gas valve is de-energized. The low-fire (first-stage) gas valve continues operation. The indoor blower motor is switched to the low-fire heating speed.
  8. When the thermostat demand for low-fire (first stage) heat is satisfied, the gas valve is de-energized and the field-selected indoor blower off delay begins. The combustion air inducer begins a 5-second postpurge period.
  9. When the combustion air post-purge period is complete, the inducer and the HUM contacts are deenergized. The indoor blower is de-energized at the end of the off delay as well as the ACC terminals.
4. After the 20-second warm-up period has ended, the gas valve is energized on low fire (first stage) and ignition occurs. At the same time, the control module sends a signal to begin an indoor blower 30-second ON-delay. When the delay ends, the indoor blower motor is energized on the low fire heating speed and the HUM contacts are energized. The integrated control also initiates a second-stage on delay (factory-set at 7 minutes; adjustable to 12 minutes).
  5. If the heating demand continues beyond the second-stage on delay, the integrated control energizes the combustion air inducer at high speed. The control also checks the high fire (second stage) pressure switch to make sure it is closed. The high fire (second stage) gas valve is energized and the indoor blower motor is energized for operation at the high fire heating speed.
  6. When the thermostat heating demand is satisfied, the combustion air inducer begins a 5-second low speed post-purge. The field-selected indoor blower off delay begins. The indoor blower operates at the low-fire heating speed.
  7. When the combustion air post-purge period is complete, the inducer and the HUM contacts are deenergized. The indoor blower is de-energized at the end of the off delay as well as the 120 ACC terminals.

## Applications Using A Single-Stage Thermostat

### ***B - Heating Sequence -- Integrated Control Thermostat Selection DIP Switch 1 ON in "Single-Stage" Position***

**NOTE:** *In these applications, two-stage heat will be initiated by the integrated control if heating demand has not been satisfied after the field adjustable period (7 or 12 minutes).*

1. On a call for heat, thermostat first-stage contacts close sending a signal to the integrated control. The integrated control runs a self-diagnostic program and checks high temperature limit switches for normally closed contacts and pressure switches for normally open contacts. The combustion air inducer is energized at low speed.
2. Once the control receives a signal that the low pressure switch has closed, the combustion air inducer begins a 15-second pre-purge in low speed.

**NOTE:** *If the low fire pressure switch does not close the combustion air inducer will switch to high fire. After a 15 second pre-purge the high fire pressure switch will close and the unit will begin operation on high fire. After 10 to 20 seconds of high fire operation the unit will switch to low fire.*

3. After the pre-purge is complete, a 20-second initial ignitor warm-up period begins. The combustion air inducer continues to operate at low speed.

## Service

### **WARNING**

#### **ELECTRICAL SHOCK, FIRE, OR EXPLOSION HAZARD.**

Failure to follow safety warnings exactly could result in dangerous operation, serious injury, death or property damage.

Improper servicing could result in dangerous operation, serious injury, death, or property damage. Before servicing, disconnect all electrical power to furnace.

When servicing controls, label all wires prior to disconnecting. Take care to reconnect wires correctly.

Verify proper operation after servicing.

### **WARNING**

The blower access panel must be securely in place when the blower and burners are operating. Gas fumes, which could contain carbon monoxide, can be drawn into living space resulting in personal injury or death.

## Annual Furnace Maintenance

At the beginning of each heating season, and to comply with the Allied Air Limited Warranty, your system should be checked as follows:

1. Check wiring for loose connections, voltage at indoor unit and amperage of indoor motor.
2. Check the condition of the belt and shaft bearings if applicable.
3. Inspect all gas pipe and connections for leaks.
4. Check the cleanliness of filters and change if necessary (monthly).
5. Check the condition and cleanliness of burners and heat exchanger and clean if necessary.
6. Check the cleanliness of blower assembly and clean the housing, blower wheel and blower motor if necessary.
7. Inspect the combustion air inducer and clean if necessary.
8. Evaluate the heat exchanger integrity by inspecting the heat exchanger per the AHRI heat exchanger inspection procedure. This procedure can be viewed at [www.ahrinet.org](http://www.ahrinet.org).
9. Ensure sufficient combustion air is available to the furnace. Fresh air grilles and louvers (on the unit and in the room where the furnace is installed) must be properly sized, open and unobstructed to provide combustion air.
10. Inspect the furnace venting system to make sure it is in place, structurally sound, and without holes, corrosion, or blockage. Vent system must be free and clear of obstructions and must slope upward away from the furnace. Vent system should be installed per the National Fuel Gas Code.
11. Inspect the furnace return air duct connection to ensure the duct is sealed to the furnace. Check for air leaks on supply and return ducts and seal where necessary.
12. Check the condition of the furnace cabinet insulation and repair if necessary.
13. Perform a complete combustion analysis during the furnace inspection to ensure proper combustion and operation. Consult Service Literature for proper combustion values.
14. Verify operation of CO detectors and replace batteries as required.

Perform a general system test. Turn on the furnace to check operating functions such as the start-up and shutoff operation.

1. Check the operation of the ignition system, inspect and clean flame sensor. Check microamps before and after. Check controls and safety devices (gas valve, flame sensor, temperature limits). Consult Service Manual for proper operating range. Thermal Limits should be checked by restricting airflow and not disconnecting the indoor blower. For additional details, please see Service and Application Note H049.
2. Verify that system total static pressure and airflow settings are within specific operating parameters.
3. Clock gas meter to ensure that the unit is operating at the specified firing rate. Check the supply pressure and the manifold pressure. On two-stage gas furnaces check the manifold pressure on high fire and low fire. If manifold pressure adjustment is necessary, consult the Service Literature for unit specific information on adjusting gas pressure. Not all gas valves are adjustable. Verify correct temperature rise.

## Cleaning the Burners

**NOTE:** Use papers or protective covering in front of the furnace during cleaning.

1. Turn off both electrical and gas power supplies to furnace.
2. Label the wires from gas valve, rollout switches, primary limit switch and make-up box then disconnect them.
3. Disconnect gas supply piping. Remove the screw securing the burner box cover and remove cover. Remove the four screws securing the burner manifold assembly to the vestibule panel and remove the assembly from the unit.
4. To clean burners, run a vacuum cleaner with a soft brush attachment over the face of burners. Visually inspect inside the burners and crossovers for any blockage caused by foreign matter. Remove any blockage. Figure 39 shows burner detail.
5. Reinstall burner box, manifold assembly and burner box cover.
6. Re-install gas supply and turn on electrical power to furnace.

## Low GWP Sensor/Sleeve

Inspect the low GWP sensor / sensors and rubber sleeve.

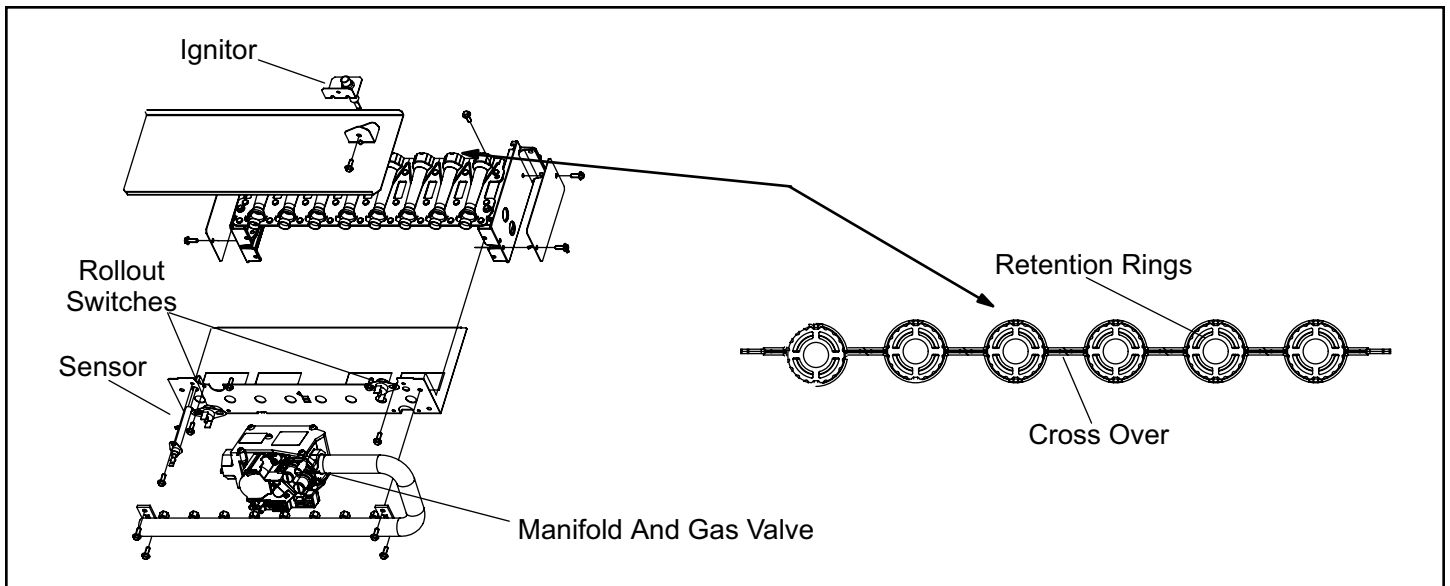

**Figure 39. Burner Removal**

## Repair Parts List

The following repair parts are available through independent Allied Air dealers. When ordering parts, include the complete furnace model number listed on the CSA International nameplate. All service must be performed by a licensed professional HVAC installer (or equivalent), service agency, or gas supplier.

### Cabinet Parts

- Main access panel
- Blower panel
- Top cap

### Control Panel Parts

- Transformer
- Integrated control
- Door interlock switch
- Circuit breaker

### Blower Parts

- Blower wheel
- Blower housing
- Motor
- Motor mounting frame
- Motor capacitor
- Blower housing cutoff plate

### Heating Parts

- Flame sensor
- Heat exchanger assembly
- Gas manifold
- Combustion air inducer
- Gas valve
- Main burner cluster
- Main burner orifices
- Pressure switch
- Ignitor
- Primary limit control
- Flame rollout switch (s)
- Secondary limit

### Refrigerant Detection System Parts

- Refrigerant Detection Sensor
- Refrigerant Line Set Sleeve

## Blower Performance

### A80UH2E045A12K/80G2UH045AE12K PERFORMANCE (Less Filter)

External Static Pressure in. w.g.	Air Volume / Watts at Various Blower Speeds									
	High (Black)		Medium-High (Brown)		Medium (Blue)		Medium-Low (Yellow)		Low (Red)	
	cfm	Watts	cfm	Watts	cfm	Watts	cfm	Watts	cfm	Watts
0.10	1436	310	1199	175	1022	113	875	79	875	82
0.20	1431	315	1166	183	987	120	747	68	714	62
0.30	1413	324	1138	192	938	129	696	76	514	49
0.40	1378	337	1104	199	905	137	640	81	448	55
0.50	1350	345	1070	206	858	146	588	87	367	60
0.60	1321	357	1031	215	824	152	533	93	311	65
0.70	1292	366	993	226	773	159	488	98	272	69
0.80	1267	378	969	233	737	165	426	104	232	73
0.90	1239	385	926	243	691	173	382	108	-	-
1.00	1210	394	891	250	649	179	-	-	-	-

### A80UH2E070A12K/80G2UH070AE12K PERFORMANCE (Less Filter)

External Static Pressure in. w.g.	Air Volume / Watts at Various Blower Speeds									
	High (Black)		Medium-High (Brown)		Medium (Blue)		Medium-Low (Yellow)		Low (Red)	
	cfm	Watts	cfm	Watts	cfm	Watts	cfm	Watts	cfm	Watts
0.10	1449	325	1328	256	1183	189	946	111	782	75
0.20	1419	335	1297	266	1148	197	904	118	736	81
0.30	1391	345	1267	276	1114	206	862	124	689	87
0.40	1363	356	1236	285	1081	214	822	131	639	93
0.50	1334	366	1206	294	1047	223	780	138	594	98
0.60	1307	376	1177	304	1013	231	740	145	548	104
0.70	1279	386	1146	313	981	239	700	151	506	109
0.80	1250	397	1115	322	946	246	661	158	451	115
0.90	1222	406	1084	331	913	254	624	163	399	120
1.00	1193	415	1054	339	881	262	588	169	357	125

### A80UH2E090B12K/80G2UH090BE12K PERFORMANCE (Less Filter)

External Static Pressure in. w.g.	Air Volume / Watts at Various Blower Speeds									
	High (Black)		Medium-High (Brown)		Medium (Blue)		Medium-Low (Yellow)		Low (Red)	
	cfm	Watts	cfm	Watts	cfm	Watts	cfm	Watts	cfm	Watts
0.10	1537	284	1409	226	1249	167	1002	103	829	70
0.20	1499	295	1369	236	1206	176	951	109	770	77
0.30	1464	307	1331	247	1164	185	900	117	709	84
0.40	1428	318	1294	257	1125	195	847	125	641	91
0.50	1395	330	1259	267	1084	204	791	132	573	97
0.60	1361	340	1222	278	1041	213	738	140	527	103
0.70	1329	352	1184	288	993	223	688	146	458	109
0.80	1293	363	1145	298	946	231	638	153	381	115
0.90	1256	374	1104	308	909	239	589	159	333	120
1.00	1218	385	1066	318	862	248	533	166	312	123

## Blower Performance

### A80UH2E090B16K/80G2UH090BE16K PERFORMANCE (Less Filter)

External Static Pressure in. w.g.	Air Volume / Watts at Various Blower Speeds									
	High (Black)		Medium-High (Brown)		Medium (Blue)		Medium-Low (Yellow)		Low (Red)	
	cfm	Watts	cfm	Watts	cfm	Watts	cfm	Watts	cfm	Watts
0.10	1724	384	1514	271	1392	218	1308	189	1182	148
0.20	1691	399	1477	284	1354	230	1268	200	1139	158
0.30	1659	412	1442	295	1317	242	1229	211	1097	168
0.40	1629	427	1408	308	1280	253	1189	221	1048	177
0.50	1599	440	1372	320	1239	264	1145	231	999	187
0.60	1569	453	1336	332	1195	274	1097	240	955	195
0.70	1536	466	1298	343	1153	285	1050	249	908	203
0.80	1503	479	1256	353	1111	295	1008	258	864	211
0.90	1469	491	1218	364	1070	304	970	266	819	218
1.00	1432	503	1181	374	1031	313	931	275	784	226

### A80UH2E110C16K/80G2UH110CE16K PERFORMANCE (Less Filter)

External Static Pressure in. w.g.	Air Volume / Watts at Various Blower Speeds									
	High (Black)		Medium-High (Brown)		Medium (Blue)		Medium-Low (Yellow)		Low (Red)	
	cfm	Watts	cfm	Watts	cfm	Watts	cfm	Watts	cfm	Watts
0.10	1785	355	1565	251	1438	204	1351	177	1217	139
0.20	1749	369	1524	264	1396	216	1307	188	1170	148
0.30	1714	383	1486	276	1355	226	1264	198	1122	158
0.40	1679	397	1447	288	1315	238	1220	208	1076	168
0.50	1644	411	1408	300	1272	249	1176	218	1023	177
0.60	1610	425	1369	312	1229	259	1129	228	972	186
0.70	1576	437	1328	323	1186	270	1080	238	922	196
0.80	1538	448	1287	335	1139	280	1034	248	871	203
0.90	1500	461	1246	346	1096	290	988	257	824	212
1.00	1464	474	1206	357	1053	300	943	266	780	218

# Blower Performance

## A80UH2E110C20K/80G2UH110CE20K PERFORMANCE (Less Filter)

External Static Pressure in. w.g.		Air Volume / Watts at Different Blower Speeds																																						
		Bottom Return Air, Side Return Air from Both Sides or Return Air from Bottom and One Side.									Single Side Return Air - Air volumes in bold (over 1800 cfm) require Optional Return Air Base and field fabricated transition to accommodate 20 x 25 x 1 in. air filter in order to maintain proper air velocity.																													
		High (Black)			Medium-High (Brown)			Medium (Blue)			Medium-Low (Yellow)			Low (Red)			High (Black)			Medium-High (Brown)			Medium (Blue)			Medium-Low (Yellow)			Low (Red)											
cfm	Watts		cfm	Watts		cfm	Watts		cfm	Watts		cfm	Watts		cfm	Watts		cfm	Watts		cfm	Watts		cfm	Watts		cfm	Watts		cfm	Watts									
0.10	2173	601	1934	431	1772	335	1654	281	1468	206	2164	611	1911	430	1762	336	1647	279	1473	201	2126	631	1876	444	1718	350	1608	294	1424	212	2092	646	1839	458	1673	361	1563	306	1373	226
0.20	2147	613	1900	444	1736	346	1626	290	1445	214	2055	662	1800	474	1638	374	1520	317	1324	237	2016	678	1764	488	1594	388	1477	328	1275	247	1986	691	1727	501	1556	401	1440	339	1230	259
0.30	2109	630	1873	456	1701	356	1585	303	1361	227	1967	705	1684	515	1521	411	1394	352	1172	270	2016	678	1764	488	1594	388	1477	328	1275	247	1986	691	1727	501	1556	401	1440	339	1230	259
0.40	2085	643	1833	471	1657	369	1547	314	1343	235	1967	705	1684	515	1521	411	1394	352	1172	270	2016	678	1764	488	1594	388	1477	328	1275	247	1986	691	1727	501	1556	401	1440	339	1230	259
0.50	2050	658	1800	485	1626	379	1503	327	1298	246	1967	705	1684	515	1521	411	1394	352	1172	270	2016	678	1764	488	1594	388	1477	328	1275	247	1986	691	1727	501	1556	401	1440	339	1230	259
0.60	2019	672	1771	495	1579	393	1480	338	1256	256	1967	705	1684	515	1521	411	1394	352	1172	270	2016	678	1764	488	1594	388	1477	328	1275	247	1986	691	1727	501	1556	401	1440	339	1230	259
0.70	1983	689	1734	509	1543	404	1401	348	1211	265	1967	705	1684	515	1521	411	1394	352	1172	270	2016	678	1764	488	1594	388	1477	328	1275	247	1986	691	1727	501	1556	401	1440	339	1230	259
0.80	1953	703	1693	524	1502	416	1381	361	1176	277	1967	705	1684	515	1521	411	1394	352	1172	270	2016	678	1764	488	1594	388	1477	328	1275	247	1986	691	1727	501	1556	401	1440	339	1230	259
0.90	1925	715	1663	535	1470	426	1343	372	1118	289	1967	705	1684	515	1521	411	1394	352	1172	270	2016	678	1764	488	1594	388	1477	328	1275	247	1986	691	1727	501	1556	401	1440	339	1230	259
1.00	1898	728	1643	544	1441	434	1304	383	1078	297	1967	705	1684	515	1521	411	1394	352	1172	270	2016	678	1764	488	1594	388	1477	328	1275	247	1986	691	1727	501	1556	401	1440	339	1230	259

Model	Cooling Capacity	Low Fire Heating Speeds					High Fire Heating Speeds										
		Red	Yellow	Blue	Brown	Black	Red	Yellow	Blue	Brown	Black						
045	3 ton	Factory Setting	Allowed	Allowed	Allowed	Not Allowed	Not Allowed	Not Allowed	Allowed	Factory Setting	Allowed						
070	3 ton				Allowed							Factory Setting	Not Allowed	Not Allowed	Allowed		
090	3 ton	Allowed	Factory Setting		Factory Setting					Allowed							
090	4 ton	Factory Setting	Allowed													Factory Setting	Allowed
110	4 ton	Allowed	Factory Setting														
110	5 ton	Factory Setting	Allowed	Not Allowed	Factory Setting	Allowed											

**Table 21. Allowable Heating Speeds**

Model	Cooling Capacity	Red	Yellow	Blue	Brown	Black
045	3 ton	Factory Setting	Allowed	Not Allowed	Not Allowed	Not Allowed
070	3 ton					
090	3 ton	Allowed	Factory Setting			
090	4 ton	Factory Setting	Allowed			
110	4 ton	Allowed	Factory Setting			
110	5 ton	Factory Setting	Allowed			

**Table 22. Allowable Circulation Speeds**

# Requirements for Commonwealth of Massachusetts

## Modifications to NFPA-54, Chapter 10

### Revise NFPA-54 section 10.8.3 to add the following requirements:

For all side wall, horizontally vented, gas-fueled equipment installed in every dwelling, building or structure used in whole or in part for residential purposes, including those owned or operated by the Commonwealth and where the side wall exhaust vent termination is less than seven (7) feet above the finished grade in the area of the venting, including but not limited to decks and porches, the following requirements shall be satisfied:

1. **INSTALLATION OF CARBON MONOXIDE DETECTORS.** At the time of installation of the side wall, horizontally vented, gas-fueled equipment, the installing plumber or gas fitter shall observe that a hard-wired carbon monoxide detector with an alarm and battery backup is installed on the floor level where the gas equipment is to be installed. In addition, the installing plumber or gas fitter shall observe that a battery-operated or hard-wired carbon monoxide detector with an alarm is installed on each additional level of the dwelling, building or structure served by the side wall, horizontally vented, gas-fueled equipment. It shall be the responsibility of the property owner to secure the services of qualified licensed professionals for the installation of hard-wired carbon monoxide detectors.
  - a. In the event that the side wall, horizontally vented, gas-fueled equipment is installed in a crawl space or an attic, the hard-wired carbon monoxide detector with alarm and battery backup may be installed on the next adjacent floor level.
  - b. In the event that the requirements of this subdivision cannot be met at the time of completion of installation, the owner shall have a period of thirty (30) days to comply with the above requirements; provided, however, that during said thirty (30) day period, a battery-operated carbon monoxide detector with an alarm shall be installed.
2. **APPROVED CARBON MONOXIDE DETECTORS.** Each carbon monoxide detector as required in accordance with the above provisions shall comply with NFPA 720 and be ANSI/UL 2034 listed and IAS certified.
3. **SIGNAGE.** A metal or plastic identification plate shall be permanently mounted to the exterior of the building at a minimum height of eight (8) feet above grade directly in line with the exhaust vent terminal for the horizontally vented, gas-fueled heating appliance or equipment. The sign shall read, in print size no less than one-half (1/2) inch in size, "**GAS VENT DIRECTLY BELOW. KEEP CLEAR OF ALL OBSTRUCTIONS.**"

4. **INSPECTION.** The state or local gas inspector of the side wall, horizontally vented, gas-fueled equipment shall not approve the installation unless, upon inspection, the inspector observes carbon monoxide detectors and signage installed in accordance with the provisions of 248 CMR 5.08(2)(a) 1 through 4.

### **EXEMPTIONS: The following equipment is exempt from 24 CMR 5.08(2)(a) 1 through 4:**

1. The equipment listed in Chapter 10 entitled "Equipment Not Required to Be Vented" in the most current edition of NFPA 54 as adopted by the Board; and
2. Product Approved side wall, horizontally vented, gas-fueled equipment installed in a room or structure separate from the dwelling, building or structure used in whole or in part for residential purposes.

### **MANUFACTURER REQUIREMENTS - GAS EQUIPMENT VENTING SYSTEM PROVIDED.**

When the manufacturer of Product Approved side wall, horizontally vented, gas-fueled equipment provides a venting system design or venting system components with the equipment, the instructions provided by the manufacturer for installation of the equipment and the venting system shall include:

1. Detailed instructions for the installation of the venting system design or the venting system components: and
2. A complete parts list for the venting system design or venting system.

### **MANUFACTURER REQUIREMENTS - GAS EQUIPMENT VENTING SYSTEM NOT PROVIDED.**

When the manufacturer of Product Approved sidewall, horizontally vented, gas-fueled equipment does not provide the parts for venting the flue gases, but identifies "special venting systems," the following requirements shall be satisfied by the manufacturer:

1. The referenced "special venting system" instructions shall be included with the appliance or equipment installation instructions; and
2. The "special venting systems" shall be Product Approved by the Board, and the instructions for that system shall include a parts list and detailed installation instructions.

**A copy of all installation instructions for all Product Approved side wall, horizontally vented, gas-fueled equipment, all venting instructions, all parts lists for venting instructions, and/or all venting design instructions shall remain with the appliance or equipment at the completion of the installation.**