

ONE-WAY CASSETTE TYPE AIR CONDITIONER

Installation Manual

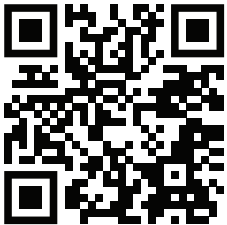

REGISTER YOUR PRODUCT

IMPORTANT NOTE:



Read this manual carefully before installing or operating your new air conditioning unit. Make sure to save this manual for future reference.

CONTENTS

SAFETY PRECAUTIONS	02
PRODUCT OVERVIEW	10
PRODUCT INSTALLATION	11
REFRIGERANT PIPING CONNECTION	24
WIRING PRECAUTIONS	27
AIR EVACUATION	30
NOTE ON ADDING REFRIGERANT	31
ELECTRICAL AND GAS LEAK CHECKS	32
PANEL INSTALLATION	33
TEST RUN	36
PACKING AND UNPACKING THE UNIT	37

SAFETY PRECAUTIONS

It is really important you read Safety Precautions Before Operation and Installation. Incorrect installation due to ignoring instructions can cause serious damage or injury. The seriousness of potential damage or injuries is classified as either a WARNING or CAUTION.

Explanation of Symbols



WARNING

This symbol indicates the possibility of personal injury or loss of life.



CAUTION

This symbol indicates the possibility of property damage or serious consequences.

WARNING

This appliance is not intended for use by persons (including children) with reduced physical, sensory or mental capabilities, or lack of experience and knowledge, unless they have been given supervision or instruction concerning use of the appliance by a person responsible for their safety. Children should be supervised to ensure that they do not play with the appliance.

ELECTRICAL WARNINGS

- Only use the specified wire. If the wire is damaged, it must be replaced by the manufacturer, its service agent or similarly qualified persons in order to avoid a hazard.
- The product must be properly grounded at the time of installation, or electric shock may occur.
- For all electrical work, follow all local and national wiring standards, regulations, and the Installation Manual. Connect cables tightly, and clamp them securely to prevent external forces from damaging the terminal. Improper electrical connections can overheat and cause fire, and may also cause shock. All electrical connections must be made according to the Electrical Connection Diagram located on the panels of the indoor and outdoor units.
- All wiring must be properly arranged to ensure that the control board cover can close properly. If the control board cover is not closed properly, it can lead to corrosion and cause the connection points on the terminal to heat up, catch fire, or cause electrical shock.
- Disconnect must be incorporated in the fixed wiring in accordance with the wiring rules.
- Do not share the electrical outlet with other appliances. Improper or insufficient power supply can cause fire or electric shock.

⚠ WARNINGS FOR PRODUCT INSTALLATION

- Turn off the air conditioner and disconnect the power before performing any installation or repairing. Failure to do so can cause electric shock.
- Installation must be performed by an authorized dealer or specialist. Defective installation can cause water leakage, electrical shock, or fire.
- Installation must be performed according to the installation instructions. Improper installation can cause water leakage, electrical shock, or fire. Contact an authorized service technician for repair or maintenance of this unit.
- This appliance shall be installed in accordance with national wiring regulations. Only use the included accessories, parts, and specified parts for installation.
- Using non-standard parts can cause water leakage, electrical shock, fire, and can cause the unit to fail.
- Install the unit in a firm location that can support the unit's weight. If the chosen location cannot support the unit's weight, or the installation is not done properly, the unit may drop and cause serious injury and damage.
- Install drainage piping according to the instructions in this manual. Improper drainage may cause water damage to your home and property.
- For units that have an auxiliary electric heater, do not install the unit within 1 meter (3 feet) of any combustible materials.
- For the units that have a wireless network function, the USB device access, replacement, maintenance operations must be carried out by professional staff.
- Do not install the unit in a location that may be exposed to combustible gas leaks. If combustible gas accumulates around the unit, it may cause fire.
- Do not turn on the power until all work has been completed.
- When moving or relocating the air conditioner, consult experienced service technicians for disconnection and reinstallation of the unit.
- How to install the equipment: please read the information for details in "indoor unit installation" and "outdoor unit installation" sections.

TAKE NOTE OF FUSE SPECIFICATIONS

The air conditioner's circuit board (PCB) is designed with a fuse to provide overcurrent protection. The specifications of the fuse are printed on the circuit board, for example : T3.15AL/250VAC, T5AL/250VAC, T3.15A/250VAC, T5A/250VAC, T20A/250VAC, T30A/250VAC,etc.

NOTE: Only the blast-proof ceramic fuse can be used.

⚠ WARNING FOR USING FLAMMABLE REFRIGERANTS

- Do not use means to accelerate the defrosting process or to clean, other than those recommended by the manufacturer.
- The appliance shall be stored in a room without continuously operating ignition sources (for example: open flames, an operating gas appliance or an operating electric heater).
- Do not pierce or burn.
- Be aware that refrigerants may not contain an odor.

For R454B refrigerant charge amount and minimum room area:

The machine you purchased may be one of the types in the table below. The indoor and outdoor units are designed to be used together. Please check the machine you purchased. The indoor unit should be installed at least 8.3ft/2.5m above from the floor, the height of the room cannot be less than 7.3ft/2.2m, and the minimum room area of operating or storage should be as specified in the following table:

For the units with refrigerant sensors, when the unit detects a refrigerant leak, the minimum airflow of the indoor unit is as follows:

Model	Indoor unit	Outdoor unit	Indoor Nominal air volume	
6K	BZ33-OWCASS06-454-G3-P	BZ33-HYP06OUT2-454-G3-P	580m ³ /h	342CFM
9K	BZ33-OWCASS09-454-G3-P	BZ33-HYP09OUT2-454-G3-P	580m ³ /h	342CFM
12K	BZ33-OWCASS12-454-G3-P	BZ33-HYP12OUT2-454-G3-P	600m ³ /h	353CFM
18K	BZ33-OWCASS18-454-G3-P	BZ33-HYP18OUT2-454-G3-P	680m ³ /h	400CFM

A_{min} [ft²/m²]	h_{inst}[ft/m]				
m_c or m_{REL} [oz/kg]	6.0~7.3/ 1.8~2.2	7.6/2.3	8.3/2.5	8.9/2.7	9.9/3.0
≤62.6/1.776	12/1.10				
63.4/1.8	60/5.53	57/5.29	53/4.87	49/4.51	44/4.06
70.5/2.0	67/6.15	64/5.88	59/5.41	54/5.01	49/4.51
77.5/2.2	73/6.76	70/6.47	65/5.95	60/5.51	54/4.96
84.6/2.4	80/7.38	76/7.06	70/6.49	65/6.01	59/5.41
91.7/2.6	86/7.99	83/7.64	76/7.03	71/6.51	64/5.86
98.7/2.8	93/8.60	89/8.23	82/7.57	76/7.01	68/6.31
105.8/3.0	100/9.22	95/8.82	88/8.11	81/7.51	73/6.76
112.8/3.2	106/9.83	102/9.41	94/8.65	87/8.01	78/7.21
119.9/3.4	113/10.45	108/9.99	99/9.19	92/8.51	83/7.66
126.9/3.6	120/11.06	114/10.58	105/9.73	97/9.01	88/8.11
134/3.8	126/11.68	121/11.17	111/10.28	103/9.51	93/8.56
141.0/4.0	133/12.29	127/11.76	117/10.82	108/10.02	97/9.01
148.1/4.2	139/12.90	133/12.34	123/11.36	114/10.52	102/9.46
155.1/4.4	146/13.52	140/12.93	129/11.90	119/11.02	107/9.91
162.2/4.6	153/14.13	146/13.52	134/12.44	124/11.52	112/10.37
169.2/4.8	159/14.75	152/14.11	140/12.98	130/12.02	117/10.82
176.3/5.0	166/15.36	159/14.69	146/13.52	135/12.52	122/11.27
Area formula	<p>A_{min} is the required minimum room area in ft² /m²</p> <p>m_c is the actual refrigerant charge in the system in oz/kg</p> <p>m_{REL} is the refrigerant releasable charge in oz/kg (Applicable to the units with refrigerant sensors only)</p> <p>h_{inst} is the height of the bottom of the appliance relative to the floor of the room after installation.</p> <p>WARNING: The minimum room area or minimum room area of conditioned space is based on releasable charge and total system refrigerant charge.</p>				

1. **Installation** (where refrigerant pipes are allowed)

- Any person who is involved with working on a refrigerant circuit should hold a current valid certificate from an industry-accredited assessment authority, which authorizes their competence to handle refrigerants safely in accordance with an industry recognized assessment specification.
- Maintenance and repair requiring the assistance of licensed personnel shall be carried out under the supervision of the person competent in the use of flammable refrigerants.
- Protect refrigerant lines from physical damage.
- Ensure refrigerant lines comply with national refrigerant regulations.
- Mechanical connections shall be accessible for maintenance purposes.
- Be careful that foreign matter (oil, water, etc) does not enter the piping. Also, when storing the piping, securely seal the opening.
- Only licensed individuals should perform procedures that affect safety measures.
- Appliance shall be stored in a well ventilated area where the room size corresponds to the room area as specified for operation.
- Test joints with detection equipment, with the equipment both idle and operating, or under pressure matching these conditions after installation. DO NOT use detachable joints on the indoor side of the unit (use brazed or welded joints instead).
- In cases that require mechanical ventilation, ventilation openings shall be kept clear of obstruction.
- For units with refrigerant sensors: when the sensor detects a leak, the indoor unit will display an error code and emit a buzzing sound. The outdoor unit's compressor will immediately stop, and the indoor fan will start running. The refrigerant sensor has a 15-year service life. If it malfunctions, the indoor unit will display the error code "FHCC". The sensor cannot be repaired and must be replaced by the manufacturer with a specified sensor (this applies only to units with refrigerant sensors).

2. **When a FLAMMABLE REFRIGERANT is used**, the requirements for installation space of appliance and/or ventilation requirements are determined according to

- the mass charge amount(M) used in the appliance,
- the installation location,
- the type of ventilation of the location or of the appliance.
- piping material, pipe routing, and installation shall include protection from physical damage in operation and service, and be in compliance with national and local codes and standards, such as ASHRAE 15, IAPMO Uniform Mechanical Code, ICC International Mechanical Code, or CSA B52. All field joints shall be accessible for inspection prior to being covered or enclosed.
- the protection devices, piping, and fittings shall be protected as far as possible against adverse environmental effects, for example, the danger of water collecting and freezing in relief pipes or the accumulation of dirt and debris;
- the piping in refrigeration systems shall be so designed and installed to minimize the likelihood of hydraulic shock damaging the system;
- that precautions shall be taken to avoid excessive vibration or pulsation;
- the minimum floor area of the room shall be mentioned in the form of a table or a single figure without reference to a formula;
- after completion of field piping for split systems, the field pipework shall be pressure tested with an inert gas and then vacuum tested prior to refrigerant charging, according to the following requirements:

a. The minimum test pressure for the low side of the system shall be the low side

design pressure and the minimum test pressure for the high side of the system shall be the high side design pressure, unless the high side of the system cannot be isolated from the low side of the system in which case the entire system shall be pressure tested to the low side design pressure.

- b. The test pressure after removal of pressure source shall be maintained for at least 1 h with no decrease of pressure indicated by the test gauge, with test gauge resolution not exceeding 5% of the test pressure.
 - c. During the evacuation test, after achieving a vacuum level specified in the manual or less, the refrigeration system shall be isolated from the vacuum pump and the pressure shall not rise above 1500 microns within 10 min. The vacuum pressure level shall be specified in the manual, and shall be the lessor of 500 microns or the value required for compliance with national and local codes and standards, which may vary between residential, commercial, and industrial buildings.
- field-made refrigerant joints indoors shall be tightness tested according to the following requirements: The test method shall have a sensitivity of 5 grams per year of refrigerant or better under a pressure of at least 0.25 times the maximum allowable pressure. No leak shall be detected.

3 . Qualification of workers

Any maintenance, service and repair operations must be performed by qualified personnel. Every working procedure that affects safety means shall only be carried out by competent persons that joined the training and achieved competence should be documented by a certificate. The training of these procedures is carried out by national training organizations or manufacturers that are accredited to teach the relevant national competency standards that may be set in legislation. All training shall follow the ANNEX HH requirements of UL 60335-2-40 4th Edition.

Examples for such working procedures are:

- breaking into the refrigerating circuit;
- opening of sealed components;
- opening of ventilated enclosures.

4. Ventilated area

Ensure that the area is in the open or that it is adequately ventilated before breaking into the system or conducting any work. A degree of ventilation shall continue during the period that the work is carried out. The ventilation should safely disperse any released refrigerant and preferably expel it externally into the atmosphere.

5. Wiring

Check that wiring will not be subject to wear, corrosion, excessive pressure, vibration, sharp edges or any other adverse environmental effects. The check shall also take into account the effects of aging or continual vibration from sources such as compressors or fans.

6. Detection of flammable refrigerants

Under no circumstances shall potential sources of ignition be used in the searching for or detection of refrigerant leaks. A torch(or any other detector using a naked flame) shall not be used.

The following leak detection methods are deemed acceptable for refrigerant systems. Electronic leak detectors may be used to detect refrigerant leaks but, in the case of FLAMMABLE REFRIGERANTS, the sensitivity may not be adequate, or may need re-calibration. (Detection equipment shall be calibrated in a refrigerant-free area.) Ensure that the detector is not a potential source of ignition and is suitable for the refrigerant used. Leak detection equipment shall be set at a percentage of the LFL of the refrigerant and shall be calibrated to the refrigerant employed, and the appropriate percentage of gas (25% maximum) is confirmed. Leak detection fluids are also suitable for use with most refrigerants but the use of detergents containing chlorine shall be avoided as the chlorine may react with the refrigerant and corrode the copper lineset.

NOTE Examples of leak detection fluids are

- bubble method,
- fluorescent method agents.

If a leak is suspected, all naked flames shall be removed/extinguished.

If a leakage of refrigerant is found which requires brazing, all of the refrigerant shall be recovered from the system, or isolated (by means of shut off valves) in a part of the system remote from the leak. See the following instructions of removal of refrigerant.

7. Removal and evacuation

When breaking into the refrigerant circuit to make repairs - or for any other purpose conventional procedures shall be used. However, for flammable refrigerants it is important that best practice be followed, since flammability is a consideration.

The following procedure shall be adhered to:

- safely remove refrigerant following local and national regulations;
- evacuate;
- purge the circuit with inert gas (optional for A2L);
- evacuate (optional for A2L);
- continuously flush or purge with inert gas when using flame to open circuit; and
- open the circuit

The refrigerant charge shall be recovered into the correct recovery cylinders if venting is not allowed by local and national codes. For appliances containing flammable refrigerants, the system shall be purged with oxygen-free nitrogen to render the appliance safe for flammable refrigerants. This process might need to be repeated several times. Compressed air or oxygen shall not be used for purging refrigerant systems.

For appliances containing flammable refrigerants, refrigerants purging shall be achieved by breaking the vacuum in the system with oxygen-free nitrogen and continuing to fill until the working pressure is achieved, then venting to atmosphere, and finally pulling down to a vacuum (optional for A2L). This process shall be repeated until no refrigerant is within the system (optional for A2L). When the final oxygen-free nitrogen charge is used, the system shall be vented down to atmospheric pressure to enable work to take place.

The outlet for the vacuum pump shall not be close to any potential ignition sources, and ventilation must be available.

8. Charging procedures

In addition to conventional charging procedures, the following requirements shall be followed:





- Work shall be undertaken with appropriate tools only (In case of uncertainty, please consult the manufacturer of the tools for use with flammable refrigerants)
- Ensure that contamination of different refrigerants does not occur when using charging equipment. Hoses or lines shall be as short as possible to minimize the amount of refrigerant contained in them.
- Cylinders shall be kept upright.
- Ensure that the refrigeration system is grounded prior to charging the system with refrigerant.
- Label the system when charging is complete (if not already).
- Extreme care shall be taken not to overfill the refrigeration system.
- Prior to recharging the system it shall be pressure tested with oxygen free nitrogen (OFN). The system shall be leak tested on completion of charging but prior to commissioning. A follow up leak test shall be carried out prior to leaving the site.

9. Recovery

When removing refrigerant from a system, either for servicing or decommissioning, it is recommended good practice that all refrigerants are removed safely.

When transferring refrigerant into cylinders, ensure that only appropriate refrigerant recovery cylinders are used. Ensure that the correct number of cylinders for holding the total system charge is available. All cylinders used are designated.

Explanation of symbols displayed on the indoor unit or outdoor unit

	WARNING	<p>This symbol shows that this appliance used a flammable refrigerant. If the refrigerant is leaked and exposed to an external ignition source, there is a risk of fire.</p>
	CAUTION	<p>This symbol shows that the operation manual should be read carefully.</p>
	CAUTION	<p>This symbol shows that a licensed service professional should be handling this equipment with reference to the installation manual.</p>
	CAUTION	
	CAUTION	<p>This symbol shows that information is available such as the operating manual or installation manual.</p>

PRODUCT OVERVIEW

NOTE ON ILLUSTRATIONS:

Illustrations in this manual are for explanatory purposes. The actual shape of your indoor unit may be slightly different.

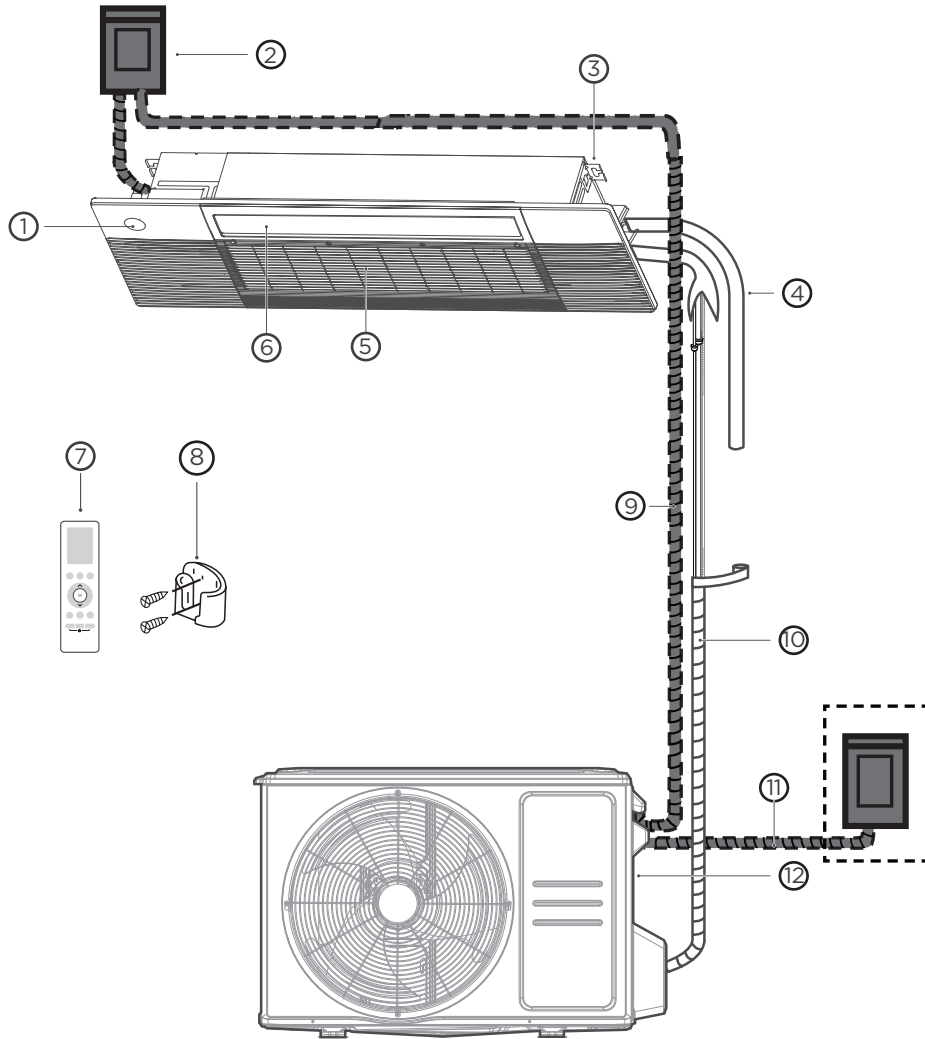











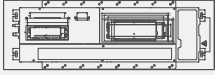

- | | | |
|------------------------------------|--|--|
| ① Display panel | ⑤ Air inlet (with air filter in it) | ⑨ Connection cable (purchase separately) |
| ② Circuit breaker | ⑥ Air outlet(Air flow louver) | ⑩ Refrigerant piping (purchase separately) |
| ③ Installation part | ⑦ Remote controller | ⑪ Outdoor unit power cable (purchase separately) |
| ④ Drain pipe (purchase separately) | ⑧ Remote controller Holder (purchase separately) | ⑫ Outdoor unit |

PRODUCT INSTALLATION

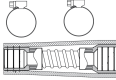
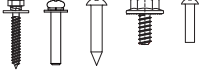
ACCESSORIES

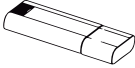
The air conditioning system comes with the following accessories. Use all of the installation parts and accessories to install the air conditioner. Improper installation may result in water leakage, electrical shock and fire, or cause the equipment to fail. The items that are not included with the air conditioner must be purchased separately.

Name of Accessories	Q'ty(pc)	Shape	Name of Accessories	Q'ty(pc)	Shape
Manual	1		Water receiver	1	
Installation cardboard template	1		Rubber ring	1	
Remote controller	1		AAA Battery	2	
Cable tie	6		Copper nut	2	
Drainpipe adaptor	1		Screw kits (ST8*50, M4*22, ST3.9*16, ST4.8*12, ST3.9*10)	1 (8,8,2,2,3)	
Panel	1		Wired controller (purchase separately)	1	
Smart kit (purchase separately)	1		Remote controller holder(purchase separately)	1	

Name	Model	Pipe specification		Remark
		Liquid Side	Gas Side	
Connecting pipe assembly	6K	Φ1/4in(Φ 6.35mm)	Φ3/8in(Φ9.52mm)	Pipes are not included in the accessories and you need to purchase it separately from the local dealer.
	9K	Φ1/4in(Φ 6.35mm)	Φ3/8in(Φ9.52mm)	
	12K	Φ1/4in(Φ 6.35mm)	Φ3/8in(Φ9.52mm)	
	18K	Φ1/4in(Φ 6.35mm)	Φ1/2in(Φ12.7mm)	

NOTE

Panel installation should be performed after wiring and piping have been completed.

Install Your Indoor Unit

1

Select installation location

NOTE

Before installing the indoor unit, you must choose an appropriate location. The following are standards that will help you choose an appropriate location for the unit.

Before Installation:

- Determine the route to move the unit to the installation site.
- First unseal and unpack the unit. Then, hold the seats of the hanger (4 pcs) to move the unit. Refrain from exerting force on other parts of the unit, especially the refrigerant piping, water discharge piping, and the plastic parts.

Proper installation locations meet the following standards:



Enough room exists for installation and maintenance.

Enough room exists for the connecting the pipe and drainpipe.



There is no direct radiation from heaters.

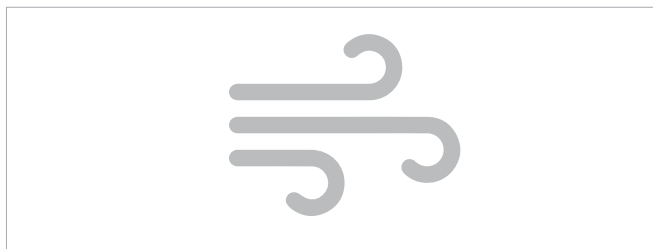

The air inlet and outlet are not blocked.

The airflow can fill the entire room.

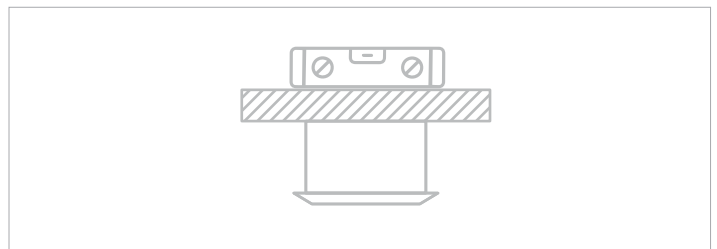

The ceiling is horizontal and its structure can sustain the weight of the indoor unit.

DO NOT install unit in the following locations:

- ⊘ Areas with oil drilling or fracking
- ⊘ Coastal areas with high salt content in the air
- ⊘ Areas with caustic gases in the air, such as hot springs
- ⊘ Areas that experience power fluctuations, such as factories
- ⊘ Enclosed spaces, such as cabinets
- ⊘ Kitchens that use natural gas
- ⊘ Areas with strong electromagnetic waves
- ⊘ Areas that store flammable materials or gas
- ⊘ Rooms with high humidity, such as bathrooms or laundry rooms

2

Confirm various sizes

Installation place

(unit: inch/mm)

Perspective A

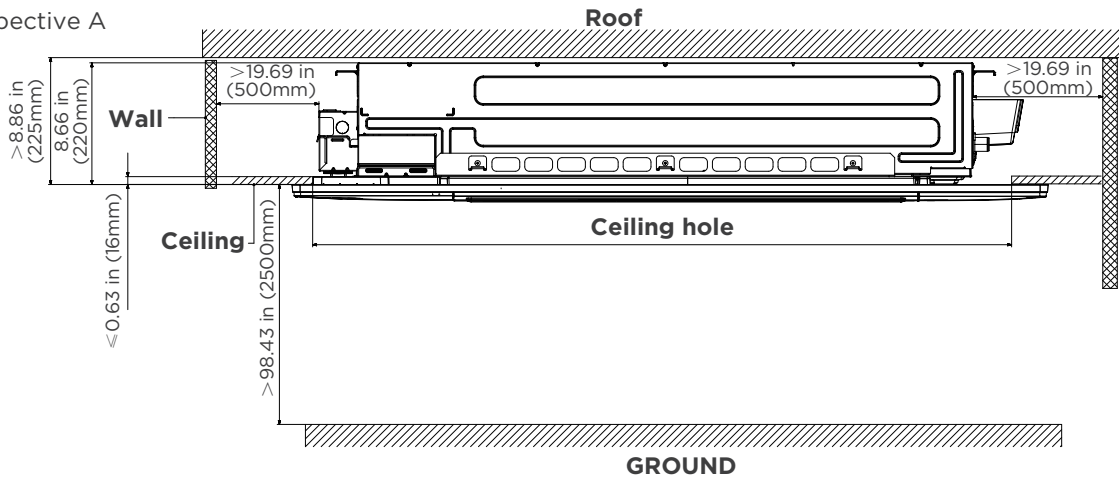

Perspective B

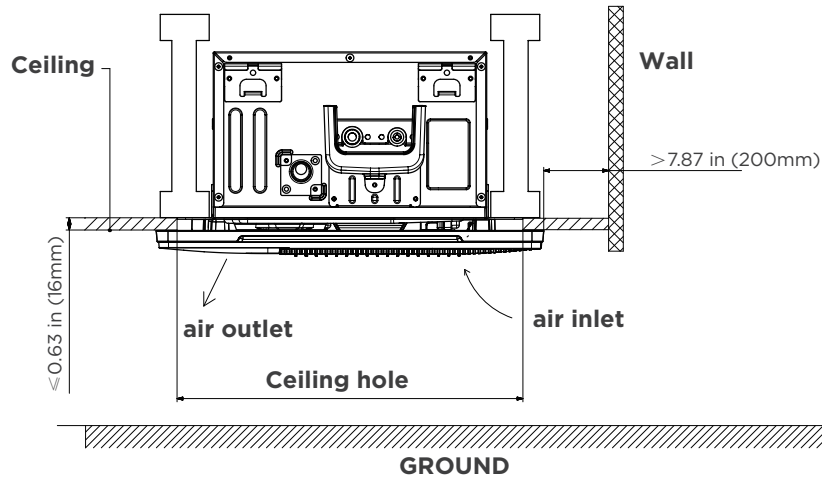

Indoor parts installation size

(unit: inch/mm)

Perspective A

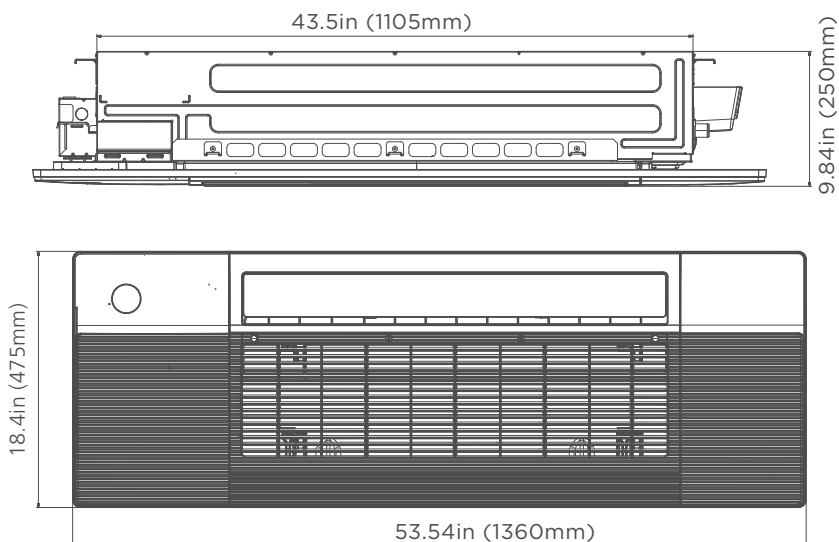

Perspective B

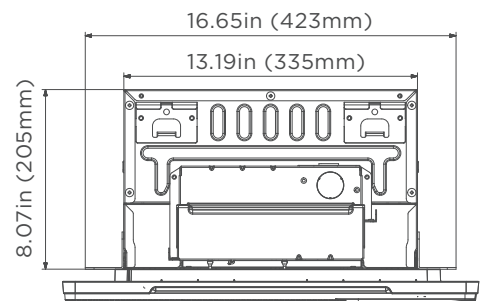

3

Indoor Unit Installation

Make sure that only specified components are used for the installation works.

Model A: with circuit breaker

- Remove the four screws to open the indoor control box and circuit breaker box.

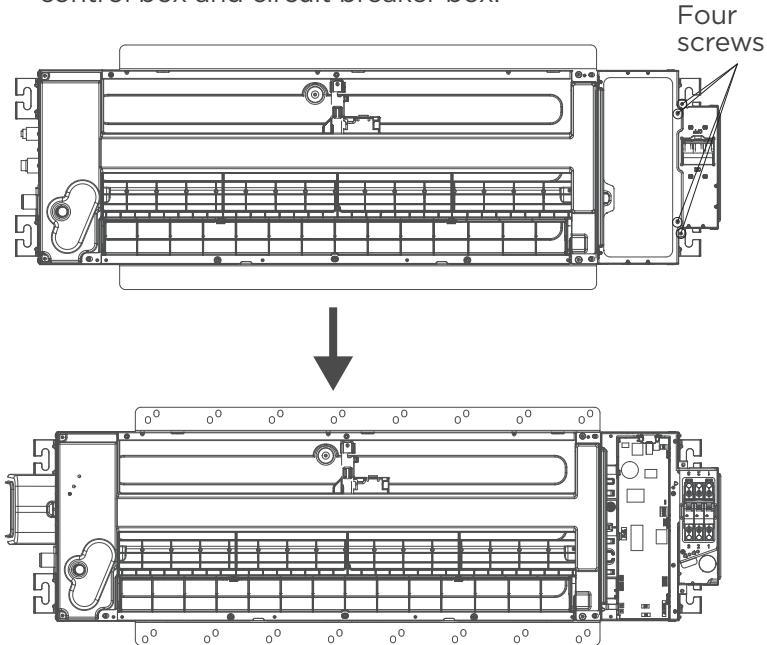

- Connect the wire to the air breaker according to the wire connecting diagram.

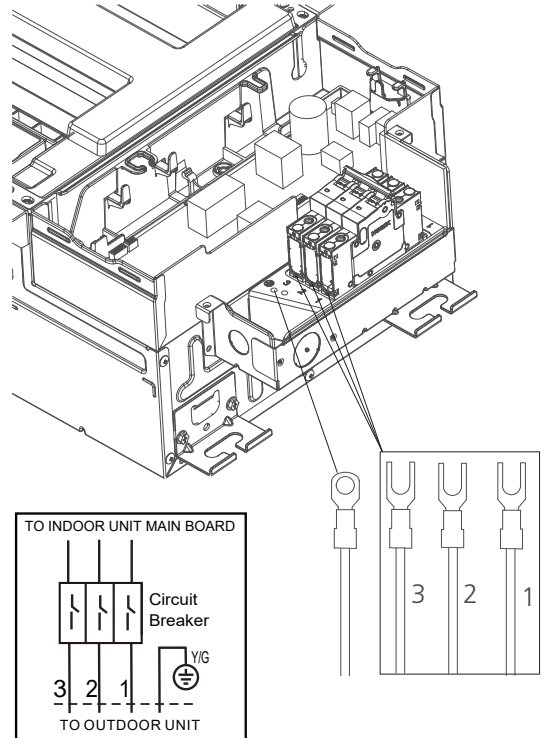

- Remove the pre-cutting cover on the circuit breaker box.

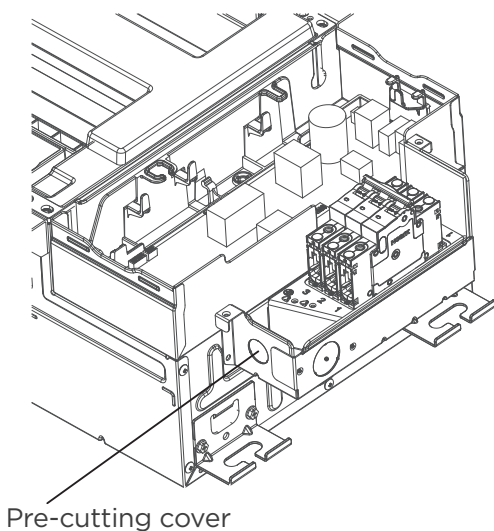

⚠ WARNING

The ground wire should be tightened firmly without loosening.

- Fasten and fix the wire body with a tie.

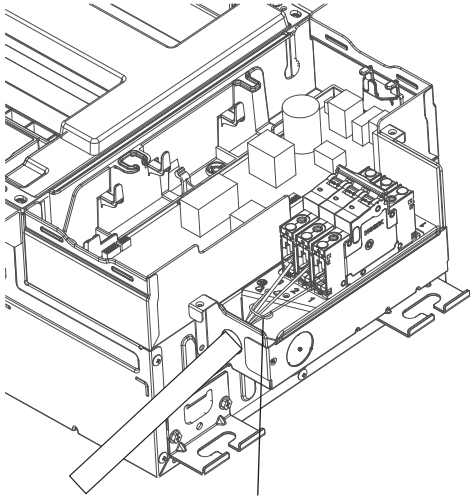

Fasten and fix the wire body with a tie

- Install the circuit breaker cover by fixing the two screws.

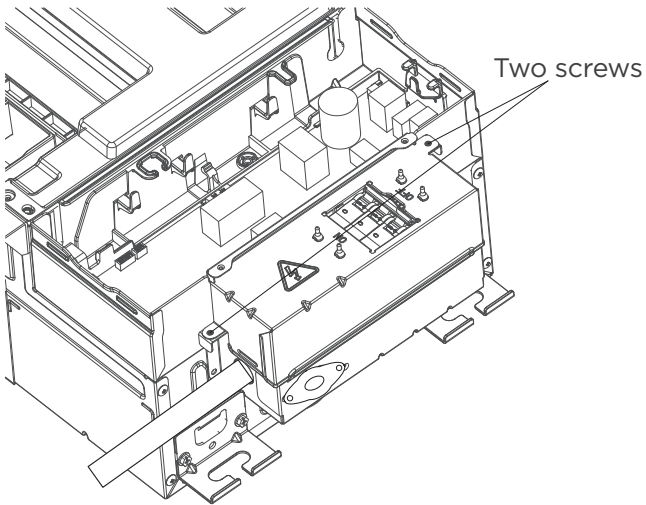

Two screws

Model B: with terminal

- Remove the four screws to open the indoor control box and terminal box.

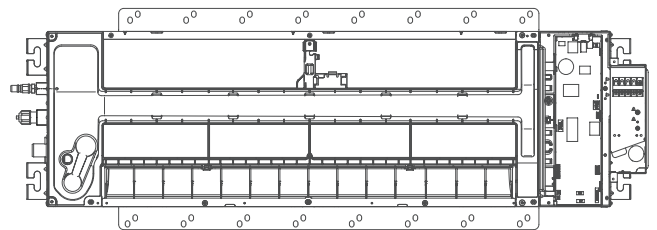
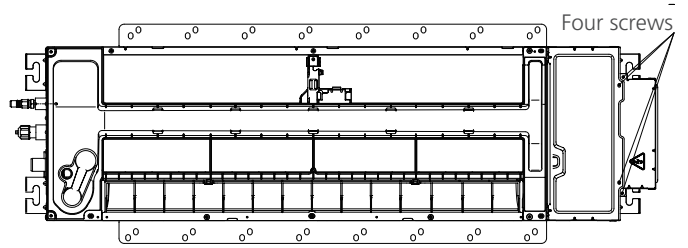

- Remove the pre-cutting cover on the terminal box. Remove the two screws, then take out the clip.

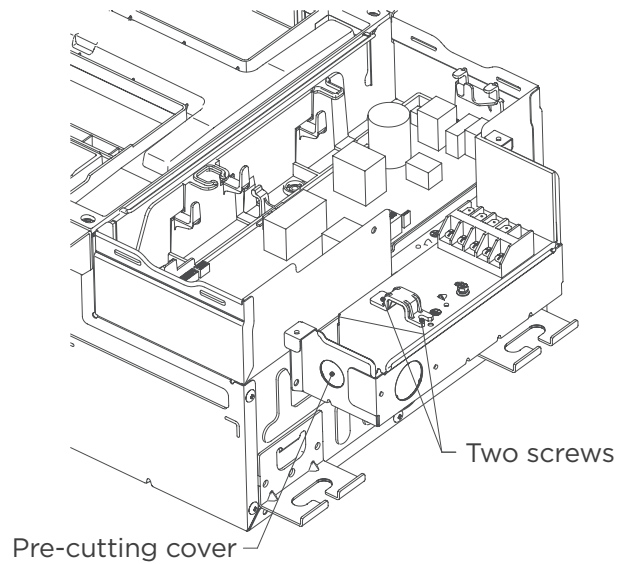

Two screws

Pre-cutting cover

- Connect the wire to the terminal according to the wire connecting diagram.

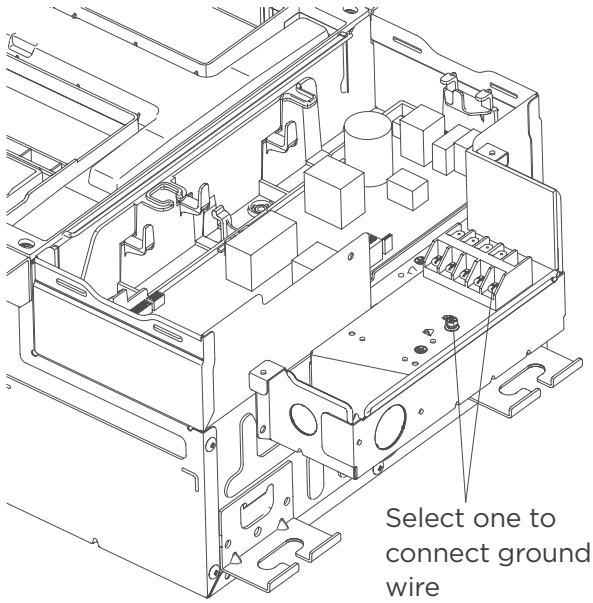

- Fix the wire with the clip by using the two screws.

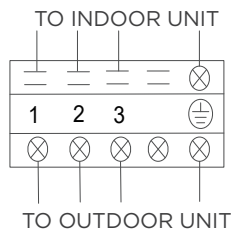
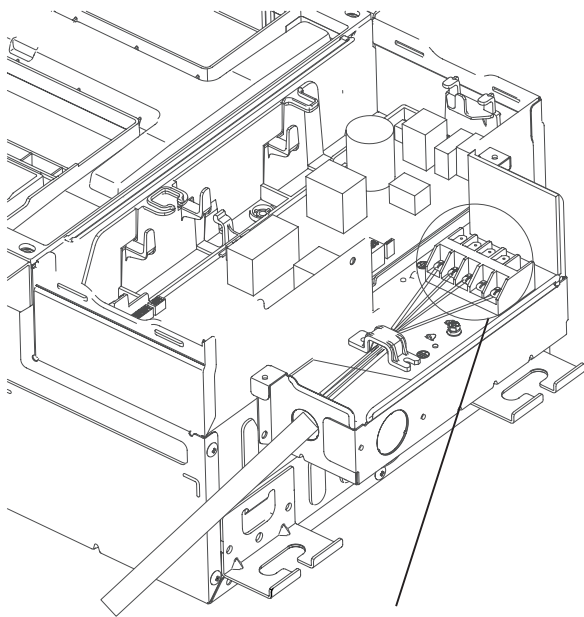

- Install the terminal cover by fixing the two screws.

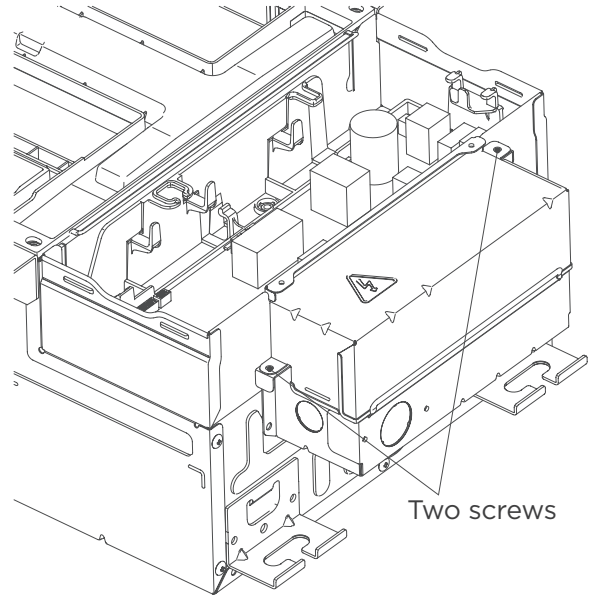

2. Install the indoor unit

NOTE:

After you have finished installing the main body, when choosing where to start, determine the direction of the pipes to be drawn out. Especially in cases where there is a ceiling involved, align the refrigerant pipes, drain pipes, and indoor and outdoor lines with their connection points before mounting the unit.

- After you selecting an installation location, drill a hole with the diameter of 6mm or less into the roof beam based on the layout of the installation board (accessory Installation cardboard template). After drilling the hole, remove the installation board.

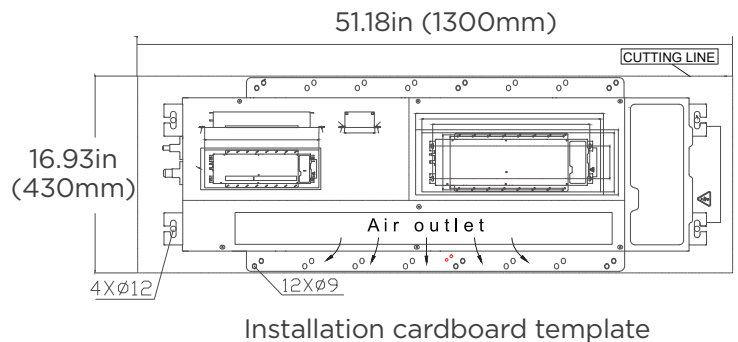

- Connecting the wire from the control box.

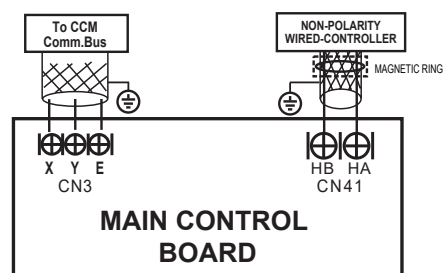

- Connecting the other side of the connecting cable to the wired controller.

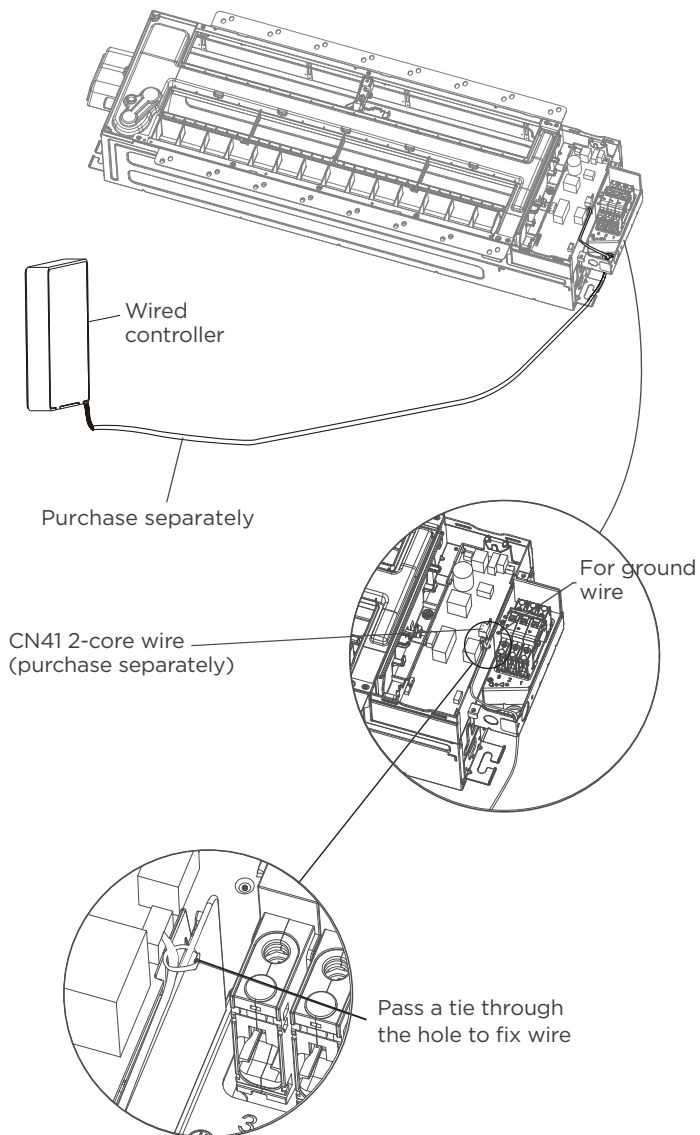

⚠ WARNING

Please follow local regulations and take measures to isolate high voltage and low voltage.

NOTE:

Be sure to reserve a length of the connecting wire for periodic maintenance. If there is a connection lug at the end of shielded wire, the connection lug should be properly grounded.

Install Your Outdoor Unit

1 Select installation location

NOTE : PRIOR TO INSTALLATION

Before installing the outdoor unit, you must choose an appropriate location. The following are standards that will help you choose an appropriate location for the unit.

Proper installation locations meet the following standards:

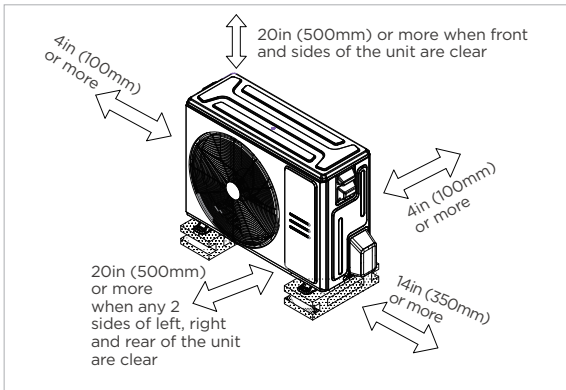

✓ Good air circulation and ventilation.



✓ Firm and solid—the location can support the unit and will not vibrate.



✓ Noise from the unit will not disturb other people.



✓ Protected from prolonged periods of direct sunlight or rain.



✓ Where snowfall is anticipated, take appropriate measures to prevent ice buildup and coil damage.

✓ Meets all spatial requirements shown in Installation Clearance Requirements above.

NOTE Install the unit by following local codes and regulations, there may be differ slightly between different regions.

CAUTION:

SPECIAL CONSIDERATIONS FOR EXTREME WEATHER

If the unit is exposed to heavy wind:

Install unit so that air outlet fan is at a 90° angle to the direction of the wind. If needed, build a barrier in front of the unit to protect it from extremely heavy winds. See Figures below.

If the unit is frequently exposed to heavy rain or snow:

Build a shelter above the unit to protect it from the rain or snow. Be careful not to obstruct air flow around the unit.

If the unit is frequently exposed to salty air(seaside):

Use outdoor unit that is specially designed to resist corrosion.

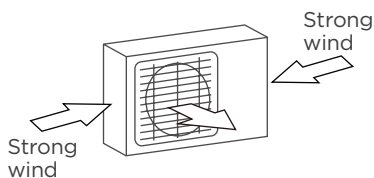

90° angle to the direction of the wind

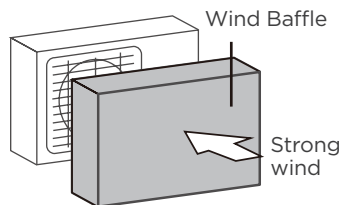

Build a wind Baffle to protect the unit

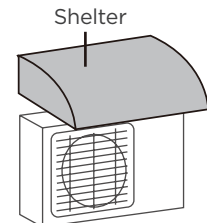

Build a shelter to protect the unit

DO NOT install unit in the following locations:

- ⊘ Near an obstacle that will block air inlets and outlets.
- ⊘ Near animals or plants that will be harmed by hot air discharge.
- ⊘ In a location that is exposed to large amounts of dust
- ⊘ Near a public street, crowded areas, or where noise from the unit will disturb others.
- ⊘ Near any source of combustible gas.
- ⊘ In a location exposed to a excessive amounts of salty air.

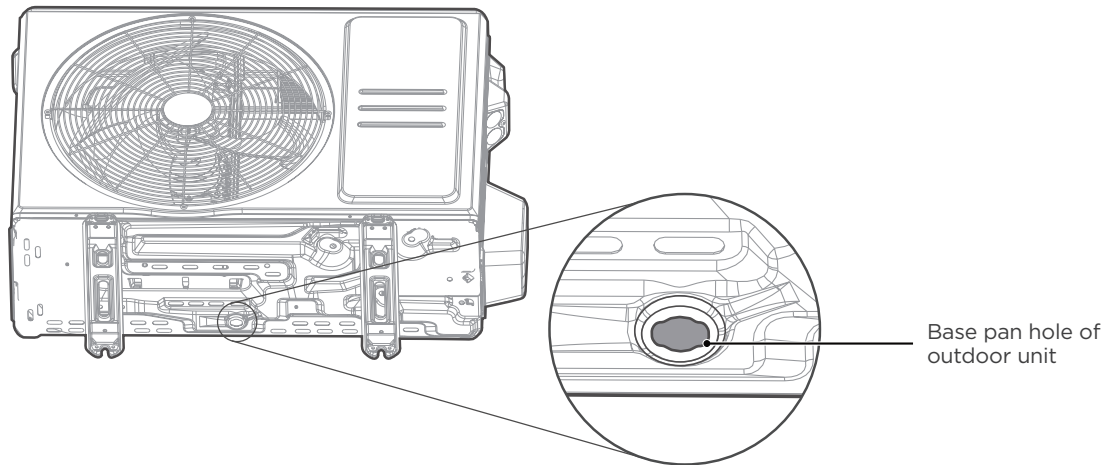
**Step 1:**

Find out the base pan hole of outdoor unit.

The design and specifications are subject to change without prior notice for product improvement. Consult with the sales agency or manufacturer for details. Any updates to the manual will be uploaded to the service website, please check for the latest version.

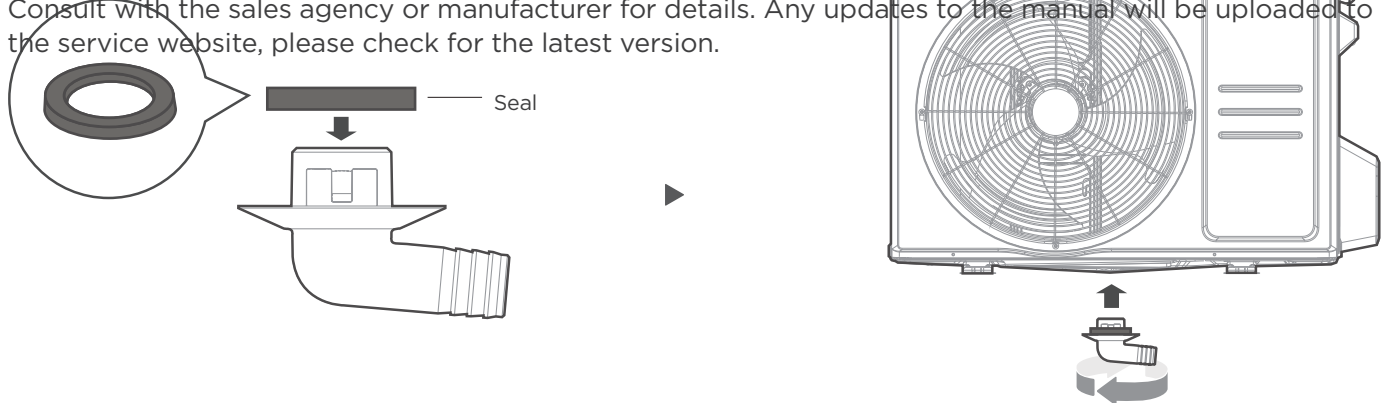
**Step 2:**

- Fit the rubber seal on the end of the drain joint that will connect to the outdoor unit.
- Insert the drain joint into the hole in the base pan of the unit. The drain joint will click in place.
- Connect a drain hose extension (not included) to the drain joint to redirect water from the unit during heating mode.

! IN COLD CLIMATES

QS002I-T2(B)-FKJ(R454B)

In cold climates, make sure that the drain hose is as vertical as possible to ensure swift water drainage. If water drains too slowly, it can freeze in the hose and flood the unit.

16122500A-3259.7

3

Anchor Outdoor Unit

⚠ WARNING

WHEN DRILLING INTO CONCRETE, EYE PROTECTION IS RECOMMENDED AT ALL TIME.

- The outdoor unit can be anchored to the ground or to a wall-mounted bracket with bolt(M10). Prepare the installation base of the unit according to the dimensions below.
- The following is a list of different outdoor unit sizes and the distance between their mounting feet. Prepare the installation base of the unit according to the dimensions below.

Outdoor Unit Types and Specifications (Split Type Outdoor Unit)

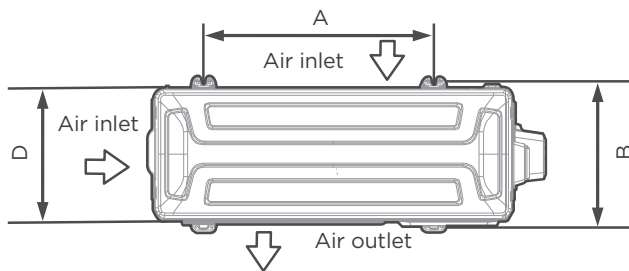

Top view

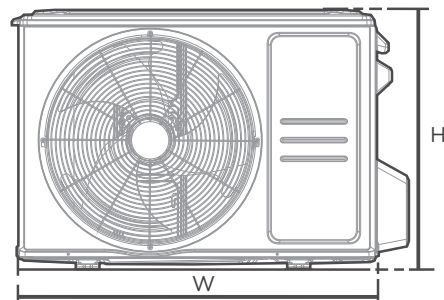

Front view

Outdoor Unit Dimensions W x H x D	Mounting Dimensions	
	Distance A	Distance B
30.1inx21.8inx11.9in (765mmx555mmx303mm)	17.8 in (452mm)	11.3 in (286mm)
31.7inx21.8inx12.9in (805mmx554mmx330mm)	20.1 in (511mm)	12.5 in (317mm)
35.0inx26.5inx13.5in (890mmx673mmx342mm)	26.1 in (663mm)	13.9 in (354mm)

Rows of series installation

The relations between H, A and L are as follows.

	L	A
L ≤ H	$L \leq 1/2H$	9.8in (25cm) or more
	$1/2H < L \leq H$	11.8in (30cm) or more
L > H	Can not be installed	

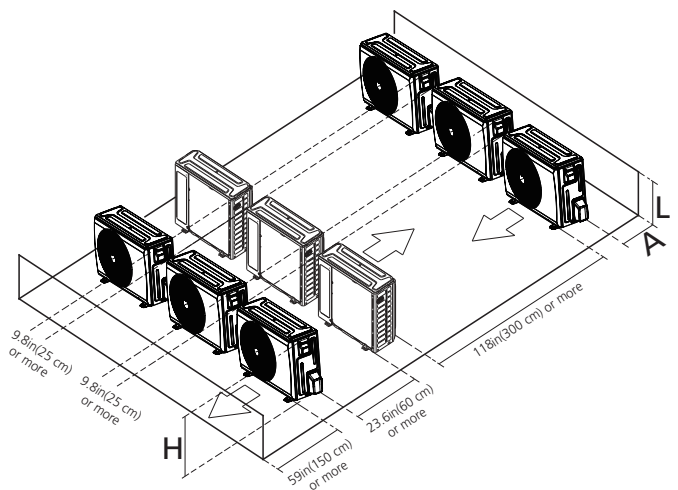

NOTE

H: Unit height

L: Height of the wall behind the unit

A: Distance between unit and wall

If you are installing the outdoor unit on the ground, or a concrete mounting platform, use the following steps:

1. Mark the positions for four expansion bolts based on dimensions in the Mounting Dimensions chart and illustrations above.
2. Pre-drill holes for expansion bolts.
3. Clean concrete dust away from the holes.
4. Place a nut on the end of each expansion bolt.
5. Hammer expansion bolts into the pre-drilled holes.
6. Remove the nuts from the expansion bolts, and place outdoor unit on bolts.
7. Put a washer on each of the expansion bolts, then reinstall the nuts.
8. Using a wrench, tighten each nut until snug.

 WARNING

WHEN DRILLING INTO CONCRETE, EYE PROTECTION IS RECOMMENDED AT ALL TIMES.

If you are installing the unit on a wall-mounted bracket, follow these steps:

 CAUTION:

Before installing a wall-mounted unit, make sure that the wall is made of solid brick, concrete, or a similarly strong material. The wall must be able to support at least 4 times the weight of the unit.

1. Mark the position of the bracket holes based on the dimensions in the Mounting Dimensions chart on the previous page.
2. Pre-drill the holes for the expansion bolts.
3. Clean dust and debris away from the holes.
4. Place a washer and nut on the end of each expansion bolt.
5. Thread expansion bolts through the holes in the mounting brackets. Then, put the mounting brackets in position and hammer the expansion bolts into the wall.
6. Check that the mounting brackets are level.
7. If the feet of the outdoor unit have rubber pads already installed, and you are using a local dealer's wall-mounting bracket, remove them before attempting to mount the condenser to the bracket. The mounting bracket has rubber isolating pads on it that will take the place of these.
8. Carefully lift the unit and place its mounting feet on the brackets.
9. Then, bolt the unit firmly to the brackets.

TO REDUCE VIBRATION OF WALL-MOUNTED UNIT

If allowed, you can install the wall-mounted unit with rubber gaskets to reduce vibration and noise.

Drainpipe Installation

The drainpipe is used to drain water away from the unit. Improper installation may cause unit and property damage.

⚠ CAUTION:

Before installing a wall-mounted unit, make sure that the wall is made of solid brick, concrete, or a similarly strong material. The wall must be able to support at least 4 times the weight of the unit.

- Insulate all piping to prevent condensation, which could lead to water damage.
- If the drainpipe is bent or installed incorrectly, water may leak and cause a water-level switch malfunction.
- In HEAT mode, the outdoor unit will discharge water. Ensure that the drain hose is placed in an appropriate area to avoid water damage and slippage.
- DO NOT pull the drainpipe forcefully. This could disconnect it.
- Drainpipe installation should comply with all local and national codes and regulations.

NOTE ON PURCHASING PIPES

Installation requires $\frac{3}{4}$ in PVC pipe, which can be obtained at your local hardware store or dealer.

Indoor Drainpipe Installation

Install the drainpipe as illustrated in the following Figure. Connect drainpipe to the indoor unit via drain adaptor.

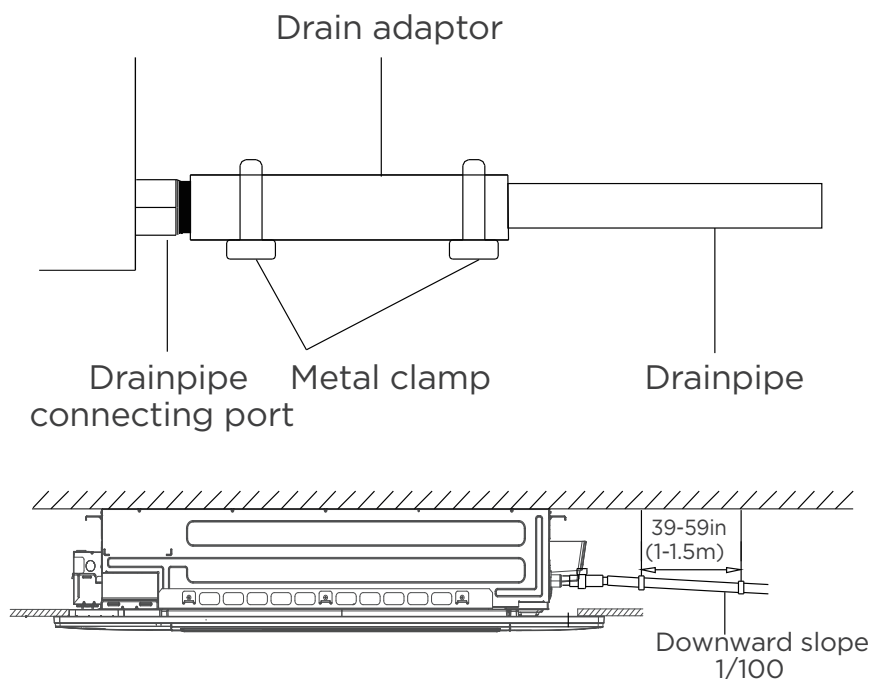

NOTE ON DRAINPIPE INSTALLATION

- When using an extended drainpipe, tighten the indoor connection with an additional protection tube to prevent it from pulling loose.
- The drainpipe should slope downward at a gradient of at least 1/100 to prevent water from flowing back into the air conditioner.

- To prevent the pipe from sagging, space hanging wires every 39-59in (1-1.5m).
- If the outlet of the drainpipe is higher than the body's pump joint, provide a lift pipe for the exhaust outlet of the indoor unit. The lift pipe must be installed no higher than 20.8in (53cm) from the drain port on the cassette and the distance between the unit and the lift pipe must be less than 11.8in (30cm). Incorrect installation could cause water to flow back into the unit and flood.
- To prevent air bubbles, keep the drain hose level or slightly tiled up (<3in/75mm).

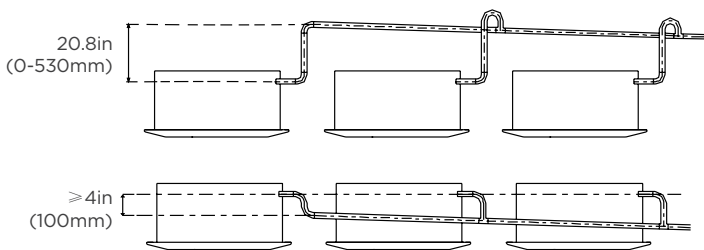
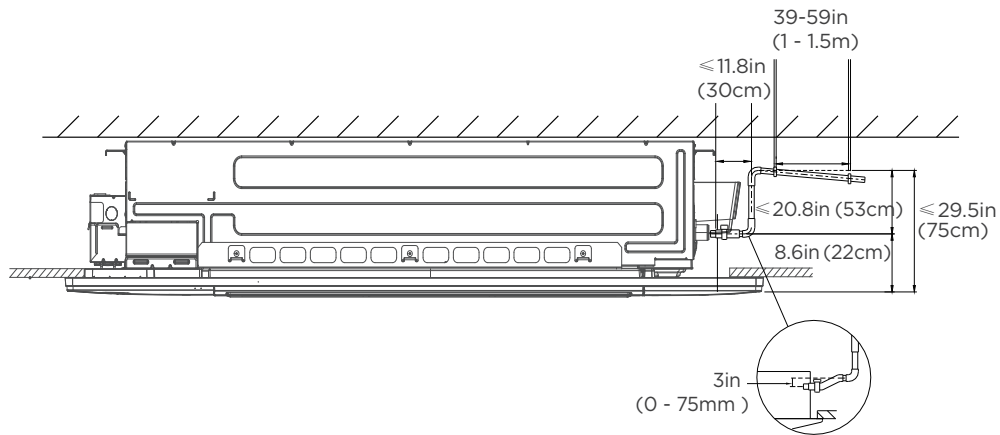

Pass the drain hose through the wall hole. Make sure the water drains to a safe location where it will not cause water damage or a slipping hazard.

NOTE

The drainpipe outlet should be at least 1.9in (50mm) above the ground. If it touches the ground, the unit may become blocked and malfunction. If you discharge the water directly into a sewer, make sure that the drain has a U or S pipe to catch odors that might otherwise come back into the house.

Drill wall hole

1. Using a 2.5in (65mm) or 3.54in (90mm) core drill, drill a hole in the wall. Make sure that the hole is drilled at a slight downward angle, so that the outdoor end of the hole is lower than the indoor end by about 0.2-0.275in (5mm-7mm). This will ensure proper water drainage.
2. Place the protective wall cuff in the hole. This protects the edges of the hole and will help seal it when you finish the installation process.

⚠ CAUTION:

When drilling the wall hole, make sure to avoid wires, plumbing, and other sensitive components.

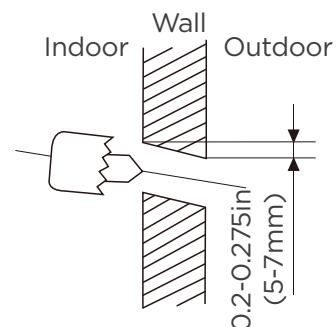

NOTE: When the gas side connective pipe is Φ 5/8in (16mm) or more, the wall hole should be 3.54in (90mm).

REFRIGERANT PIPING CONNECTION

When connecting refrigerant piping, **DO NOT** let substances or gases other than the specified refrigerant enter the unit. The presence of other gases or substances will lower the unit's capacity, and can cause abnormally high pressure in the refrigeration cycle. This can cause explosion and injury.

Notes on pipe length and elevation

The maximum length and drop height based on models.

Model	Length of piping	Maximum drop height
6K/9K/12K	82ft/25m	49.2ft/15m
18K	98.4ft/30m	65.6ft/20m

Ensure that the length of the refrigerant pipe, the number of bends, and the drop height between the indoor and outdoor units meets the requirements shown in the table next to it:

⚠ CAUTION

Oil traps

If oil flows back into the outdoor unit's compressor, this might cause liquid compression or deterioration of oil return. Oil traps in the rising gas piping can prevent this.

An oil trap should be installed every 20ft(6m) of vertical suction line riser (<36K). An oil trap should be installed every 32.8ft(10m) of vertical suction line riser (≥36K).

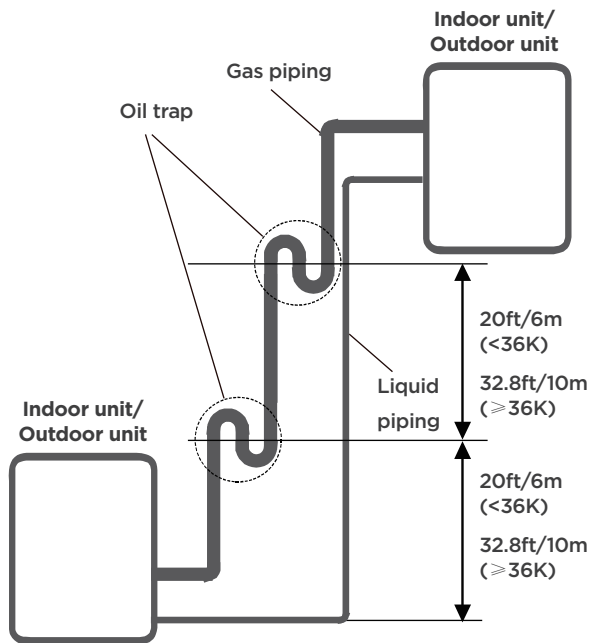

Connection Instructions—Refrigerant Piping

⚠ CAUTION

- The branching pipe must be installed horizontally. An angle of more than 10° may cause malfunction.
- **DO NOT** install the connecting pipe until both indoor and outdoor units have been installed.
- Insulate both the gas and liquid piping to prevent condensation.

Step 1: Cut pipes

When preparing refrigerant pipes, take extra care to cut and flare them properly. This will ensure efficient operation and minimize the need for future maintenance.

- Measure the distance between the indoor and outdoor units.
- Using a pipe cutter, cut the pipe a little longer than the measured distance.
- Make sure that the pipe is cut at a perfect 90° angle.

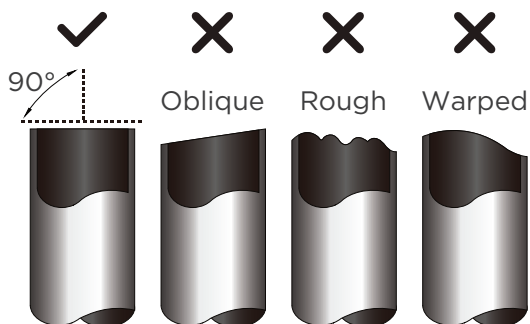

💡 DO NOT DEFORM PIPE WHILE CUTTING

Be extra careful not to damage, dent, or deform the pipe while cutting. This will drastically reduce the heating

Step 2: Remove burrs

Burrs can affect the air-tight seal of refrigerant piping connection. They must be completely removed.

- Hold the pipe at a downward angle to prevent burrs from falling into the pipe.
- Using a reamer or deburring tool, remove all burrs from the cut section of the pipe.

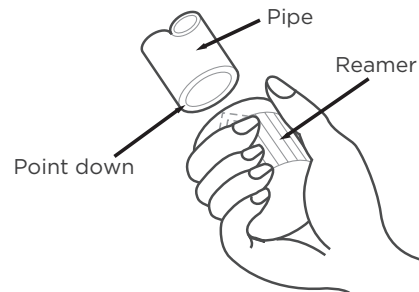

Step 3: Flare pipe ends

Proper flaring is essential to achieve an airtight seal.

- After removing burrs from cut pipe, seal the ends with PVC tape to prevent foreign materials from entering the pipe.
- Sheath the pipe with insulating material.
- Place flare nuts on both ends of pipe. Make sure they are facing in the right direction, because you can't put them on or change their direction after flaring.

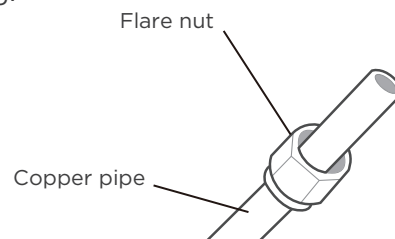

- Remove PVC tape from ends of pipe when ready to perform flaring work.
- Clamp flare form on the end of the pipe. The end of the pipe must extend beyond the flare form.

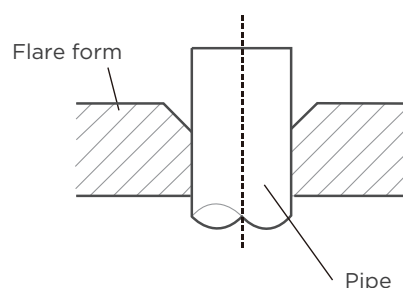

- Place flaring tool onto the form.
- Turn the handle of the flaring tool clockwise until the pipe is fully flared.

PIPING EXTENSION BEYOND FLARE FORM

Pipe gauge	Tightening torque	Flare dimension(A)	Flare shape
Ø1/4in Ø6.35mm	18-20 N.m (180-200kgf.cm)	0.33~0.34in (8.4~8.7mm)	
Ø3/8in Ø9.52mm	32-39 N.m (320-390kgf.cm)	0.52~0.53in (13.2~13.5mm)	
Ø1/2in Ø12.7mm	49-59 N.m (490-590kgf.cm)	0.64~0.65in (16.2~16.5mm)	

- Remove the flaring tool and flare form, then inspect the end of the pipe for cracks and even flaring.

Step 4: Connect pipes

Connect the copper pipes to the indoor unit first, then connect it to the outdoor unit. You should first connect the low-pressure pipe, then the high pressure pipe.

- When connecting the flare nuts, apply a thin coat of refrigeration oil to the flared ends of the pipes.
- Align the center of the two pipes that you will connect.

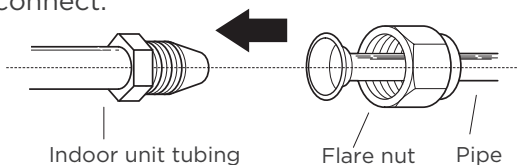

- Tighten the flare nut snugly by hand.
- Using a wrench, grip the nut on the unit tubing.
- While firmly gripping the nut, use a torque wrench to tighten the flare nut according to the torque values in above table.

NOTE

Use both a spanner and a torque wrench when connecting or disconnecting pipes to/from the unit.

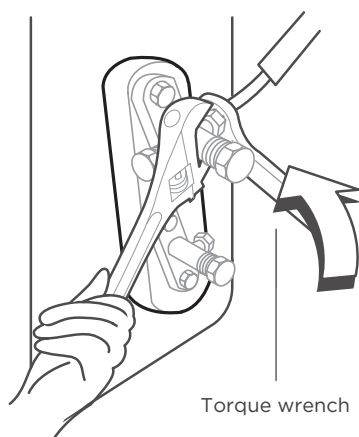

CAUTION

Ensure to wrap insulation around the piping. Direct contact with the bare piping may result in burns or frostbite.

- Make sure the pipe is properly connected. Over tightening may damage the bell mouth and under tightening may lead to leakage.

NOTE MINIMUM BEND RADIUS

Carefully bend the tubing in the middle according to the diagram below.

DO NOT bend the tubing more than 90° or more than 3 times.

Use appropriate tool

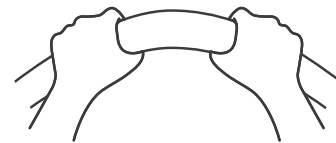

min-radius 3.9in (100mm)

- After connecting the copper pipes to the indoor unit, wrap the power cable, signal cable and the piping together with binding tape.

NOTE

DO NOT intertwine signal cable with other wires. While bundling these items together. **DO NOT** intertwine or cross the signal cable with any other wiring.

- Thread this pipeline through the wall and connect it to the outdoor unit.
- Insulate all the piping, including the valves of the outdoor unit.
- Fix the water receiver (supplied in Accessories box) to the indoor unit by a screw.

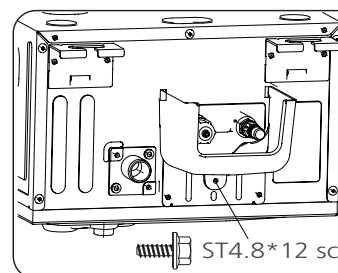

NOTE: Two ST4.8*12 screws are supplied, one of which is spare.

ST4.8*12 screw

- Open the stop valves of the outdoor unit to start the flow of the refrigerant between the indoor and outdoor unit.

CAUTION

Check to make sure there is no refrigerant leak after completing the installation work. If there is a refrigerant leak, ventilate the area immediately and evacuate the system. (refer to the Air Evacuation section of this manual)

WIRING PRECAUTIONS

⚠ WARNING

BEFORE PERFORMING ANY ELECTRICAL WORK, READ THESE WARNINGS.

- All wiring must comply with local and national electrical codes, regulations and must be installed by a licensed electrician.
- All electrical connections must be made according to the Electrical Connection Diagram located on the panels of the indoor and outdoor units.
- If there is a serious safety issue with the power supply, stop work immediately. Explain your reasoning to the client, and refuse to install the unit until the safety issue is properly resolved.
- Power voltage should be within 90-110% of rated voltage. Insufficient power supply can cause malfunction, electrical shock, or fire.
- Installation of an external surge suppressor at the outdoor disconnect is recommended.
- If connecting power to fixed wiring, a switch or circuit breaker that disconnects all poles and has a contact separation of at least 1/8in (3mm) must be incorporated in the fixed wiring. The qualified technician must use an approved circuit breaker or switch.
- Only connect the unit to an individual branch circuit. Do not connect another appliance to that outlet.
- Make sure to properly ground the air conditioner.
- Every wire must be firmly connected. Loose wiring can cause the terminal to overheat, resulting in product malfunction and possible fire.
- Do not let wires touch or rest against refrigerant tubing, the compressor, or any moving parts within the unit.
- If the unit has an auxiliary electric heater, it must be installed at least 40in (1 meter) away from any combustible materials.
- To avoid getting an electric shock, never touch the electrical components soon after the power supply has been turned off. After turning off the power, always wait 10 minutes or more before you touch the electrical components.
- Make sure that you do not cross your electrical wiring with your signal wiring.
- This may cause distortion, interference or possibly damage to circuit boards.
- No other equipment should be connected to the same power circuit.
- Connect the outdoor wires before connecting the indoor wires.

⚠ WARNING

BEFORE PERFORMING ANY ELECTRICAL OR WIRING WORK, TURN OFF THE MAIN POWER TO THE SYSTEM.

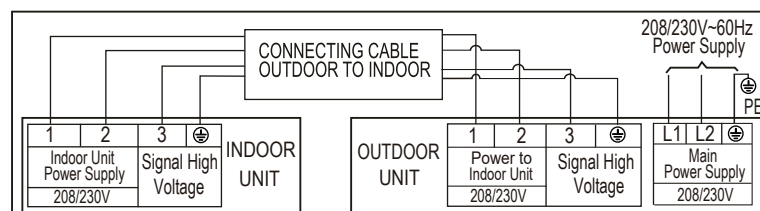

Connection Diagram (6K/9K/12K/18K)

NOTE ON CIRCUIT BREAKER

When the maximum current of the air conditioner is more than 16A, a circuit breaker or leakage protection switch with protective device shall be used (purchased separately). When the maximum current of the air conditioner is less than 16A, the power cord of air conditioner shall be equipped with plug (purchased separately). In North America, the appliance should be wired according to NEC and CEC requirements.

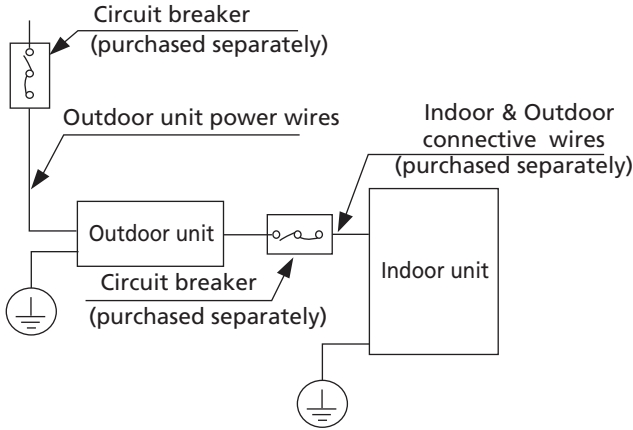

NOTE: The diagrams are for explanation purpose only. Your machine may be slightly different. The actual shape shall prevail.

OUTDOOR UNIT WIRING

⚠ WARNING

Before performing any electrical or wiring work, turn off the main power to the system.

1. Prepare the cable for connection
 - a. You must first choose the right cable size.
Choose the cable type according to the local electrical codes and regulations.
 - b. The size of the power supply cable, signal cable, fuse, and switch needed is determined by the Minimum Circuit Ampacity of the unit.
The Minimum Circuit Ampacity is indicated on the nameplate located on the side panel of the unit. Refer to this nameplate to choose the right cable, fuse, or switch.
 - c. Using wire strippers, strip the rubber jacket from both ends of the signal cable to reveal approximately 5.9in (150mm) of wire.
 - d. Strip the insulation from the ends.

NOTE: When connecting the wires, strictly follow the wiring diagram found inside the electrical box cover.

2. Remove the electric cover of the outdoor unit. If there is no cover on the outdoor unit, take off the bolts from the maintenance board and remove the protection board.

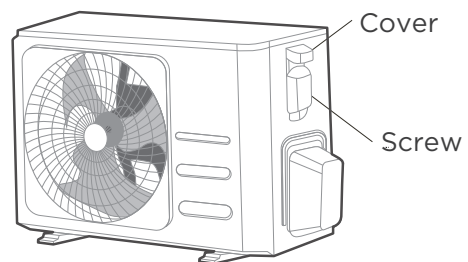

3. Connect the wires to the terminals
Match the wire colors/labels with the labels on the terminal block. Firmly screw each wire to its corresponding terminal.
4. Clamp down the cable with the cable clamp.
5. Insulate unused wires with electrical tape. Keep them away from any electrical or metal parts.
6. Reinstall the cover of the electric control box.

INDOOR UNIT WIRING

1. Prepare the cable for connection
 - a. Using wire strippers, strip the rubber jacket from both ends of the signal cable to reveal about 5.9in (150mm) of the wire.
 - b. Strip the insulation from the ends of the wires.
2. Open the front panel of the indoor unit.

Using a screwdriver, remove the cover of the electric control box on your indoor unit.

3. Thread the power cable and the signal cable through the wire outlet.

4. Connect the wires to the terminals.

Match the wire colors/labels with the labels on the terminal block. Firmly screw each wire to its corresponding terminal. Refer to the Serial Number and Wiring Diagram located on the cover of the electric control box.

CAUTION

- While connecting the wires, please strictly follow the wiring diagram.
- The refrigerant circuit can become very hot. Keep the interconnection cable away from the copper tube.

5. Clamp down the cable with the cable clamp. The cable must not be loose or pull on the wires.
6. Reattach the electric box cover.

AIR EVACUATION

NOTICE

When opening valve stems, turn the hexagonal wrench until it hits against the stopper. Do not try to force the valve to open further.

Preparations and precautions

Air and foreign matter in the refrigerant circuit can cause abnormal rises in pressure, which can damage the air conditioner, reduce its efficiency, and cause injury. Use a vacuum pump and manifold gauge to evacuate the refrigerant circuit, removing any non-condensable gas and moisture from the system. Evacuation should be performed upon initial installation and when unit is relocated.

BEFORE PERFORMING EVACUATION

- ✓ Check to make sure the connective pipes between the indoor and outdoor units are connected properly.
- ✓ Check to make sure all wiring is connected properly.

Evacuation Instructions

1. Connect the charge hose of the manifold gauge to service port on the outdoor unit's low pressure valve.
2. Connect another charge hose from the manifold gauge to the vacuum pump.
3. Open the Low Pressure side of the manifold gauge. Keep the High Pressure side closed.
4. Turn on the vacuum pump to evacuate the system.
5. Run the vacuum for at least 15 minutes, or until the Compound Meter reads -76cmHg (-10^5Pa).

Outdoor unit

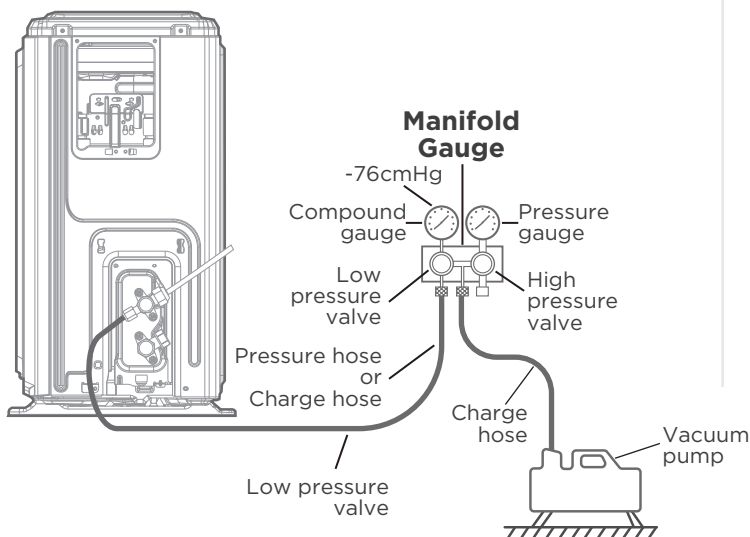

6. Close the Low Pressure side of the manifold gauge, and turn off the vacuum pump.
7. Wait for 5 minutes, then check that there has been no change in system pressure.
8. If there is a change in system pressure, refer to Gas Leak Check section for information on how to check for leaks. If there is no change in system pressure, unscrew the cap from the packed valve (high pressure valve).
9. Insert hexagonal wrench into the packed valve (high pressure valve) and open the valve by turning the wrench in a $1/4$ counterclockwise turn. Listen for gas to exit the system, then close the valve after 5 seconds.
10. Watch the Pressure Gauge for one minute to make sure that there is no change in pressure. The Pressure Gauge should read slightly higher than atmospheric pressure.
11. Remove the charge hose from the service port.

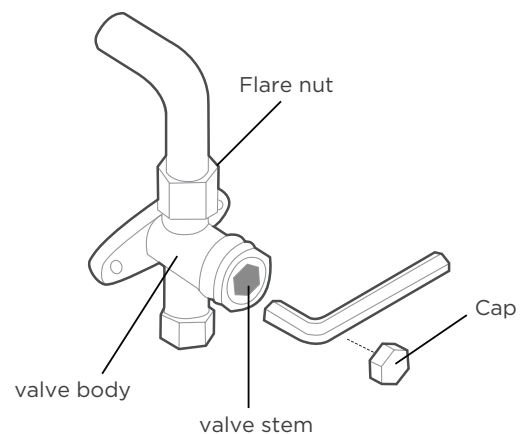

12. Using hexagonal wrench, fully open both the high pressure and low pressure valves.
13. Tighten valve caps on all three valves (service port, high pressure, low pressure) by hand. You may tighten it further using a torque wrench if needed.

NOTE ON ADDING REFRIGERANT

CAUTION

DO NOT mix refrigerant types.

Some systems require additional charging depending on pipe lengths. In North America, the standard pipe length is 25ft (7.5m). The refrigerant should be charged from the service port on the outdoor unit's low pressure valve. The additional refrigerant to be charged can be calculated using the following formula:

Refrigerant	Liquid Side Diameter		
	Ø1/4in (Ø6.35mm)	Ø3/8in (Ø9.52mm)	Ø1/2in (Ø12.7mm)
R454B	(Pipe length - standard length) x 0.16oz/ft (Pipe length - standard length) x 15g/m	(Pipe length - standard length) x 0.32oz/ft (Pipe length - standard length) x 30g/m	(Pipe length - standard length) x 0.69oz/ft (Pipe length - standard length) x 65g/m

ELECTRICAL AND GAS LEAK CHECKS

⚠ WARNING - RISK OF ELECTRICAL SHOCK

ALL WIRING MUST BE INSTALLED BY A LICENSED ELECTRICIAN AND COMPLY WITH LOCAL, STATE, AND NATIONAL ELECTRICAL CODES.

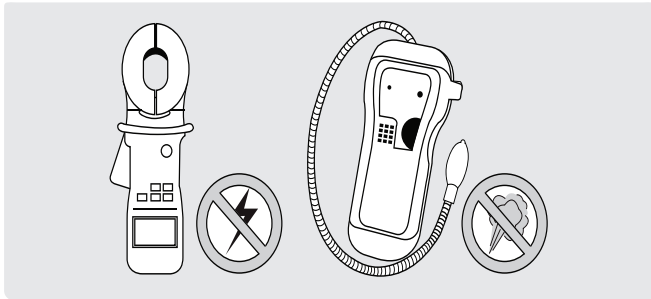

Electrical Safety Checks

After installation is complete, confirm that all electrical wiring has been installed in accordance with local and national regulations, and according to the installation manual.

BEFORE TEST RUN

Check Grounding Work

Measure grounding resistance by visual detection and with a grounding resistance tester. Grounding resistance must be less than 0.1 Ω .

NOTE: This may not be required for some locations in North America.

DURING TEST RUN

Check for Electrical Leakage

During the Test Run, use an electroprobe and multimeter to perform a comprehensive electrical leakage test.

IF ELECTRICAL LEAKAGE IS DETECTED

If electrical leakage is detected, turn off the unit immediately and call a licensed electrician to find and resolve the cause of the leakage.

NOTE: This may not be required for some locations in North America.

Gas Leak Checks

There are two different methods to check for gaseous leaks. Use Fig. 8.1 below as a guide for the critical points to check for leaks.

Soap and Water Method

Using a soft brush or spray bottle, apply a soapy water solution to all of the pipe connection points of the indoor and outdoor units, watching to see if any bubbles form. The presence of bubbles indicates there is a leak.

Leak Detector Method

If using a leak detector, refer to the device's operation/instruction manual for proper usage instructions.

After performing GAS leak checks

After confirming that all of the refrigerant pipe connections points DO NOT leak, replace the valve cover on the outside unit and wrap and insulate the piping connections of the indoor unit.

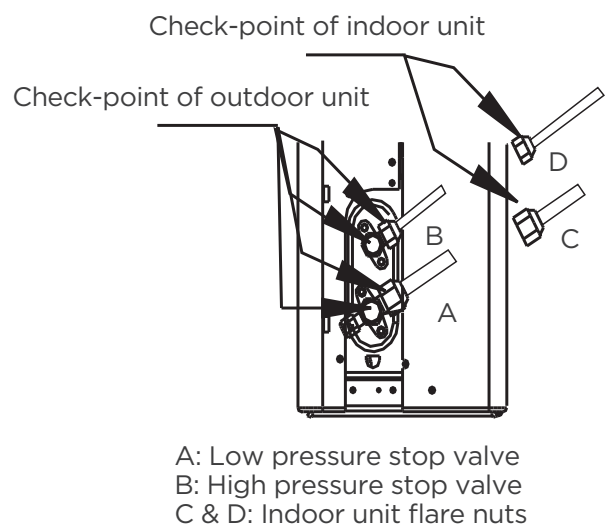

Fig. 8.1

PANEL INSTALLATION

Step1: Prepare and install ceiling

- Drill 16.93in x51.18in (430 mm x 1300 mm) hole into the ceiling based on the layout of the installation board.
The center of the ceiling opening should match the center of the body of the indoor unit.

NOTE:

In order to keep the ceiling level and prevent vibrations, reinforce the strength of the ceiling when necessary.

- Once the ceiling is cut, remove the installation board. then install the ceiling.

Step2: Panel Installation

Model A

NOTE:

The air grille received by the customer is not tightened by the wire rope, but is specially designed to be loose for easy installation.

- Grab air grille with your fingers and pull it out slowly in the direction of the arrow.

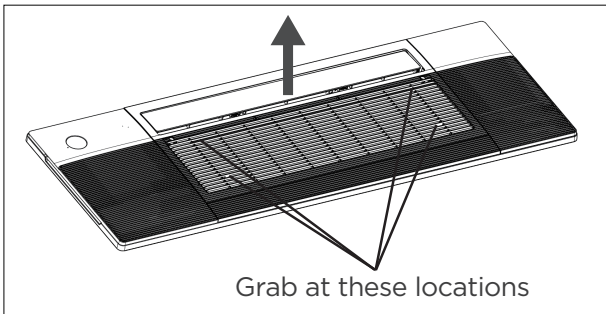

- Pull the panel grille out of the panel, fix the cassette panel to the one-way cassette by two plastic buckles.

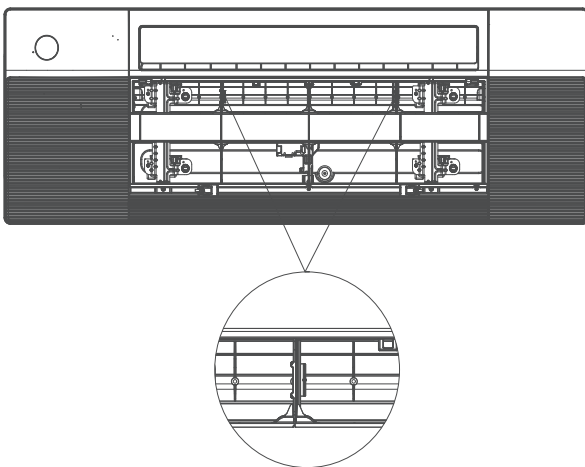

- Manually rotate the air deflector, fix the panel to the cassette by using 3×M4*22 screws and a ST3.9*16 screw.

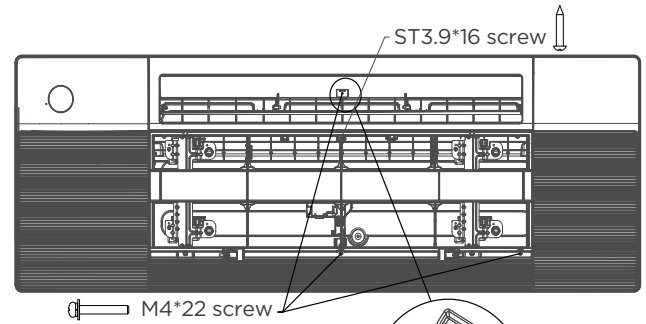

NOTE:

Eight M4*22 screws are supplied, two of which are spare. Two ST3.9*16 screws are supplied, one of which is spare.

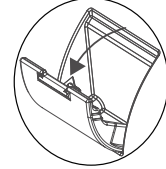

Before fixing this screw, you need to open the screw cover; and after fixing screw, please close the cover.

- Open the two covers on both sides of the panel, fix the panel to the cassette by using 3× M4*22 screws.

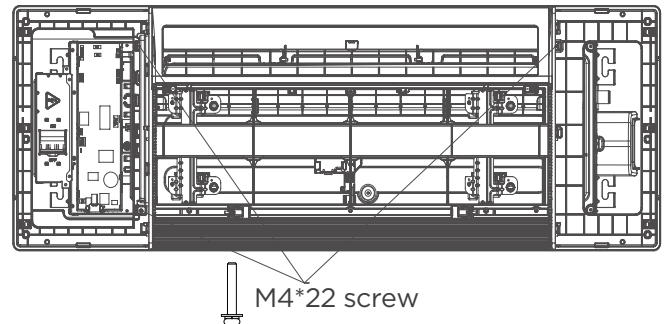

- Connect the display board to the main control board, up to four wires are required to connect.

NOTE:

The corresponding colors or corresponding pins are connected each other.

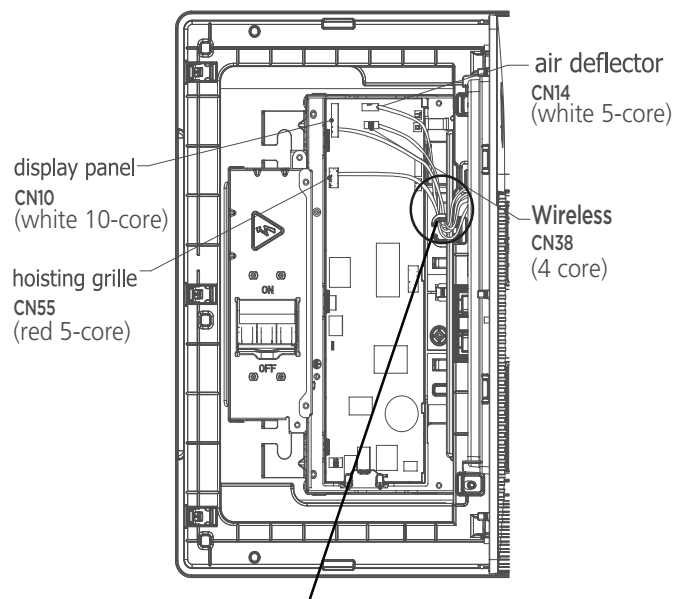

when connection is completed, please clip the wires to the buckle.

- Install the control box cover and turn the circuit breaker to ON, then close the two plastic covers on both sides of the panel.

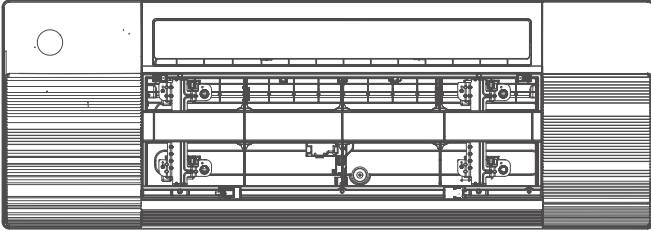
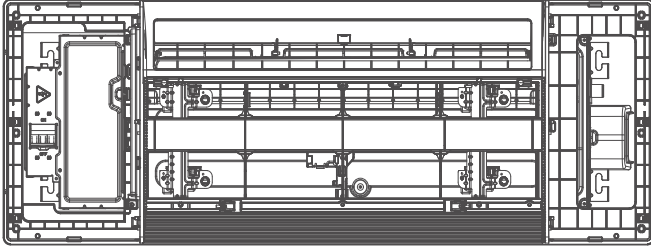

- During the test-run process, the display will be lighted and the air griller will rise automatically.

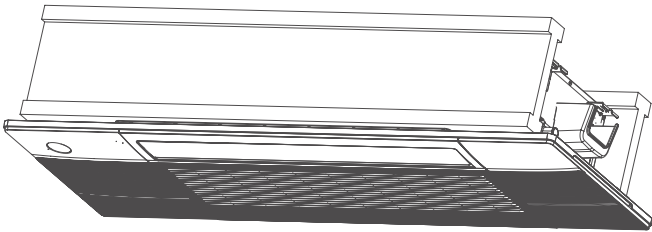

Model B

- Press the circular position to open the two screw covers, then remove the two screws.

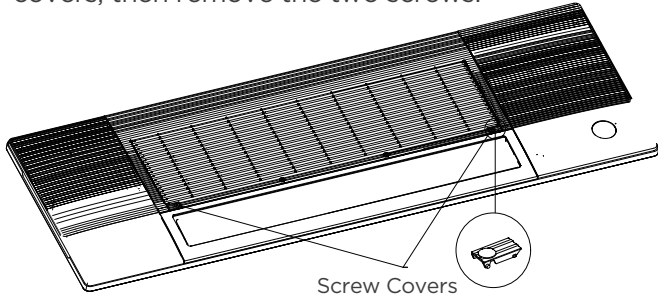

- Hold and open the air grille, then push both of the latch to the middle to unlock the air grille.

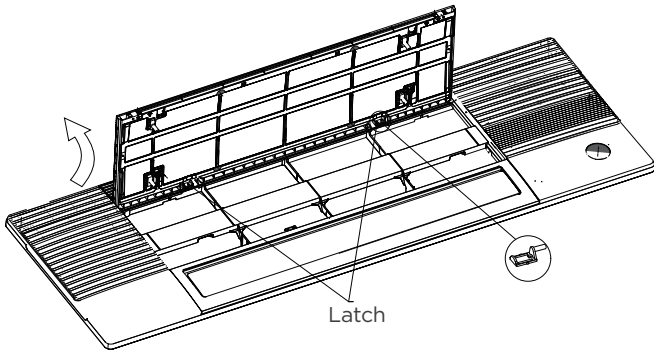

- Pull the panel grille out of the panel, fix the cassette panel to the one-way cassette by two plastic buckles.

plastic buckle

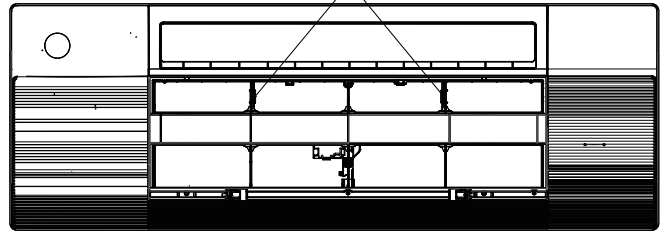

- Manually rotate the air deflector, fix the panel to the cassette by using 3×M4*22 screws and a ST3.9*16 screw.

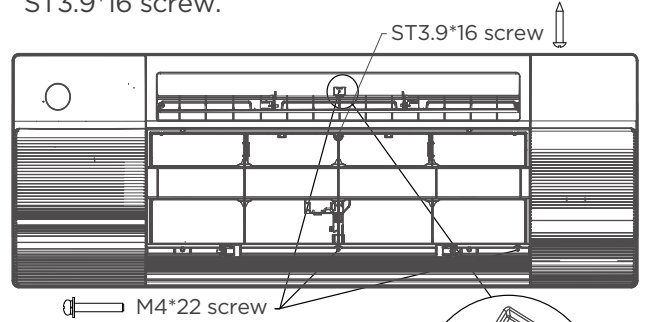

NOTE:

Eight M4*22 screws are supplied, two of which are spare. Two ST3.9*16 screws are supplied, one of which is spare.

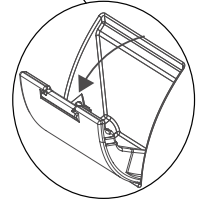

Before fixing this screw, you need to open the screw cover; and after fixing screw, please close the cover.

- Open the two covers on both sides of the panel, fix the panel to the cassette by using 3× M4*22 screws.

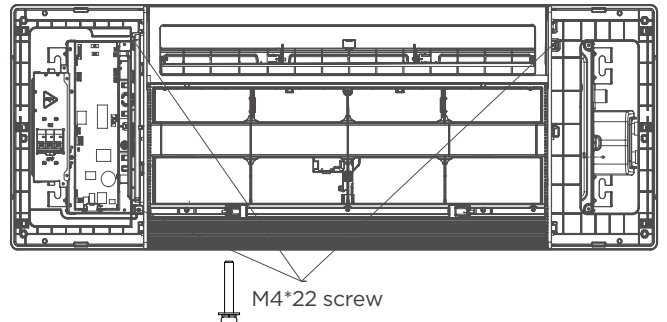

- Connect the display board to the main control board, up to four wires are required to connect.

NOTE: The corresponding colors or corresponding pins are connected each other.

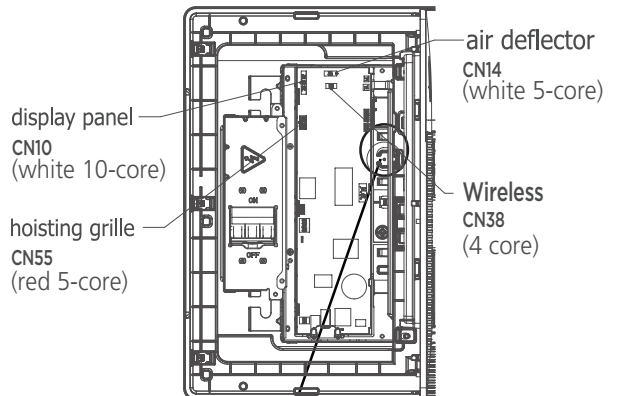

when connection is completed, please clip the wires to the buckle.

- Install the control box cover and turn the circuit breaker to ON, then close the two plastic covers on both sides of the panel.

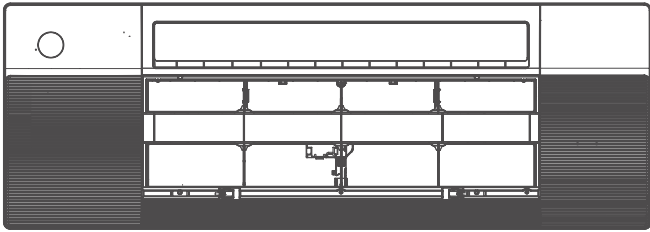
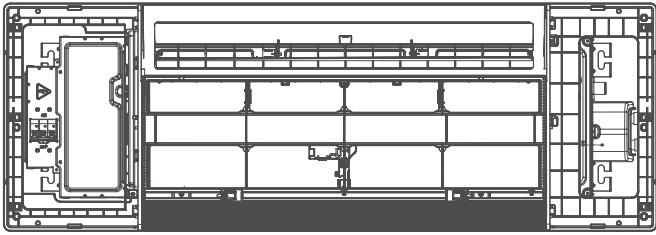

- Re-install the air grille by pushing the latch to lock it and fixing the two screws, then close the two screw covers.

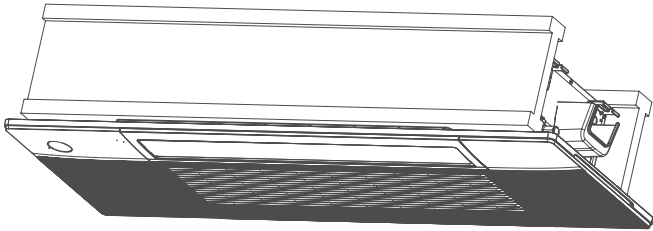

Step3: Optional parts installation

Wireless module

Wireless module, or named smart kit, if you choose this configuration, please follow the steps below to install.

NOTE:

If you choose this configuration, it is recommended that installing this wireless module during the step of panel installation.

- Remove the protective cap of the wireless module (smart kit).

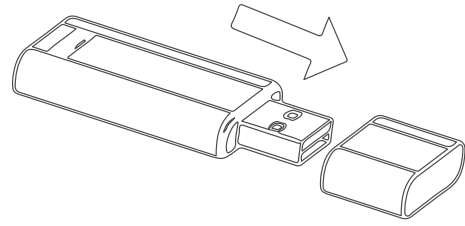

- Open the cover with display panel, loosen the screw and remove the cover.

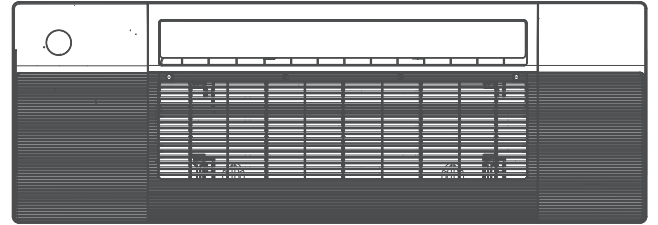

Loosen the screw and remove the cover

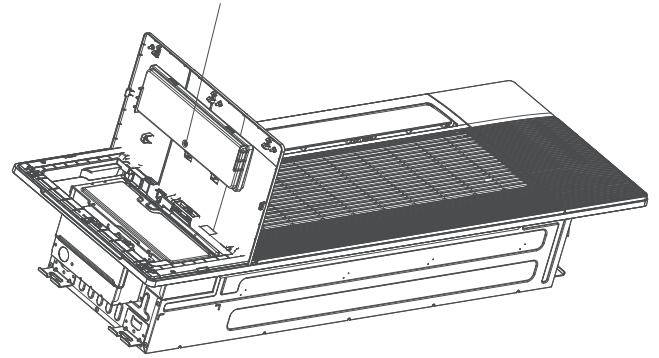

TEST RUN

CAUTION

Failure to perform the test run may result in unit damage, property damage, or personal injury.

Before test run

A test run must be performed after the entire system has been completely installed. Confirm the following points before performing the test:

- a) Indoor and outdoor units are properly installed.
- b) Piping and wiring are properly connected.
- c) No obstacles near the inlet and outlet of the unit that might cause poor performance or product malfunction.
- d) Refrigeration system does not leak.
- e) Drainage system is unimpeded and draining to a safe location.
- f) Heating insulation is properly installed.
- g) Grounding wires are properly connected.
- h) Length of the piping and additional refrigerant capacity have been recorded.
- i) Power voltage is the correct voltage for the air conditioner

Test Run Instructions

1. Open both the liquid and gas stop valves.
2. Turn on the main power switch and allow the unit to warm up.
3. Set the air conditioner to COOL mode.
4. For the Indoor Unit
 - a. Double check to see if the room temperature is being registered correctly.
 - b. Ensure the manual buttons on the indoor unit works properly.
 - c. Check to see that the drainage system is unimpeded and draining smoothly.
 - d. Ensure there is no vibration or abnormal noise during operation.
5. For the Outdoor Unit
 - a. Check to see if the refrigeration system is leaking.
 - b. Make sure there is no vibration or abnormal noise during operation.
 - c. Ensure the wind, noise, and water generated by the unit do not disturb your neighbors or pose a safety hazard.

NOTE: If the unit malfunctions or does not operate according to your expectations, please refer to the Troubleshooting section of the Owner's Manual before calling customer service.

Water Discharge Test

- Before the test, make sure that the water discharge pipeline is smooth, and check that each connection is sealed properly.
 - Conduct the water discharge test in the new room before the ceiling is paved.
1. Connect the power supply, and set the air conditioner to operate in the cool mode. Check the running sound of the drainage pump.
 2. Keep cool mode running at least 10 min.
 3. Stop the air conditioner. Wait for three minutes, and then check if there is anything unusual. If the water discharge piping layout is not correct, the excessive water flow will cause the water level error and "EE" error code will be displayed on the display panel. There may even be water overflowing from the water pan.
 4. Continue to add water until the alarm for excessive water levels is triggered. Check if the drainage pump drains water immediately. After three minutes, if the water level does not fall below the warning level, the unit will shut down. At this time, you need to turn off the power supply, and drain away the accumulated water before you can turn on the unit normally.
 5. Turn off the power supply, remove the water manually using the drainage plug, and put the test cap back to the original place.

CAUTION

The drainage plug at the bottom of the unit body is used to discharge accumulated water from the drain pan when the air conditioner malfunctions. When the air conditioner is operating normally, make sure the drainage plug is properly plugged to prevent water from leaking.

Packing and unpacking the unit

Instructions for packing and unpacking the unit:

Unpacking:

Indoor unit:

1. Cut the sealing tape on the carton with a knife, one cut on the left, one cut in the middle and one cut on the right.
2. Use the vice to take out the sealing nails on the top of the carton.
3. Open the carton.
4. Take out the middle support plate if it is included.
5. Take out the accessory package, and take out the connecting wire if it is included.
6. Lift the machine out of the carton and lay it flat.
7. Remove the left and right package foam or the upper and lower packaging foam, untie the packaging bag.

Outdoor Unit

1. Cut the packing belt.
2. Take the unit out of the carton.
3. Remove the foam from the unit.
4. Remove the packaging bag from the unit.

Packing:

Indoor unit:

1. Put the indoor unit into the packing bag.
2. Attach the left and right package foam or the upper and lower packaging foam to the unit.
3. Put the unit into the carton, then put accessory package in.
4. Close the carton and seal it with the tape.
5. Using the packing belt if necessary.

Outdoor unit:

1. Put the outdoor unit into the packing bag.
2. Put the bottom foam into the box.
3. Put the unit into the carton, then put the upper packaging foam on the unit.
4. Close the carton and seal it with the tape.
5. Using the packing belt if necessary.

NOTE: Please keep all packaging items if you may need in the future.



LIMITED WARRANTY

Breeze33 Products LLC (Breeze33®) warrants to the ORIGINAL PURCHASER that this Mini-Split HVAC Unit (the "Product") shall be free from defects in material, workmanship and/or manufacturing under normal use and service. Should your Breeze33 Product prove to be defective in material, workmanship and/or manufacturing under normal use during the durations outlined below, effective from the original purchase date, Breeze33 will replace defective parts or Product as outlined below.

FIRST SEVEN YEARS

If any part or Compressor supplied by Breeze33 fails due to defects in material or workmanship within the first seven (7) years of purchase date by the ORIGINAL PURCHASER, Breeze33 will replace the defective part or replace the entire Product free of charge.

TEN YEARS

If any Part or Compressor supplied by Breeze33 (i) installed in a "Residential Application" and (ii) has been registered with Breeze33 (the "Breeze33 Registration") within thirty (30) days from installation, and fails due to defects in material or workmanship within the first ten (10) years of purchase date by the ORIGINAL PURCHASER, Breeze33 will replace the defective part or replace the entire Product free of charge. "Residential Application" refers to parts or compressors installed in homes (single or multi-family), apartments, duplexes, or condominiums used solely for personal, household, or family use.

WHAT IS NOT COVERED?

This Limited Warranty applies only to Breeze33 Products that are installed by licensed HVAC contractors who are licensed for HVAC installation under applicable local and state laws (a "Licensed Contractor"), and where installation of the Product is completed in strict compliance with (A) all applicable building codes, ordinances, regulations and permits; (B) Breeze33's installation and operation instructions; and (C) good trade practices (each of the foregoing, the "Warranty Conditions"). In the event the Product is not installed by a Licensed Contractor and in strict compliance with each of the Warranty Conditions, this Limited Warranty, and Breeze33's obligations arising hereunder, shall be deemed null and void.

This Limited Warranty does not cover and Breeze33 is not liable for, (i) installation charges and/or costs related to the defective Products and/or parts; (ii) any labor charges and/or costs related to the defective Products and/or parts; (iii) Products which have been damaged as a result of any accident, misuse, abuse, neglect, improper installation or maintenance, the use of abrasive or organic solvent cleaners, modification; (iv) failure to use the Product in accordance with the instructions provided by Breeze33; and/or (v) Products not installed by a Licensed Contractor; (v) Products not installed in strict compliance with the Warranty Conditions; and/or (vi) Products for which the Breeze33 Registration have not been completed on or before the Registration Deadline.

PRODUCT REGISTRATION

This Limited Warranty, and Breeze33's obligations arising pursuant to this Limited Warranty are expressly conditioned upon the Product being registered with Breeze33 (the "Breeze33 Registration") within the earlier of (i) ninety (90) days following date the equipment is first installed by ; or (ii) one hundred and twenty (120) days from the date of purchase (the "Registration Deadline"). In the event the Breeze33 Registration is not completed on or before the Registration Deadline, this Limited Warranty shall become null and void and of no further force and effect. Product can be registered online:



HOW TO OBTAIN WARRANTY SERVICE

Complete the Warranty Claim Form to report the incident or contact our Warranty Department at breeze33.com.



Return failed Product with proof of purchase, your name, and address within thirty (30) days of failure to:

Breeze33 Products LLC
ATTN: 33Brands Quality Team
5700 Lee Road South
Maple Heights, OH 44137

LIMITATION OF LIABILITY

Breeze33's liability on any claim of any kind, including, without limitation, warranty, negligence and/or breach of contract, shall in no case exceed the purchase price paid by the Customer. IN NO EVENT SHALL BREEZE33 BE LIABLE FOR ANY SPECIAL, INCIDENTAL, CONSEQUENTIAL (INCLUDING, WITHOUT LIMITATION, DAMAGE TO PROPERTY) OR PUNITIVE DAMAGES, DAMAGES IN THE NATURE OF PENALTIES OR SIMILAR OR RELATED DAMAGES OF ANY KIND.

DISCLAIMER OF WARRANTIES

BREEZE33 EXPRESSLY DISCLAIMS ALL WARRANTIES, EXCEPT AS EXPLICITLY STATED HEREIN, TO THE FULLEST EXTENT PERMITTED BY LAW, WHETHER WRITTEN, ORAL, EXPRESS OR IMPLIED, INCLUDING ANY WARRANTY OF PERFORMANCE, MERCHANTABILITY, FITNESS FOR A PARTICULAR PURPOSE, AND NONINFRINGEMENT. THIS DISCLAIMER INCLUDES ANY ORAL WARRANTIES OR REPRESENTATIONS MADE OR IMPLIED BY ANY AGENT, EMPLOYEE, SUBCONTRACTOR, MANAGER, DIRECTOR AND/OR REPRESENTATIVE OF BREEZE33.

breeze33.com