

**SPLIT-TYPE**

ROOM AIR CONDITIONER

# Installation Manual

**breeze33<sup>®</sup>**

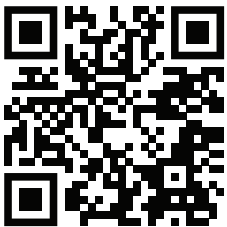

**REGISTER YOUR PRODUCT**

**IMPORTANT NOTE:**



Read this manual carefully before installing or operating your new air conditioning unit. Make sure to save this manual for future reference.

# CONTENTS

SAFETY PRECAUTIONS .....	02
PRODUCT OVERVIEW .....	12
PRODUCTION INSTALLATION .....	13
REFRIGERANT PIPING CONNECTION .....	27
WIRING PRECAUTIONS .....	30
AIR EVACUATION .....	33
NOTE ON ADDING REFRIGERANT .....	34
TEST RUN .....	35
COMMISSION .....	36
PACKING AND UNPACKING THE UNIT .....	37

## **Read this manual**

Inside you'll find many helpful hints on how to use and maintain your air conditioner properly. Just a little preventive care on your part can save you a great deal of time and money over the life of your air conditioner. These instructions may not cover every possible condition of use, so common sense and attention to safety is required when installing, operating and maintaining this product.

# SAFETY PRECAUTIONS

It is really important you read Safety Precautions Before Operation and Installation. Incorrect installation due to ignoring instructions can cause serious damage or injury. The seriousness of potential damage or injuries is classified as either a WARNING or CAUTION.

## Explanation of Symbols



### WARNING

This symbol indicates the possibility of personal injury or loss of life.



### CAUTION

This symbol indicates the possibility of property damage or serious consequences.

## WARNING

This appliance is not intended for use by persons (including children) with reduced physical, sensory or mental capabilities, or lack of experience and knowledge, unless they have been given supervision or instruction concerning use of the appliance by a person responsible for their safety. Children should be supervised to ensure that they do not play with the appliance.

## ELECTRICAL WARNINGS

- Only use the specified wire. If the wire is damaged, it must be replaced by the manufacturer, its service agent or similarly qualified persons in order to avoid a hazard.
- The product must be properly grounded at the time of installation, or electric shock may occur.
- For all electrical work, follow all local and national wiring standards, regulations, and the Installation Manual. Connect cables tightly, and clamp them securely to prevent external forces from damaging the terminal. Improper electrical connections can overheat and cause fire, and may also cause shock. All electrical connections must be made according to the Electrical Connection Diagram located on the panels of the indoor and outdoor units.
- All wiring must be properly arranged to ensure that the control board cover can close properly. If the control board cover is not closed properly, it can lead to corrosion and cause the connection points on the terminal to heat up, catch fire, or cause electrical shock.
- Disconnect must be incorporated in the fixed wiring in accordance with the wiring rules.
- Do not share the electrical outlet with other appliances. Improper or insufficient power supply can cause fire or electric shock.

## **⚠ WARNINGS FOR PRODUCT INSTALLATION**

- Turn off the air conditioner and disconnect the power before performing any installation or repairing. Failure to do so can cause electric shock.
- Installation must be performed by an authorized dealer or specialist. Defective installation can cause water leakage, electrical shock, or fire.
- Installation must be performed according to the installation instructions. Improper installation can cause water leakage, electrical shock, or fire. Contact an authorized service technician for repair or maintenance of this unit.
- This appliance shall be installed in accordance with national wiring regulations. Only use the included accessories, parts, and specified parts for installation.
- Using non-standard parts can cause water leakage, electrical shock, fire, and can cause the unit to fail.
- Install the unit in a firm location that can support the unit's weight. If the chosen location cannot support the unit's weight, or the installation is not done properly, the unit may drop and cause serious injury and damage.
- Install drainage piping according to the instructions in this manual. Improper drainage may cause water damage to your home and property.
- For units that have an auxiliary electric heater, do not install the unit within 1 meter (3 feet) of any combustible materials.
- For the units that have a wireless network function, the USB device access, replacement, maintenance operations must be carried out by professional staff.
- Do not install the unit in a location that may be exposed to combustible gas leaks. If combustible gas accumulates around the unit, it may cause fire.
- Do not turn on the power until all work has been completed.
- When moving or relocating the air conditioner, consult experienced service technicians for disconnection and reinstallation of the unit.
- How to install the equipment: please read the information for details in "indoor unit installation" and "outdoor unit installation" sections.

## **TAKE NOTE OF FUSE SPECIFICATIONS**

The air conditioner's circuit board (PCB) is designed with a fuse to provide overcurrent protection. The specifications of the fuse are printed on the circuit board, for example : T3.15AL/250VAC, T5AL/250VAC, T3.15A/250VAC, T5A/250VAC, T20A/250VAC, T30A/250VAC,etc.

**NOTE:** Only the blast-proof ceramic fuse can be used.

## **⚠ WARNING FOR USING FLAMMABLE REFRIGERANTS**

- Do not use means to accelerate the defrosting process or to clean, other than those recommended by the manufacturer.
- The appliance shall be stored in a room without continuously operating ignition sources (for example: open flames, an operating gas appliance or an operating electric heater).
- Do not pierce or burn.
- Be aware that refrigerants may not contain an odor.

### **For R454B refrigerant charge amount and minimum room area:**

The machine you purchased may be one of the types in the table below. The indoor and outdoor units are designed to be used together. Please check the machine you purchased. The indoor unit should be installed at least 7.3ft/2.2m above from the floor, the height of the room cannot be less than 7.3ft/2.2m, and the minimum room area of operating or storage should be as specified in the following table:

Model	Indoor unit	Outdoor unit
9K	BZ33-DIDU9-454-G3-P	BZ33-HYP09OUT2-454-G3-P
12K	BZ33-DIDU12-454-G3-P	BZ33-HYP12OUT2-454-G3-P
18K	BZ33-DIDU18-454-G3-P	BZ33-HYP18OUT2-454-G3-P

### Room size restriction

The appliances are connected via an air duct system to one or more rooms, the bottom of the air outlet of the air duct in the room should be at a height  $\geq 7.3\text{ft}/2.2\text{m}$  from the floor. In UL/CSA 60335-2-40, the R454B refrigerant belongs to mildly flammable refrigerants, which will limit the room area of the system service. Similarly, the total amount of refrigerant in the system should be less than or equal to the maximum allowable refrigerant charge, which depends on the room area serviced by the system.

### NOTE

The nouns in this section are explained as follows :

Mc: The actual refrigerant charge in the system.

A: the actual room area where the appliance is installed.

Amin: The required minimum room area.

Mmax: The allowable maximum refrigerant charge in a room.

Qmin: The minimum circulation airflow.

Anvmin The minimum opening area for connected rooms.

T Amin: The total area of the conditioned space (For appliances serving one or more rooms with an air duct system).

TA: The total area of the conditioned space connected by air ducts .

### Refrigerant charge and room area limitations

For the purpose of determination of room area (A) when used to calculate the maximum allowable refrigerant charge (Mmax) in an unventilated space, the following shall apply. The room area (A) shall be defined as the room area enclosed by the projection to the floor of the walls, partitions and doors of the space in which the appliance is installed. Spaces connected by only drop ceilings, ductwork, or similar connections shall not be considered a single space.

For units mounted higher than 1,8 m, spaces divided by partition walls which are no higher than 1,6 m shall be considered a single space.

For fixed appliances, rooms on the same floor and connected by an open passageway between the spaces can be considered a single room when determining compliance to Amin, if the passageway complies with all of the following.

- It is a permanent opening.
- It extends to the floor.
- It is intended for people to walk through.

For fixed appliances, the area of the adjacent rooms, on the same floor, connected by permanent opening in the walls and/or doors between occupied spaces, including gaps between the wall and the floor, can be considered a single room when determining compliance to Amin, provided all of the following are met.

- The space shall have appropriate openings according to Sec.2.
- The minimum opening area for natural ventilation Anvmin shall not be less than the following:

Height of outlet/m	A/m <sup>2</sup>	Mc/kg	Mmax/kg	Anvmin/m <sup>2</sup>
2.2	5	5.0	2.685	0.045
2.2	6	5.0	2.941	0.042
2.2	7	5.0	3.177	0.038
2.2	8	5.0	3.396	0.035
2.2	9	5.0	3.602	0.031
2.2	10	5.0	3.797	0.028
2.2	11	5.0	3.983	0.024
2.2	12	5.0	4.160	0.020
2.2	13	5.0	4.330	0.016
2.2	14	5.0	4.493	0.013
2.2	15	5.0	4.651	0.009
2.2	16	5.0	4.803	0.005
2.2	17	5.0	4.951	0.001

**Note:** Take the Mc =5.0kg as an example. For appliances serving one or more rooms with an air duct system, the room area calculation shall be determined based on the total area of the conditioned space (TA) connected by ducts taking into consideration that the circulating airflow distributed to all the rooms by the appliance integral indoor fan will mix and dilute the leaking refrigerant before entering any room.

### Opening conditions for connected rooms

When the openings for connected rooms are required, the following conditions shall be applied.

- The area of any openings above 300mm from the floor shall not be considered in determining compliance with Anvmin.
- At least 50% of the required opening area Anvmin shall be below 200mm from the floor.
- The bottom of the lowest openings shall not be higher than the point of release when the unit is installed and not more than 100mm from the floor.
- Openings are permanent openings which cannot be closed.
- For openings extending to the floor the height shall not be less than 20mm above the surface of the floor covering.
- A second higher opening shall be provided. The total size of the second opening shall not be less than 50% of minimum opening area for Anvmin and shall be at least 1.5 m above the floor.

NOTE: The requirement for the second opening can be met by drop ceilings, ventilation ducts, or similar arrangements that provide an airflow path between the connected rooms.

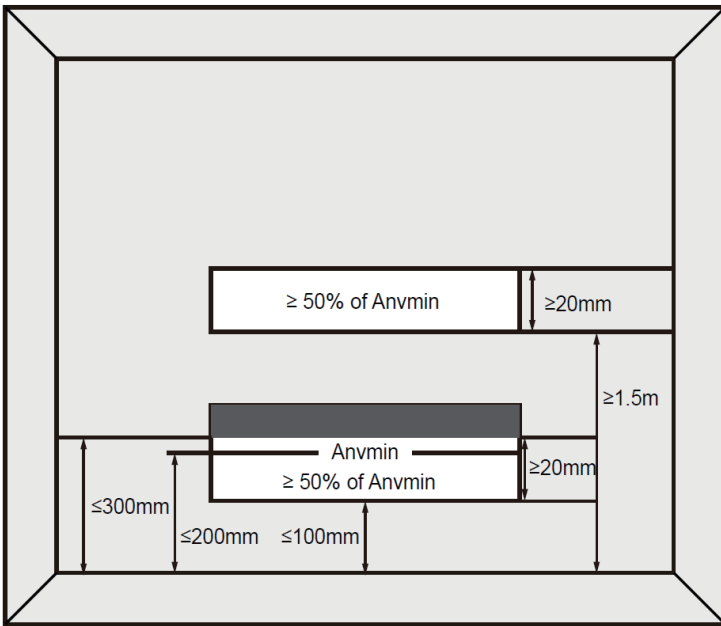

- The room into which refrigerant can leak, plus the connected adjacent room(s) shall have a total area of not less than  $T_{Amin}$ .
- The room area in which the unit is installed shall be not less than 20 %  $T_{Amin}$ .

<b>A<sub>min</sub>/T<sub>Amin</sub></b> <b>[ft<sup>2</sup>/m<sup>2</sup>]</b>	<b>h<sub>inst</sub>[ft/m]</b>					
	6.0~7.3/ 1.8~2.2	7.6/2.3	7.9/2.4	8.6/2.6	9.2/2.8	9.9/3.0
<b>m<sub>c</sub> or m<sub>REL</sub></b> <b>[ozs/kg]</b>	6.0~7.3/ 1.8~2.2	7.6/2.3	7.9/2.4	8.6/2.6	9.2/2.8	9.9/3.0
<=62.6/1.776	12/1.10					
63.4/1.8	60/5.53	57/5.29	55/5.07	51/4.68	47/4.35	44/4.06
70.5/2.0	67/6.15	64/5.88	61/5.64	56/5.20	52/4.83	49/4.51
77.5/2.2	73/6.76	70/6.47	67/6.20	62/5.72	58/5.31	54/4.96
84.6/2.4	80/7.38	76/7.06	73/6.76	68/6.24	63/5.80	59/5.41
91.7/2.6	86/7.99	83/7.64	79/7.32	73/6.76	68/6.28	64/5.86
98.7/2.8	93/8.60	89/8.23	85/7.89	79/7.28	73/6.76	68/6.31
105.8/3.0	100/9.22	95/8.82	91/8.45	84/7.80	78/7.24	73/6.76
112.8/3.2	106/9.83	102/9.41	97/9.01	90/8.32	84/7.73	78/7.21
119.9/3.4	113/10.45	108/9.99	104/9.58	96/8.84	89/8.21	83/7.66
126.9/3.6	120/11.06	114/10.58	110/10.14	101/9.36	94/8.69	88/8.11
134/3.8	126/11.68	121/11.17	116/10.70	107/9.88	99/9.17	93/8.56
141.0/4.0	133/12.29	127/11.76	122/11.27	112/10.40	104/9.66	97/9.01
148.1/4.2	139/12.90	133/12.34	128/11.83	118/10.92	110/10.14	102/9.46
155.1/4.4	146/13.52	140/12.93	134/12.39	124/11.44	115/10.62	107/9.91
162.2/4.6	153/14.13	146/13.52	140/12.96	129/11.96	120/11.11	112/10.37
169.2/4.8	159/14.75	152/14.11	146/13.52	135/12.48	125/11.59	117/10.82
176.3/5.0	166/15.36	159/14.69	152/14.08	140/13.00	130/12.07	122/11.27
Area formula	<p><b>A<sub>min</sub>/T<sub>Amin</sub></b> is the required minimum room area in ft<sup>2</sup>/m<sup>2</sup></p> <p><b>m<sub>c</sub></b> is the actual refrigerant charge in the system in oz/kg</p> <p><b>m<sub>REL</sub></b> is the refrigerant releasable charge in oz/kg</p> <p><b>h<sub>inst</sub></b> is the height of the bottom of the appliance relative to the floor of the room after installation.</p> <p><b>WARNING:</b> The minimum room area or minimum room area of conditioned space is based on releasable charge and total system refrigerant charge.</p>					

When the unit detects a refrigerant leak, the minimum airflow of the indoor unit is as follows:

Model	6K	9K	12K	18K
Nominal air volume	294CFM 500m <sup>3</sup> /h	294CFM 500m <sup>3</sup> /h	353CFM 600m <sup>3</sup> /h	588CFM 1000m <sup>3</sup> /h

**1. Installation** (where refrigerant pipes are allowed)

- Any person who is involved with working on a refrigerant circuit should hold a current valid certificate from an industry-accredited assessment authority, which authorizes their competence to handle refrigerants safely in accordance with an industry recognized assessment specification.
- Maintenance and repair requiring the assistance of licensed personnel shall be carried out under the supervision of the person competent in the use of flammable refrigerants.
- Protect refrigerant lines from physical damage.
- Ensure refrigerant lines comply with national refrigerant regulations.
- Mechanical connections shall be accessible for maintenance purposes.
- Be careful that foreign matter (oil, water, etc) does not enter the piping. Also, when storing the piping, securely seal the opening.
- Only licensed individuals should perform procedures that affect safety measures.
- Appliance shall be stored in a well ventilated area where the room size corresponds to the room area as specified for operation.
- Test joints with detection equipment, with the equipment both idle and operating, or under pressure matching these conditions after installation. DO NOT use detachable joints on the indoor side of the unit (use brazed or welded joints instead).
- In cases that require mechanical ventilation, ventilation openings shall be kept clear of obstruction.
- For units with refrigerant sensors: when the sensor detects a leak, the indoor unit will display an error code and emit a buzzing sound. The outdoor unit's compressor will immediately stop, and the indoor fan will start running. The refrigerant sensor has a 15-year service life. If it malfunctions, the indoor unit will display the error code "FHCC". The sensor cannot be repaired and must be replaced by the manufacturer with a specified sensor (this applies only to units with refrigerant sensors).
- non-duct connected appliances containing A2L refrigerants with the supply and return air openings in the conditioned space may have the body of the appliance may be installed in open areas such as false ceilings not being used as return air plenums, as long as the conditioned air does not directly communicate with the air of the false ceiling.

- 2. When a FLAMMABLE REFRIGERANT is used,** the requirements for installation space of appliance and/or ventilation requirements are determined according to
- the mass charge amount (M) used in the appliance,
  - the installation location,
  - the type of ventilation of the location or of the appliance.
  - piping material, pipe routing, and installation shall include protection from physical damage in operation and service, and be in compliance with national and local codes and standards, such as ASHRAE 15, IAPMO Uniform Mechanical Code, ICC International Mechanical Code, or CSA B52. All field joints shall be accessible for inspection prior to being covered or enclosed.
  - the protection devices, piping, and fittings shall be protected as far as possible against adverse environmental effects, for example, the danger of water collecting and freezing in relief pipes or the accumulation of dirt and debris;
  - the piping in refrigeration systems shall be so designed and installed to minimize the likelihood of hydraulic shock damaging the system;
  - that precautions shall be taken to avoid excessive vibration or pulsation;
  - the minimum floor area of the room shall be mentioned in the form of a table or a single figure without reference to a formula;
  - after completion of field piping for split systems, the field pipework shall be pressure tested with an inert gas and then vacuum tested prior to refrigerant charging, according to the following requirements:

- a. The minimum test pressure for the low side of the system shall be the low side design pressure and the minimum test pressure for the high side of the system shall be the high side design pressure, unless the high side of the system can not be isolated from the low side of the system in which case the entire system shall be pressure tested to the low side design pressure.
  - b. The test pressure after removal of pressure source shall be maintained for at least 1 h with no decrease of pressure indicated by the test gauge, with test gauge resolution not exceeding 5% of the test pressure.
  - c. During the evacuation test, after achieving a vacuum level specified in the manual or less, the refrigeration system shall be isolated from the vacuum pump and the pressure shall not rise above 1500 microns within 10 min. The vacuum pressure level shall be specified in the manual, and shall be the lessor of 500 microns or the value required for compliance with national and local codes and standards, which may vary between residential, commercial, and industrial buildings.
- field-made refrigerant joints indoors shall be tightness tested according to the following requirements: The test method shall have a sensitivity of 5 grams per year of refrigerant or better under a pressure of at least 0.25 times the maximum allowable pressure. No leak shall be detected.

### **3 . Qualification of workers**

Any maintenance, service and repair operations must be performed by qualified personnel. Every working procedure that affects safety means shall only be carried out by competent persons that joined the training and achieved competence should be documented by a certificate. The training of these procedures is carried out by national training organizations or manufacturers that are accredited to teach the relevant national competency standards that may be set in legislation. All training shall follow the ANNEX HH requirements of UL 60335-2-40 4th Edition.

Examples for such working procedures are:

- breaking into the refrigerating circuit;
- opening of sealed components;
- opening of ventilated enclosures.

#### **4. Ventilated area**

Ensure that the area is in the open or that it is adequately ventilated before breaking into the system or conducting any work. A degree of ventilation shall continue during the period that the work is carried out. The ventilation should safely disperse any released refrigerant and preferably expel it externally into the atmosphere.

#### **5. Wiring**

Check that wiring will not be subject to wear, corrosion, excessive pressure, vibration, sharp edges or any other adverse environmental effects. The check shall also take into account the effects of aging or continual vibration from sources such as compressors or fans.

#### **6. Detection of flammable refrigerants**

Under no circumstances shall potential sources of ignition be used in the searching for or detection of refrigerant leaks. A torch (or any other detector using a naked flame) shall not be used.

The following leak detection methods are deemed acceptable for refrigerant systems. Electronic leak detectors may be used to detect refrigerant leaks but, in the case of FLAMMABLE REFRIGERANTS, the sensitivity may not be adequate, or may need re-calibration. (Detection equipment shall be calibrated in a refrigerant-free area.) Ensure that the detector is not a potential source of ignition and is suitable for the refrigerant used. Leak detection equipment shall be set at a percentage of the LFL of the refrigerant and shall be calibrated to the refrigerant employed, and the appropriate percentage of gas (25 % maximum) is confirmed. Leak detection fluids are also suitable for use with most refrigerants but the use of detergents containing chlorine shall be avoided as the chlorine may react with the refrigerant and corrode the copper lineset.

**NOTE** Examples of leak detection fluids are

- bubble method,
- fluorescent method agents.

If a leak is suspected, all naked flames shall be removed/extinguished.

If a leakage of refrigerant is found which requires brazing, all of the refrigerant shall be recovered from the system, or isolated (by means of shut off valves) in a part of the system remote from the leak. See the following instructions of removal of refrigerant.

#### **7. Removal and evacuation**

When breaking into the refrigerant circuit to make repairs - or for any other purpose conventional procedures shall be used. However, for flammable refrigerants it is important that best practice be followed, since flammability is a consideration.

The following procedure shall be adhered to:

- safely remove refrigerant following local and national regulations;
- evacuate;
- purge the circuit with inert gas (optional for A2L);
- evacuate (optional for A2L);
- continuously flush or purge with inert gas when using flame to open circuit; and open the circuit.

The refrigerant charge shall be recovered into the correct recovery cylinders if venting is not allowed by local and national codes. For appliances containing flammable refrigerants, the system shall be purged with oxygen-free nitrogen to render the appliance safe for flammable refrigerants. This process might need to be repeated several times. Compressed air or oxygen shall not be used for purging refrigerant systems.

For appliances containing flammable refrigerants, refrigerants purging shall be achieved by breaking the vacuum in the system with oxygen-free nitrogen and continuing to fill until the working pressure is achieved, then venting to atmosphere,

and finally pulling down to a vacuum (optional for A2L). This process shall be repeated until no refrigerant is within the system (optional for A2L). When the final oxygen-free nitrogen charge is used, the system shall be vented down to atmospheric pressure to enable work to take place. The outlet for the vacuum pump shall not be close to any potential ignition sources, and ventilation must be available.

## **8. Charging procedures**

In addition to conventional charging procedures, the following requirements shall be followed:

- Work shall be undertaken with appropriate tools only (In case of uncertainty, please consult the manufacturer of the tools for use with flammable refrigerants)
- Ensure that contamination of different refrigerants does not occur when using charging equipment. Hoses or lines shall be as short as possible to minimize the amount of refrigerant contained in them.
- Cylinders shall be kept upright.
- Ensure that the refrigeration system is grounded prior to charging the system with refrigerant.
- Label the system when charging is complete (if not already).
- Extreme care shall be taken not to overfill the refrigeration system.
- Prior to recharging the system it shall be pressure tested with oxygen free nitrogen (OFN). The system shall be leak tested on completion of charging but prior to commissioning. A follow up leak test shall be carried out prior to leaving the site.

## **9. Recovery**

When removing refrigerant from a system, either for servicing or decommissioning, it is recommended good practice that all refrigerants are removed safely. When transferring refrigerant into cylinders, ensure that only appropriate refrigerant recovery cylinders are used. Ensure that the correct number of cylinders for holding the total system charge is available. All cylinders used are designated.

## **10. Unventilated areas**

For appliances containing more than for any refrigerating circuit, the manual shall include a statement advising that an unventilated area where the appliance using FLAMMABLE REFRIGERANTS is installed shall be so constructed that should any refrigerant leak, it will not stagnate so as to create a fire or explosion hazard. This shall include:

- a warning that if appliances with A2L REFRIGERANTS connected via an air duct system to one or more rooms are installed in a room with an area less than  $>A_{min}$  as determined in Clause GG.2, that room shall be without continuously operating open flames (for example an operating gas appliance) or other POTENTIAL IGNITION SOURCES (for example an operating electric heater, hot surfaces). A flame-producing device may be installed in the same space if the device is provided with an effective flame arrest;
- for appliances using A2L REFRIGERANTS connected via an air duct system to one or more rooms, a warning with the substance of the following: "Auxiliary devices which may be a POTENTIAL IGNITION SOURCE shall not be installed in the duct work. Examples of such POTENTIAL IGNITION SOURCES are hot surfaces with a temperature exceeding X °C and electric switching devices".

NOTE X is the maximum allowable surface temperature as defined in 22.117.

The manufacturer should specify other potential continuously operating sources known to cause ignition of the refrigerant used. The appliance shall be stored so as to prevent mechanical damage from occurring.

-for appliances using A2L refrigerants connected via an air duct system to one or more rooms, a warning that only auxiliary devices approved by the appliance manufacturer or declared suitable with the refrigerant shall be installed in connecting ductwork. The manufacturer shall list in the instructions all approved auxiliary devices by manufacturer and model number for use with the specific appliance, if those devices have a potential to become an ignition source.





- a warning that if appliances connected via an air duct system to one or more rooms with A2L REFRIGERANTS are installed in a room with an area less than 4min as determined in Clause GG.2. or installed in a room with an EFFECTIVE DISPERSAL VOLUME VED less than the minimum as determined by Clause 101.DVN.8, that room shall be without continuously operating open flames (e.g. an operating gas appliance) or other POTENTIAL IGNITION SOURCES (for e.g. an operating electric heater, hot surfaces). A flame-producing device may be installed in the same space if the device is provided with an effective flame arrest.

- for REFRIGERANT DETECTION SYSTEMS, the function and operation and required servicing measures;
- for LIMITED LIFE REFRIGERANT SENSORS Used in REFRIGERANT DETECTION SYSTEMS, the specified end-of-life and replacement instructions;
- REFRIGERANT SENSORS for REFRIGERANT DETECTION SYSTEMS Shall Only be replaced with sensors specified by the appliance manufacture; and instructions to verify actuation of mitigation actions per Annex GG or Annex 101.DVN as applicable.

For appliances using FLAMMABLE REFRIGERANTS with safety features that depend upon the proper function of a leak detection system used for leak mitigation, the instructions and unit markings shall contain the substance of the following:

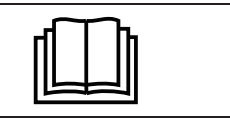
"LEAK DETECTION SYSTEM installed. Unit must be powered except for service." If any remote located REFRIGERANT SENSOR is employed to detect leaked refrigerant, such a remote located REFRIGERANT SENSOR shall also apply to this marking or be accompanied by such instructions.

### Explanation of symbols displayed on the indoor unit or outdoor unit

	<b>WARNING</b>	This symbol shows that this appliance used a flammable refrigerant. If the refrigerant is leaked and exposed to an external ignition source, there is a risk of fire.
	<b>CAUTION</b>	This symbol shows that the operation manual should be read carefully.
	<b>CAUTION</b>	This symbol shows that a licensed service professional should be handling this equipment with reference to the installation manual.
	<b>CAUTION</b>	
	<b>CAUTION</b>	This symbol shows that information is available such as the operating manual or installation manual.

# PRODUCT OVERVIEW

## NOTE ON ILLUSTRATIONS:

Illustrations in this manual are for explanatory purposes. The actual shape of your indoor unit may be slightly different.

The installation must be performed in accordance with the requirement of local and national standards. The installation may be slightly different in different areas.

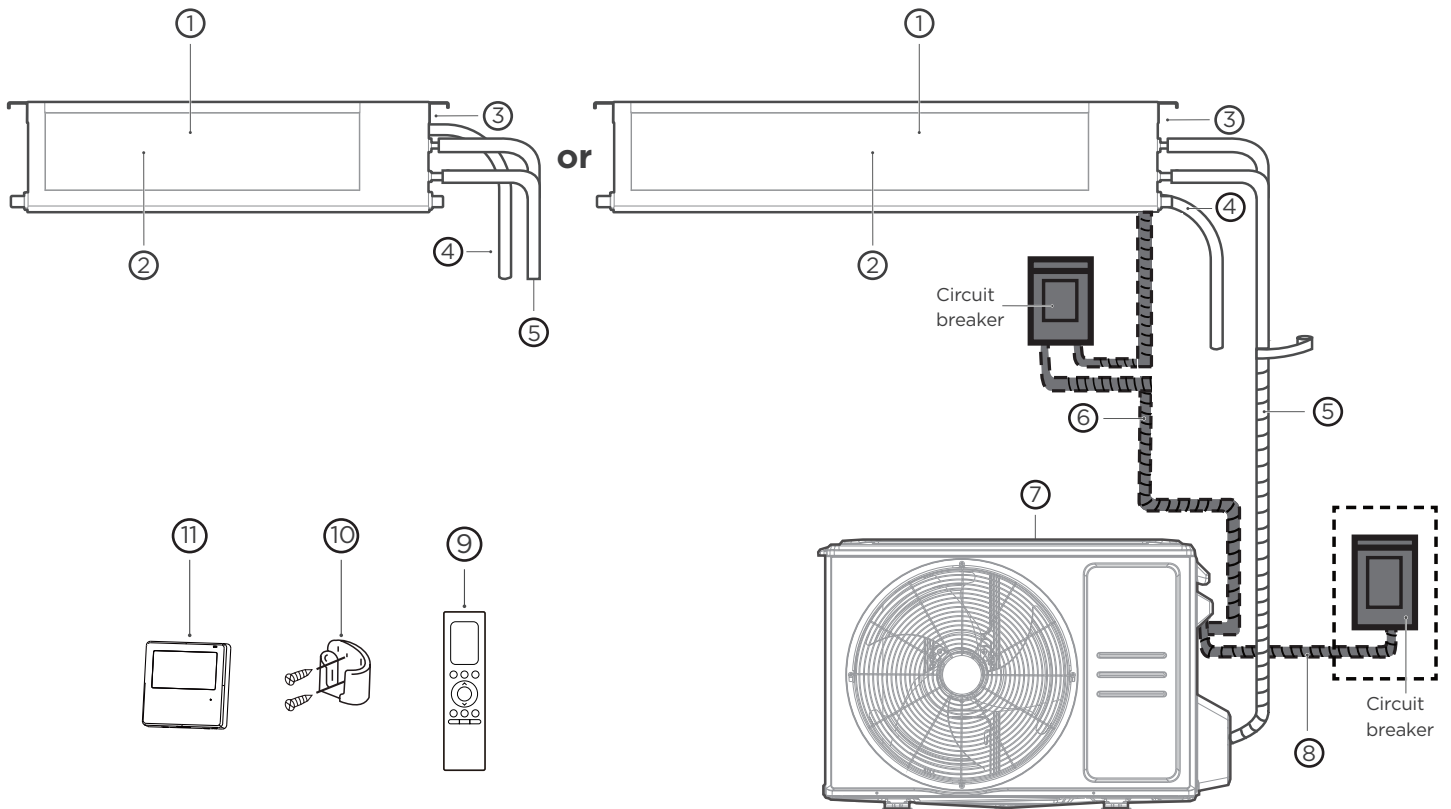

- |                        |   |   |
|------------------------|---|---|
| ① Air inlet            | ⑤ Refrigerant Piping<br>(purchase separately)       | ⑨ Remote Controller<br>(purchase separately)        |
| ② Air outlet           | ⑥ Connection cable<br>(purchase separately)         | ⑩ Remote controller holder<br>(purchase separately) |
| ③ Electric control box | ⑦ Outdoor Unit                                      | ⑪ Wired remote controller                           |
| ④ Drain pipe           | ⑧ Outdoor unit power cable<br>(purchase separately) |   |

## It would be perfect you had these tools



Gloves



Screwdriver & wrench

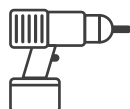

Hammer drill

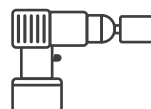

Core drill



Goggles & masks













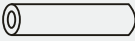

Vinyl tape

# PRODUCTION INSTALLATION

## ACCESSORIES

The air conditioner comes with the following accessories. Use all of the installation parts and accessories to install the air conditioner. Improper installation may result in water leakage, electrical shock and fire, or cause the equipment to fail. The items that are not included with the air conditioner must be purchased separately.

Name of Accessories	Q'ty(pc)	Shape	Name of Accessories	Q'ty(pc)	Shape
Manual	2-4		Magnetic ring (for wired controller connection)	1	
Refrigerant in/out pipe protection cover	2				
Copper nut	2				
Wired remote controller (with packing)	1		Magnetic ring (Hitch it on the connective cable between indoor unit and outdoor unit after installation.)	1	
Outlet pipe sheath	1				
Outlet pipe clasp	2		Display panel	1	
Drain joint & Seal ring	1		Remote controller & Battery (purchase separately)	1	
			Remote controller holder (purchase separately)	2	
				1	

### Optional accessories

There are two types of remote controls: wired and wireless.

Select a remote controller based on customer preferences and requirements and install in an appropriate place.

Refer to catalogs and technical literature for guidance on selecting a suitable remote controller.

### Display panel

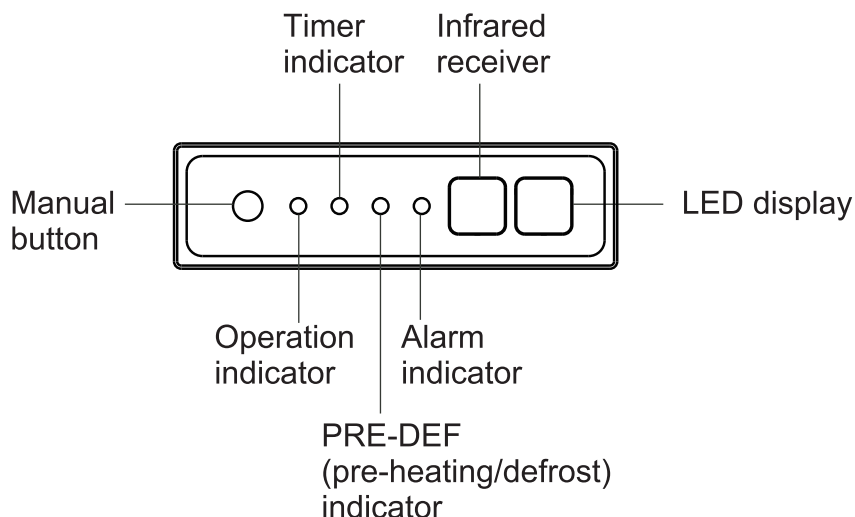

**MANUAL button:** This button selects the mode in the following order: AUTO, FORCED COOL, OFF.

**FORCED COOL mode:** In FORCED COOL mode, the Operation light flashes. The system will then turn to AUTO after it has cooled with a high wind speed for 30 minutes. The remote control will be disabled during this operation.

**OFF mode:** When the display panel is turned OFF, the unit turns off and the remote control is re-enabled.

## Size of connecting pipe

Parts you must purchase separately. Consult the dealer about the proper pipe size of the unit you purchased.

Name	Model	Pipe specification		Remark
		Liquid Side	Gas Side	
Connecting pipe assembly	6K	ø1/4in(ø6.35mm)	ø3/8in(ø9.52mm)	Pipes are not included in the accessories and you need to purchase it separately from the local dealer.
	9K	ø1/4in(ø6.35mm)	ø3/8in(ø9.52mm)	
	12K	ø1/4in(ø6.35mm)	ø3/8in(ø9.52mm)	
	18K	ø1/4in(ø6.35mm)	ø1/2in(ø12.7mm)	

# INSTALLATION SUMMARY

1

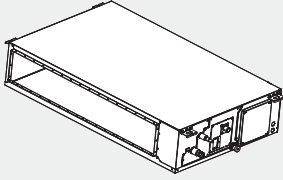

Install the indoor unit

2

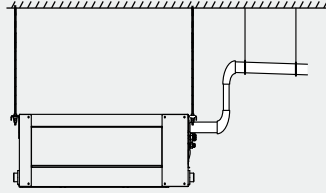

Install the drainpipe

3

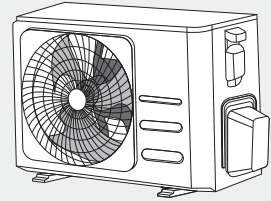

Install the outdoor unit

6

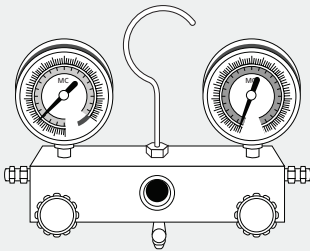

Evacuate the refrigeration system

5

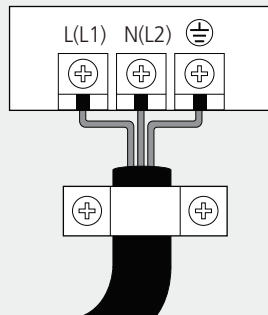

Connect the wires

4

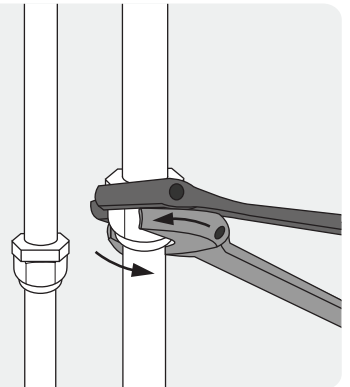

Connect the refrigerant pipes

7

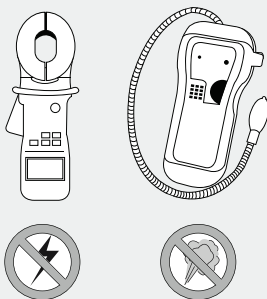

Perform a test run

# Install the Indoor Unit

1

## Select installation location



### NOTE

Before installing the indoor unit, you must choose an appropriate location. The following are standards that will help you choose an appropriate location for the unit.

### Proper installation locations meet the following standards:



Enough room exists for installation and maintenance.

Enough room exists for the connecting the pipe and drainpipe.



There is no direct radiation from heaters.



The air inlet and outlet are not blocked.

The airflow can fill the entire room.

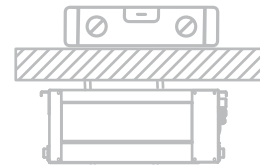

The ceiling is horizontal and its structure can sustain the weight of the indoor unit.

For North America, models with a cooling capacity of 6K to 18K only apply to one room. If 18K indoor unit is equipped with metal fan wheel, metal drain pan and fireproof sheet metal, it can supply multiple rooms.

### **DO NOT** install unit in the following locations:

- ⊘ Areas with oil drilling or fracking
- ⊘ Coastal areas with high salt content in the air
- ⊘ Areas with caustic gases in the air, such as hot springs
- ⊘ Areas that experience power fluctuations, such as factories
- ⊘ Enclosed spaces, such as cabinets
- ⊘ Kitchens that use natural gas
- ⊘ Areas with strong electromagnetic waves
- ⊘ Areas that store flammable materials or gas
- ⊘ Rooms with high humidity, such as bathrooms or laundry rooms

## 2

## Confirm installation sizes

### Installation place

The distance between the mounted indoor unit should meet the specifications illustrated in the following diagram.

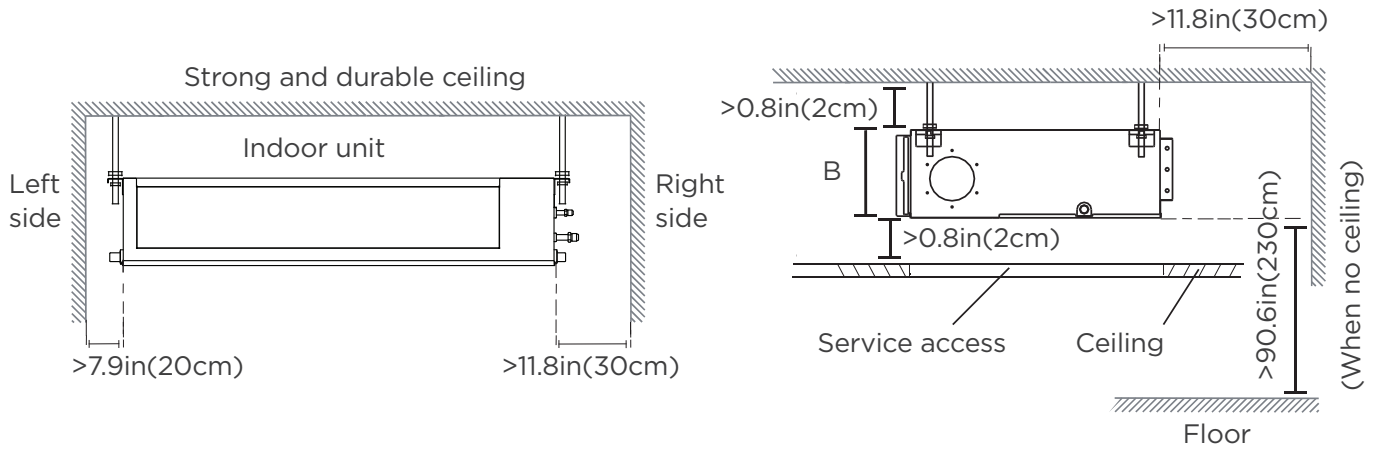

### Maintenance space

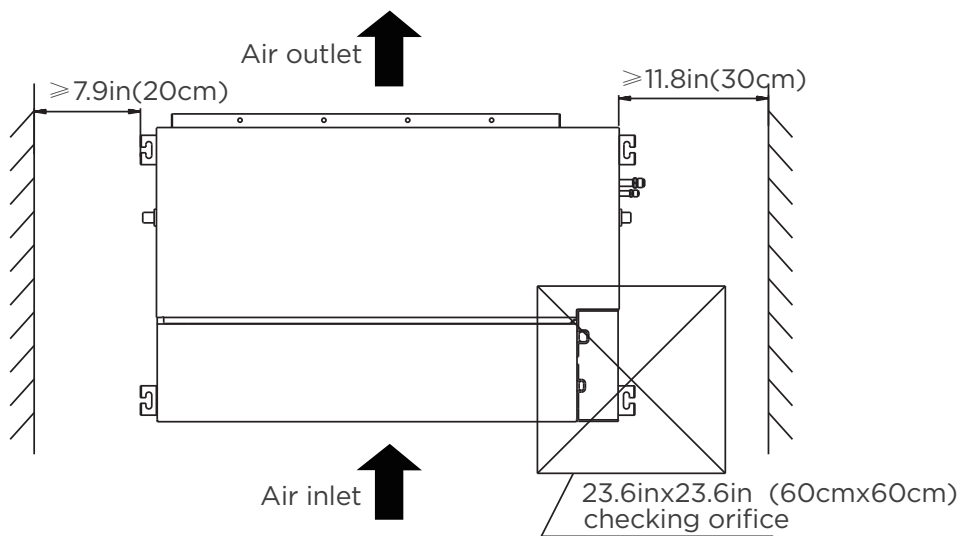

### 3

## Hang indoor unit

3.1. Please refer to the following diagrams to locate the four positioning screw bolt holes on the ceiling. Be sure to mark the paces where you will drill ceiling hook holes.

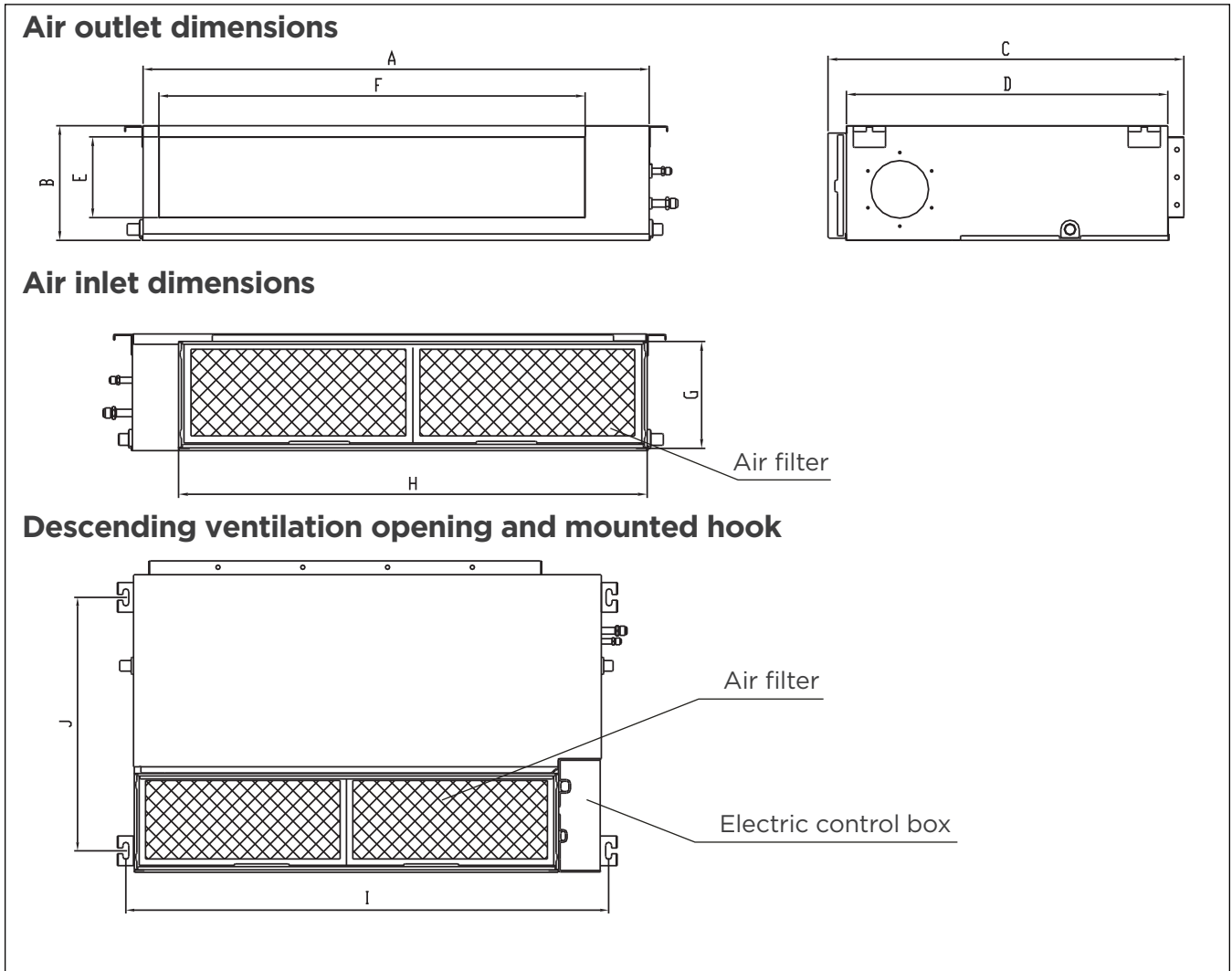

(unit: inch/mm)

MODEL (Btu/h)	Outline dimension				air outlet opening size		air return opening size		Size of mounted lug	
	A	B	C	D	E	F	G	H	I	J
6K/9K/12K	27.6/700	7.9/200	19.9/506	17.7/450	6.0/152	21.1/537	7.3/186	23.6/599	29.2/741	14.2/360
18K	34.6/880	8.3/210	26.5/674	23.6/600	5.4/136	27.8/706	7.5/190	30.8/782	36.2/920	20.0/508

### 3.2 Ceiling Bolt Installation Guidelines

#### 1) Wood

The mounting holes for upper foam are used for auxiliary positioning bolts (if the foam is damaged, the spacing between the actual lifting lugs shall be the standard).

Place the wood mounting across the roof beam, then install the hanging screw bolts.

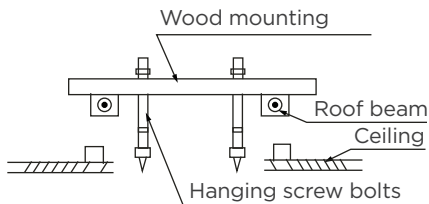

#### 2) New concrete bricks

Inlay or embed the screw bolts.



The design and specifications are subject to change without prior notice for product improvement. Consult with the sales agency or manufacturer for details. Any updates to the manual will be uploaded on the service website, please check for the latest version.

#### 3) Original concrete bricks

Use an embedding screw bolt, crock, and stick harness.

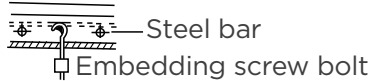

(Pipe hanging and embedding screw bolt)

#### 4) Steel roof beam structure

1. Install and use the supporting steel angle.

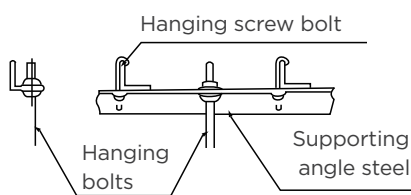

2. Install and fit pipes and wires after you have finished installing the main body. When choosing where to start, determine the direction of the pipes to be drawn out. Especially in cases where there is a ceiling involved, align the refrigerant pipes, drain pipes, and indoor and outdoor lines with their connection points before mounting the unit.

3. Install hanging screw bolts.

- Cut off the roof beam.
- Strengthen the point at which the cut was made. Consolidate the roof beam.

4. After you select an installation location, align the refrigerant pipes, drain pipes, as well as indoor and outdoor wires with their connection points before mounting the unit.

5. Drill 4 holes 4in (10cm) deep at the ceiling hook positions in the internal ceiling. Be sure to hold the drill at a 90° angle to the ceiling.

6. Secure the bolt using the washers and nuts provided.

7. Install the four suspension bolts.

8. Mount the indoor unit with at least two people to lift and secure it. Insert suspension bolts into the unit's hanging holes. Fasten them using the washers and nuts provided.

9. Position the indoor unit flat using a level indicator to prevent leaks.

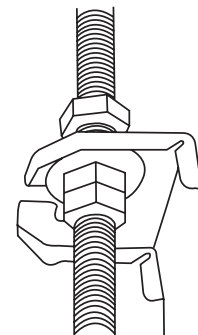

9. Position the indoor unit flat using a level indicator to prevent leaks.

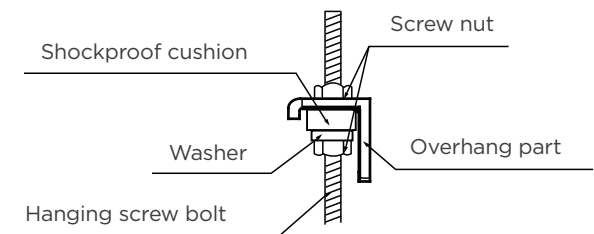

#### CAUTION

The unit body must be completely aligned with the hole. Ensure that the unit and the hole are the same size before moving on.

QS004I-T2(R454B)

16123000A3318

**NOTE:** Confirm the minimum drain tilt is 1/100 or more.

## 4

## Duct and accessories installation

1. Install the filter according to the size of the air inlet.
2. Install the canvas tie-in between the body and duct.
3. The air inlet and air outlet duct should be far enough apart enough to avoid air passage short-circuit.
4. Connect the duct according to the following diagram:

- Ceiling-mounted

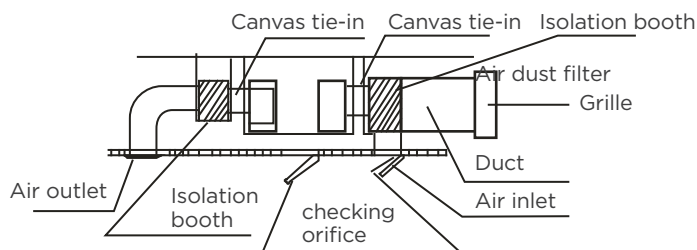

### NOTE:

1. The min. length of the duct should be more than 3.28ft/1m, and fix on the air inlet by screws (applicable to the unit that the air inlet filter is not fasten by screws).
2. The inlet of the air duct needs to be installed with a grille, which needs to be fixed to the air duct with screws.
3. Do not place the connecting duct weight on the indoor unit.
4. When connecting the duct, use a nonflammable canvas tie-in to prevent vibrating.
5. Insulation foam must be wrapped outside the duct to avoid condensate. An internal duct under layer can be added to reduce noise, if the end-user requires.

## 5

## Filter installation

1. Take off the ventilation panel and flange.

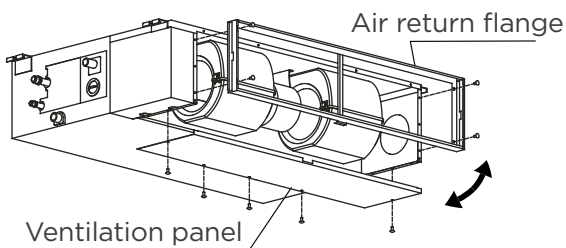

Bend the rear ventilation panel 90 degrees along the dotted line into a descending ventilation panel.

2. Change the mounting positions of the ventilation panel and air return flange.
3. When installing the filter mesh, fit it into the flange as illustrated in the following figure.

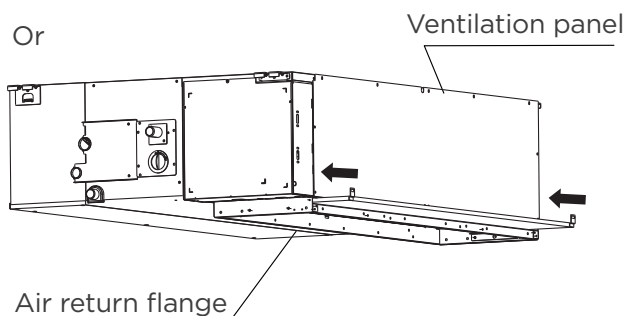
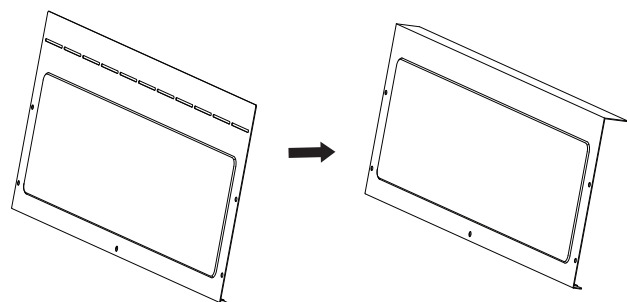
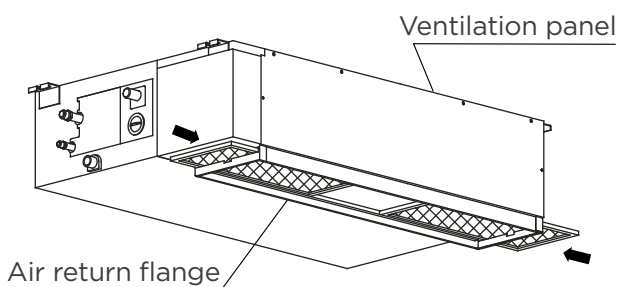

**NOTE:** All the figures in this manual are for demonstration purposes only. The air conditioner you have purchased may be slightly different in design, though similar in shape.

## 6

**Motor and drain pump maintenance**

(The rear ventilated panel is used as an example)

**1) Motor maintenance:**

1. Take off the ventilated panel.
2. Take off the blower housing.
3. Take off the motor.

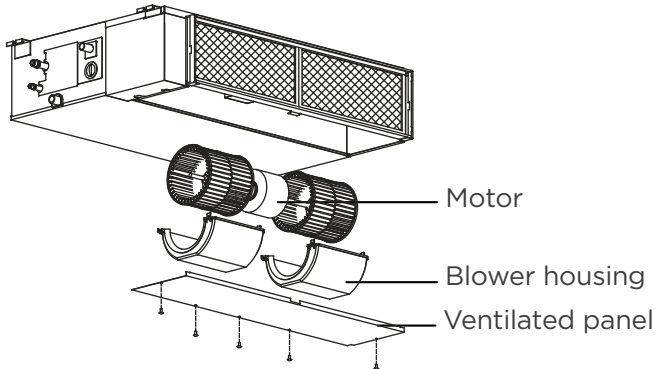
**2) Pump maintenance:**

1. Remove four screws from the drain pump.
2. Unplug the pump power supply and water level switch cable.
3. Detach the pump.

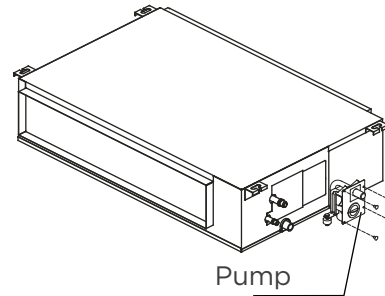

## 7

**Drill wall hole for connective piping**

1. Determine the location of the wall hole based on the location of the outdoor unit.
2. Using a 2.5in (65mm) or 3.54in (90mm) core drill, drill a hole in the wall. Make sure that the hole is drilled at a slight downward angle, so that the outdoor end of the hole is lower than the indoor end by about 0.5in (12mm). This will ensure proper water drainage.
3. Place the protective wall cuff in the hole. This protects the edges of the hole and will help seal it when you finish the installation process.

**⚠ CAUTION**

When drilling the wall hole, make sure to avoid wires, plumbing, and other sensitive components.

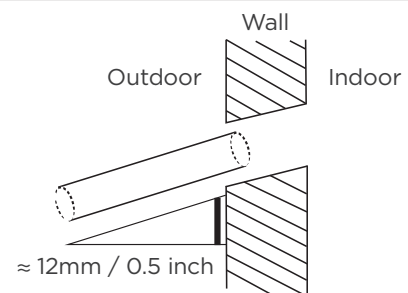

The drainpipe is used to drain water away from the unit. Improper installation may cause unit and property damage.

### ⚠ CAUTION

- Insulate all piping to prevent condensation, which could lead to water damage.
- If the drainpipe is bent or installed incorrectly, water may leak and cause a water-level switch malfunction.
- In HEAT mode, the outdoor unit will discharge water. Ensure that the drain hose is placed in an appropriate area to avoid water damage and slippage.
- **DO NOT** pull the drainpipe forcefully. This could disconnect it.

### NOTE ON PURCHASING PIPES

Installation requires a polyethylene tube (exterior diameter = 1.46-1.54in/3.7-3.9cm, interior diameter = 1.26in/3.2cm), which can be obtained at your local hardware store or dealer.

### Indoor Drainpipe Installation

Install the drainpipe as illustrated in the following Figure.

1. Cover the drainpipe with heat insulation to prevent condensation and leakage.
2. Attach the mouth of the drain hose to the unit's outlet pipe. Sheath the mouth of the hose and clip it firmly with a pipe clamp.

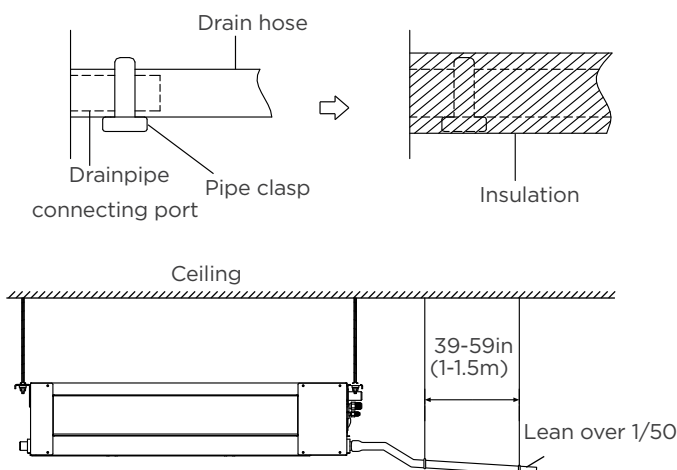

### NOTE ON DRAINPIPE INSTALLATION

- When using an extended drainpipe, tighten the indoor connection with an additional protection tube. This prevents it from pulling loose.
- The drainpipe should slope downward at a gradient of at least 1/50 to prevent water from flowing back into the air conditioner.
- To prevent the pipe from sagging, space hanging wires every 39-59in (1-1.5m).
- If the outlet of the drainpipe is higher than the body's pump joint, use a lift pipe for the indoor unit's exhaust outlet. The lift pipe must be installed no higher than 27.6in (70cm) from the ceiling board. The distance between the unit and the lift pipe must be less than 7.9in (20cm). Incorrect installation could cause water to flow back into the unit and flood.
- To prevent air bubbles, keep the drain hose level or slightly tilted up (<3in/75mm).

### Drainpipe installation for units with a pump

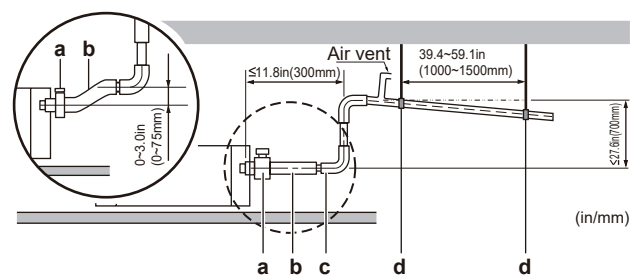

- a Metal clamp (accessory)
- b Drain hose (accessory)
- c Rising drain piping (vinyl pipe of 0.98in(25mm) nominal diameter and 1.26in(32mm) outer diameter) (field supply)
- d Hanging bars (field supply)

**NOTE:** When connecting multiple drainpipes, install the pipes as illustrated.

## Units with a pump

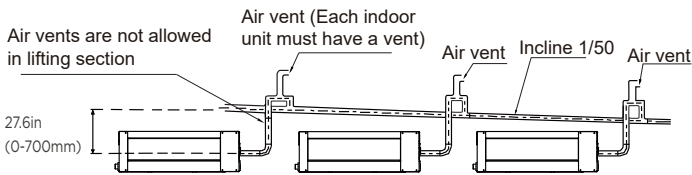

3. Pass the drain hose through the wall hole. Make sure the water drains to a safe location where it will not cause water damage or a slipping hazard.

**NOTE:** The drainpipe outlet should be at least 1.9in (5cm) above the ground. If it touches the ground, the unit may become blocked and malfunction. If you discharge the water directly into a sewer, make sure that the drain has a U or S pipe to catch odors that might otherwise come back into the house.

2. Turn on the unit in COOLING mode. You will hear the drain pump. Check whether the water is discharged properly (a 1-minute lag is possible, depending on the length of the drain pipe), Check whether water leaks from the joints.
3. Turn off the air conditioner and put the cap back on.

## Drainage test

Check whether the drainpipe is unhindered. This test should be performed on newly built houses before the ceiling is paved.

## Units with a pump.

1. Remove the test cover. Fill the water pan with 2 liters of water.

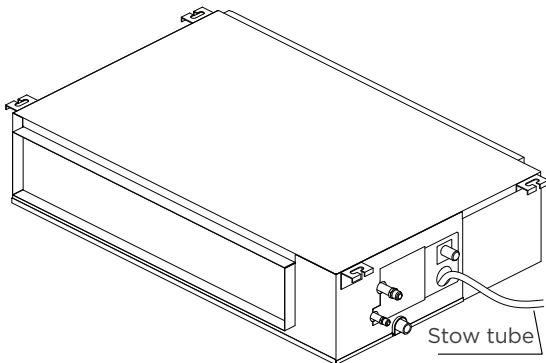
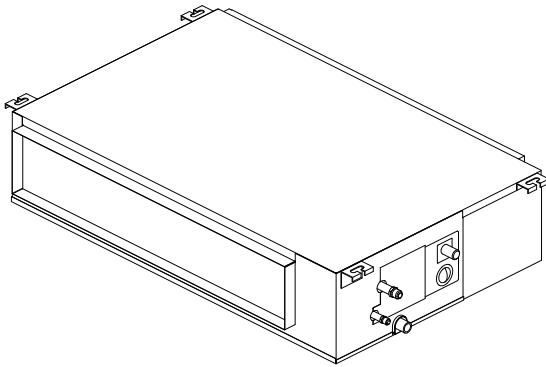

# Install Your Outdoor Unit

## 1 Select installation location

### NOTE : PRIOR TO INSTALLATION

Before installing the outdoor unit, you must choose an appropriate location. The following are standards that will help you choose an appropriate location for the unit.

Proper installation locations meet the following standards:

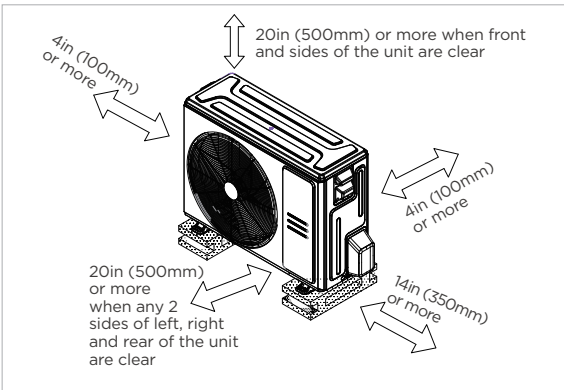

Good air circulation and ventilation.



Firm and solid—the location can support the unit and will not vibrate.



Noise from the unit will not disturb other people.



Protected from prolonged periods of direct sunlight or rain.



Where snowfall is anticipated, take appropriate measures to prevent ice buildup and coil damage.

Meets all spatial requirements shown in Installation Clearance Requirements above.

NOTE Install the unit by following local codes and regulations , there may be differ slightly between different regions.

### CAUTION:

#### SPECIAL CONSIDERATIONS FOR EXTREME WEATHER

##### If the unit is exposed to heavy wind:

Install unit so that air outlet fan is at a 90° angle to the direction of the wind. If needed, build a barrier in front of the unit to protect it from extremely heavy winds. See Figures below.

##### If the unit is frequently exposed to heavy rain or snow:

Build a shelter above the unit to protect it from the rain or snow. Be careful not to obstruct air flow around the unit.

##### If the unit is frequently exposed to salty air(seaside):

Use outdoor unit that is specially designed to resist corrosion.

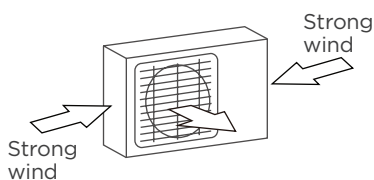

90° angle to the direction of the wind

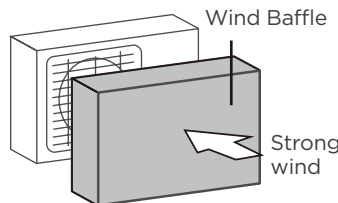

Build a wind Baffle to protect the unit

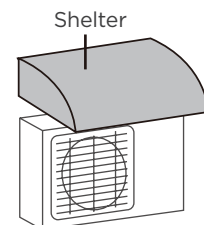

Build a shelter to protect the unit

#### DO NOT install unit in the following locations:

- Near an obstacle that will block air inlets and outlets.
- Near animals or plants that will be harmed by hot air discharge.
- In a location that is exposed to large amounts of dust
- Near a public street, crowded areas, or where noise from the unit will disturb others.
- Near any source of combustible gas.
- In a location exposed to a excessive amounts of salty air.

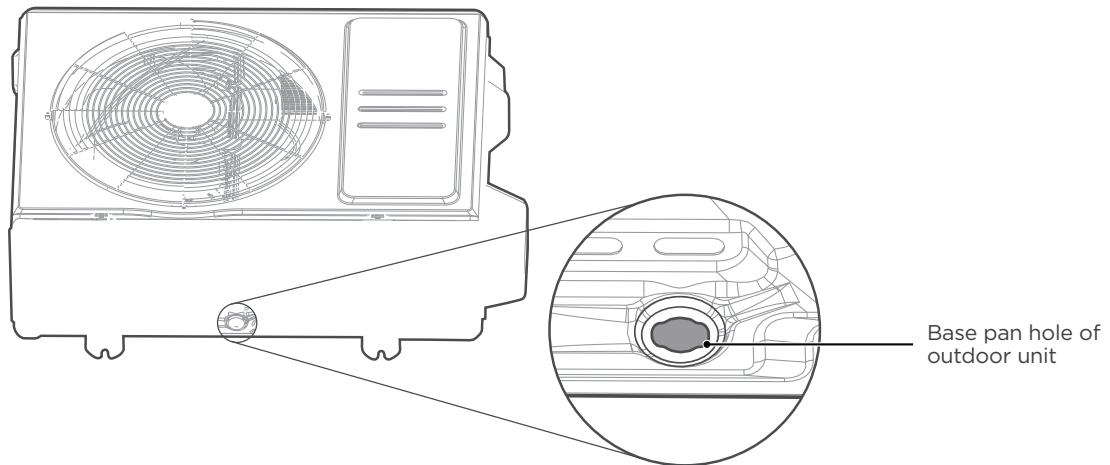
**Step 1:**

Find out the base pan hole of outdoor unit.

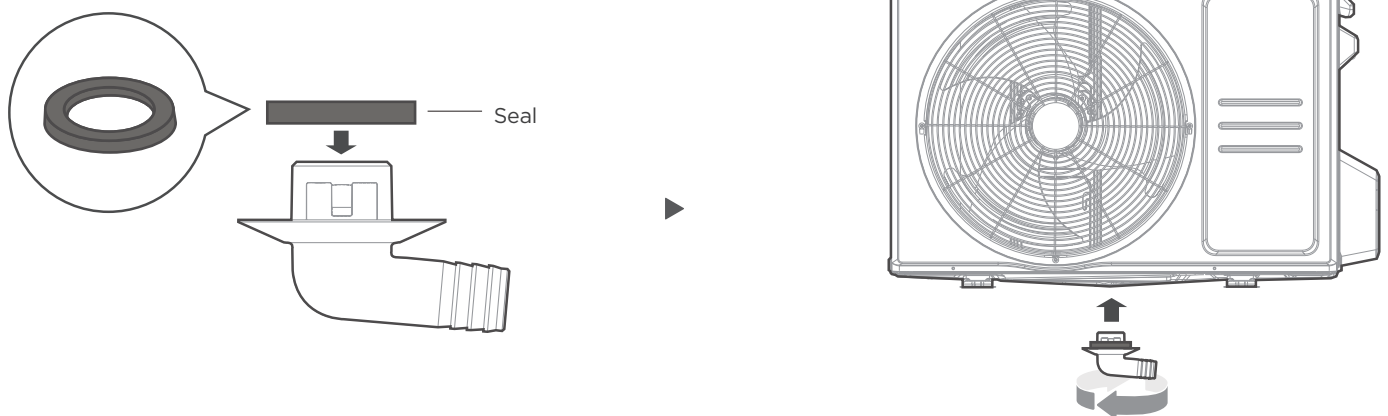
**Step 2:**

- Fit the rubber seal on the end of the drain joint that will connect to the outdoor unit.
- Insert the drain joint into the hole in the base pan of the unit. The drain joint will click in place.
- Connect a drain hose extension (not included) to the drain joint to redirect water from the unit during heating mode.

**! IN COLD CLIMATES**

In cold climates, make sure that the drain hose is as vertical as possible to ensure swift water drainage. If water drains too slowly, it can freeze in the hose and flood the unit.

### 3

## Anchor Outdoor Unit

### ⚠ WARNING

WHEN DRILLING INTO CONCRETE, EYE PROTECTION IS RECOMMENDED AT ALL TIME.

- The outdoor unit can be anchored to the ground or to a wall-mounted bracket with bolt(M10). Prepare the installation base of the unit according to the dimensions below.
- The following is a list of different outdoor unit sizes and the distance between their mounting feet. Prepare the installation base of the unit according to the dimensions below.

### Outdoor Unit Types and Specifications (Split Type Outdoor Unit)

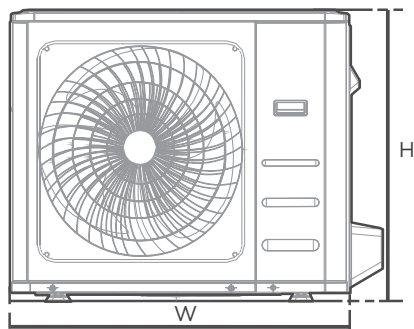

Front view

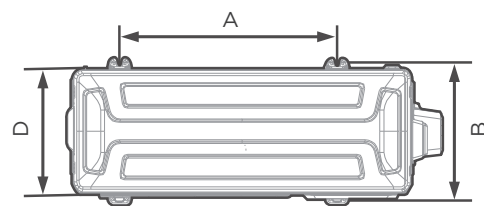

Top view

Outdoor Unit Dimensions W x H x D	Mounting Dimensions	
	Distance A	Distance B
30.1inx21.8inx11.9in (765mmx555mmx303mm)	17.8in (452mm)	11.3in (286mm)
31.7inx21.8inx12.9in (805mmx554mmx330mm)	20.1in (511mm)	12.5in (317mm)
35.0inx26.5inx13.5in (890mmx673mmx342mm)	26.1in (663mm)	13.9in (354mm)

### Rows of series installation

The relations between H, A and L are as follows.

	L	A
L ≤ H	$L \leq 1/2H$	9.8in (25 cm) or more
	$1/2H < L \leq H$	11.8in (30 cm) or more
L > H	Can not be installed	

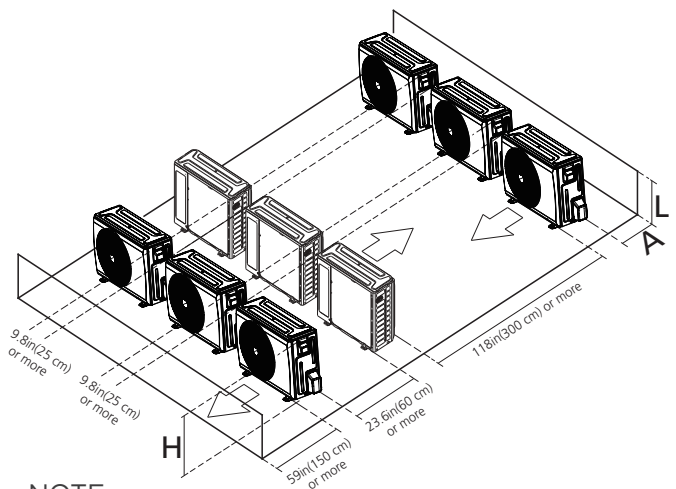

#### NOTE

H: Unit height

L: Height of the wall behind the unit

A: Distance between unit and wall

# REFRIGERANT PIPING CONNECTION

When connecting refrigerant piping, **DO NOT** let substances or gases other than the specified refrigerant enter the unit. The presence of other gases or substances will lower the unit's capacity, and can cause abnormally high pressure in the refrigeration cycle. This can cause explosion and injury.

## Notes on pipe length and elevation

The maximum length and drop height based on models.

Model	Length of piping	Maximum drop height
6K/9K/12K	82ft/25m	49.2ft/15m
18K	98.4ft/30m	65.6ft/20m

Ensure that the length of the refrigerant pipe, the number of bends, and the drop height between the indoor and outdoor units meets the requirements shown in the table next to it:

### ⚠ CAUTION

#### Oil traps

If oil flows back into the outdoor unit's compressor, this might cause liquid compression or deterioration of oil return. Oil traps in the rising gas piping can prevent this.

An oil trap should be installed every 20ft (6m) of vertical suction line riser (<36K). An oil trap should be installed every 32.8ft (10m) of vertical suction line riser (≥36K).

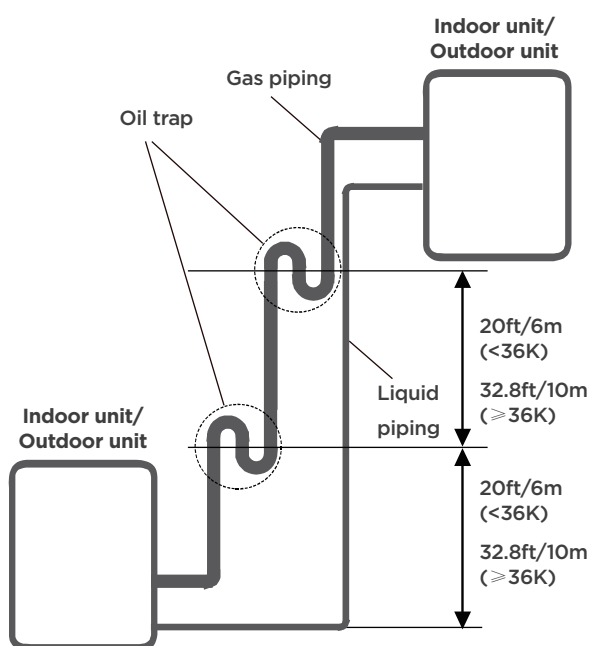

## Connection Instructions—Refrigerant Piping

### ⚠ CAUTION

- The branching pipe must be installed horizontally. An angle of more than 10° may cause malfunction.
- **DO NOT** install the connecting pipe until both indoor and outdoor units have been installed.
- Insulate both the gas and liquid piping to prevent condensation.

### Step 1: Cut pipes

When preparing refrigerant pipes, take extra care to cut and flare them properly. This will ensure efficient operation and minimize the need for future maintenance.

- Measure the distance between the indoor and outdoor units.
- Using a pipe cutter, cut the pipe a little longer than the measured distance.
- Make sure that the pipe is cut at a perfect 90° angle.

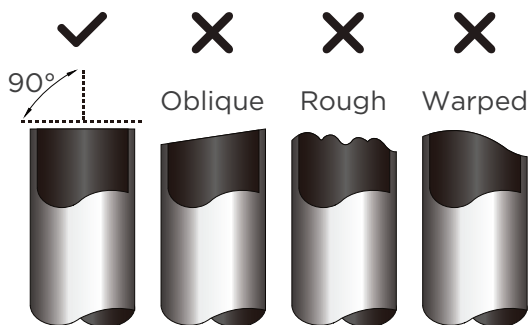

### 💡 DO NOT DEFORM PIPE WHILE CUTTING

Be extra careful not to damage, dent, or deform the pipe while cutting. This will drastically reduce the heating

### Step 2: Remove burrs

Burrs can affect the air-tight seal of refrigerant piping connection. They must be completely removed.

- Hold the pipe at a downward angle to prevent burrs from falling into the pipe.
- Using a reamer or deburring tool, remove all burrs from the cut section of the pipe.

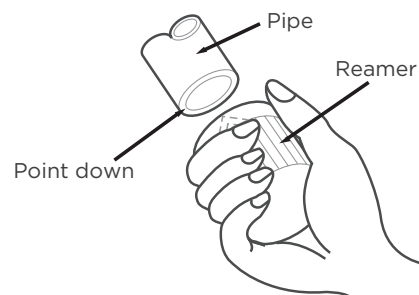

### Step 3: Flare pipe ends

Proper flaring is essential to achieve an airtight seal.

- After removing burrs from cut pipe, seal the ends with PVC tape to prevent foreign materials from entering the pipe.
- Sheath the pipe with insulating material.
- Place flare nuts on both ends of pipe. Make sure they are facing in the right direction, because you can't put them on or change their direction after flaring.

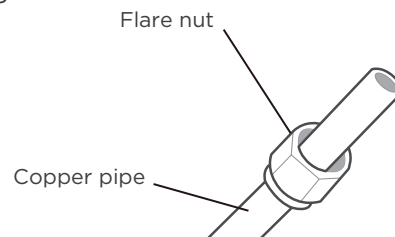

- Remove PVC tape from ends of pipe when ready to perform flaring work.

- Clamp flare from on the end of the pipe. The end of the pipe must extend beyond the flare form.

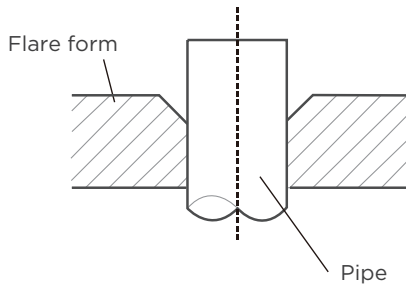

- Place flaring tool onto the form.
- Turn the handle of the flaring tool clockwise until the pipe is fully flared.

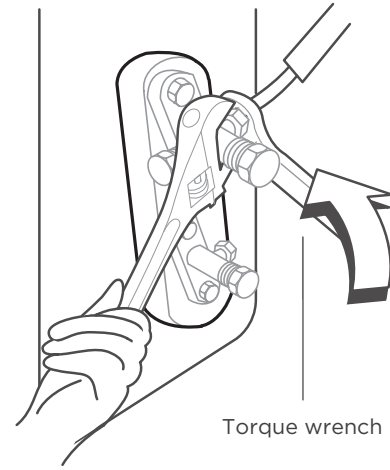

## PIPING EXTENSION BEYOND FLARE FORM

Pipe gauge	Tightening torque	Flare dimension(A)	Flare shape
Ø1/4in (Ø6.35mm)	18-20 N.m (180-200kgf.cm)	0.33-0.34in (8.4-8.7mm)	
Ø3/8in (Ø9.52mm)	32-39 N.m (320-390kgf.cm)	0.52-0.53in (13.2-13.5mm)	
Ø1/2in (Ø12.7mm)	49-59 N.m (490-590kgf.cm)	0.64-0.65in (16.2-16.5mm)	

- Remove the flaring tool and flare form, then inspect the end of the pipe for cracks and even flaring.

### ⚠ CAUTION

Ensure to wrap insulation around the piping. Direct contact with the bare piping may result in burns or frostbite.

- Make sure the pipe is properly connected. Over tightening may damage the bell mouth and under tightening may lead to leakage.

### 🔦 NOTICE

#### MINIMUM BEND RADIUS

Carefully bend the tubing in the middle according to the diagram below.

DO NOT bend the tubing more than 90° or more than 3 times.

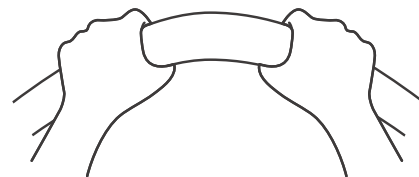

min-radius 3.9in (10cm)

- After connecting the copper pipes to the indoor unit, wrap the power cable, signal cable and the piping together with binding tape.

### 🔦 NOTICE

DO NOT intertwine signal cable with other wires. While bundling these items together. Do not intertwine or cross the signal cable with any other wiring.

## Step 4: Connect pipes

Connect the copper pipes to the indoor unit first, then connect it to the outdoor unit. You should first connect the low-pressure pipe, then the high pressure pipe.

- When connecting the flare nuts, apply a thin coat of refrigeration oil to the flared ends of the pipes.
- Align the center of the two pipes that you will connect.
- Tighten the flare nut snugly by hand.
- Using a wrench, grip the nut on the unit tubing.
- While firmly gripping the nut, use a torque wrench to tighten the flare nut according to the torque values in above table.

### 🔦 NOTICE

Use both a spanner and a torque wrench when connecting or disconnecting pipes to/from the unit.

# WIRING PRECAUTIONS

## ⚠ WARNING

BEFORE PERFORMING ANY ELECTRICAL WORK, READ THESE WARNINGS.

- All wiring must comply with local and national electrical codes, regulations and must be installed by a licensed electrician.
- All electrical connections must be made according to the Electrical Connection Diagram located on the panels of the indoor and outdoor units.
- If there is a serious safety issue with the power supply, stop work immediately. Explain your reasoning to the client, and refuse to install the unit until the safety issue is properly resolved.
- Power voltage should be within 90-110% of rated voltage. Insufficient power supply can cause malfunction, electrical shock, or fire.
- Installation of an external surge suppressor at the outdoor disconnect is recommended.
- If connecting power to fixed wiring, a switch or circuit breaker that disconnects all poles and has a contact separation of at least 1/8in (3mm) must be incorporated in the fixed wiring. The qualified technician must use an approved circuit breaker or switch.
- Only connect the unit to an individual branch circuit. Do not connect another appliance to that outlet.
- Make sure to properly ground the air conditioner.
- Every wire must be firmly connected. Loose wiring can cause the terminal to overheat, resulting in product malfunction and possible fire.
- Do not let wires touch or rest against refrigerant tubing, the compressor, or any moving parts within the unit.
- If the unit has an auxiliary electric heater, it must be installed at least 40in (1 m) away from any combustible materials.
- To avoid getting an electric shock, never touch the electrical components soon after the power supply has been turned off. After turning off the power, always wait 10 minutes or more before you touch the electrical components.
- Make sure that you do not cross your electrical wiring with your signal wiring.
- This may cause distortion, interference or possibly damage to circuit boards.
- No other equipment should be connected to the same power circuit.
- Connect the outdoor wires before connecting the indoor wires.

## ⚠ WARNING

BEFORE PERFORMING ANY ELECTRICAL OR WIRING WORK, TURN OFF THE MAIN POWER TO THE SYSTEM.

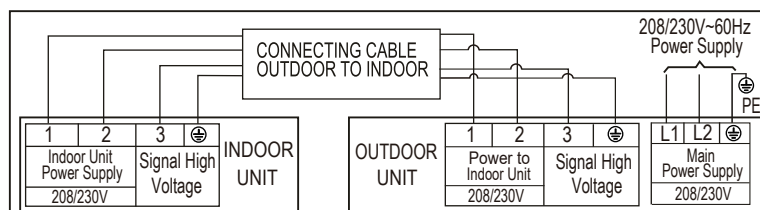

Connection Diagram (6K/9K/12K/18K)

## NOTE ON CIRCUIT BREAKER

When the maximum current of the air conditioner is more than 16A, a circuit breaker or leakage protection switch with protective device shall be used (purchased separately). When the maximum current of the air conditioner is less than 16A, the power cord of air conditioner shall be equipped with plug (purchased separately). In North America, the appliance should be wired according to NEC and CEC requirements.

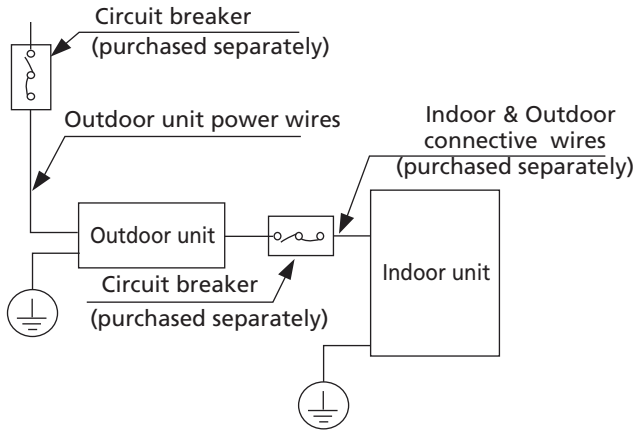

**NOTE:** The cognographs are for explanation purpose only. Your machine may be slightly different. The actual shape shall prevail.

## OUTDOOR UNIT WIRING

### ⚠ WARNING

Before performing any electrical or wiring work, turn off the main power to the system.

1. Prepare the cable for connection
  - a. You must first choose the right cable size. Choose the cable type according to the local electrical codes and regulations.
  - b. The size of the power supply cable, signal cable, fuse, and switch needed is determined by the Minimum Circuit Ampacity of the unit. The Minimum Circuit Ampacity is indicated on the nameplate located on the side panel of the unit. Refer to this nameplate to choose the right cable, fuse, or switch.
  - c. Using wire strippers, strip the rubber jacket from both ends of the signal cable to reveal approximately 5.9in (150mm) of wire.
  - d. Strip the insulation from the ends.
  - e. Using a wire crimper, crimp wires on the ends.

**NOTE:** When connecting the wires, strictly follow the wiring diagram found inside the electrical box cover.

2. Remove the electric cover of the outdoor unit. If there is no cover on the outdoor unit, take off the bolts from the maintenance board and remove the protection board.

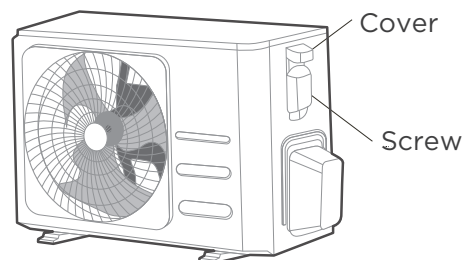

3. Connect the u-lugs to the terminals. Match the wire colors/labels with the labels on the terminal block. Firmly screw the wires of each wire to its corresponding terminal.
4. Clamp down the cable with the cable clamp.
5. Insulate unused wires with electrical tape. Keep them away from any electrical or metal parts.
6. Reinstall the cover of the electric control box.

# INDOOR UNIT WIRING

1. Prepare the cable for connection.
  - a. Using wire strippers, strip the rubber jacket from both ends of the signal cable to reveal about 5.9in (150mm) of the wire.
  - b. Strip the insulation from the ends of the wires.
2. Remove the cover of the electric control box on your indoor unit.
3. Connect the wires to the terminals. Match the wire colors/labels with the labels on the terminal block. Firmly screw the u-lug of each wire to its corresponding terminal. Refer to the Serial Number and Wiring Diagram located on the cover of the electric control box.

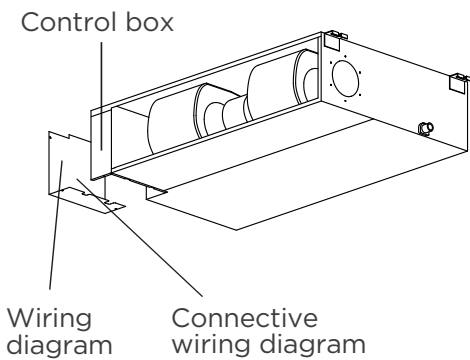

**Magnetic ring** (if supplied and packed with the accessories)

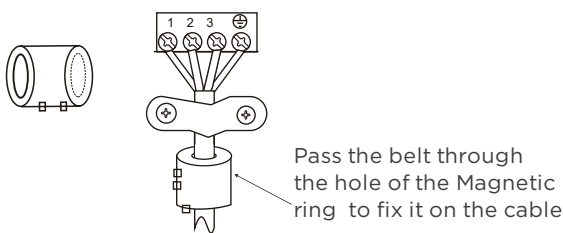

## ⚠ CAUTION

- While connecting the wires, please strictly follow the wiring diagram.
- The refrigerant circuit can become very hot. Keep the interconnection cable away from the copper tube.

4. Clamp down the cable with the cable clamp. The cable must not be loose or pull on the wires.
5. The display box needs to be installed in the electric control box, the display box needs to be installed inside the electric control, stuck on the electric control box sheet metal clips.

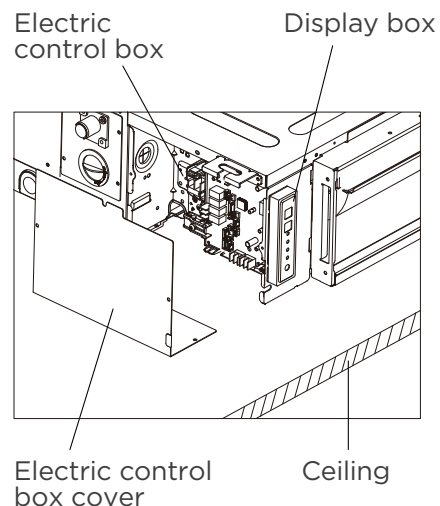
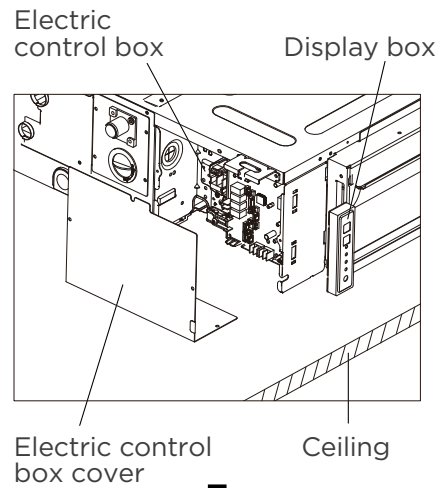

## NOTE:

- a. The display box needs to be installed to the outside of the indoor unit.
- b. The wiring of the wired controller needs to be completed inside the electric control box.
- c. The indoor unit needs to be ceiling mounted.

6. Reattach the electric box cover.

# AIR EVACUATION

## NOTE

When opening valve stems, turn the hexagonal wrench until it hits against the stopper. Do not try to force the valve to open further.

## Preparations and precautions

Air and foreign matter in the refrigerant circuit can cause abnormal rises in pressure, which can damage the air conditioner, reduce its efficiency, and cause injury. Use a vacuum pump and manifold gauge to evacuate the refrigerant circuit, removing any non-condensable gas and moisture from the system. Evacuation should be performed upon initial installation and when unit is relocated.

### BEFORE PERFORMING EVACUATION

- ☑ Check to make sure the connective pipes between the indoor and outdoor units are connected properly.
- ☑ Check to make sure all wiring is connected properly.

## Evacuation Instructions

1. Connect the charge hose of the manifold gauge to service port on the outdoor unit's low pressure valve.
2. Connect another charge hose from the manifold gauge to the vacuum pump.
3. Open the Low Pressure side of the manifold gauge. Keep the High Pressure side closed.
4. Turn on the vacuum pump to evacuate the system.
5. Run the vacuum for at least 15 minutes, or until the Compound Meter reads  $-76\text{cmHg}$  ( $-10^5\text{Pa}$ ).

### Outdoor unit

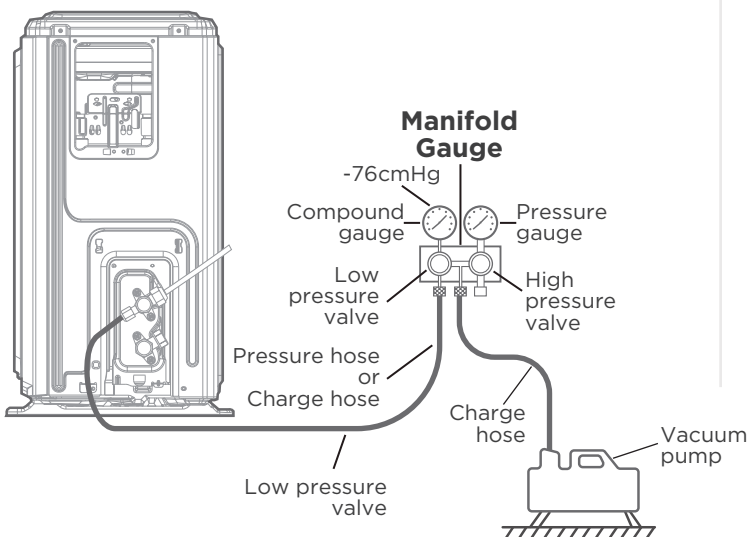

6. Close the Low Pressure side of the manifold gauge, and turn off the vacuum pump.
7. Wait for 5 minutes, then check that there has been no change in system pressure.
8. If there is a change in system pressure, refer to Gas Leak Check section for information on how to check for leaks. If there is no change in system pressure, unscrew the cap from the packed valve (high pressure valve).
9. Insert hexagonal wrench into the packed valve (high pressure valve) and open the valve by turning the wrench in a  $1/4$  counterclockwise turn. Listen for gas to exit the system, then close the valve after 5 seconds.
10. Watch the Pressure Gauge for one minute to make sure that there is no change in pressure. The Pressure Gauge should read slightly higher than atmospheric pressure.
11. Remove the charge hose from the service port.

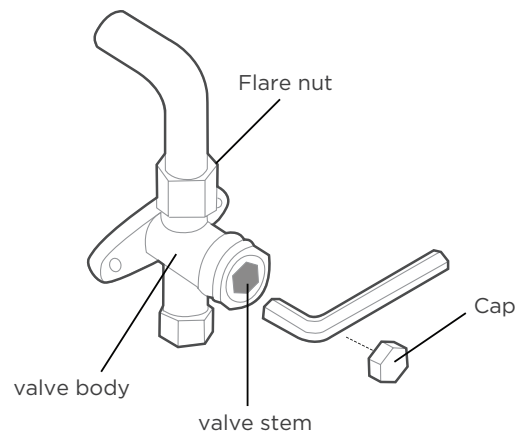

12. Using hexagonal wrench, fully open both the high pressure and low pressure valves.
13. Tighten valve caps on all three valves (service port, high pressure, low pressure) by hand. You may tighten it further using a torque wrench if needed.

# NOTE ON ADDING REFRIGERANT

**⚠ CAUTION**

**DO NOT** mix refrigerant types.

Some systems require additional charging depending on pipe lengths. In North America, the standard pipe length is 25ft (7.5m). The refrigerant should be charged from the service port on the outdoor unit's low pressure valve. The additional refrigerant to be charged can be calculated using the following formula (the refrigerant quantity added in the following table is a reference value and can be adjusted according to the actual situation):

Refrigerant	Liquid Side Diameter	
	Ø 1/4in (Ø 6.35)	Ø 3/8in (Ø9.52mm)
<b>R454B</b>	(Pipe length - standard length) x 15g/m (Pipe length - standard length) x 0.16oz/ft	(Pipe length - standard length) x 30g/m (Pipe length - standard length) x 0.32oz/ft

# TEST RUN

## CAUTION

Failure to perform the test run may result in unit damage, property damage, or personal injury.

### Before test run

A test run must be performed after the entire system has been completely installed. Confirm the following points before performing the test:

- a) Indoor and outdoor units are properly installed.
- b) Piping and wiring are properly connected.
- c) No obstacles near the inlet and outlet of the unit that might cause poor performance or product malfunction.
- d) Refrigeration system does not leak.
- e) Drainage system is unimpeded and draining to a safe location.
- f) Heating insulation is properly installed.
- g) Grounding wires are properly connected.
- h) Length of the piping and additional refrigerant capacity have been recorded.
- i) Power voltage is the correct voltage for the air conditioner

### Test Run Instructions

1. Open both the liquid and gas stop valves.
2. Turn on the main power switch and allow the unit to warm up.
3. Set the air conditioner to COOL mode.
4. For the Indoor Unit
  - a. Ensure the remote control and its buttons work properly.
  - b. Ensure the louvers move properly and can be changed using the remote control.
  - c. Double check to see if the room temperature is being registered correctly.
  - d. Ensure the indicators on the remote control and the display panel on the indoor unit work properly.
  - e. Ensure the manual buttons on the indoor unit works properly.
5. For the Outdoor Unit
  - a. Check to see if the refrigeration system is leaking.
  - b. Make sure there is no vibration or abnormal noise during operation.
  - c. Ensure the wind, noise, and water generated by the unit do not disturb your neighbors or pose a safety hazard.
6. Drainage Test
  - a. Ensure the drainpipe flows smoothly. New buildings should perform this test before finishing the ceiling.
  - b. Remove the test cover. Add 2,000ml of water to the tank through the attached tube.
  - c. Turn on the main power switch and run the air conditioner in COOL mode.
  - d. Listen to the sound of the drain pump to see if it makes any unusual noises.
  - e. Check to see that the water is discharged. It may take up to one minute before the unit begins to drain depending on the drainpipe.
  - f. Make sure that there are no leaks in any of the piping.
  - g. Stop the air conditioner. Turn off the main power switch and reinstall the test cover.

**NOTE:** If the unit malfunctions or does not operate according to your expectations, please refer to the Troubleshooting section of the Owner's Manual before calling customer service.











# COMMISSION

The indoor ducted units can be programmed for different static pressures or Real-time constant airflows, Use the following steps to set the static pressure or Real-time constant airflow.

## WHEN USING THE 120L WIRED CONTROLLER











### To set Static Pressure airflow

The factory default setting is SP1, The external static pressure can be manually changed to the fan curves 1,2,3,4,5,6,7,8.

- Press and hold ON/OFF  and FAN  for approximately 7 seconds.
- Press “^”  or “v”  to scroll through the menu and select “ 8 ”.
- Press and hold ON/OFF  for approximately 2 seconds , Press “^”  or “v”  to scroll through and select “ 1-8 ”.
- Press “☑”  or “ OK ” and the display board displays “ CS ”.
- Press and hold ON/OFF  and FAN  for approximately 7 seconds, Then exit test mode.

### To set Real-time constant airflow

Use the Automatic Airflow “ AF ” Adjustment function to realize Real-time constant airflows.

- Press and hold ON/OFF  and FAN  for approximately 7 seconds.
- Press “^”  or “v”  to scroll through the menu and select “ 8 ”.
- Press and hold ON/OFF  for approximately 2 seconds , Press “^”  or “v”  to scroll through and select “ AF ”.
- Press “☑”  or “ OK ” and the display board displays “ CS ”.
- Press and hold ON/OFF  and FAN  for approximately 7 seconds , Then exit test mode.

**NOTE :** Before commissioning, check the power connection of the machine, turn on the power, and keep the machine not working.





**NOTE :** If there is no change after airflow adjustment, perform the setting again.

**NOTE :** Low static pressure series 9K,12K,18K models, SP options can only be “ 1~4 ”.

## WHEN USING THE 120N WIRED CONTROLLER



### To set Static Pressure airflow

The factory default setting is SP1, The external static pressure can be manually changed to the fan curves 1,2,3,4,5,6,7,8.

- Press and hold Copy  for approximately 3 seconds, The lower right corner shows P:00, Press “ OK ”.
- Press “^”  to scroll through the menu , The lower right corner shows SP, Press “ OK ”.
- Press “^”  “v”  to scroll through the menu and select “1-8”, Press “ OK ”.
- Press "Back"  to exit test mode.

### To set Real-time constant airflow

Use the Automatic Airflow “ AF ” Adjustment function to realize Real-time constant airflows.

- Press and hold Copy  for approximately 3 seconds , The lower right corner shows P:00, Press “ OK ”.
- Press “^”  to scroll through the menu , The lower right corner shows AF, Press “ OK ”.
- Press "Back"  to exit test mode.

**NOTE:** T1, T2, T2b, T3, T4 are sub-menus for thermistors. DO NOT select to set the external static pressure.

**NOTE :** Before commissioning, check the power connection of the machine, turn on the power, and keep the machine not working.

**NOTE :** If there is no change after airflow adjustment, perform the setting again.

**NOTE :** Setting Static Pressure or Automatic Airflow need to use the Wired Remote Controller.

**NOTE :** Low static pressure series 6K,9K,12K,18K models, SP options can only be “ 1~4 ”.

# PACKING AND UNPACKING THE UNIT

Instructions for packing unpacking the unit:

Unpacking:

Indoor unit:

1. Cut the packing belt.
2. Unpack the package.
3. Take out the packing cushion and packing support.
4. Remove the packing film.
5. Take out the accessories.
6. Lift the machine out and lay it flat.

Outdoor Unit

1. Cut the packing belt.
2. Take the unit out of the package.
3. Remove the foam from the unit.
4. Remove the packing film from the unit.

Packing:

Indoor unit:

1. Put the indoor unit into the packing film.
2. Put the accessories in.
3. Place the packing cushion and packing support.
4. Put the indoor unit into the package.
5. Close the package and seal it.
6. Using the packing belt if necessary.

Outdoor unit:

1. Put the outdoor unit into the packing film.
2. Put the bottom foam into the box.
3. Put the outdoor unit into the package, then put the upper packaging foam on the unit.
4. Close the package and seal it.
5. Using the packing belt if necessary.

**NOTE:** Please keep all packaging items if you may need in the future.



## LIMITED WARRANTY

Breeze33 Products LLC (Breeze33®) warrants to the ORIGINAL PURCHASER that this Mini-Split HVAC Unit (the "Product") shall be free from defects in material, workmanship and/or manufacturing under normal use and service. Should your Breeze33 Product prove to be defective in material, workmanship and/or manufacturing under normal use during the durations outlined below, effective from the original purchase date, Breeze33 will replace defective parts or Product as outlined below.

### FIRST SEVEN YEARS

If any part or Compressor supplied by Breeze33 fails due to defects in material or workmanship within the first seven (7) years of purchase date by the ORIGINAL PURCHASER, Breeze33 will replace the defective part or replace the entire Product free of charge.

### TEN YEARS

If any Part or Compressor supplied by Breeze33 (i) installed in a "Residential Application" and (ii) has been registered with Breeze33 (the "Breeze33 Registration") within thirty (30) days from installation, and fails due to defects in material or workmanship within the first ten (10) years of purchase date by the ORIGINAL PURCHASER, Breeze33 will replace the defective part or replace the entire Product free of charge. "Residential Application" refers to parts or compressors installed in homes (single or multi-family), apartments, duplexes, or condominiums used solely for personal, household, or family use.

### WHAT IS NOT COVERED?

This Limited Warranty applies only to Breeze33 Products that are installed by licensed HVAC contractors who are licensed for HVAC installation under applicable local and state laws (a "Licensed Contractor"), and where installation of the Product is completed in strict compliance with (A) all applicable building codes, ordinances, regulations and permits; (B) Breeze33's installation and operation instructions; and (C) good trade practices (each of the foregoing, the "Warranty Conditions"). In the event the Product is not installed by a Licensed Contractor and in strict compliance with each of the Warranty Conditions, this Limited Warranty, and Breeze33's obligations arising hereunder, shall be deemed null and void.

This Limited Warranty does not cover and Breeze33 is not liable for, (i) installation charges and/or costs related to the defective Products and/or parts; (ii) any labor charges and/or costs related to the defective Products and/or parts; (iii) Products which have been damaged as a result of any accident, misuse, abuse, neglect, improper installation or maintenance, the use of abrasive or organic solvent cleaners, modification; (iv) failure to use the Product in accordance with the instructions provided by Breeze33; and/or (v) Products not installed by a Licensed Contractor; (v) Products not installed in strict compliance with the Warranty Conditions; and/or (vi) Products for which the Breeze33 Registration have not been completed on or before the Registration Deadline.

### PRODUCT REGISTRATION

This Limited Warranty, and Breeze33's obligations arising pursuant to this Limited Warranty are expressly conditioned upon the Product being registered with Breeze33 (the "Breeze33 Registration") within the earlier of (i) ninety (90) days following date the equipment is first installed by ; or (ii) one hundred and twenty (120) days from the date of purchase (the "Registration Deadline"). In the event the Breeze33 Registration is not completed on or before the Registration Deadline, this Limited Warranty shall become null and void and of no further force and effect. Product can be registered online:



## HOW TO OBTAIN WARRANTY SERVICE

Complete the Warranty Claim Form to report the incident or contact our Warranty Department at [breeze33.com](http://breeze33.com).



Return failed Product with proof of purchase, your name, and address within thirty (30) days of failure to:

Breeze33 Products LLC  
ATTN: 33Brands Quality Team  
5700 Lee Road South  
Maple Heights, OH 44137

## LIMITATION OF LIABILITY

Breeze33's liability on any claim of any kind, including, without limitation, warranty, negligence and/or breach of contract, shall in no case exceed the purchase price paid by the Customer. IN NO EVENT SHALL BREEZE33 BE LIABLE FOR ANY SPECIAL, INCIDENTAL, CONSEQUENTIAL (INCLUDING, WITHOUT LIMITATION, DAMAGE TO PROPERTY) OR PUNITIVE DAMAGES, DAMAGES IN THE NATURE OF PENALTIES OR SIMILAR OR RELATED DAMAGES OF ANY KIND.

## DISCLAIMER OF WARRANTIES

BREEZE33 EXPRESSLY DISCLAIMS ALL WARRANTIES, EXCEPT AS EXPLICITLY STATED HEREIN, TO THE FULLEST EXTENT PERMITTED BY LAW, WHETHER WRITTEN, ORAL, EXPRESS OR IMPLIED, INCLUDING ANY WARRANTY OF PERFORMANCE, MERCHANTABILITY, FITNESS FOR A PARTICULAR PURPOSE, AND NONINFRINGEMENT. THIS DISCLAIMER INCLUDES ANY ORAL WARRANTIES OR REPRESENTATIONS MADE OR IMPLIED BY ANY AGENT, EMPLOYEE, SUBCONTRACTOR, MANAGER, DIRECTOR AND/OR REPRESENTATIVE OF BREEZE33.

**[breeze33.com](http://breeze33.com)**