



INSTALLATION AND OPERATION MANUAL

Multi-Position Cased Coils

Cooling and Heat Pump Compatible

Factory Installed R454B Refrigerant Leakage Sensor

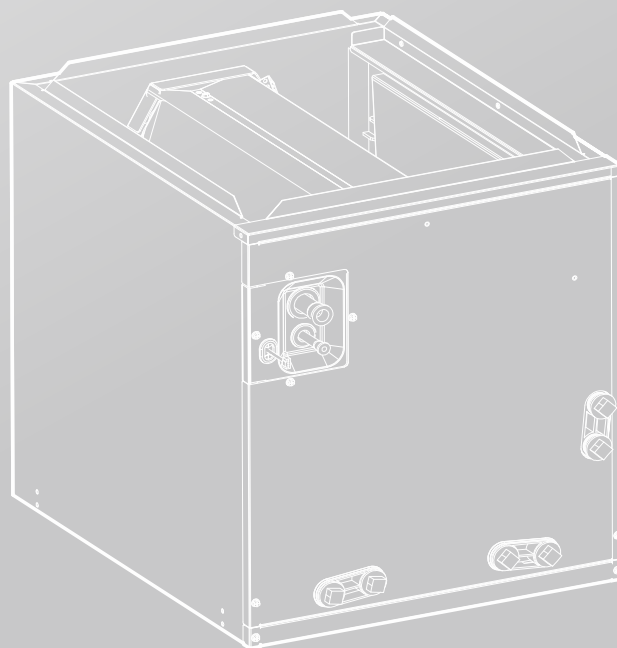

REGISTER YOUR PRODUCT



Please read this manual carefully and keep it for future reference.
All the pictures in this manual are for illustrations purpose only.



RECOGNIZE THIS SYMBOL AS AN INDICATION OF IMPORTANT SAFETY INFORMATION

WARNING

These instructions are intended as an aid to qualified licensed service personnel for proper installation, adjustment and operation of this unit. Read these instructions thoroughly before attempting installation or operation. Failure to follow these instruction may result in improper installation, adjustment, service or maintenance possibly resulting in fire, electrical shock, property damage, personal injury or death.

WARNING

This appliance is not intended for use by persons (including children) with reduced physical, sensory or mental capabilities, or lack of experience and knowledge, unless they have been given supervision or instruction concerning use of the appliance by a person responsible for their safety. Children should be supervised to ensure that they do not play with the appliance.

WARNING

Proposition 65: This appliance contains fiberglass insulation. Respirable particles of fiberglass are known to the state of California to cause cancer. For more information, go to www.P65Warnings.ca.gov.

CONTENTS

1 SAFETY

- 1.1 Safety Signs 01
- 1.2 Safety Precautions 02

2 ABOUT THE PRODUCT

- 2.1 Unit Dimensions 07
- 2.2 Codes & Regulations 08
- 2.3 Inspection upon Unit Arrival 08
- 2.4 Clearances 08
- 2.5 Refrigerant Sensor 09

3 INSTALLATION

- 3.1 Replacement Parts 09
- 3.2 Pre-installation Instruction 09
- 3.3 Installation and Trap Connection 10
- 3.4 Installation of Refrigerant Sensor 10
- 3.5 Refrigerant Charge and Room Area Limitations 11

4 REFRIGERANT LINE 15

5 DUCTWORK 15

6 AIR FLOW PERFORMANCE 17

7 DRAIN APPLICATION

- 7.1 Condensate Drain Piping 18
- 7.2 Drain Pan Installation 18

8 DISPOSAL 18

This document is customer property and is to remain with this unit.

These instructions do not cover all the different variations systems nor does it provide for every possible contingency to be met in connection with installation.

All phases of this installation must comply with national state and local codes. If additional information is required, please contact your local distributor.

1 SAFETY

1.1 Safety Signs



This is the general warning sign. It is used to alert the user to potential hazards. All safety messages that follow this sign shall be obeyed to avoid possible harm.

DANGER

Indicates a hazard with a high level of risk which, if not avoided, will result in death or serious injury.

WARNING

Indicates a hazard with a medium level of risk which, if not avoided, could result in death or serious injury.





CAUTION

Indicates a hazard with a low level of risk which, if not avoided, could result in minor or moderate injury.

NOTE

A situation that may cause damage to the equipment or loss of property.

Explanation of symbols displayed on the unit

	DANGER	This symbol shows that this appliance used a mild flammable refrigerant. If the refrigerant is leaked and exposed to an external ignition source, there is a risk of fire.
	WARNING	This symbol shows that appliance shall be installed, operated and stored in a room with a floor area not less than the minimum room area.
	CAUTION	This symbol shows that the operation manual should be read carefully.
	CAUTION	This symbol shows that a service personnel should be handling this equipment with reference to the installation manual.
	CAUTION	This symbol shows that information is available such as the operating manual or installation manual.

1.2 Safety Precautions

DANGER

Disconnect all power to unit before installing or servicing. More than one disconnect switch may be required to de-energize the equipment. Hazardous voltage can cause severe personal injury or death.

WARNING

If removal of the blower assembly is required, all disconnect switches supplying power to the equipment must be de-energized and locked (if not in sight of unit) so the field power wires can be safely removed from the blower assembly. Failure to do so may cause electrical shock resulting in personal injury or death.

WARNING

The unit must be permanently earthed. Failure to do so may result in electrical shock causing personal injury or death.

WARNING

Because of possible damage to equipment or personal injury, installation, service, and maintenance should be performed by a trained, qualified service personnel. Consumer service is recommended only for filter cleaning/replacement. Never operate the unit with the access panels removed.

WARNING

These instructions are intended as an aid to qualified, licensed service personnel for proper installation, adjustment and operation of this unit. Read these instructions thoroughly before attempting installation or operation. Failure to follow these instructions may result in improper installation, adjustment, service or maintenance, possibly resulting in fire, electrical shock, property damage, personal injury or death.

WARNING

PROPOSITION 65: This appliance contains fiberglass insulation. Respirable particles of fiberglass are known to State of California to cause cancer.

All manufacturer products meet current federal OSHA Guidelines for safety. California Proposition 65 warnings are required for certain products, which are not covered by the OSHA standards.

California's Proposition 65 requires warnings for products sold in California that contain or produce any of over 600 listed chemicals known to the State of California to cause cancer or birth defects such as fiberglass insulation, lead in brass, and combustion products from natural vapor.

All "new equipment" shipped for sale in California will have labels stating that the product contains and/or produces Proposition 65 chemicals. Although we have not changed our processes, having the same label on all our products facilitates manufacturing and shipping. We cannot always know "when, or if" products will be sold in the California market.

You may receive inquiries from customers about chemicals found in, or produced by, some of our heating and air-conditioning equipment, or found in natural vapor used with some of our products. Listed below are those chemicals and substances commonly associated with similar equipment in our industry and other manufacturers.

Glass Wool (Fiberglass) Insulation

Carbon Monoxide (CO)

Formaldehyde

Benzene

More details are available on the following websites: OSHA (Occupational Safety and Health Administration), at www.osha.gov and the State of California's OEHHA (Office of Environmental Health Hazard Assessment), at www.oehha.org. Consumer education is important since the chemicals and substances on the list are found in our daily lives. Most consumers are aware that products present safety and health risks, when improperly used, handled and maintained.

WARNING

The first 6 inches of supply air plenum and ductwork must be constructed of sheet metal as required by NFPA 90B. The supply air plenum or duct must have a solid sheet metal bottom directly under the unit with no openings, registers or flexible air ducts located in it. If flexible supply air ducts are used, they may be located only in the vertical walls of rectangular plenum, a minimum of 6 inches from the solid bottom. Metal plenum of duct may be connected to the combustible floor base, if not, it must be connected to the unit supply duct exposed to the supply air opening from the downflow unit. Exposing combustible (non-metal) material to the supply opening of a downflow unit can cause a fire resulting in property damage, personal injury or death.

WARNING

Only use this unit in well-ventilated area and ensure unit's airflow inlet and outlet would not be impeded by obstructions. Do not use this unit in the following locations:

Locations with mineral oil.

Locations with saline atmospheres, such as seaside locations.

Locations with sulfurous atmospheres, such as near natural hot springs.

Where high voltage electricity is present, such as in certain industrial locations.

On vehicles or vessels, such as trucks or ferry boats.

Where exposure to oily or very humid air may occur, such as kitchens.

In proximity to sources of electromagnetic radiation, such as high-frequency transmitters or other high strength radiation devices.

WARNING

Do not use means to accelerate the defrosting process or to clean, other than those recommended by the manufacturer.

The appliance shall be stored in a room that does not have continuously operating ignition sources (for example: open flames, an operating gas appliance or an operating electric heater).

Do not pierce or burn the unit.

Be aware that refrigerants may not contain an odor.

If refrigerant gas leaks during installation, ventilate the area immediately.

Comply with national gas regulations.

WARNING

This appliance is not intended for use by persons (including children) with reduced physical, sensory or mental capabilities, or persons who lack experience and knowledge, unless they are supervised or have been given instructions concerning the use of the appliance by a person responsible for their safety.

Children should be supervised to ensure that they do not play with the appliance.

Any person who is involved with working on or opening a refrigerant circuit should hold a current valid certificate from an industry-accredited assessment authority, which authorizes their competence to handle refrigerants safely in accordance with an industry recognized assessment credential.

Servicing shall only be performed as recommended by the equipment manufacturer.

Maintenance and repair requiring the assistance of other skilled personnel shall be carried out under the supervision of a person competent in the use of flammable refrigerants.

Prior to beginning work on systems containing flammable refrigerants, safety checks are necessary to minimize the risk of ignition.

WARNING

When repairing the refrigerating system, comply with the following precautions prior to conducting work on the system:

– shall be undertaken according to controlled procedures so as to minimize the risk of the presence of flammable gases or vapors while the work is being performed.

– All maintenance staff and others working in the local area shall be instructed on the nature of work being carried out. Work in confined spaces shall be avoided.

– The area shall be checked with an appropriate refrigerant detector prior to and during work, to ensure the technician is aware of potentially toxic or flammable environment. Ensure that the leak detection equipment being used is suitable for use with all applicable refrigerants, i.e. non-sparking, adequately sealed or intrinsically safe.

– If any hot work is to be conducted on the refrigerating equipment or any associated parts, appropriate fire extinguishing equipment shall be available and easily accessible. Have a dry powder or CO2 fire extinguisher adjacent to the charging area.

– When carrying out work in relation to a refrigerating system that involves exposing any pipe work, no sources of ignition shall be used in such a manner that it may lead to the risk of fire or explosion. All possible ignition sources, including cigarette smoking, should be kept sufficiently far away from the site of installation, repair, or removal and disposal of the unit, during which refrigerant can possibly be released into the surrounding space. Prior to beginning work, the area around the equipment is to be surveyed to make sure that there are no flammable hazards or ignition risks. "No Smoking" signs shall be clearly displayed.

Ensure that the area is in the open or that it is adequately ventilated before opening the system or conducting any hot work. A degree of ventilation shall continue during the period that the work is carried out. The ventilation should safely disperse any released refrigerant and preferably expel it externally into the surroundings.

Where electrical components are being changed, they shall be fit according to their purpose and to the correct specification. At all times the manufacturer's maintenance and service guidelines shall be followed. If in doubt, consult the manufacturer's technical department for assistance. The following checks shall be applied to installations using flammable refrigerants:

– The actual refrigerant charge is in accordance with the room size within which the refrigerant containing parts are installed;

– The ventilation machinery and outlets are operating adequately and are not obstructed.

– If an indirect refrigerating circuit is being used, the secondary circuit shall be checked for the presence of refrigerant.

– Equipment marking must remain visible and legible. Markings and signs that are illegible shall be corrected.

Refrigerating pipe or components are installed in a position where they are unlikely to be exposed to any substances which may corrode refrigerant containing components, unless the components are constructed of materials that are inherently resistant to corrosion or are suitably protected against corrosion.

Repair and maintenance of electrical components shall include initial safety checks and component inspection procedures. If a fault exists that could compromise safety, then no electrical supply shall be connected to the circuit until the fault has been dealt with satisfactorily.

If the fault cannot be corrected immediately but it is necessary to continue operation, an adequate temporary solution shall be used. This shall be reported to the owner of the equipment so that all parties are advised. Initial safety checks shall include:

- That capacitors are discharged: this shall be done in a safe manner to avoid the possibility of sparking;
- That no live electrical components and wiring are exposed while charging, recovering or purging the system;
- That there is continuity of earthing.

WARNING

Sealed electrical components shall be replaced.

Intrinsically safe components must be replaced.

Check that cabling will not be subject to wear, corrosion, excessive pressure, vibration, sharp edges or any other adverse environmental effects. The check shall also take into account the effects of aging or continual vibration from sources such as compressors or fans.

Under no circumstances shall potential sources of ignition be used while searching for or detection of refrigerant leaks. A halide torch (or any other detector using a naked flame) shall not be used.

Electronic leak detectors may be used to detect refrigerant leaks but, in the case of flammable refrigerants, the sensitivity may not be adequate, or may need re-calibration. (Detection equipment shall be calibrated in a refrigerant-free area.) Ensure that the detector is not a potential source of ignition and is suitable for the refrigerant used. Leak detection equipment shall be set at a percentage of the LFL of the refrigerant and shall be calibrated for the refrigerant employed, and the appropriate percentage of gas (25 % maximum) is confirmed.

If a leak is suspected, all naked flames shall be removed/extinguished.

If a leakage of refrigerant which requires brazing is found, all of the refrigerant shall be recovered from the system, or isolated (by means of shut off valves) in a part of the system remote from the leak.

Leak detection fluids are also suitable for use with most refrigerants but the use of detergents containing chlorine shall be avoided as the chlorine may react with the refrigerant and corrode the copper pipe-work.

NOTE: Examples of leak detection fluids are

- bubble method,
- fluorescent method agents.

When breaking into the refrigerant circuit to make repairs - or for any other purpose -conventional procedures shall be used. However, for flammable refrigerants it is important that best practice be followed, since flammability is a consideration. The following procedure shall be adhered to:

- safely remove refrigerant following local and national regulations.
- evacuate.
- purge the circuit with inert gas .
- evacuate.
- continuously flush or purge with inert gas when using flame to open circuit, and.
- open the circuit.

The refrigerant charge shall be recovered into the correct recovery cylinders if venting is not allowed by local and national codes. For appliances containing flammable refrigerants, the system shall be purged with oxygen-free nitrogen to render the appliance safe for flammable refrigerants. This process might need to be repeated several times. Compressed air or oxygen shall not be used for purging refrigerant systems.

For appliances containing flammable refrigerants, refrigerants purging shall be achieved by breaking the vacuum in the system with oxygen-free nitrogen and continuing to fill until the working pressure is achieved, then venting to atmosphere, and finally pulling down to a vacuum. This process shall be repeated until no refrigerant is within the system .When the final oxygen-free nitrogen charge is used, the system shall be vented down to atmospheric pressure to enable work to take place.

The outlet for the vacuum pump shall not be close to any potential ignition sources, and ventilation shall be available.

Ensure that contamination of different refrigerants does not occur when using charging equipment. Hoses or lines shall be as short as possible to minimize the amount of refrigerant they contain.

Cylinders shall be kept upright. Ensure that the refrigeration system is grounded prior to charging the system with refrigerant.

Label the system when charging is complete (if it is not already labeled).

Take extreme care not to overfill the refrigeration system.

Prior to recharging the system, it shall be pressure-tested with the appropriate purging gas. The system shall be leak-tested on completion of charging but prior to commissioning. A follow up leak test shall be carried out prior to leaving the site.

Before carrying out this procedure, it is essential that the technician is completely familiar with the equipment and all its detail. It is recommended that all refrigerants are recovered safely. Prior to the task being carried out, an oil and refrigerant sample shall be taken in case analysis is required prior to re-use of reclaimed refrigerant. It is essential that electrical power is available before the task is commenced.

- a) Become familiar with the equipment and its operation.
- b) Isolate system electrically.
- c) Before attempting the procedure ensure that:
 - mechanical handling equipment is available, if required, for handling refrigerant cylinders;
 - all personal protective equipment is available and being used correctly;
 - the recovery process is supervised at all times by a competent person;
 - recovery equipment and cylinders conform to the appropriate standards.
- d) Pump down refrigerant system, if possible.
- e) If a vacuum is not possible, make a manifold so that refrigerant can be removed from various parts of the system.
- f) Make sure that the cylinder is situated on the scales before recovery takes place.
- g) Start the recovery machine and operate it in accordance with the manufacturer's instructions.
- h) Do not overfill cylinders. (No more than 80% volume liquid charge).
- i) Do not exceed the maximum working pressure of the cylinder, even temporarily.
- j) When the cylinders have been filled correctly and the process has been completed, make sure that the cylinders and the equipment are removed from site promptly and all isolation valves on the equipment are closed off.
- k) Recovered refrigerant shall not be charged into another refrigeration system unless it has been cleaned and checked.

Equipment shall be labeled stating that it has been decommissioned and emptied of refrigerant. The label shall be dated and signed. Ensure that there are labels on the equipment stating the equipment contains flammable refrigerant.

When removing refrigerant from a system, either for servicing or decommissioning, it is recommended that all refrigerants are removed safely.

When transferring refrigerant into cylinders, ensure that only appropriate refrigerant recovery cylinders are employed. Ensure that the correct number of cylinders for holding the total system charge is available. All cylinders to be used are designated for the recovered refrigerant and labeled for that refrigerant (i.e. special cylinders for the recovery of refrigerant). Cylinders shall be complete with pressure-relief valve and associated shut-off valves in good working order. Empty recovery cylinders are evacuated and, if possible, cooled before recovery occurs.

The recovery equipment shall be in good working order with a set of instructions concerning the equipment that is at hand and shall be suitable for the recovery of the flammable refrigerant. If in doubt, the manufacturer should be consulted. In addition, a set of calibrated weighing scales shall be available and in good working order. Hoses shall be complete with leak-free disconnect couplings and in good condition.

The recovered refrigerant shall be processed according to local legislation in the correct recovery cylinder, and the relevant waste transfer note arranged. Do not mix refrigerants in recovery units and especially not in cylinders.

If compressors or compressor oils are to be removed, ensure that they have been evacuated to an acceptable level to make certain that flammable refrigerant does not remain within the lubricant. The compressor body shall not be heated by an open flame or other ignition sources to accelerate this process. When oil is drained from a system, it shall be carried out safely.

Do not use the air conditioner for other purposes. In order to avoid any quality deterioration, do not use the unit for the cooling of precision instruments, food, plants, animals or works of art. Before cleaning, be sure to stop the operation, turn the breaker off or unplug the supply cord. Otherwise, electric shock and injury may occur.

In order to avoid electric shock or fire, make sure that an earth leak detector is installed.

Never touch the air outlet or the horizontal blades while the swing flap is in operation. Your fingers may be caught or the unit may break down.

Never put any objects into the air inlet or outlet.

Objects touching the fan at high speed can be dangerous.

Never inspect or service the unit by yourself.

Ask a qualified service person to perform this task.

Do not dispose of this product as unsorted municipal waste. This waste should be collected separately for special treatment. Do not dispose of electrical appliances as unsorted municipal waste. Use separate collection facilities. Contact your local government for information regarding the connection systems available.

If electrical appliances are disposed of in landfills or dumps, hazardous substances can leak into the groundwater and get into the food chain, harming your health and well-being.

To prevent refrigerant leak, contact your dealer.

When the system is installed and operates in a small room, it is required to maintain the concentration of the refrigerant below the limit, in case a leak occurs. Otherwise, oxygen in the room may be affected, resulting in a serious accident.

The refrigerant in the air conditioner is safe and normally does not leak.

If the refrigerant leaks into the room and comes into contact with the fire of a burner, a heater or a cooker, a harmful gas could be released.

Turn off any combustible heating devices, ventilate the room, and contact the dealer where you purchased the unit.

Do not use the air conditioner until a service person confirms that the refrigerant leak is repaired.

Keep ventilation openings clear of obstruction.

CAUTION

Be sure the air conditioner is earthed.

In order to avoid electric shock, make sure that the unit is earthed and that the earth wire is not connected to a gas or water pipe, lightning conductor or telephone earth wire.

Do not operate the air conditioner with a wet hands. An electric shock may happen.

Do not touch the heat exchanger fins. These fins are sharp and could cut you.

To avoid oxygen deficiency, ventilate the room sufficiently if equipment with a burner is used together with the air conditioner.

Arrange the drain hose to ensure smooth drainage. Incomplete drainage may cause wetting of the building, furniture, etc.

Never touch the internal parts of the controller.

Do not remove the blower access panel. Some parts inside are dangerous to touch, and machine troubles may occur.

Attention is drawn to the fact that additional transportation regulations may exist with respect to equipment containing flammable gas. The maximum number of pieces of equipment or the configuration of the equipment permitted to be transported together will be determined by the applicable transport regulations.

Signs for similar appliances used in a work area are generally addressed by local regulations and give the minimum requirements for the provision of safety and/or health signs for a work location.

All required signs are to be maintained and employers should ensure that employees receive suitable and sufficient instruction and

training on the meaning of appropriate safety signs and the actions that need to be taken in connection with these signs.

The effectiveness of signs should not be diminished by too many signs being placed together.

Any pictograms used should be as simple as possible and contain only essential details.

The storage of the appliance should be in accordance with the applicable regulations or instructions, whichever is more stringent.

Storage package protection should be constructed such a way that mechanical damage to the equipment inside the package will not cause a leak of the REFRIGERANT CHARGE.

The maximum number of pieces of equipment permitted to be stored together will be determined by local regulations.

Do not operate the air conditioner when using a room fumigation - type insecticide. Failure to observe this precaution could cause the chemicals to become deposited in the unit, which could endanger the health of those who are hypersensitive to chemicals. It may also cause the refrigerant sensor to alarm.

Do not place appliances which produce open flame in places exposed to the air flow from the unit or under the indoor unit. It may cause incomplete combustion or deformation of the unit due to the heat.

Do not install the air conditioner in a location where flammable gas may leak out. If the gas leaks out and stays around the air conditioner, a fire may break out.

The appliance uses R454B refrigerant.



2 ABOUT THE PRODUCT

The coil can be positioned for bottom return air in the upflow and horizontal right applications. It must be positioned for top return when in downflow and horizontal left applications. See figure 2-1. For furnace applications, the coil must be installed downstream (in the air outlet) of the furnace

NOTE

This coil comes with a factory-installed heat shield on the drain pan.

2.1 Unit Dimensions

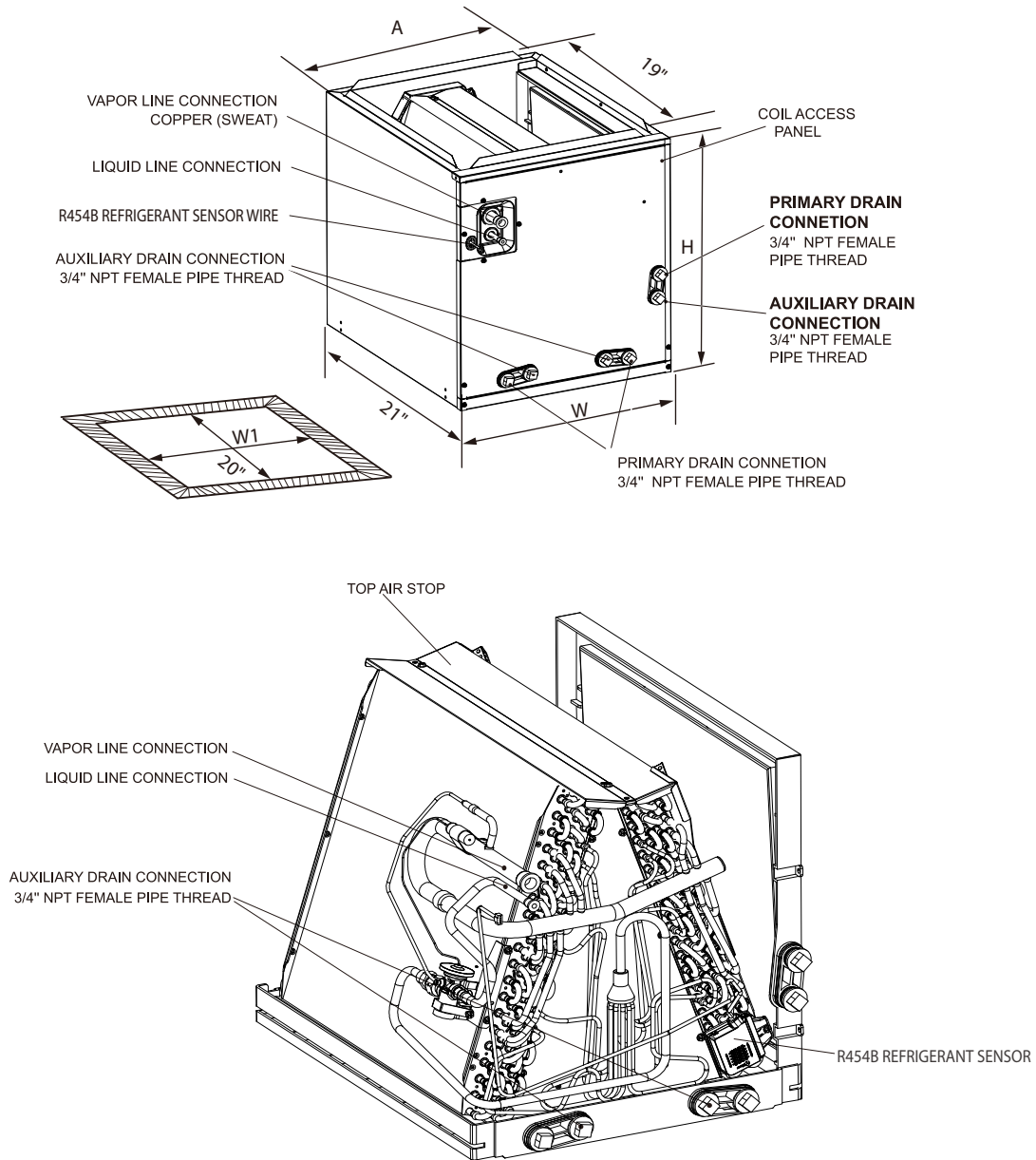

Fig. 2-1 CASED DIMENSIONS AND COMPONENT LOCATION

DIMENSIONAL DATA

MODELS	Unit Dimensions					WEIGHT (LBS.[kg])
	UNIT HEIGHT "H" IN. [mm]	UNIT WIDTH "W" IN. [mm]	SUPPLY DUCT "A" IN. [mm]	"W1" IN. [mm]	LIQUID LINE/ VAPOR LINE	
BZ33-XCCM3036A	20"[508]	14-1/2"[368]	13"[330]	13-1/2"[343]	3/8" / 3/4"	44[20]
BZ33-XCCM3036B	20"[508]	17-1/2"[445]	16"[407]	16-1/2"[419]	3/8" / 3/4"	46[21]
BZ33-XCCM3036C	20"[508]	21"[533]	19-1/2"[495]	20"[508]	3/8" / 3/4"	49[22]
BZ33-XCCM3642B	26"[660]	17-1/2"[445]	16"[407]	16-1/2"[419]	3/8" / 7/8"	57[26]
BZ33-XCCM3642C	26"[660]	21"[533]	19-1/2"[495]	20"[508]	3/8" / 7/8"	59[27]
BZ33-XCCM3642D	26"[660]	24-1/2"[622]	23"[584]	23-1/2"[597]	3/8" / 7/8"	64[29]
BZ33-XCCM4248B	30"[762]	17-1/2"[445]	16"[407]	16-1/2"[419]	3/8" / 7/8"	73[33]
BZ33-XCCM4248C	30"[762]	21"[533]	19-1/2"[495]	20"[508]	3/8" / 7/8"	73[33]
BZ33-XCCM4248D	30"[762]	24-1/2"[622]	23"[584]	23-1/2"[597]	3/8" / 7/8"	75[34]
BZ33-XCCM4860C	30"[762]	21"[533]	19-1/2"[495]	20"[508]	3/8" / 7/8"	81[37]
BZ33-XCCM4860D	30"[762]	24-1/2"[622]	23"[584]	23-1/2"[597]	3/8" / 7/8"	86[39]

Table 2-1

2.2 Codes & Regulations

This product is designed and manufactured to comply with national codes.

Installation in accordance with such codes and/or prevailing local codes/regulations is the responsibility of the installer. The manufacturer assumes no responsibility for equipment installed in violation of any codes or regulations.

The United States Environmental Protection Agency(EPA) has issued various regulations regarding the introduction and disposal of refrigerants. Failure to follow these regulations may harm the environment and can lead to the imposition of substantial fines. Should you have any questions please contact the local office of the EPA.

2.3 Inspection upon Unit Arrival

As soon as unit is received, it should be inspected and noted for possible shipping damage during transportation. It is carrier's responsibility to cover the cost of shipping damage. Manufacturer or distributor will not accept a claim from contractors for any transportation damage.

2.4 Clearances

Following clearances should be provided during installation

- a. Maintenance and service access, including coil cleaning and coil assembly removal
- b. Refrigerant piping and connections
- c. Condensate drain line

Ensure the proper installation, select a solid and level site.

Ensure enough space required for installation and maintenance.

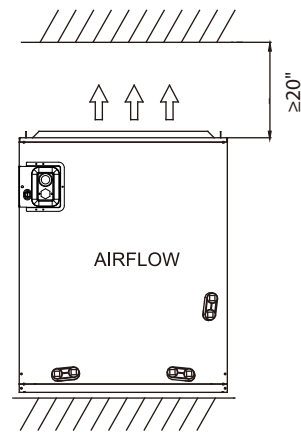

Fig. 2-2 Front view of the indoor unit clearance (including air duct)

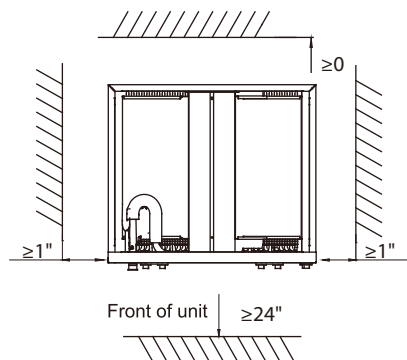

Fig. 2-3 Top View of the indoor unit clearance (including air duct)

2.5 Refrigerant Sensor

R454B refrigerant leakage sensor is configured for the indoor unit. To meet different installation scenarios, the refrigerant sensor is located in the bottom right corner of the Coil. Before installing the indoor unit, check whether the refrigerant sensor is correctly installed according to Section 3.

CAUTION

The refrigerant leakage sensor can only use the factory model or the specified model indicated in the corresponding manual.

The R454B refrigerant leakage sensor must be used to activate the refrigerant shut-off device, the alarm device, incorporated circulation airflow or other emergency controls, which shall give an electrical signal at a predetermined alarm set point in response to leaked refrigerant.

The location of leakage sensors shall be chosen in relation to the different installation scenarios. Please refer to the indoor unit installation manual for specific requirements.

The installation of the refrigerant leakage sensor shall allow access for checking, repair or replacement by an authorized person.

The refrigerant leakage sensor shall be installed so its function can be verified easily.

The refrigerant leakage sensor shall be protected to prevent tampering or unauthorized resetting of the pre-set value.

To be effective, the refrigerant leakage sensor must be electrically powered at all times after installation, other than when servicing.

If the refrigerant leakage sensor detects a refrigerant leak, the fan will be turned on to the maximum, the compressor will stop running. You should immediately leave the leak area and notify a professional for handling.

The service life of the refrigerant sensor is 15 years, and it should be replaced after the service life.

WARNING

LEAK DETECTION SYSTEM installed on indoor unit, unit must be powered except for service.

NOTE

R454B refrigerant leakage sensor is configure for the indoor unit, and the operation of fan can be initiated by R454B refrigerant sensor, meeting the incorporated circulation airflow requirements. The allowed maximum refrigerant charge(M_{max}) and the required minimum room area(A_{min}) can be determined according to Table 3-2 and Table 3-3.

3 INSTALLATION

3.1 Replacement Parts

Contact your distributor for authorized replacement parts.

3.2 Pre-installation Instruction

Carefully read all instructions for installation prior to installation product. Make sure each step or procedure is understood and any special considerations are taken into account before starting installation. Assemble all tools, hardware and supplies needed to complete the installation. Some items may need to be purchased locally.

Make sure everything needed to install the product is on hand before starting.

Do not install unit in an area where flammable materials are present due to the risk of an explosion resulting in serious injury or death.

WARNING

These instructions are exclusively intended for qualified contractors and authorized installers.

Work on the refrigerant circuit with flammable refrigerant in safety group A2L may only be carried out by authorized contractors. These heating contractors must be trained in accordance with UL 60335-2-40, Section HH. The certificate of competence from an industry accredited body is required.

Work on electrical equipment may only be carried out by a qualified electrician.

Before initial commissioning, all safety – related points must be checked by the particular certified heating contractors. The system must be commissioned by the system installer or a qualified person authorized by the installer.

For installation of the indoor unit, refer to the corresponding installation and operation manual. If an indoor unit is installed in an unventilated area, the area shall be so constructed that should any refrigerant leak, it will not stagnate so as to create a fire or explosion hazard.

The appliance shall be stored so as to prevent mechanical damage from occurring.

Do not stack combustible materials on the surface of the indoor unit.

WARNING

Ensure that apparatus is mounted securely.

3.3 Installation and Trap Connection

1. See Fig. 3-1 for coil installation and drain connection.
2. Installation steps for cased coil:
 - A. Shut off or disconnect gas furnace's power and remove gas pipe if necessary.
 - B. Disconnect and remove a sufficient portion of the supply ductwork to provide clearance for the cased coil.
 - C. Ensure that the coil is leveled well and seal the gap between coil and furnace. See Fig. 3-1. In case that coil and furnace sizes are not matched, use proper size of sheet metal or other material to fill the gap and seal the gap to prevent air leak.
 - D. Reconnect the ductwork to the coil case, and seal any leakage.
 - E. Reconnect Power line on gas furnace, turn on the furnace to check any sign of leakage.

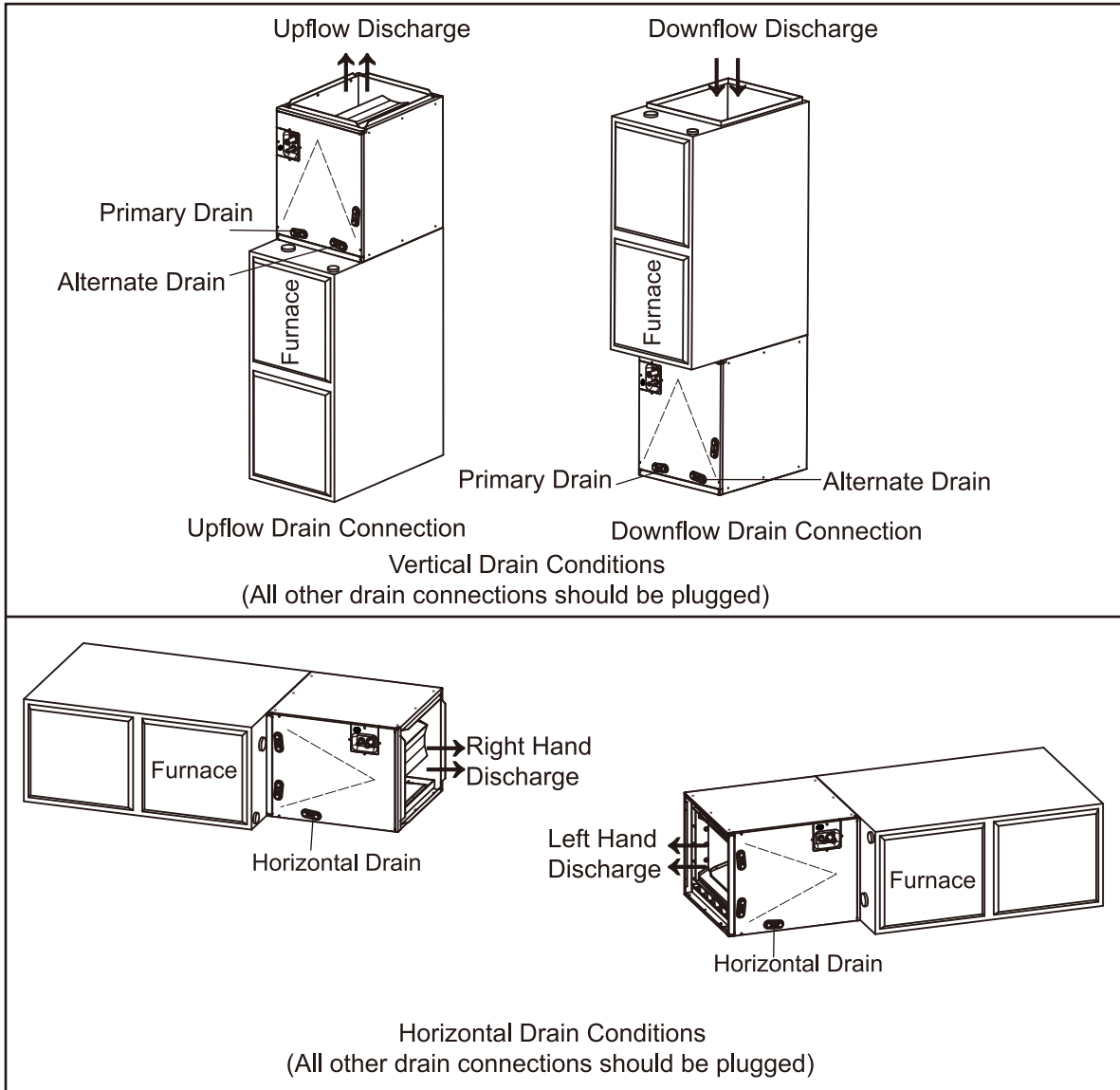

Fig. 3-1 INSTALLATION OF CASED COIL

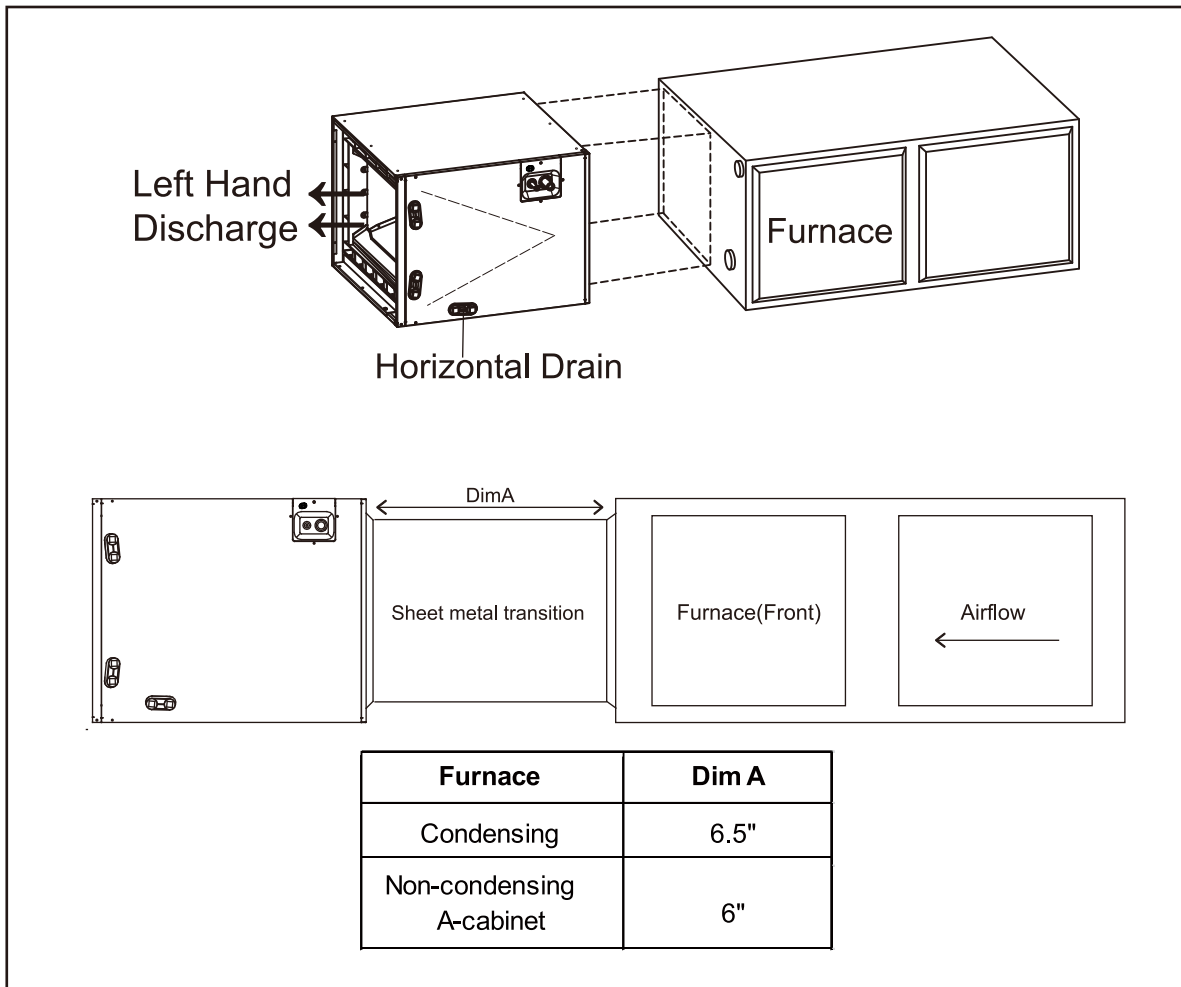

Fig. 3-2 Transition for horizontal left orientation

3. If the coil is used in connection with an upflow furnace in horizontal left orientation, a sheet metal transition can be installed between the furnace supply air outlet and the evaporator coil supply air inlet to create clearance between coil lineset and furnace flue outlet for A-cabinet non-condensing furnaces and for all cabinet size condensing furnaces. See Fig. 3-2

For A-cabinet non-condensing furnaces, a 6" transition is needed.

For all cabinet size condensing furnaces, a 6.5" transition is needed.

If space is a constraint, the lines/flue interference can be removed by rotating the coil such that the line set is facing the opposite direction and air flow through the bottom of the A-coil, thus optimizing airflow.

NOTE

Transition not needed with S-Series furnaces.

3.4 Installation of Refrigerant Sensor

The wire of the refrigerant sensor must be connected to the Kit. For specific operation instructions, please refer to the Wiring Diagrams and Explanatory label of KIT

WARNING

When using a gas furnace for heating, ensure that the outlet temperature does not exceed 200°F. Exceeding this temperature may cause the refrigerant leak sensor to malfunction, which can lead to a hazardous situation.

3.5 Refrigerant Charge and Room Area Limitations

In UL/CSA 60335-2-40, R454B refrigerant is classified as class A2L, which is mildly flammable. Therefore, R454B refrigerant is suitable for systems needing additional refrigerant charge and which will limit the area of the rooms being served by the system.

Similarly, the total amount of refrigerant in the system shall be less than or equal to the allowable maximum refrigerant charge. The allowable maximum refrigerant charge depends on the area of the rooms being served by the system.

NOTE

The nouns in this section are explained as follows:

Mc: The actual refrigerant charge in the system.

A: the actual room area where the appliance is installed.

Amin: The required minimum room area.

Mmax: The allowable maximum refrigerant charge in a room.

Qmin: The minimum circulation airflow.

Anvmin: The minimum opening area for connected rooms.

TAmin: The total area of the conditioned space (For appliances serving one or more rooms with an air duct system).

TA: The total area of the conditioned space connected by air ducts.

3.5.1 The room area calculation requirements

CAUTION

The space considered shall be any space which contains refrigerant-containing parts or into which refrigerant could be released.

The room area (A) of the smallest, enclosed, occupied space shall be used in the determination of the refrigerant quantity limits.

For determination of room area (A) when used to calculate the refrigerant charge limit, the following shall apply.

The room area (A) shall be defined as the room area enclosed by the projection to the base of the walls, partitions and doors of the space in which the appliance is installed.

Spaces connected by only drop ceilings, ductwork, or similar connections shall not be considered a single space.

Units mounted higher than 70-55/64 inches and spaces divided by partition walls that are no higher than 62-63/64 inches shall be considered a single space.

Rooms on the same floor and connected by an open passageway between the spaces can be considered a single room when determining compliance to Amin, if the passageway complies with all of the following.

- 1) It is a permanent opening.
- 2) It extends to the floor.
- 3) It is intended for people to walk through.

The area of the connected rooms, on the same floor, connected by permanent opening in the walls and/or doors between occupied spaces, including gaps between the wall and the floor, can be considered a single room when determining compliance to Amin, provided all of the following conditions are met as Fig. 3-13.

1) Low level opening

a. The opening shall not be less than Anvmin in Table 3-1.

b. The area of any openings above 11-13/16 inches from the floor shall not be considered in determining compliance with Anvmin.

c. At least 50% of the opening area of Anvmin shall be below 7-7/8 inches from the floor.

d. The bottom of the opening is not more than 3-15/16 inches from the floor.

e. The opening is a permanent opening that cannot be closed.

f. For openings extending to the floor the height shall not be less than 25/32 inches above the surface of the floor covering.

2) High level opening

a. The opening shall not be less than 50% of Anvmin in Table 3-1.

b. The opening is a permanent opening that cannot be closed.

c. The opening shall be at least 59 inches above the floor.

d. The height of the opening is not less than 25/32 inches.

3) Room size requirement

a. The room into which refrigerant can leak, plus the connected adjacent room(s) shall have a total area not less than Amin. Amin is shown in Table 3-3.

b. The room area in which the unit is installed shall be not less than 20% Amin. Amin is shown in Table 3-3.

NOTE

The requirement for the second opening can be met by drop ceilings, ventilation ducts, or similar arrangements that provide an airflow path between the connected rooms.

The minimum opening for natural ventilation (Anvmin) in connected rooms is related to the room area (A), the actual refrigerant charge of refrigerant in the system (Mc), and the allowable MAXIMUM REFRIGERANT CHARGE in the system (Mmax), Anvmin can be determined according to Table 3-1.

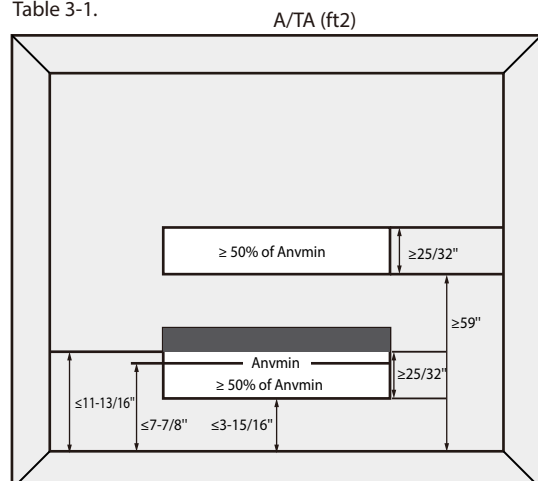

Fig. 3-3 Opening Conditions for Connected Rooms

The minimum opening area for connected rooms

A		Mc		Mmax		Anvmin	
ft ²	m ²	lb-oz	kg	lb-oz	kg	ft ²	m ²
100	11	17-3	7.8	6-10	3.0	1.3	0.14
110	12	17-3	7.8	7-5	3.3	1.2	0.13
120	13	17-3	7.8	8-0	3.6	1.1	0.12
130	14	17-3	7.8	8-10	3.9	1.0	0.11
140	16	17-3	7.8	9-5	4.2	1.0	0.11
150	17	17-3	7.8	10-0	4.5	0.9	0.10
160	18	17-3	7.8	10-10	4.8	0.8	0.09
170	19	17-3	7.8	11-5	5.1	0.7	0.08
180	20	17-3	7.8	12-0	5.4	0.6	0.07
190	21	17-3	7.8	12-10	5.7	0.5	0.06
200	22	17-3	7.8	13-5	6.0	0.5	0.06
210	23	17-3	7.8	14-0	6.4	0.4	0.04
220	24	17-3	7.8	14-10	6.6	0.3	0.03
230	26	17-3	7.8	15-5	6.9	0.2	0.02
240	27	17-3	7.8	16-0	7.3	0.1	0.01
250	28	17-3	7.8	16-10	7.5	0.1	0.01
260	29	17-3	7.8	17-5	7.9	0.0	0.00

Table 3-1

Note: Take the Mc=17 lbs 3 oz as an example.

For appliances serving one or more rooms with an air duct system, The room area calculation shall be determined based on the total area of the conditioned space (TA) connected by ducts taking into consideration that the circulating airflow distributed to all the rooms by the appliance integral indoor fan will mix and dilute the leaking refrigerant before entering any room.

3.5.2. Allowed maximum refrigerant charge and required minimum room area

If the fan incorporated to an appliance is continuously operated or operation is initiated by a REFRIGERANT DETECTION SYSTEM with a sufficient CIRCULATION AIRFLOW rate, the allowable maximum refrigerant charge (Mmax) and the required minimum room area (Amin/Tamin) is shown in Table 3-2 and Table 3-3.

The allowable maximum refrigerant charge

A/TA		Mmax		M/TA		Mmax	
ft ²	m ²	lb-oz	kg	ft ²	m ²	lb-oz	kg
30	3	2-0	1.8	150	17	10-0	10.0
40	4	2-10	2.6	160	18	10-10	10.6
50	6	3-5	3.3	170	19	11-5	11.3
60	7	4-0	4.0	180	20	12-0	12.0
70	8	4-10	4.6	190	21	12-10	12.6
80	9	5-5	5.3	200	22	13-5	13.3
90	10	6-0	6.0	210	23	14-0	14.0
100	11	6-10	6.6	220	24	14-10	14.6
110	12	7-5	7.3	230	26	15-5	15.3
120	13	8-0	8.0	240	27	16-0	16.0
130	14	8-10	8.6	250	28	16-10	16.6
140	16	9-5	9.3	260	29	17-5	17.3

Table 3-2

The required minimum room area

Mc		Amin/Tamin		Mc		Amin/Tamin	
lb-oz	kg	ft ²	m ²	lb-oz	kg	ft ²	m ²
2-2	1.0	33.1	3.1	10-2	4.6	152.1	14.1
2-9	1.2	39.7	3.7	10-9	4.8	158.7	14.7
3-0	1.4	46.3	4.3	11-0	5.0	165.3	15.4
3-7	1.6	52.9	4.9	11-7	5.2	171.9	16.0
3-15	1.8	59.5	5.5	11-14	5.4	178.5	16.6
4-6	2.0	66.1	6.1	12-5	5.6	185.1	17.2
4-13	2.2	72.7	6.8	12-12	5.8	191.7	17.8
5-4	2.4	79.3	7.4	13-3	6.0	198.4	18.4
5-11	2.6	86.0	8.0	13-10	6.2	205.0	19.0
6-2	2.8	92.6	8.6	14-1	6.4	211.6	19.7
6-9	3.0	99.2	9.2	14-8	6.6	218.2	20.3
7-0	3.2	105.8	9.8	14-15	6.8	224.8	20.9
7-7	3.4	112.4	10.4	15-6	7.0	231.4	21.5
7-15	3.6	119.0	11.1	15-14	7.2	238.0	22.1
8-6	3.8	125.6	11.7	16-5	7.4	244.6	22.7
8-13	.0	132.2	12.3	16-12	7.6	251.2	23.3
9-4	4.2	138.8	12.9	17-3	7.8	257.9	24.0
9-11	4.4	145.5	13.5				

Table 3-3

The minimum circulation airflow

Mc		Qmin		Mc		Qmin	
lb-oz	kg	CFM	m ³ /h	lb-oz	kg	CFM	m ³ /h
2-2	1.0	59	100	10-2	4.6	275	467
2-9	1.2	71	121	10-9	4.8	287	488
3-0	1.4	83	141	11-0	5.0	298	506
3-7	1.6	95	161	11-7	5.2	310	527
3-15	1.8	107	182	11-14	5.4	322	547
4-6	2.0	119	202	12-5	5.6	334	567
4-13	2.2	131	223	12-12	5.8	346	588
5-4	2.4	143	243	13-3	6.0	358	608
5-11	2.6	155	263	13-10	6.2	370	629
6-2	2.8	167	284	14-1	6.4	382	649
6-9	3.0	179	304	14-8	6.6	394	669
7-0	3.2	191	325	14-15	6.8	406	690
7-7	3.4	203	345	15-6	7.0	418	710
7-15	3.6	215	365	15-14	7.2	430	731
8-6	3.8	227	386	16-5	7.4	442	751
8-13	.0	239	406	16-12	7.6	454	771
9-4	4.2	251	426	17-3	7.8	466	792
9-11	4.4	263	447				

Table 3-4

⚠ CAUTION

The allowable maximum refrigerant charge of the Table 3-2 or the required minimum room area of the Table 3-3 is available only if the following conditions are met:

Minimum velocity of 3.28 ft/s, which is calculated as the indoor unit airflow divided by the nominal face area of the outlet. And the grill area shall not be deducted.

Minimum airflow rate must meet the corresponding values in Table 3-4, which is related to the actual refrigerant charge of the system (Mc).

R454B refrigerant leakage sensor is configured.

💡 NOTE

The maximum refrigerant limit described above applies to unventilated areas. If adding additional measures, such as areas with mechanical ventilation or natural ventilation, The maximum refrigerant charge can be increased or the minimum room area can be reduced.

R454B refrigerant leakage sensor is configured for the indoor unit, meets the incorporated circulation airflow requirements, the maximum refrigerant charge or minimum room area can be determined according to Table 3-2 or Table 3-3.

⚠ CAUTION

If the actual room area, air outlet height, and refrigerant charge amount are not reflected in the above table, more severe cases need to be considered according to the data in the table 3-1, 3-2, 3-3, 3-4.

● Installation scheme flow chart

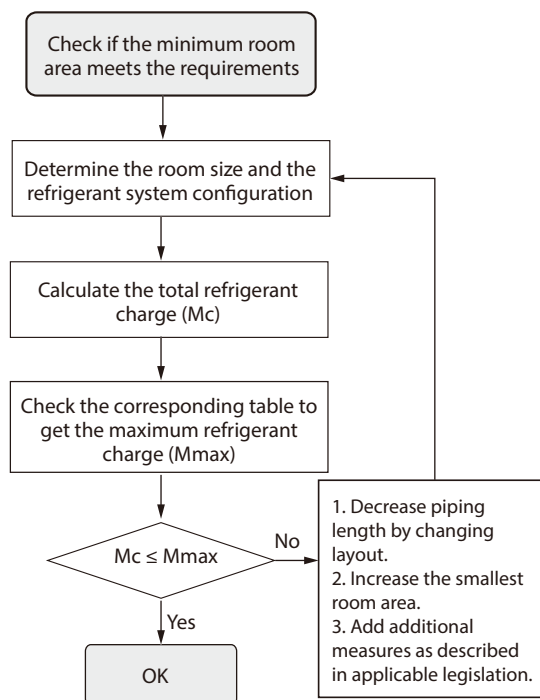

Fig. 3-4

4 REFRIGERANT LINE

The suction pipe and liquid pipe of the indoor unit need to be protected and cannot be grabbed when moving the indoor unit.

Keep the coil connections sealed until refrigerant connections are made. See the Installation Instructions for the outdoor unit for details on line sizing, tubing installation, and charging information.

Coil is shipped with Nitrogen. Evacuate the system before charging with refrigerant.

Install refrigerant tubing so that it does not block service access to the front of the unit.

Nitrogen should flow through the refrigerant lines while brazing.

Use a brazing shield to protect the cabinet's paint and a wet rag to protect the rubber grommet and TXV seal ring from being damaged by torch flames.

After the refrigerant connections are made, seal the gap around the connections with pressure sensitive gasket.

The pipe-work including piping material, pipe routing, and installation shall include protection from physical damage in operation and service, and be in compliance with national and local codes and standards, such as ASHRAE 15, ASHRAE 15.2, IAPMO Uniform Mechanical Code, ICC International Mechanical Code. Inspection prior to being covered or enclosed; or CSA B52. All field joints shall be accessible for inspection prior to being covered or enclosed.

All joints made in the installation between parts of the refrigerating system, with at least one part charged, shall be made in accordance with the following:

— A brazed, welded, or mechanical connection shall be made before opening the valves to permit refrigerant to flow between the refrigerating system parts. A vacuum valve shall be provided to evacuate the interconnecting pipe or any uncharged refrigerating system part.

— Mechanical connectors used indoors shall comply with ISO 14903. When mechanical connectors are reused indoors, sealing parts shall be renewed. When flared joints are reused indoors, the flare part shall be refabricated.

— Refrigerant tubing shall be protected or enclosed to avoid damage.

— Flexible refrigerant connectors (such as connecting lines between the indoor and outdoor unit) that may be displaced during normal operation shall be protected against mechanical damage.

Compliance is checked according to the installation instructions and a trial installation, if necessary.

Field-made refrigerant joints indoors shall be tightness tested. The test method shall have a sensitivity of 5 grams per year of refrigerant or better under a pressure of at least 0,25 times the maximum allowable pressure. No leak shall be detected.

After completion of field piping for split systems, the field pipework shall be pressure tested with an inert gas and then vacuum tested prior to refrigerant charging, according to the following requirements.

The minimum test pressure for the low side of the system shall be the low side design pressure and the minimum test pressure for the high side of the system shall be the high side design pressure, unless the high side of the system, cannot be isolated from the low side of the system in which case the entire system shall be pressure tested to the low side design pressure.

Field-made refrigerant joints indoors shall be tightness tested. The test method shall have a sensitivity of 5 grams per year of refrigerant or better under a pressure of at least 0.25 times the maximum allowable pressure. No leak shall be detected.

— mechanical joints in compliance with ISO 14903 or UL 207 (U.S. only).

— welded or brazed joints.

— joints in enclosures that vent to the unit or to the outside.

Compliance is checked by inspection and tests.

CAUTION

Use a wet rag to protect the two seal ring in the input pipe from being damaged by torch flames while brazing.

After the brazing work is finished, make sure to check if there is refrigerant leakage. After checking for vapor leaks, be sure to insulate the pipe connections referring.

NOTE

It is recommended to install a filter dryer, the filter drier should be installed in the liquid line between the outdoor unit's liquid line service valve and the indoor coil's metering device. The filter dryer should be compatible with R454B refrigerant.

5 DUCTWORK

Field ductwork must comply with the National Fire Protection Association NFPA 90A, NFPA 90B and any applicable local ordinance.

DANGER

Do not under any circumstances, connect return ductwork to any other heat producing device such as fireplace insert, stove, etc.

Unauthorized use of such devices may result in fire, carbon monoxide poisoning, explosion, personal injury or property damage.

Sheet metal ductwork in unconditioned spaces must be insulated and covered with a vapor barrier. Fibrous ductwork may be used if constructed and installed in accordance with SMACNA Construction Standard on Fibrous Glass Ducts. Ductwork must comply with National Fire Protection Association as tested by UL Standard 181 for Class I Air Ducts. Check local codes for requirements on ductwork and insulation.

- Duct system must be designed within the range of external static pressure the unit is designed to operate against. It is important that the system airflow be adequate. Make sure supply and return ductwork, grills, special filters, accessories, etc. are accounted for in total resistance.

- Design the duct system in accordance with "ACCA" Manual "D" Design for Residential Winter and Summer Air Conditioning and Equipment Selection. Latest editions are available from: "ACCA" Air Conditioning Contractors of America, 1513 16th Street, N.W., Washington, D.C. 20036. If duct system incorporates flexible air duct, be sure pressure drop information (straight length plus all turns) shown in "ACCA" Manual "D" is accounted for in the system.
- Supply plenum is attached to the 3/4" duct flanges supplied with the unit. Attach flanges around the blower outlet.

IMPORTANT: If an elbow is included in the plenum close to the unit, it can not be smaller than the dimensions of the supply duct flange on the unit.

IMPORTANT: The front flange on the return duct if connected to the blower casing must not be screwed into the area where the power wiring is located. Drills or sharp screw points can damage insulation on wires located inside unit.

Secure the supply and return ductwork to the unit flanges, using proper fasteners for the type of duct used and tape the duct-to-unit joint as required to prevent air leaks.

WARNING

If appliances connected via an air duct system to one or more rooms are installed in a room with an area less than shown in section 3.5 Table 3-3, that room shall be without continuously operating open flames (e.g. an operating gas appliance) or other potential ignition sources (for e.g. an operating electric heater, hot surfaces). A flame-producing device may be installed in the same space if the device is provided with an effective flame arrest.

For appliances connected via an air duct system to one or more rooms, auxiliary devices which may be a potential ignition source shall not be installed in the duct work. Examples of such potential ignition sources are hot surfaces with a temperature exceeding 1,292°F (700°C) and electric switching devices.

For appliances connected via an air duct system to one or more rooms, only auxiliary devices approved by the appliance manufacturer or declared suitable with the refrigerant shall be installed in connecting ductwork.

6 AIRFLOW PERFORMANCE

Airflow performance [CFM VS Pressure drop]

Pressure drop characteristics for cooling and heat pump coils								
Pressure drop (Inches of water)								
Model	0.05	0.1	0.15	0.2	0.25	0.3	0.35	0.4*
BZ33-XCCM3036A	307	485	618	729	823	911	991	1063
BZ33-XCCM3036B	327	527	682	810	925	1024	1122	1217
BZ33-XCCM3036C	360	585	748	893	1019	1132	1238	1348
BZ33-XCCM3642B	401	600	773	916	1045	1160	1256	1357
BZ33-XCCM3642C	457	663	856	1019	1156	1277	1394	1502
BZ33-XCCM3642D	496	718	924	1102	1259	1398	1530	1651
BZ33-XCCM4248B	456	638	810	953	1077	1191	1284	1390
BZ33-XCCM4248C	505	726	932	1098	1244	1375	1494	1604
BZ33-XCCM4248D	533	857	1105	1319	1509	1675	1824	1956
BZ33-XCCM4860C	439	699	906	1071	1224	1362	1487	1589
BZ33-XCCM4860D	466	764	978	1157	1313	1466	1590	1695

Table 6-1

Data based on wet coil with entering air at 80 deg F DB / 67 deg F WB without air filter.
The maximum allowable pressure drop is 0.4 in.WC.
The maximum CFM is the data at 0.4 in.WC pressure.

Maximum airflow setting

NOTE

Water blow-off could occur in certain installation positions if the airflow setting exceeds the maximum values listed.

NOTE

The air volume in the table represents the maximum allowed air volume. Because adjustment process of the constant air volume motor is fluctuate, so when A Coil is used with the constant air volume system, it is necessary to ensure that the maximum airflow during adjustment can't exceed the maximum airflow setting in table 7-2, otherwise it may lead to the phenomenon of blowing water.

Maximum airflow setting (CFM)				
Model	Upflow	Horizontal Left	Downflow	Horizontal Right
BZ33-XCCM3036A	1200	1050	1050	1200
BZ33-XCCM3036B	1250	1200	1050	1250
BZ33-XCCM3036C	1250	1200	1050	1250
BZ33-XCCM3642B	1575	1400	1400	1575
BZ33-XCCM3642C	1575	1400	1400	1575
BZ33-XCCM3642D	1575	1450	1450	1575
BZ33-XCCM4248B	1800	1800	1700	1500
BZ33-XCCM4248C	1800	1800	1700	1700
BZ33-XCCM4248D	1800	1800	1700	1700
BZ33-XCCM4860C	1850	1750	1750	1850
BZ33-XCCM4860D	2000	1850	1850	2000

Table 6-2

7 DRAIN APPLICATION

7.1 Condensate Drain Piping

Consult local codes for special requirements.

To provide extra protection from water damage, it is always recommended to install an additional drain pan, provided by installer under the entire unit with a separate drain line. Manufacturer will not be responsible for any damages due to the failure to follow these recommendations.

7.2 Drain Pan Installation

WARNING

Do not use the coil pan shipped with the unit on OIL furnaces or any application where the temperature of the drain pan may exceed 275°F. A field fabricated metal drain pan can also be used for these type of applications.

Failure to follow this warning may result in property damage and/or personal injury.

NOTE

Use Teflon tape on the drain line connections. Do not use pipe joint compound or PVC/CPVC cement on drain nipple.

The coil drain pan has a primary and an optional secondary drain with 3/4" NPT female connections; use either PVC or copper pipe and hand tighten to a torque of approximately 37 in-lbs. to prevent damage to the drain pan connection. An insertion depth between 0.355 to 0.485 inches (3-5 turns) should be expected at this torque setting.

Use male 3/4" NPT threaded fitting for outside connection and make sure the drain holes are not blocked.

Insulation may be needed for drain line to prevent sweating.

Drain pan has two drain connections on each side to provide flexibility of connection and drainage. Make sure pan has proper pitch and plugged if second connection is not used.

If the secondary drain line is required, run the line separately from the primary drain and terminate it where it can be easily seen.

NOTE

Water coming from this line means the coil primary drain is plugged and needs clearing.

Install a trap in the drain line below the bottom of the drain pan. If using a copper drain line, solder a short piece of pipe to the connector before installing a drain fitting. DO NOT over torque the 3/4" copper connector to the plastic drain connection. Use a wet rag or heatsink material on the short piece to protect plastic drain pan, complete the rag or heatsink material on the short piece.

To protect plastic drain pan, complete the drain line installation (Fig. 7-1). Use (Fig. 7-2) as a template for typical drain pipe routing.

This figure shows how to avoid interference with vent piping.

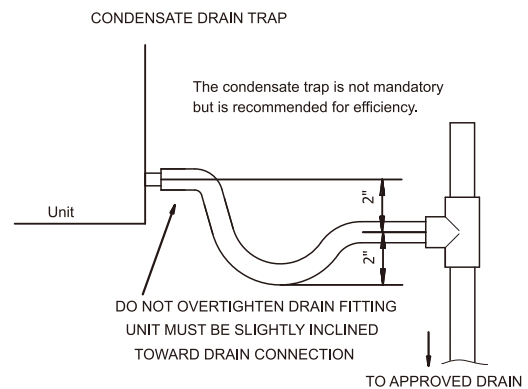

Fig. 7-1 DRAIN LINE INSTALLATION

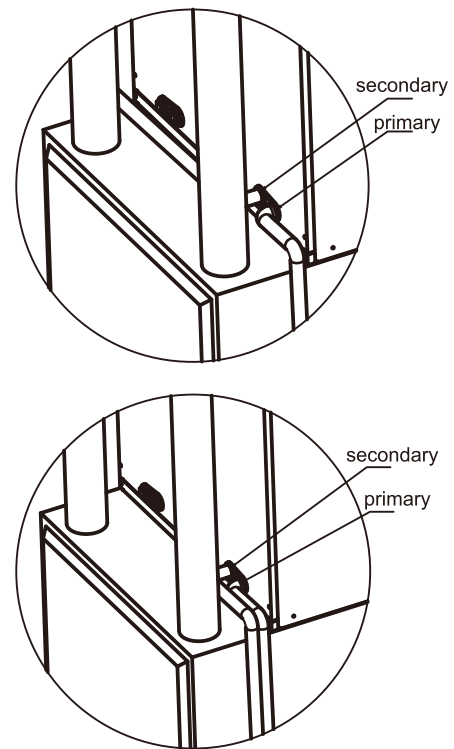

Fig. 7-2 DRAIN PIPE ROUTING

8 DISPOSAL

Comply with national regulations.

Components and accessories from the units are not part of ordinary domestic waste.

Complete units, compressors, motors etc. are only to be disposed of via qualified disposal specialists.

This unit uses flammable refrigerant R454B. Please contact the dealer when you want to dispose of this unit. Law requires that the collection, transportation and disposal of refrigerants must conform with the regulations governing the collection and destruction of hydrofluorocarbons.

TXV Replacement Information

NOTE: 1. This outdoor unit should be matched with indoor unit that has TXV or EXV for cooling.
 2. The TXV replacement options noted in this sheet supersede those in the installation guide. Please reference this sheet for all refrigerant metering options.

TXV-Replace Steps

- Step 1: Remove the screws and front coil panel.
- Step 2: Remove the rubber plugs from the liquid and vapor lines.
- Step 3: Unwrap copper strap on sensing bulb and dismount the sensing bulb.
- Step 4: Using a backup wrench to loose the nut of TXV.
- Step 5: Take off TXV mounting clip ring.
- Step 6: Use wet rag to protect pipe in coil, AI-Copper transition section (the black section of vapor line).
- Step 7: Braze and take off two pipes from TXV, Be extra care not to overheat the pipes.
- Step 8: Wrap the new TXV with a wet rag to prevent overheating. connect and braze pipe to new TXV. While brazing, use nitrogen flow and braze all connections.
- Step 9: Replace a new sealing ring to the pipe joint, connect the TXV with pipe joint and tight the nut to 30 ± 3 N.M.
- Step 10: Allow tube to cool and pressurize line sets with 150 PSI of nitrogen to check braze connections for leaks Make repairs if needed.
- Step 11: Use the supplied copper straps to secure the TXV sensing bulb on top of the vapor line as pictured.
- Step 12: Use clip ring to hold TXV on mounting plate.
- Step 13: Insulate the entire vapor line and sensing bulb. It is also recommended to insulate the TXV and liquid line to prevent condensation in hot humid environments.
- Step 14: Replace the front coil panel and secure in place.
- Step 15: Follow the steps in the installation guide for vacuum requirements and system start up procedures.
- Step 16: Allow system to run for an additional 10 minutes to verify the subcooling and superheat readings.

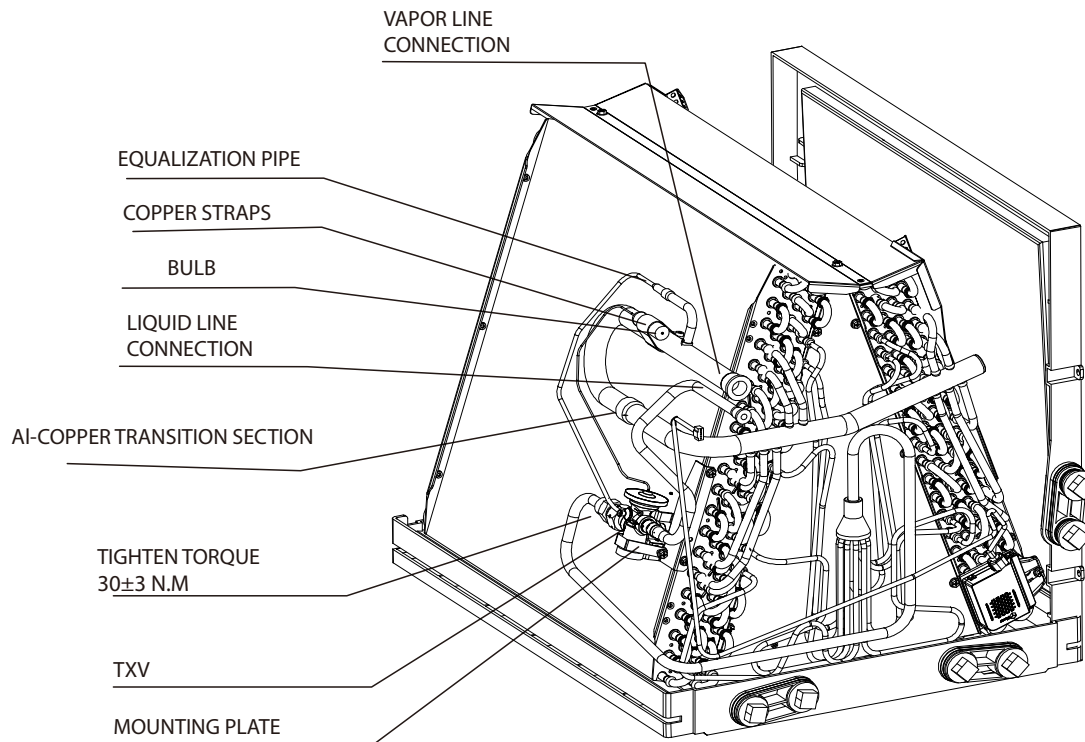

TXV kit part numbers list.

CAUTION

Please use a new outer O-ring that comes with the machine, which meet the ISO 14903 certification. Otherwise, there is a risk of refrigerant leakage and causing danger.

MODEL	R454B TXV Kit
3036, 3642	3 TON
4248	4 TON
4860	5 TON

**SCAN QR CODE TO LEARN MORE
ABOUT THE WARRANTY**



