



325 COMMERCE DRIVE
 MT VERNON, OH 43050
 800-253-8236

SPECIFICATION DATA SHEET

DATE: 3-28-13
 PREPARED BY: RL

PAGE: 1

MODEL NO. 8431

SPIRAL TAPERED REDUCER W/O CRIMP
 STANDARD MODEL

DIMENSIONS

SIZE	A	B	C	D	E	Gauges Avail.
6X4	6"	2 1/4"	4"	2 1/4"	6 1/2"	24,26
6X5	6"	2 1/4"	5"	2 1/4"	6 1/2"	24,26
8X6	8"	2 1/4"	6"	2 1/4"	6 1/2"	24,26
8X7	8"	2 1/4"	7"	2 1/4"	6 1/2"	24,26
9X7	9"	2 1/4"	7"	2 1/4"	6 1/4"	24,26
10X6	10"	2 1/4"	6"	2 1/4"	8"	24,26
10X7	10"	2 1/4"	7"	2 1/4"	8"	24,26
10X8	10"	2 1/4"	8"	2 1/4"	7"	24,26
12X6	12"	2 1/4"	6"	2 1/4"	9"	24,26
12X8	12"	2 1/4"	8"	2 1/4"	8"	24,26
12X10	12"	2 1/4"	10"	2 1/4"	7"	24,26
14X8	14"	2 1/4"	8"	2 1/4"	9"	24,26
14X10	14"	2 1/4"	10"	2 1/4"	8"	24,26
14X12	14"	2 1/4"	12"	2 1/4"	7"	24,26
14X6	14"	2 1/4"	6"	2 1/4"	10 5/8"	24,26
14X8	14"	2 1/4"	8"	2 1/4"	9"	24,26
16X8	16"	2 1/4"	8"	2 1/4"	10 5/8"	24,26
16X10	16"	2 1/4"	10"	2 1/4"	9"	24,26
16X12	16"	2 1/4"	12"	2 1/4"	8"	24,26
16X14	16"	2 1/4"	14"	2 1/4"	7"	24,26
18X6	18"	2 1/4"	6"	2 1/4"	14 1/4"	24,26
18X10	18"	2 1/4"	10"	2 1/4"	10 5/8"	24,26
18X12	18"	2 1/4"	12"	2 1/4"	9"	24,26
18X14	18"	2 1/4"	14"	2 1/4"	8"	24,26
18X16	18"	2 1/4"	16"	2 1/4"	7"	24,26
20X8	20"	2 1/4"	8"	2 1/4"	14 1/4"	24
20X10	20"	2 1/4"	10"	2 1/4"	13"	24
20X12	20"	2 1/4"	12"	2 1/4"	10 5/8"	24

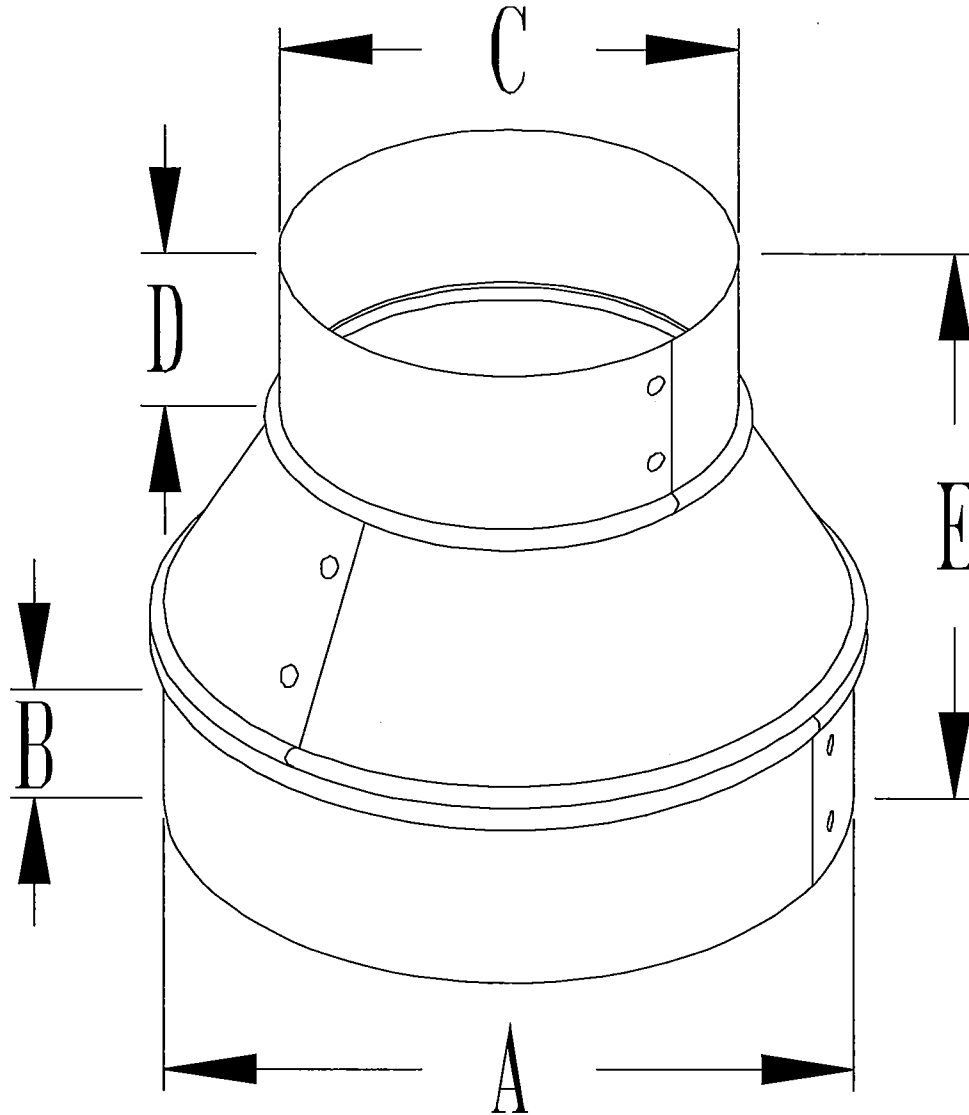

MATERIAL SPECIFICATIONS

HOT DIPPED GALVANIZED STEEL.
 PER ASTM A 653 CSB.

HEAVY GAUGE CONSTRUCTION

ASSEMBLED WITH 1/8" ZINC COATED RIVETS.

OPTIONS

JOB: _____
 LOCATION: _____
 CONTRACTOR: _____
 ENGINEER: _____
 NOTES: _____



325 COMMERCE DRIVE
 MT VERNON, OH 43050
 800-253-8236

SPECIFICATION DATA SHEET

DATE: 3-28-13
 PREPARED BY: RL

PAGE: 2

MODEL NO. 8431

SPIRAL TAPERED REDUCER W/O CRIMP
 STANDARD MODEL

DIMENSIONS

SIZE	A	B	C	D	E	Gauges Avail.
20X14	20"	2 1/4"	14"	2 1/4"	9"	24
20X16	20"	2 1/4"	16"	2 1/4"	8"	24
20X18	20"	2 1/4"	18"	2 1/4"	7"	24
22X10	22"	2 1/4"	10"	2 1/4"	14 1/2"	24
22X12	22"	2 1/4"	12"	2 1/4"	14 1/2"	24
22X14	22"	2 1/4"	14"	2 1/4"	10 5/8"	24
22X16	22"	2 1/4"	16"	2 1/4"	9"	24
22X18	22"	2 1/4"	18"	2 1/4"	7 3/4"	24
22X20	22"	2 1/4"	20"	2 1/4"	7"	24
24X14	24"	2 1/4"	14"	2 1/4"	13"	24
24X16	24"	2 1/4"	16"	2 1/4"	10 5/8"	24
24X22	24"	2 1/4"	22"	2 1/4"	7"	24
24X18	24"	2 1/4"	18"	2 1/4"	9"	24
24X20	24"	2 1/4"	20"	2 1/4"	4"	24
26X22	26"	2 1/4"	22"	2 1/4"	8 1/4"	24
26X20	26"	2 1/4"	20"	2 1/4"	9 1/2"	24
26X24	26"	2 1/4"	24"	2 1/4"	7"	24
28X14	28"	2 1/4"	14"	2 1/4"	14"	24
28X20	28"	2 1/4"	20"	2 1/4"	10 5/8"	24
28X22	28"	2 1/4"	22"	2 1/4"	9"	24
28X24	28"	2 1/4"	24"	2 1/4"	8"	24
28X26	28"	2 1/4"	26"	2 1/4"	7 1/4"	24
30X24	30"	2 1/4"	24"	2 1/4"	9"	24
30X26	30"	2 1/4"	26"	2 1/4"	8"	24
30X28	30"	2 1/4"	28"	2 1/4"	7 1/4"	24
32X26	32"	2 1/4"	26"	2 1/4"	9"	24

MATERIAL SPECIFICATIONS

HOT DIPPED GALVANIZED STEEL.
 PER ASTM A 653 CSB.

HEAVY GAUGE CONSTRUCTION

ASSEMBLED WITH 1/8" ZINC COATED RIVETS.

OPTIONS

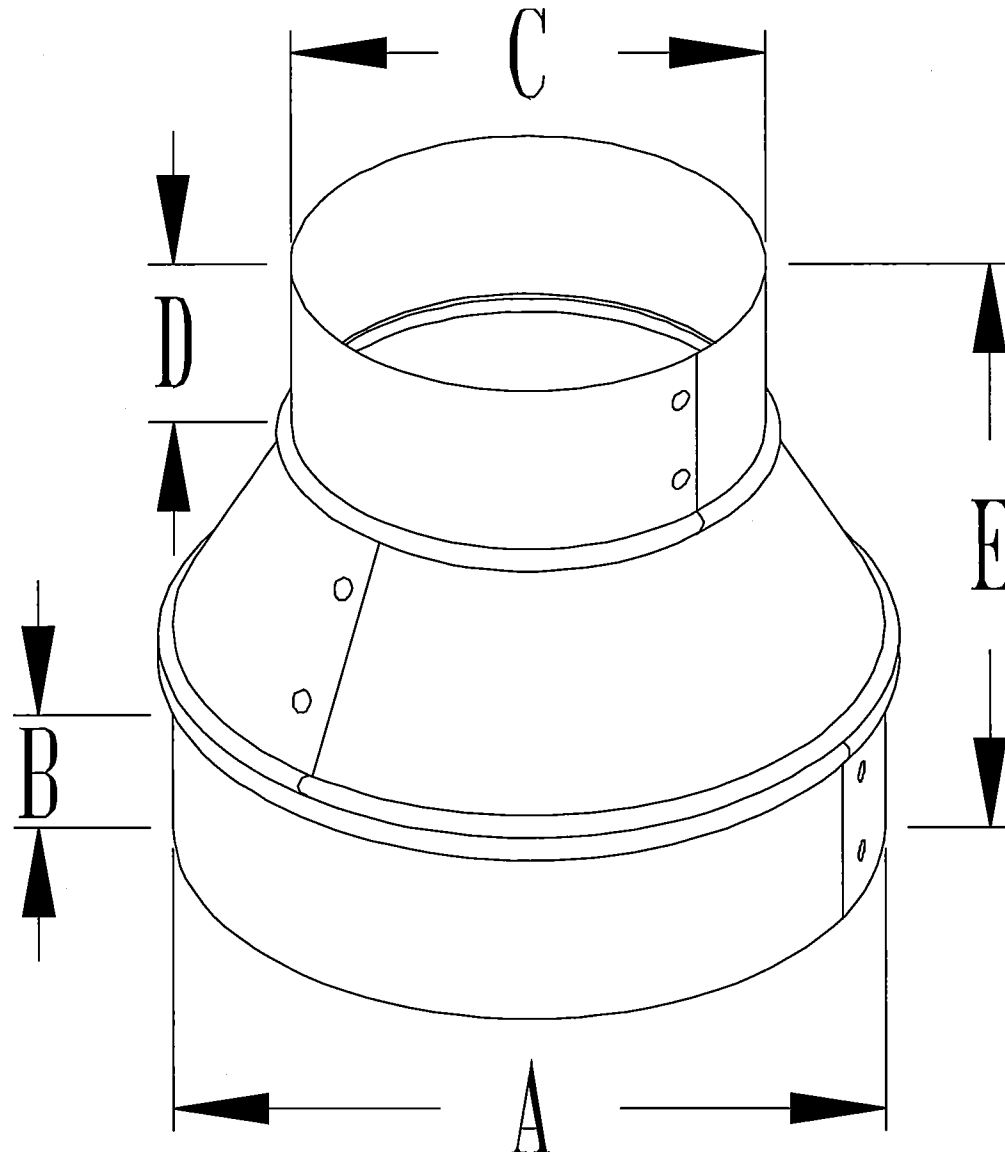

JOB: _____
 LOCATION: _____
 CONTRACTOR: _____
 ENGINEER: _____
 NOTES: _____