

# Joint I/Q Mixer and Filter Imbalance Compensation and Channel Equalization with Novel Preamble Design

Ramya Lakshmanan  
ramya.lakshmanan4@gmail.com

San Diego State University

fred harris  
fred.harris@sdsu.edu

## Abstract

In this paper, we consider the problem of analog signal imbalances between I- and Q- branches of the modulator/demodulator in OFDM systems. A novel compensation approach is proposed to solve this problem using baseband processing techniques, allowing for flexible RF design for high speed wireless systems. In particular, the proposed solution models transmitter and receiver impairments due to mixer and filter imbalances observed through channel related distortions. The solution is obtained by joint estimation and compensation of I/Q imbalance caused by the above impairments. The problem is studied for an OFDM wireless system and an analytical solution is presented in this paper. A novel preamble design is proposed to enable reliable estimation of the solution. Performance evaluations using MATLAB simulations are presented to confirm the effectiveness of the proposed method under various scenarios.

## 1. Introduction

Precise RF components play a vital role in high quality signal transmission and reception at high data rates. Moreover, flexibility in reconfiguring these RF components is desirable in order to support multiple modes of communication that is typical in modern systems. Mismatches in analog signal conditioning blocks due to manufacturing tolerances, component aging, or temperature changes can lead to signal impairments such as phase offset, frequency offset, I/Q imbalance etc. These mismatches lead to corruption of the received signal quality which reduce demodulation performance at the receiver. As data rates and frequency of operation increase, obtaining analog components required for reliable transmission is challenging. Digital signal processing techniques offer cost effective methods to overcome impairments due to the non-ideal RF components.

Low-IF architectures use quadrature mixing which in theory provides perfect image rejection. In practice there are always imbalances in the analog front or back ends due to finite tolerance of analog components implementing those analog signal conditioning blocks. Imbalance between I- and Q- processing paths lead to the formation of image signals which contaminate desired signal components during up or down-conversion. Compensating these mismatches using signal processing techniques results in flexible cost-efficient

designs. In this paper, we examine and correct I-Q imbalance in both transmitter and receiver along with the distorting propagation channel. A joint compensation technique is proposed that estimates the effect of a variety of analog transmitter and receiver imbalance parameters and compensate for them along with equalization of the channel to facilitate reliable demodulation of transmitted information. In Section 2, we provide a brief description of the problem of I-Q imbalance and its impact on OFDM transceivers. In Section 3, we present the proposed joint estimation and compensation technique, followed by analysis and the new preamble design. In Section 4, we present simulation results for the proposed techniques. In Section 5, we provide a conclusion to the thesis along with an overview of potential future work.

## 2. I/Q Imbalance in Digital Modulation

Digital modulation schemes are widely used in today's communication systems, typically in conjunction with OFDM (Orthogonal Frequency Division Multiplexing) for wideband transmission. In this paper, we base our studies on OFDM based communication systems that employ digital QAM modulation/demodulation. In order to use the bandwidth more efficiently, I/Q modulation schemes use the same bandwidth twice by modulating on two orthogonal carriers, namely a sine and a cosine carrier. At the receiver we need to separate them in order to decode both the signals. Small differences in phase or amplitude between I & Q path can cause imbalance, significantly impacting the quality demodulation. We model and describe imbalance in the communication system as (a) frequency independent Mixer imbalance and (b) frequency dependent Filter imbalance. Mixers cause imbalance due to phase and gain differences in the two paths. In the following characterization, shown in Figure 1, the imbalance in the phase at the transmitter and receiver are modelled as  $\alpha$  and  $\epsilon$ . In the ideal case, the phase imbalance coefficients are  $\alpha$  and  $\epsilon = 0$ . The gain imbalance at the transmitter and receiver are modelled as  $\beta$  and  $\delta$ , whereas in the ideal case  $\beta$  and  $\delta = 0$ .

### 2.1 Impact of receiver I-Q Mixer Imbalance

The transmitted waveform from the balanced up-converted modulator is modelled as follows:

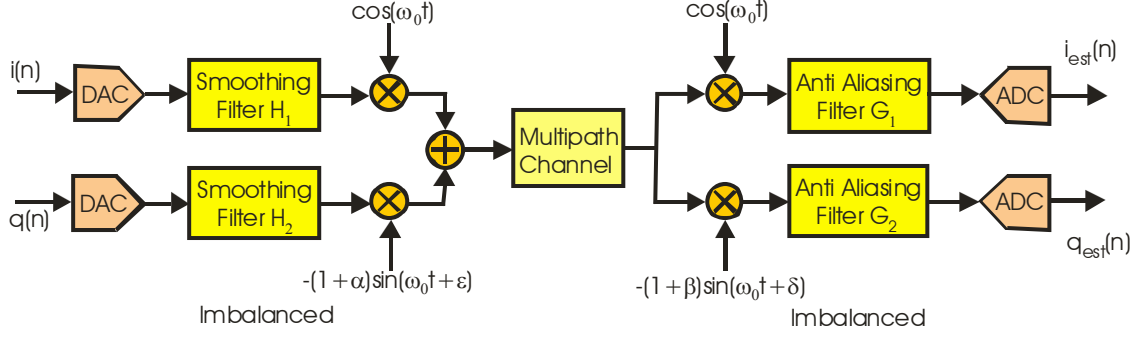

Figure 1. Imbalanced I-Q mixing and filter at Transmitter and Receiver

$$\begin{aligned}
 m_{Trans}(t) &= \text{Re}\{[x(t) + jy(t)][\cos(\omega_0 t) + j \sin(\omega_0 t)]\} \\
 M_{Trans}(\omega) &= \text{Re}\{\text{conv}[X(\omega) + jY(\omega), \exp(j\omega_0 t)]\} \\
 &= \text{Re}\{X(\omega - \omega_0) + jY(\omega - \omega_0)\} \\
 &= [X(\omega - \omega_0) + jY(\omega - \omega_0)] + [X^*(\omega + \omega_0) - jY^*(\omega + \omega_0)]
 \end{aligned} \tag{1}$$

The transmitted waveform from the unbalanced up-converted modulator is modelled as follows:

$$\begin{aligned}
 m_{Trans}(t) &= \text{Re}\{[x(t) + jy(t)][\cos(\omega_0 t) + j(1 + \alpha) \sin(\omega_0 t + \epsilon)]\} \\
 &= \text{Re}\{[x(t) + jy(t)][\cos(\omega_0 t) + j(1 + \alpha) \cos(\epsilon) \sin(\omega_0 t) + \sin(\epsilon) \cos(\omega_0 t)]\} \\
 &\cong \text{Re}\{[x(t) + jy(t)][\cos(\omega_0 t) + j \sin(\omega_0 t)] + \text{Re}\{[x(t) + jy(t)][j\epsilon \cos(\omega_0 t) + j\alpha \sin(\omega_0 t)]\}
 \end{aligned} \tag{2}$$

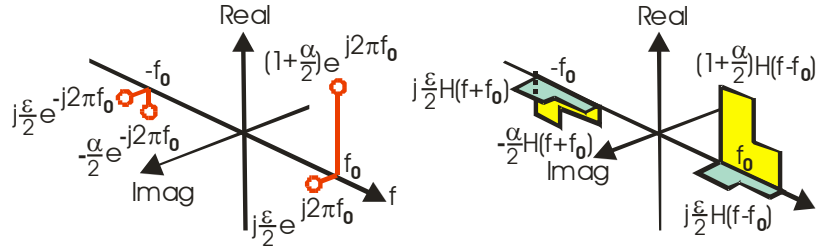

Figure 2. New spectral terms introduced due to imbalance in I-Q mixing

As seen from the third line of (2), the signal from the imbalanced up converter contains the desired complex heterodyned term of the first line of (1) but it also contains a  $j$ -cosine heterodyned term from the  $\alpha$  phase imbalance term and a  $j$ -sin heterodyned term from the  $\epsilon$  gain imbalance term. The spectrum of the imbalanced complex sinusoid is shown in figure 2 along with the spectral shift of the complex baseband signal formed by the heterodyne with the imbalanced sinusoid. The imbalance is seen to be responsible for an in-phase and a quadrature non-conjugate spectral image at the negative frequencies and for a quadrature image at the positive frequencies. For an example, due to the imbalance, information sent by an OFDM frequency tone  $+f$  leaks from the in-phase to the quadrature phase at the same frequency as well as from the  $+f$  frequency into its mirror image frequency  $-f$ . The amplitude of the leakage

terms are half the amplitude of the gain and phase imbalance terms. Similarly signal tones on the negative frequency axis will leak from  $-f$  to  $+f$ . This crossover leakage will severely degrade demodulation of high density constellations. The crossover terms we described and illustrated in figure 2 for the up-conversion imbalance have a companion harmful effect in the imbalanced down-conversion process.

## 2.2 Impact of Filter I-Q Imbalance

Another source of imbalance is filter imbalance that is caused by frequency dependent gain and phase difference of the analog filters in I and Q branches. The cosine and sine heterodynes move their shifted spectra through the in-phase filter  $H_I(f)$  and the quadrature filter  $H_Q(f)$  respectively. Gain and phase differences at any frequency contribute images at that frequency of the form

illustrated on the right side of Figure 2. In a manner identical to that shown in Figure 2, the transfer function of the positive frequency spectrum is formed by the sum of the positive frequency segments  $[H_I(+f)+H_Q(+f)]/2$  along with image response formed by the difference of the negative frequency segments  $[H_I(-f)-H_Q(-f)]/2$ . In the ideal case,  $H_I(f) = H_Q(f)$  which would cause the difference term to vanish. In the real world the analog filters on I & Q branches are not exactly same which leads to frequency dependent image terms due to the filter imbalance transfer function.

We now illustrate the effect of filter imbalance. To best show the image effect we consider a case where an OFDM signal set is confined to positive frequencies. In this simulation, there is no contribution due to channel effects and the I-Q mixers at both modulator and demodulator are ideal. Further, the filters at the transmitter are ideal and only the receiver filters are imbalanced. The imbalance is simulated by setting the pass-band frequency edge of the I-path filter to be one-percent higher

than the pass band frequency edge of the Q-path filter. The Matlab calls to the filter design files are shown in (3)

$$[bb1, aa1] = \text{cheby1}(5, 0.1, 20.2/50); \quad (3)$$

$$[bb2, aa2] = \text{cheby1}(5, 0.1, 20.0/50);$$

In figure 3, we see that the down converted positive frequency spectrum with filter imbalance produces negative frequency images. Overlaid on the signal spectrum are the frequency responses of the equivalent sum and difference filters

The key difference with filter imbalance compared to mixer imbalance is that the amplitude of the mirror images is frequency selective with filter imbalance while mixer imbalance does not produce frequency selective mirror images.

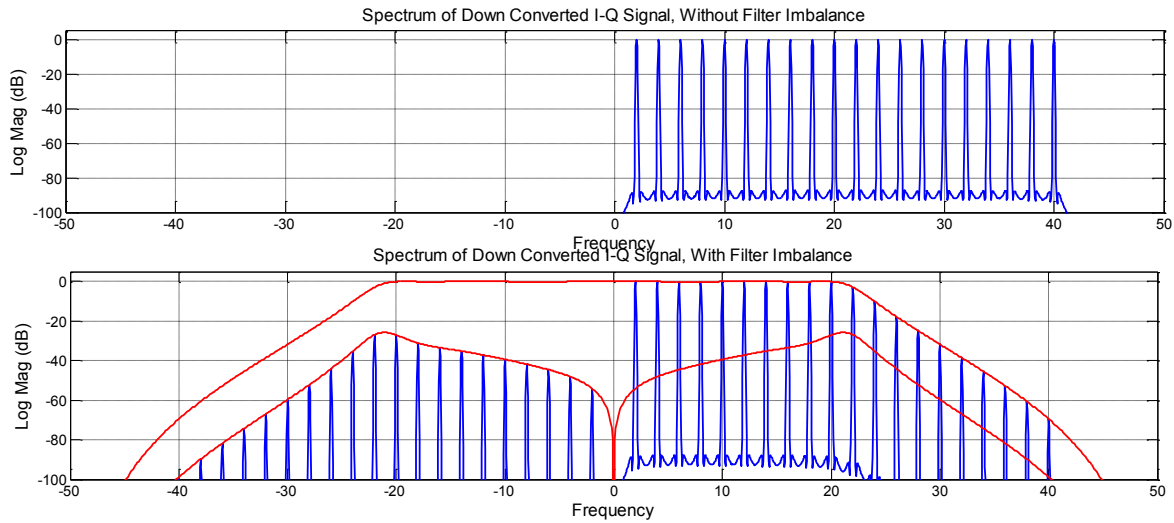

Figure 3. New spectral terms introduced due to imbalance in I-Q Filters

### 3. Joint Modelling of Impairments

Let the transmitted symbol on the  $k$ -th tone be  $X(k)$ , randomly chosen from an M-QAM constellation. The OFDM IFFT output is converted to an analog representation by a pair of DACs and passed through a pair of low pass filters to remove higher frequency spectral components. The output of the filtering operation is followed by an I-Q up conversion of the complex baseband signal. The output of the transmitted signal is convolved with channel response. The received signal is down converted by an I-Q down conversion and filtered by a pair of low-pass filters to limit the out of band signal bandwidth. The analog I-Q signals are converted to their digital representation by a pair of ADCs.

In order to consider imbalance scenario, the transmitter and receiver mixers are assumed to be imbalanced by  $\alpha$  and  $\epsilon$  and the  $b$  and  $d$  terms described earlier. Recall that  $\alpha$  and  $b$  indicate gain imbalance in the mixers while  $\epsilon$  and  $d$  indicates phase imbalance in the mixers. The input to the modulator mixers are filtered by the imbalanced smoothing filters and the output of the demodulator mixers are filtered by the imbalanced anti-aliasing filters. Differences in the modulator and demodulator filter pairs lead to imbalances that cause spectral cross-talk images from positive tone ( $k$ ) to negative tone ( $-k$ ). To remove the cross talk, symbol detection is performed by jointly considering the positive and negative tones. After simplifications of the transmit, receive equations, the received signal on the  $k^{\text{th}}$  and  $-k^{\text{th}}$  tone can be written as

$$\begin{bmatrix} Z(k) \\ Z^*(-k) \end{bmatrix} = \begin{bmatrix} X(k) & X^*(-k) & iX(k) & iX^*(-k) \\ X^*(-k) & X(k) & -iX^*(-k) & -iX(k) \end{bmatrix} \begin{bmatrix} P(k) \\ Q(k) \\ R(k) \\ S(k) \end{bmatrix} \quad (4)$$

where  $P(k)$ ,  $Q(k)$ ,  $R(k)$  and  $S(k)$ , are functions of the filter and mixer imbalance parameters at transmitter and receiver as well as the channel coefficients.

### 3.1 Estimation of Impairments

In normal OFDM we use a preamble to probe the channel to determine its frequency response. This response is used to invert the distortion induced by the channel. We extend this concept, using preambles to probe the I-Q filter and mixer distortion terms as well as the channel distortion terms. As seen from (4), there are 4 unknowns representing the mixer and filter I/Q imbalances. The unknowns represent the parameters of filter, channel and mixer imbalances. In order to estimate the unknowns, four equations are solve to solve for these parameters and two preambles are sufficient to supply the four equations. Thus, we propose the following dual preamble structure:



Figure 4. Dual Preamble Structure

Considering a second preamble  $V$ , in addition to  $X$  in (2), the estimate of the coefficients is obtained by simply inverting the matrix in the above equation, yielding the following:

$$\begin{bmatrix} P(k) \\ Q(k) \\ R(k) \\ S(k) \end{bmatrix} = \begin{bmatrix} X(k) & X^*(-k) & iX(k) & iX^*(-k) \\ X^*(-k) & X(k) & -iX^*(-k) & -iX(k) \\ V(k) & V^*(-k) & iV(k) & iV^*(-k) \\ V^*(-k) & V(k) & -iV^*(-k) & -iV(k) \end{bmatrix}^{-1} \begin{bmatrix} Z(k) \\ Z^*(-k) \\ A(k) \\ A^*(-k) \end{bmatrix} \quad (5)$$

where  $Z(k)$  and  $A(k)$  are the corresponding received symbols for the first and second preamble. The assumption here is that the channel and impairments stay constant over consecutive preamble symbols. The conditions for the 2 preamble design to work are

**Matrix inverse in the estimation should exist.**  
**In order for this to be true,  $X(k)V^*(-k) \neq X^*(-k)V(k)$**   
*(from the determinant of 4x4 matrix)*

With the above estimation, only the joint Tx/Rx filter response, I/Q leakage and channel can be estimated. The Tx and Rx I/Q leakage are not estimated separately.

### 3.2 Compensation of Estimated Impairments

The vector of outputs at  $k^{\text{th}}$  and  $-k^{\text{th}}$  tones is a linear function of the vector of inputs at  $k^{\text{th}}$  and  $-k^{\text{th}}$  tones. Therefore, the estimation and compensation are linear operations on the tone pair as opposed to just a per-tone operation.

$$\begin{bmatrix} Z(k) \\ Z^*(-k) \end{bmatrix} = \begin{bmatrix} P(k) + iR(k) & Q(k) + iS(k) \\ Q(k) - iS(k) & P(k) - iR(k) \end{bmatrix}^{-1} \begin{bmatrix} X(k) \\ X^*(-k) \end{bmatrix} \quad (6)$$

With the above estimation, only the joint Tx/Rx filter response, I/Q leakage and channel can be estimated. The Tx and Rx I/Q leakage are not estimated separately.

## 4. Simulation Results

In this section, we present simulation results for the proposed joint estimation and compensation scheme. An OFDM system with NFFT= 1024 is considered with a CP length of 128. At both Tx and Rx, a pair of low pass Chebyshev filters is used, with filter order of 5 and stop-band attenuation of 60dB. The filter offset between I & Q branch is 10% offset in the amplitude and 10% offset in the phase of the Q-component of the mixer. Also, a 10% mismatch in the filter bandwidth is considered. Both AWGN and frequency selective channel are considered. When a frequency selective channel is used for evaluations, its impulse response is

$$[1 \ 0 \ 0.3i \ 0.1i \ 0.2i \ 0 \ 0 \ 0 \ 0.05i \ 0.1i]$$

The following is an illustration of the impact of I/Q imbalance on the received constellation points before and after the proposed I/Q compensation scheme.

In this section, simulation results are presented for the symbol error rate obtained with different receiver schemes with and without I/Q imbalance at the transmitter and receiver. For evaluation and comparison purposes, three different receiver structures are considered.

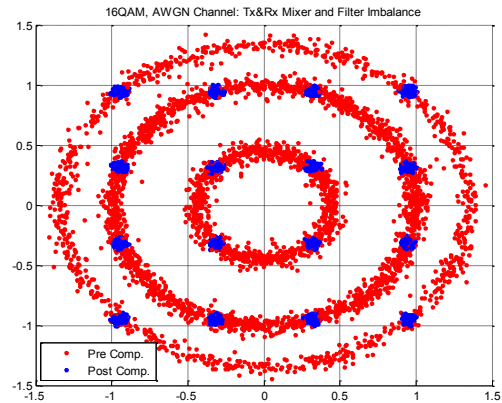
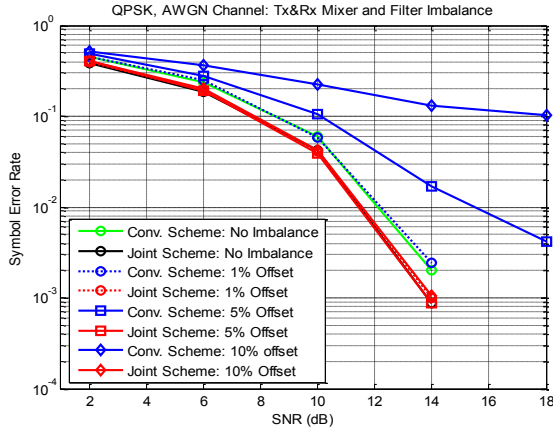
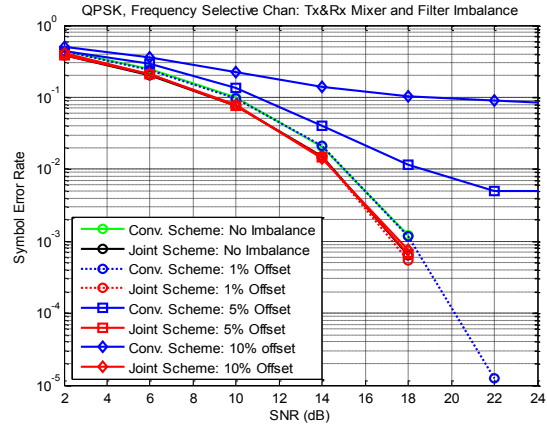

Figure 5. Mixer and Filter Imbalance output at Tx & Rx – 16QAM



a) AWGN Channel,



b) Frequency Selective Channel

Figure 6. Scenario 1, QPSK: Tx & Rx Mixer and Filter Imbalance

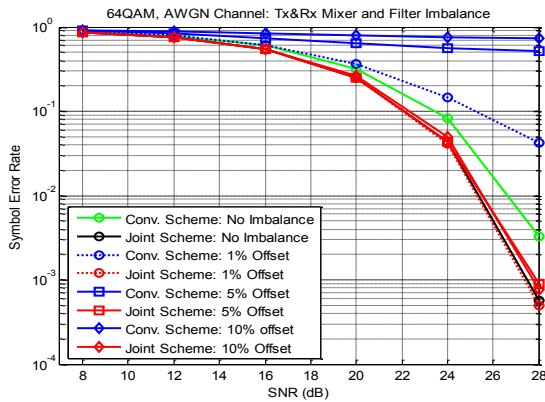

a) AWGN Channel,

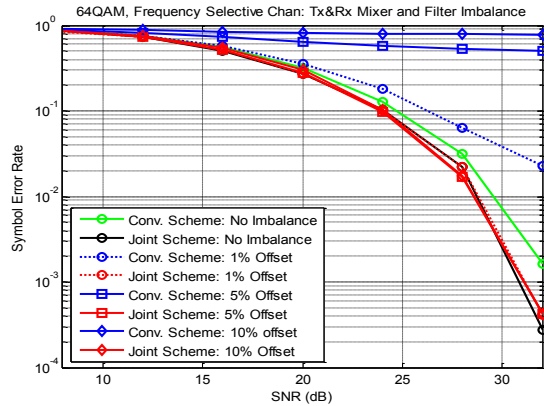

b) Frequency Selective Channel

Figure 7. Scenario 1, 64-QAM: Tx & Rx Mixer and Filter Imbalance

**Receiver Scheme 1:** Under the conventional assumption of 1 preamble transmission, the channel estimate is obtained for each tone by dividing the received signal by the pilot symbol. **Receiver Scheme 2:** uses two back-to-back preambles at the transmitter. At the receiver, joint channel estimation and I/Q imbalance compensation is used to mitigate the impact of mixer I/Q imbalance caused by Tx and Rx side impairments, as well as the filter I/Q imbalances at transmitter and receiver.

## 5. Conclusions

In this paper, we addressed the problem of I/Q imbalance, an impairment that can severely affect the reliability of communication systems due to mismatched responses in the I- and Q-branch processing circuitry. We consider two main categories of I/Q imbalance: (A) Mixer imbalance and (B) Filter imbalance. We provided a detailed analytical formulation of I/Q imbalance and channel propagation and present a solution comprising Joint compensation of Tx and Rx, I/Q filter and mixer imbalance along with channel equalization and phase offset correction in one shot.,

proposed a new dual preamble structure to allow for reliable estimation of I/Q imbalance coefficients, and proposed joint estimation and compensation technique is able to fully compensate for Tx and Rx mixer and filter imbalance along with channel equalization.

## 6. References

- [1] "Estimation and Compensation of IQ Imbalance in Broadband Communications", Marcus Windisch, Jörg Vogt Verlag, 2007
- [2] "I-Q Balancing Techniques for Broadband Receivers", fred harris, Sinjeet Parekh and Itzhak Gurantz, Software Defined Radio Conference-2005, Anaheim, CA 15-17 Nov 2005.
- [3] "Dirty RF: A New Paradigm", Gerhard Fettweis, Michael Löhning, Denis Petrovic, Marcus Windisch, Peter Zillmann, Ernesto Zimmermann, IEEE International Symposium on Personal, Indoor and Mobile Communications. 11-14 Sept 2005, Berlin, pp. 2347-2355.
- [4] "Blind Compensation of frequency-selective I/Q imbalances in wideband receivers: models and algorithms", Lauri Anttila, Valkama, M and Markku Renfors. IEEE Workshop on Signal Processing Advances in Wireless Communication, Taiwan, 20-23 Mar 2001, pp 42-45.
- [5] "Advanced Methods for I/Q Imbalance Compensation in Communication Receivers", Mikko Valkama, Markku Renfors and Visa Koivunen, IEEE Workshop on Signal Processing Advances in Wireless Communication, Taiwan, 20-23 Mar 2001, pp 395-398.