

Hybrid Communication Module – Motivations, Requirements, Challenges and Implementations

Johnny Mafra Jr.
 Márcio Hosami
 Fundação para Inovações Tecnológicas - FITec
 Belo Horizonte, Brazil
johnym@fitec.org.br
mhosami@fitec.org.br

Lucas Freitas
 Marcus Martinelli
 Antonio Almeida
 AES Eletropaulo
 São Paulo, Brazil
lucas.freitas@aes.com
marcus.martinelli@aes.com
antonio.almeida@AES.com

Abstract— Smart Grid (SG) is becoming a reality in Brazil in many projects covering different areas such as smart metering, demand-side management and distributed generation. It is known that the communications infrastructure is an essential part for a successful implementation of SG architecture and the choice of a communication system is very particular due to several weaknesses in communication technologies. In order to reduce such weaknesses, it was developed a reference design for a hybrid communication module based on the universally adopted IP protocol with two communication channels: Radio Frequency (RF) and Power Line Communication (PLC). It was used IEEE P1901.2 and IEEE 802.15.4g protocols in order to provide interoperability, reliability and resilience for the network.

This article aims to present the motivations, the communication module developed and the test results obtained in the validation stage in laboratory and on site. In addition, the project is exploiting regulations and restraining requirements.

Index Terms — IP networks, Meter reading, Protocols, Smart grids, Telemetry.

I. INTRODUCTION

AMI (Advanced Metering Infrastructure) is a main component of Smart Grids and it is an unparalleled tool to support the utilities to encourage consumers to use energy well. To accomplish an AMI system, a bidirectional communication between meters and the central control system is needed. History of AMI deployments shows that the coverage for any type of communication technology is around 95% [1]-[3]. The rework or repair of the remaining 5% represents a considerable operational cost. A good approach for AMI architecture is to transport the application protocol from the meter to the Head End System (HES) [4]. This way, the communication modules inside smart meters must be able to transport any of their application protocols in a transparent manner. AMI has several methods and techniques to connect from the end-point to application servers of the utility and

there are many standard communication protocols that can be used.

The communication solution for smart grid projects can be quite complex, as it must be taken into consideration the environment, traffic data, interoperability, among other characteristics. As it is known, data traffic on the network can be high and also there are several communication protocols which provide different data packets that contribute positively or negatively to this traffic within the communication infrastructure. Because of this, it is very important to have an adequate management planning and standardization of this information flow so as not to damage the communication network. Another point is that usage of proprietary protocols limits the available providers, causing commercial drawbacks.

The most adequate of them, due to its universality is the Internet Protocol. One of its huge advantages are the interoperability, as it is known by the Internet and the possibility of evolution, through the development of new applications. Ideally, the network should be of a meshed type, in which the direct access to the router is not needed. Neighbors can work as repeaters for the messages to the router. This decreases the router infrastructure needed. The IP protocol also allows the network to be scaled to millions of points, so it has the potential to cover the entire set of customers from utilities [4], [5].

Since this AMI last mile communications network is a low power and a lossy one, the IP protocol must have support for the protocols 6lowpan (IPv6 over Low power Wireless Personal Area Networks) and RPL (Routing Protocol) [6]. This way, one can take advantage of several IP protocol features, like reliability, resiliency, easy connection to existing back-office infrastructure and the use of IP management and security tools.

Therefore, in order to have a scalable AMI solution, the planning and the usage of standardized or open protocols is extremely necessary for smart grid applications.

II. COMMUNICATION MODULE

A. Technologies Available

There are several technologies available in the market to provide this last mile communication to meters that are a part of commercial AMI systems. We can list some technologies, such as: point-multipoint RF system with a proprietary non-transparent protocol; RF with mesh topology having one layer of the OSI model with a proprietary protocol; RF and PLC with proprietary non-transparent protocol and without the network management protocol and RF with a mesh topology without a standardized management and non-transparent protocol. In other words, none of these evaluated systems complies with all the requirements of interoperability, not to mention about the IP protocol advantages already discussed, which are not always adopted in these products.

B. Requirements

The communication module requirements are very challenging. It must be a module capable to communicate using the IP protocol in a mesh topology, so its processing capabilities must be considerable. Besides that, it must have low costs, low power consumption, compatibility with the metering equipment available at the market and the module must be small enough to fit inside the main smart meters available in Brazil. Another important issue is the certification in accordance to Brazilian regulations.

In this module, an Over The Air (OTA) firmware update feature is also mandatory. This is important for the implementation of new features and bug fixing.

C. Proposed Solutions

The solution proposed based on the requirements was to use cooperative hybrid communication technologies. So the developed communication module has PLC and RF transceivers as physical layers. Again, it is restrained by cost and power limitations, due to the presence of two transceivers, but the advantage is that where one technology presents limitations, such as walls for RF, the other performs well and vice versa, as in the case of network noise caused by electric equipment for PLC [7].

This way, there is no need of extra antennas, cables or repeaters, normally used for RF technology at the installation. And for PLC there is no need of extra filters or repeaters. Besides that, transformers are no more an obstacle for PLC. A network can be formed using RF as a bridge between PLC networks at different transformers, as shown in Figure 1. The cost reduction is not limited to equipment and accessories. The truck with tools and a specialized crew that would do the communication failure analysis and its fixing is also saved, as well as the personnel and operation desks at the operation center.

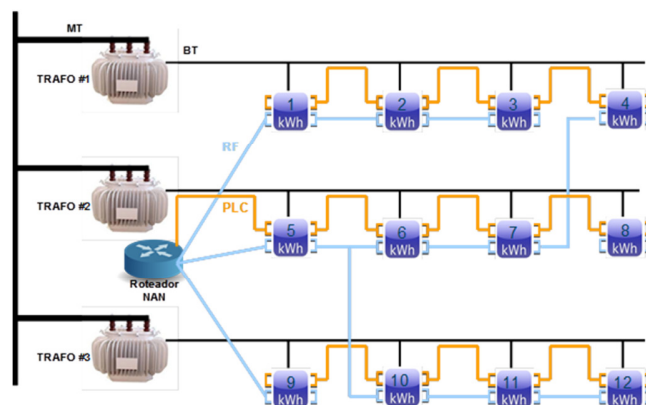

Figure 1. PLC crossing transformers through RF bridges.

For this purpose, the module has the following characteristics:

- It is divided into two PCBs (Printed Circuit Boards) for the following purposes:
 - Separate circuits that make the PLC interface from that comprising RF interface and the processor;
 - Dimensional compatibility with its assembly within the meter;
- It provides two thicknesses of PCBs, one compatible with the stackup of the RF circuit and one more suitable to larger components and weight present in the PLC coupling circuit;
- It receives only one supply (15 V DC) from the meter and internally generates voltages required for its operation;
- It provides external circuit connector for energy storage for last gasp functionality. This is more convenient because it depends on each particular solution for the meter power supply;
- It provides processing and memory capacity commensurate with the communications protocols for both the PLC and RF interfaces.

Thus, the block diagram of the communication module is as shown in Figure 2. It comprises of the RF board and the PLC board. It has as functional blocks a serial communication with the electricity meter, a connection to the power supply, a connection to the energy storage device for a feature last gasp, DC/DC converters, a processing unit, RAM, Flash memory, a PLC interface and an RF interface. The PLC interface has a zero-crossing detector as specified by IEEE P1901.2.

RF and PLC interfaces are configured to comply with the rules of the National Telecommunications Agency (ANATEL) as the band of transmission allowed [9]. Thus, RF operates with 64 channels in the frequency from 902 to 907.5 MHz and 915-928 MHz with 2-FSK modulation and the PLC with 36 channels at the range of 35-89 kHz with OFDM modulation. It should be noted that some channels are lost when frequencies

not authorized by ANATEL are filtered. The RF power is limited to 30 dBm. PLC is able to deliver a current of 1.5 A to the communication line. The duty cycle of both RF and PLC is adjusted so that the average power consumption is sufficiently smaller than the burden limit allowed by National Institute of Metrology, Standardization and Industrial Quality (INMETRO) for energy meters, which is 5 W, to allow enough power to also power the meter.

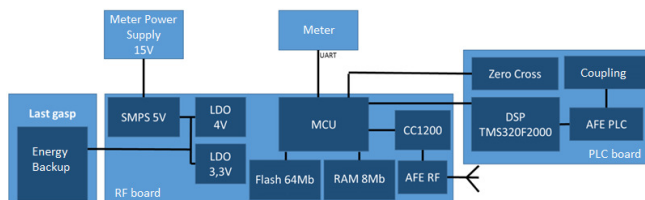

Figure 2 - Diagram of the communication module blocks.

In order to handle two different physical layers, there was a need for compatible link layers, with compatibility to the IP protocol. To achieve this for RF, it was adopted the IEC 802.15.4 standard and for PLC the IEEE P1901.2 standard. Because of these link layers, the 6lowpan adaptation layer is needed. It basically functions as a compressor to the IPv6 data packet header to fit well in the packet size at the lower layers [8]. The low power and lossy network requires UDP as a transport protocol, since its resources are not sufficient for TCP. The CoAP application layer is used to make the connections between communication modules and the Head End System, which hosts the Network Management Protocol. And finally, the application protocol can transparently communicate through this infrastructure. The protocol stack used is shown at Figure 3.

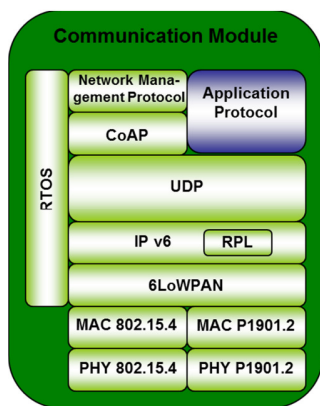

Figure 3. Protocol stack.

At the other side, the interface to the meter is an UART if the module is internal to the meter or a RS-232, if it is external.

The processor chosen was a 32-bit ARM Cortex M3, with a 1-MB internal Flash memory and a 128 KB RAM, which is a cost effective option for the needed processing power. It runs at 25 MHz, which is sufficient for the protocol stack handling.

As this processor can handle a Real Time Operational System (RTOS), as shown in Figure 3, the development is made simpler. To handle OTA feature and make the hardware future proof, external memories were added, being 8 MB of Flash and 1 MB of RAM.

To achieve the cost target, the strategy was to adopt the smallest design that can reach the biggest production automation possible. This way, the smallest devices were chosen and PTH (Pin Through Hole) devices were avoided, using the most of SMD devices possible. But even in this case, the board size wasn't small enough. To fit in the space available at the set of meters available at the Brazilian market, it was needed to use two boards in a stack. At the end, however, this solution presented some advantages. The boards were divided in RF and processor circuitry and PLC circuitry. In this way, the few big, heavy and PTH devices were placed at the PLC board, which could be thicker and more resistant. On the other hand, the RF circuitry, which demands a very specific board layer stack thickness could be made with the most appropriate thickness.

The communication module also has an Early Power Failure (EPF) input to receive the energy outage information from the meter power supply and then the firmware sends an event to the Head End System, which can feed it in an Outage Management System (OMS). This enables each Smart Meter to be a voltage sensor of the distribution network, providing high resolution outage information to the utility, so it can be better managed, contributing to energy quality indicators improvement.

The ANATEL requirements on EMC, EMI and safety were complied with using best practices in design such as well positioned decoupling capacitors, ferrite beads at supply lines, AC voltage line chokes, isolation transformer with a proper line layout, adequate layout of AC voltage input lines, use of double isolation plastic enclosure, etc. Requirements on RF and PLC bands were complied with using digital notch filters. This way, the RF band from 902 to 907,5 and 915 to 928 MHz and the PLC band from 9 to 89 kHz where easily achieved

The built communication module is shown at Figure 4.

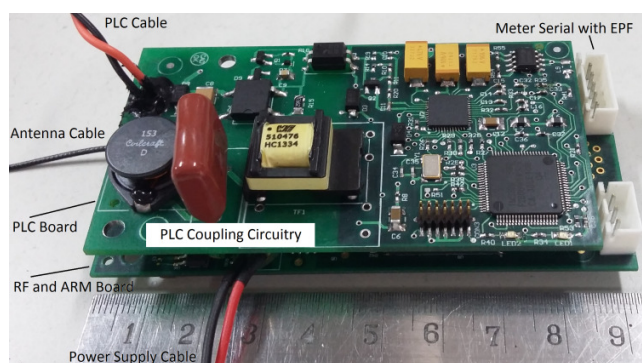

Figure 4. Board stack.

D. Lab Tests

This PLC and RF communication module based on IPv6 protocol was approved at Lab compliance and functional tests, defined at ANATEL's standards [9], [10], which are basically EMC, EMI, power interruption, electric safety, band occupation and transmission power tests. EMC, EMI and power interruption tests are those recommended at international standard series IEC 61000. The electric safety is as recommended at ITU standards. During preliminary laboratory tests, it was found that noise pulses generated during RF communication could interfere at serial ports. This was solved using best practices in EMC design, like shielding and grounding, and decoupling capacitors at the sensitive signals.

One feature that needed special attention at the test stage was the communication board burden. The RF and PLC technologies chosen drain considerable power. RF is specified for 30 dBm, which is 1,0 W. To deliver this power to the antenna, 3 to 4 W are drained from the power supply. For PLC it is even worse. The PLC amplifier drains 1,5 A at 15 V, meaning a peak power of 22,5 W. On the other hand, the average power allowed by INMETRO and IEC standards in this type of Smart Meter is 5 W in the worst case [11], [12]. The solution adopted was a compromise between transmission rate performance and power consumption in the software, reducing the transmission duty cycle of RF and PLC, leading to an average power below 2,5 W, leaving room for the smart meter self-consumption. An additional feature implemented in the firmware is that RF and PLC doesn't transmit at the same time. The measurements made for this validation are shown in Figure 5. As it can be seen, RF transmission should be limited to 4 packets per second and PLC should be limited to 1 packet at each 4 seconds to keep the average power below 2,5 W. This difference occurs because the duration of the packets are quite different, being around 90 ms with MTU (Maximum Transfer Unit) for RF and 1500 ms for PLC.

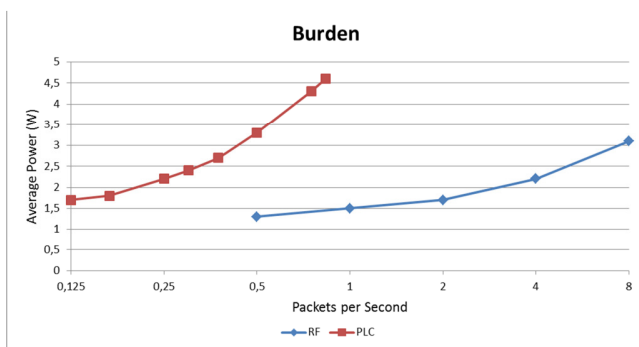

Figure 5. Average burden for RF and PLC.

E. Pilot Field Tests

A pilot field test was performed at Barueri, São Paulo, Brazil, the city chosen by AES Eletropaulo to be its Smart Grid test bed. The results were encouraging, mainly for PLC communication, which has a controlled transmission line at the low voltage distribution system outside the consumer

premises. A mesh network was formed cooperatively with RF and PLC links, as can be seen at Figure 6, which presents IPv6 addresses of the modules, being the router the first one, and the tab means the rank of each module in the mesh network. Several hops can be seen and one node works as a bridge between RF and PLC networks. This feature allows PLC to pass through power transformers, not being restricted to a transformer secondary. Most important is that all installed nodes in the field were reached by communication without any interference from the installers. This way, the observed module communication performance was adequate for low voltage consumers' smart meter reading.

```
[2001:DB8:3:E::]
\RF- 2001:DB8:3:E:1:3B02:1D:2E
\RF- 2001:DB8:3:E:1:3B03:21:38
\RF- 2001:DB8:3:E:1:3B03:31:30
\RF- 2001:DB8:3:E:1:3B03:41:24
\RF- 2001:DB8:3:E:1:3B0B:29:39
\RF- 2001:DB8:3:E:1:3B19:46:31 ←RF-PLC Bridge
\PLC 2001:DB8:3:E:1:3B02:19:36
\PLC 2001:DB8:3:E:1:3B02:1E:37
\PLC 2001:DB8:3:E:1:3B02:24:25
```

Figure 6. RF and PLC mesh network formed at pilot field test.

Field tests also included a 30 day long reliability test. To perform this test, the firmware recorded all the resets and its origin: hardware, software or exceptions. A hardware reset means a power on reset at a power restoration. A software reset could be caused by the finishing of a firmware update or by a remote reset command. Exceptions resets can be caused by watchdog, stack overflow and EPF. So, the real issues are related to reset by exceptions, more specifically watchdog and stack overflow. During the reliability test, it was only observed power on resets and EPFs, related to power outage. So, one can conclude that the hardware and firmware didn't present design failures.

Although the main objective is to search for design failures, the reliability tests can derive some failure rate results. Since this test was done with 20 pieces and zero failure was found during 30 days, this leads to a failure rate smaller than 70.000 FITs and a MTBF bigger than 1,6 years. The failure rate figure is quite big comparing to the theoretical calculated value, which is roughly ten times smaller. This is because the test time was short, as well as the number of samples. For a more accurate result, the samples should be left at the field and the failure rate should be checked again later. This will give an indication of the adequacy of the technology adopted but not from the production process, which was a manual prototype production process.

Tests were done to stress the limits of the technology performance. To achieve this, the time between network management messages and application protocol messages was decreased, while the size of messages was increased and a considerable quantity of end nodes at the same time was addressed. Despite this scenario, tests showed performance figures where the transmission rates were from 0,5 to 8 kbps for PLC and from 2 to 16 kbps for RF, the average latencies were of 3.000 ms for PLC and of 350 ms for RF and the

recommended data payload was of 64 bytes, in order to prevent network traffic jam.

III. CONCLUSIONS

All requirements were gracefully fulfilled and the communication module is now available for any meter manufacturer qualified by AES Eletropaulo to integrate it inside their products through a reference design. This will provide a high degree of interoperability, since one standardized communication module could be used at several meter models of several different manufacturers. Besides that, the module is working as well as a bridge between RF and PLC to solve the transformer boundary issue.

The tests showed that behavior related to EMC, EMI, power interruption, electric safety, band occupation, transmission power and reliability was satisfactory.

The next steps involve the manufacturing of this communication module, in a beta test lot, and its integration into some commercial energy meters. This lot will be installed at AES Eletropaulo Smart Grid project that embraces all the city of Barueri, SP, Brazil.

ACKNOWLEDGMENT

We'd like to thanks M. M. Santos, C. C. D. Barbosa, R. R. Oliveira, A. C. Arantes, C. Luiz and F. D. Gonçalves for sample building and tests conducting.

REFERENCES

- [1] L. C. P. Pereira, R. B. Romano, L. S. César, F. L. Figueiredo. "Desenvolvimento de Solução Híbrida de Rede sem Fio para Aplicação de Telemetria - "Smart Grid"," in *Cadernos CPQD Tecnologia*, 2014.
- [2] M. P. de Souza, R. F. de Souza. "TMFE - Sistema de Telemetria Fiscal Exteriorizada para redução de perdas comerciais," unpublished, presented at AES Eletropaulo Internal Workshop of AMR and AMI projects, São Paulo, Brazil, 2013.
- [3] R. B. Romano, L. S. César, P. E. S. Faria. "Desenvolvimento da Rede de Distribuição Inteligente ("Smart Grid") utilizando Soluções de Comunicação, Dispositivos Avançados e Integração de Sistemas," unpublished, presented at AES Eletropaulo Internal Workshop of AMR and AMI projects, São Paulo, Brazil, 2013.
- [4] P. Grossetete, et al. (2014, Jan.). A standardized and flexible IPv6 architecture for field area networks. Cisco, San Jose, CA.[Online]. Available: http://www.cisco.com/web/strategy/docs/energy/ip_arch_sg_wp.pdf
- [5] L. H. de Melo Leite, L. de Errico, W. do Couto Boaventura. "Criteria for the selection of communication infrastructure applied to power distribution automation," in *Proc. 2013 IEEE PES Conference On Innovative Smart Grid Technologies Latin America (ISGT LA)*.Z.
- [6] Shelby and C. Bormann. 6LoWPAN: The Wireless Embedded Internet, Wiley, 2009.
- [7] N. V. Vellano, K. T. Soletto, P. R. Pimentel, L. S. Cesar, A. S. Baldissin, G. R. Silva, C. A. Z. Cludi, C. F. Barbosa, R. B. Romano, A. A. Ribeiro, F. M. M. Araújo, A. Bagarolli. "PLC Systems Performance Analysis Regarding Power Quality Disturbances," in *Proc. 2007 ISPLC '07. IEEE International Symposium*, pp. 390-395.
- [8] S. A. Catapang, Z. J. M. Roberts, K. I-Kai Wang, Z. Salcic "An Infrastructure for Integrating Heterogeneous Embedded 6LoWPAN Networks for Internet of Things Applications," in *Proc. 2013 Seventh International Conference on Sensing Technology*, pp. 741-746.
- [9] *Regulamento sobre Equipamentos de Radiocomunicação de Radiação Restrita*. ANATEL RES 506, Jul. 2008.
- [10] *Regulamento para certificação de equipamentos de telecomunicações quanto aos aspectos de compatibilidade eletromagnética*. ANATEL RES 442, Jul. 2006.
- [11] *RTM para medidores eletrônicos de energia elétrica ativa e/ou reativa, monofásicos e polifásicos*, INMETRO RTM 587, Nov. 2012.
- [12] *IEC Electricity metering equipment (a.c.) – Particular requirements – Part 61: Power consumption and voltage requirements*. IEC 602053-61:1998.