

Design of Combined PWM/PFM Controlled Boost Converter for Pulsed Doppler Ultrasound Transmitters

Kun Chu Lee and Chin Hsia, *Member, IEEE*
National Central University
chinhsiancu2014@gmail.com

Abstract—The paper presents a boost converter design for medical ultrasound transmitters, particularly applying to a pulsed Doppler ultrasound system. A dual mode controller is employed for the boost converter to maintain high efficiency over a wide load range. The device operates from a 3.3-V supply, capable of producing a 10V output DC voltage. Simulated results exhibit the capability of the designed boost converter can supply 500 mA maximum current with the peak efficiency over 92%, and achieves more than 75% efficiency with a light load of above 10 mA.

I. INTRODUCTION

Ultrasonic imaging is one of the popular non-radiative modalities for medical diagnosis [1-2]. CW Doppler ultrasound, which contains Doppler-shifted frequencies, is another important technique to measure and detect blood flow within the human body for further analysis. Pulsed Doppler ultrasound is similar to CW Doppler except the transmitting signal is pulsed. This facilitates the technique to measure range as well as blood flow. Fig. 1 shows a block diagram of typical pulsed Doppler ultrasound system, which consists of a transmitter, a pulse modulator, a high-voltage operational transconductance amplifier (HV OTA), a mixer, a high-Q filter, a low noise amplifier (LNA), and a range and spectrum analyzer. The HV OTA, functioned as a high-voltage pulser, produces pulsed, high voltage linearly amplitude modulated signals to excite the ultrasound probe. Then the receiving signal is synchronously detected by mixing a reference signal coupled from the transmitter to the echo signals. Since HV OTA operates primarily with a light load (≤ 10 mA) condition and only produces pulses intermittently for this type of application. Its power supply, usually a boost converter, therefore, provides with full load current (≥ 500 mA) in a short period of time and mostly in standby mode. For the sake of a portable and compact ultrasound system, the power supply has to supply currents large enough for the OTA to excite the ultrasound probe, while energy efficient in standby mode conditions. It is critical for optimizing the overall efficiency of battery-powered boost converter in such an application with a wide range load condition.

In order to design a boost converter with low standby power but large current sourcing capability, conventional

The author would like to thank the Ministry of Science and Technology, Taiwan, R.O.C. for the project funding support under project number 106-2221-E-008 -061 -.

pulse width modulation (PWM) controller cannot meet the requirements. [3-4]. This paper proposes a simple but an effective control for the boost converter with the capability of providing a large current to the HV OTA while it is pulsing, and keeping a relatively low standby current while the OTA is off by using a combination of PWM and Pulse Frequency Modulation (PFM) [5-6] dual-mode controller.

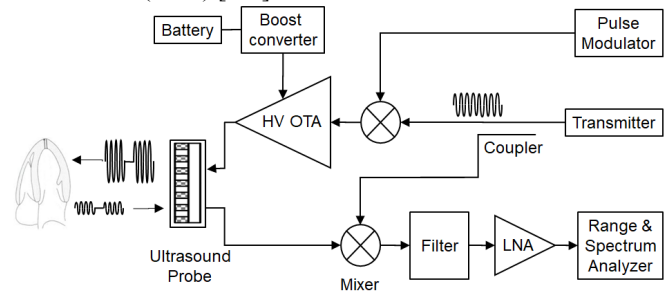

Fig. 1 A typical pulsed Doppler ultrasound system

II. BOOST CONVERTER DESIGN

The presented controller architecture of the boost converter is shown in Fig. 2, which includes PWM and PFM controllers and a mode control multiplexer. The mode control determines the mode of operation (PFM or PWM) based on the magnitude of output voltage. The output of comparator, which compares the scaled output voltage and a predetermined reference, V_{ref} , determines the mode switching point from PFM to PWM. The PWM control consists of an error amplifier, a PWM comparator, and an inductor current sensing signal. In the PFM control, the comparator detects the ripple of inductor current and controls the magnitude of the ripple by setting the hysteresis band (V_{ref_H} and V_{ref_L}) to reduce the output voltage ripple.

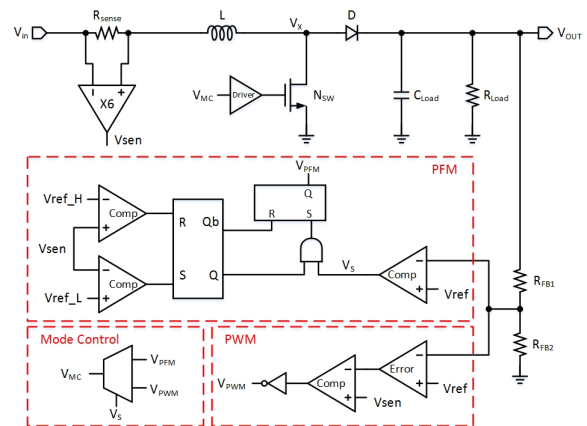

Fig. 2 Controller schematic of the boost converter

III. SIMULATION RESULTS

The load regulation waveform together with the output voltage and the inductor current are analyzed with simulations as shown in Fig. 3. The converter regulates the output to a 10 V with the input voltage of 3.3 V and the maximum current sourcing capability of 500 mA. For dual-mode operation, smooth transitions between PWM and PFM modes should be designed in accordance with load condition changes [3]. In our design, the PFM and PWM control are overlapped with each other, which leads to output ripple under $\pm 2.5\%$ of the output voltage at load transient conditions ranging from 10 mA to 500 mA.

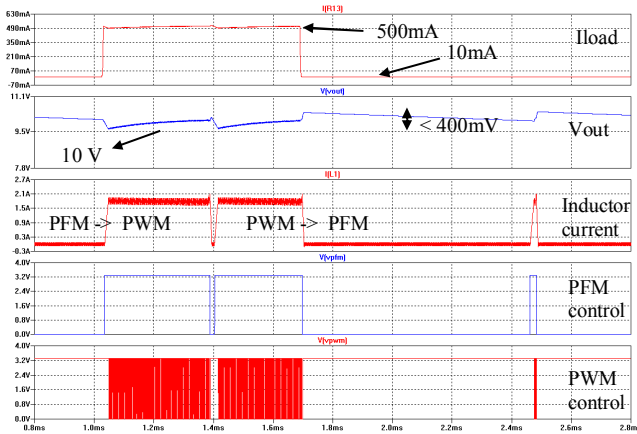

Fig. 3 The simulated boost converter waveforms

Figure 4 presents the simulated efficiency of the boost converter. The converter achieves more than 75% efficiency above 10 mA load and 92% peak efficiency as the output is loaded with 25-ohm resistance. Over 85% efficiency is maintained from 50 mA to 500 mA and over 75% efficiency is maintained from 10 mA to 50 mA, representing high efficiency over a wide output load range. Table I summarizes a performance comparison with several previous works.

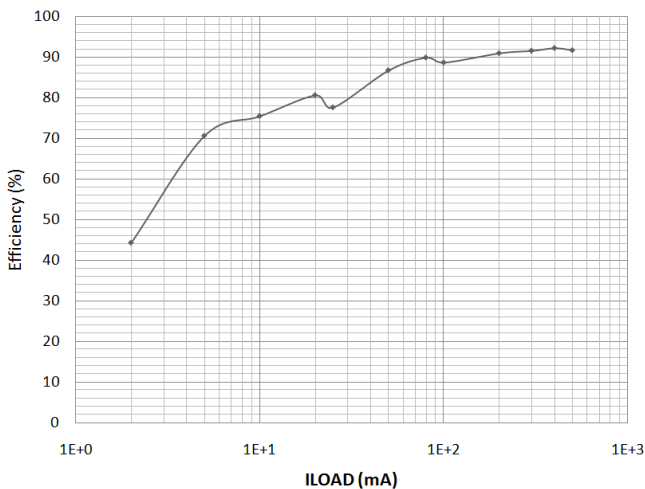

Fig. 4 Simulated efficiency of the designed boost converter

TABLE I
PERFORMANCE SUMMARY

	[3]	[4]	[5]	This work
Process	0.13 μ m	External SW	0.18 μ m	External SW
Controller	Asynchronous			
Mode	PFM/PWM	PFM/PWM	N/A	PFM/PWM
Input Voltage (V)	5.5	2.5	3.3	3.3
Output range (V)	12	5	10	10
L (DCR)	2.2 μ H	4.7 μ H	4.7 μ H	22 μ H
C (ESR)	10 μ F	4.7 μ F	100 μ F	22 μ F
Diode VF	600 mV	500 mV	N/A	450 mV
Load Range	0-600 mA	10-300 mA	10-150 mA	10-500 mA
Efficiency @ Light load	85 % @ 200 μ A	60 % @ 10 mA	65 % @ 10 mA	75 % @ 10 mA
Load (mA) for efficiency > 90%	2-150	-	-	200-500
Load (mA) for efficiency > 85%	0.2-600	-	-	50-500
Maximum efficiency	91 %	79 %	81 %	92 %

IV. SUMMARY

Design of a high efficiency boost converter applied to pulsed Doppler ultrasound is addressed in this paper. The boost converter operates with a dual mode control based on load requirements. Switch between PWM and PFM control is relatively simple to implement. At heavy load, the converter operates at PWM mode to regulate the output voltage. At light load, PFM control kicks in and the switching frequency goes down to maintain relative high system efficiency. This is beneficial for the battery-operated system. The maximum ripple based on the dual mode control is limited to 5% of the output voltage.

REFERENCE

- [1] C. Hsia, Y. Huang, and C-W. Lu, "Single-chip ultra high slew-rate pulse generator for ultrasound scanner applications", Ultrasonics Symposium (IUS), 2013 IEEE International, July, pp. 21-25.
- [2] P. Behnamfar and S. Mirabbasi, "Design of a high-voltage analog frontend circuit for integration with CMUT arrays," in Proc. IEEE BioCAS 2010, pp. 298-301.
- [3] K. Lee, H. Kim, J. Yoon, H.-S. Oh, B.-Ha Park, H. Park, Y. Lee, "A high efficiency wide-load-range asynchronous boost converter with time-based dual-mode control for SSD applications", 2016 IEEE Asian Solid-State Circuits Conference (A-SSCC), 2016, pp. 13 - 16.
- [4] Z. Shen, N. Yan, and H. Min, "A Multimode Digitally Controlled Boost Converter With PID Autotuning and Constant Frequency/Constant Off-Time Hybrid PWM Control," IEEE Trans. Power Electronics, vol. 26, no. 9, pp. 2588-2598, September 2011.
- [5] B. Serneels, E. Geukens, B. D. Muer, and T. Piessens, "A 1.5W 10V Output Class-D Amplifier Using a Boosted Supply from a Single 3.3V Input in Standard 1.8V/3.3V 0.18 μ m CMOS," IEEE ISSCC, pp. 94-96, February 2012.
- [6] C. Qiao and J. Zhang, "Control of Boost type Converter at Discontinuous Conduction Mode by Controlling the Product of Inductor Voltage-Second", 2005 IEEE 36th Power Electronics Specialists Conference, 2005, pp. 1213 - 1219.