

UTRF-90 Component and Hardware List

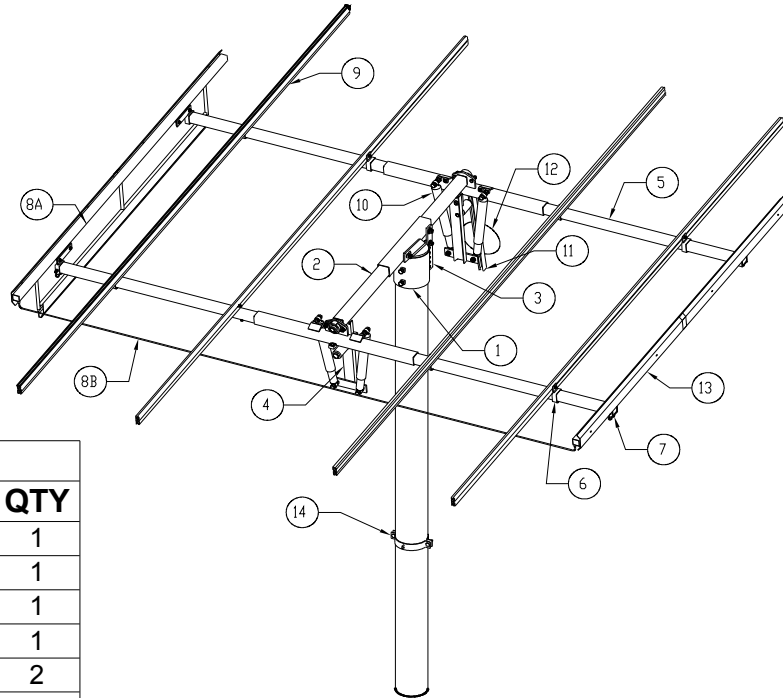

| Components | | |
|-------------------|--------------------|------------|
| Part # | Description | QTY |
| 1 | Gimbal | 1 |
| 2 | Axle Tube | 1 |
| 3 | Seasonal Adj. Bar | 1 |
| 4 | Shock Mounting Arm | 1 |
| 5 | Truss Tube | 2 |
| 6 | Rail Slider | 8-12 |
| 7 | Canister Slider | 4 |
| 8A | Canister Set | 1 |
| 8B | Transfer Tube | 1 |
| 9 | Mounting Rail | 4-6 |
| 10 | Shock Absorber | 4 |
| 11 | Counterweight Arm | 1 |
| 12 | 25lb Counterweight | 1 |
| 13 | Shadow Plates | 4 |
| 14 | Storm Collar | 1 |

For product and purchase inquiries contact:

ecoDIRECT

CLEAN ENERGY SOLUTIONS

www.ecodirect.com | 888-899-3509

| <u>Component</u> | <u>Hardware Description</u> | <u>QTY</u> | <u>Location</u> |
|------------------|-----------------------------|------------|-----------------|
|------------------|-----------------------------|------------|-----------------|

| | | | |
|---------------------------|-------------------------|---|---------------------|
| Gimbal | 3/4" x 2" Hex Bolt | 2 | Gimbal |
| | 3/4" x 4-1/2" Hex Bolt | 1 | Gimbal |
| | 3/4" Flat Washer | 2 | Gimbal |
| | 3/4" Hex Nut | 1 | Gimbal |
| | 3/4" Spring Lock Washer | 1 | Gimbal |
| | 3/8" All-Thread Rod | 1 | Hardware Bag |
| Seasonal Adj. Bar | 3/8" Hex Nut | 4 | Hardware Bag |
| | 5/8" x 4-1/2" Hex Bolt | 1 | Seasonal Bar |
| | 5/8" x 2" Hex Bolt | 1 | Seasonal Bar |
| | 5/8" Flat Washer | 4 | Seasonal Bar |
| | 5/8" Spring Lock Washer | 2 | Seasonal Bar |
| Shock Mounting Arm | 5/8" Hex Nut | 2 | Seasonal Bar |
| | 1/2" x 1-3/4" Hex Bolt | 2 | Mounting Arm |
| | 1/2" Flat Washer | 4 | Mounting Arm |
| | 1/2" Nylock Nut | 2 | Mounting Arm |

| <u>Component</u> | <u>Hardware Description</u> | <u>QTY</u> | <u>Location</u> |
|--|------------------------------------|-------------------|------------------------|
| Locking Bar | 3/4" x 3-1/2" Hex Bolt | 1 | Locking Bar |
| | 3/4" x 1-1/2" Hex Bolt | 1 | Locking Bar |
| | 1" (diameter) x 2" Spacer | 1 | Locking Bar |
| | 3/4" Hex Nut | 1 | Locking Bar |
| | 3/4" Jam Nut | 1 | Locking Bar |
| Shock Hardware | 3/4" x 2-3/4" Hex Bolt | 2 | On Shock |
| | 3/4" x 3-1/2" Hex Bolt | 2 | On Shock |
| | 3/4" Hex Nut | 2 | On Shock |
| | 3/4" Jam Nut | 4 | On Shock |
| | 3/4" Spring Lock Washer | 2 | On Shock |
| Bumper Bolt | 1" x 6" Hex Bolt | 1 | Hardware Bag |
| | 1" Jam Nut | 1 | Hardware Bag |
| | EPDM Rubber Bumper | 1 | Hardware Bag |
| | 0.5 mL Tube of Loctite | 1 | Hardware Bag |
| Storm Collar | 1/2" x 2-1/2" Round Head Bolt | 2 | Hardware Bag |
| | 1/2" Hex Nut | 2 | Hardware Bag |
| | 1/2" Spring Lock Washer | 2 | Hardware Bag |
| Rail Slider (qty. varies with rail configuration) | 3/8" x 1" Round Head Bolt | 8-12 | On Slider |
| | 3/8" x 3/4" Hex Bolt | 8-12 | On Slider |
| | 3/8" Flat Washer | 8-12 | On Slider |
| | 3/8" Nylock Nut | 8-12 | On Slider |
| | 3/8" Jam Nut | 8-12 | On Slider |
| Canister Slider | 3/8" x 1-1/4" Hex Bolt | 8 | On Slider |
| | 3/8" x 3/4" Hex Bolt | 8 | On Slider |
| | 3/8" Flat Washer | 16 | On Slider |
| | 3/8" Nylock Nut | 8 | On Slider |
| | 3/8" Jam Nut | 8 | On Slider |
| Truss Tube / Axle | Cast Iron Flange Bearings | 2 | Truss Tube |
| | 9/16" x 2" Hex Bolt | 4 | Truss Tube |
| | 9/16" Spring Lock Washer | 4 | Truss Tube |
| | 9/16" Hex Nut | 4 | Truss Tube |
| | 1" Brass Spacer | 1 | On Axle |
| | 5/32" Allen Wrench | 1 | Hardware Bag |
| | 3/16" x 7-5/8" U.V. Zip Tie | 9 | Hardware Bag |
| Counterweight Arm | 1/2" x 2" Hex Bolt | 1 | On Arm |
| | 1/2" Flat Washer | 2 | On Arm |
| | 1/2" Lock Washer | 1 | On Arm |
| | 1/2" Hex Nut | 1 | On Arm |
| | 3/4" Plastic Spacer | 1 | On Arm |
| | 1" Jam Nut | 1 | On Arm |
| Shadow Plate | 1/4" x 3/8" Round Head Screw | 8 | Hardware Bag |
| | 1/4" Fender Washer | 8 | Hardware Bag |
| | 1/4" Spring Lock Washer | 8 | Hardware Bag |
| Module Hardware (per module) | 1/4" x 5/8" (Stainless) Hex Bolt | 4 | Hardware Bag |
| | 1/4" (Stainless) Flat Washer | 4 | Hardware Bag |
| | 1/4" (Stainless) Flange Nut | 4 | Hardware Bag |
| Offset Bracket Kit (only w/ extra rails) | 3/8" x 1-1/4" Hex Bolt | 4 | On Bracket |
| | 3/8" Flat Washer | 8 | On Bracket |
| | 3/8" Nylock Nut | 4 | On Bracket |