

Xantrex™ PRO 1000 & 1800 Inverters

xantrex™



XM 1000 and XM 1800
modified sine wave inverters
with transfer switch

Performance inverters designed for RVs and boats

Designed for RV and marine electrical systems that already have a battery charger or generator installed, Xantrex PRO Inverters deliver modified sine wave power for small appliances, TVs, and other onboard electronics from a battery bank. The XM 1000 and 1800 models are the perfect complement to generators when shore power is unavailable, to quietly and efficiently provide household power when needed.

The Xantrex PRO Series design is both user friendly and versatile. These inverters feature a detachable, digital remote control to display precise inverter, AC source and battery status information from one convenient location. A built-in transfer switch automatically detects when generator or shore power status changes to ensure power is always available.

Both XM 1000 and 1800 models are designed for demanding RV and marine conditions. They meet FCC Class B regulations to eliminate interference potential with other electronics, while UL 458 certification means they meet strict RV and marine safety standards. Versatile enough to be mounted either horizontally or vertically, these inverters can be easily installed to fit into any compartment. Conformal coated boards also minimize the chance of problems from moist operating conditions.

Performance Features

- ▶ 1000/1800W inverter easily powers TVs, small appliances, and other electronics
- ▶ Built-in 15A circuit breaker on AC pass-through
- ▶ Up to 15A/20A pass through for hardwired loads for XM1000/XM1800 respectively
- ▶ Digital remote control displays power output, AC source and battery voltage
- ▶ Detachable remote control can be mounted wherever convenient
- ▶ Conformal coated electronics provide moisture resistance
- ▶ Designed to be hard-wired using a terminal strip or by connecting AC through a GFCI receptacle (included)

Protection Features

- ▶ Battery over-voltage and under-voltage protection
- ▶ Over temperature shutdown
- ▶ Automatic overload protection
- ▶ Short-circuit protection
- ▶ Ground fault protection



ETL approved to UL 458

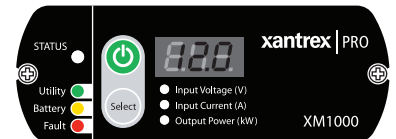

Xantrex Technology Inc.

Headquarters
8999 Nelson Way
Burnaby, British Columbia
Canada V5A 4B5
800 670 0707 Toll Free
604 420 1591 Fax

541 Roske Drive, Suite A
Elkhart, Indiana
USA 46516
800 446 6180 Toll Free
574 294 5989 Fax

www.xantrex.com

Xantrex PRO 1000 & 1800 Inverters

Electrical Specifications		
Models	XM1000	XM1800
Maximum continuous power	1000 W	1800 W
Surge rating	2000 W	3600 W
Output current (continuous)	8.3 A	15 A
Output voltage (at no load)	115 V +/- 10 V	115 V +/- 10 V
Output frequency	60 Hz +/- 1 Hz	60 Hz +/- 1Hz
Output waveform	Modified sine wave	Modified sine wave
Peak efficiency	88%	88%
No load power draw	< 6 W	< 6 W
Power draw in standby mode	< 2 W	< 2 W
Input operating voltage range	11.0-15.5 VDC	11.0-15.5 VDC
Transfer relay rating	15 A	20 A
Transfer time	40 milliseconds	40 milliseconds

General Specifications		
Operating temperature range	0°C - 40°C	0°C - 40°C
Storage temperature range	-20°C - 60°C	-20°C - 60°C
AC receptacles	2	2
Recommended DC fuse	150 A	250 A
Dimensions (H x W x D)	103 x 211 x 329mm	103 x 211 x 393mm
Weight (lbs)	7.5	9.5
Warranty	1 year	1 year
Part numbers	806-1010	806-1810

Regulatory Approvals For product and purchasing inquiries contact:
 FCC Class 'B', UL 458



Note: Specifications subject to change without notice.

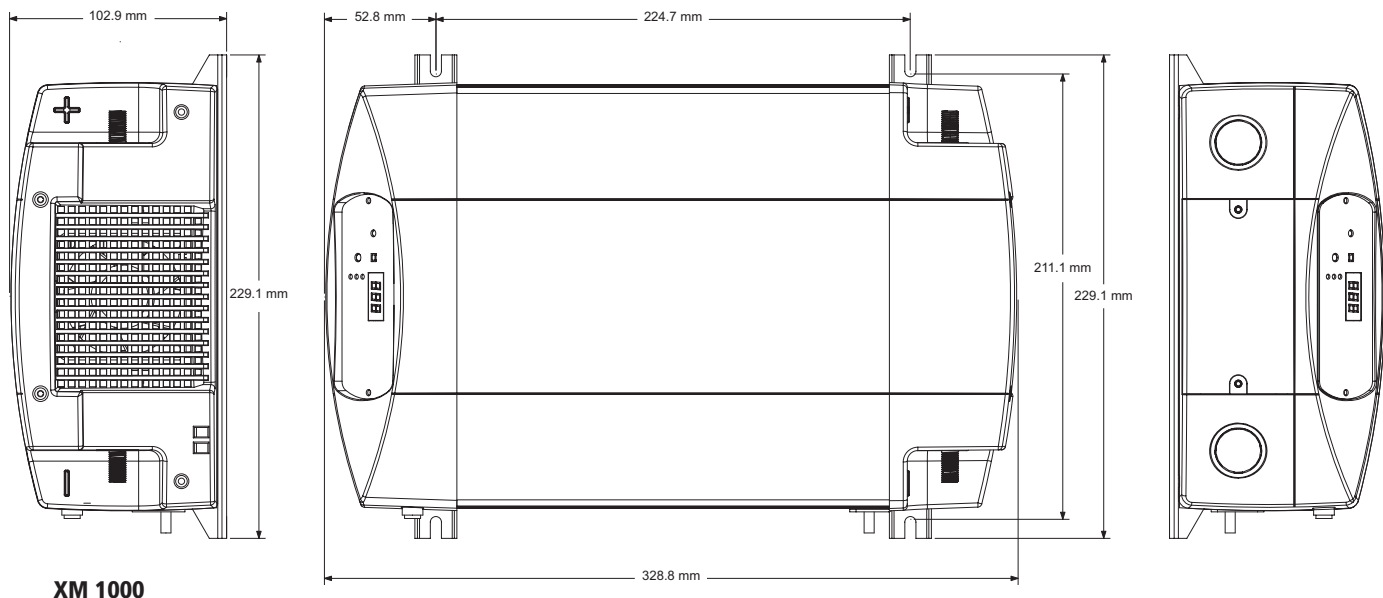

XM 1000