

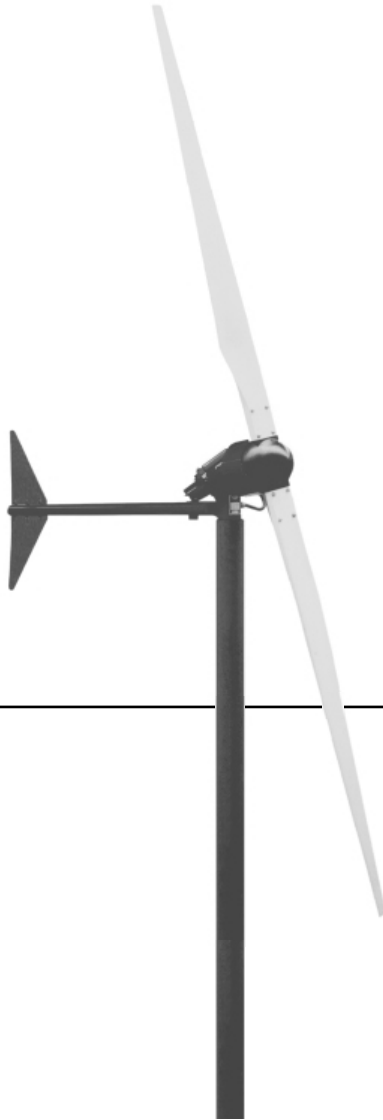

Whisper 500

OWNER'S MANUAL

Installation
Operation
Maintenance



CE

TABLE OF CONTENTS

SWWP Welcome Letter	3
Safety & Tips.....	4
Whisper 500 Technical Specifications.....	5
Whisper 500 Battery Charging Schematic.....	6

PRIOR TO INSTALLATION

Siting Tips.....	7
Tower Selection.....	8
Arrival Kit.....	9
Battery Sizing Tips.....	10
Battery Configuration and Location	11
Wind Turbine Electrical Tests.....	12
System Wiring.....	13

INSTALLATION

*For field installation it may be useful to print this section.....	14
Setting Wind Turbine Voltage	15-16
Turbine Assembly	17-20
Mounting Wind Turbine On Tower.....	21-24
Brake Switch Installation	25
Whisper Controller – Mounting.....	26
Whisper Controller – Diversion Load Wiring	27
Transformer Wiring	27
Whisper Controller - Circuit Board Switches and Reset Button.....	28-29
Optional Display Installation.....	31

OPERATION AND ADJUSTMENTS

Operation of the Whisper Controller	30
1. Whisper Controller Overview.....	30
2. Normal Operation – Whisper Controller	30
3. Diversion Switch	30
4. LED Operation	30
5. Setting Regulation Voltage (without Display).....	31
6. Whisper Controller Display.....	31
Display Menu Ring Structure.....	31
Display Menu Functions.....	32

MAINTENANCE AND REPAIR

Maintenance – Monthly	33
Maintenance - Annual.....	33
Maintenance Log.....	34
Troubleshooting - Table: Symptoms of Mechanical Problems	35
Troubleshooting - Electrical Diagnosis.....	36
Troubleshooting - Voltmeter Test.....	37
Troubleshooting - Table:Symptoms of Controller Problems.....	37
Troubleshooting - Table: Symptoms of Electrical Problems.....	38

Whisper Wind Turbine Warranty Agreement.....	39
---	-----------

Whisper 500 Owners Manual
3-CMLT-1025 Revision D

Southwest Windpower

Congratulations on your purchase and welcome to our family!

Dear Whisper™ Owner,

Thank you for your purchase of a Whisper wind turbine. We congratulate you on your choice and are confident you will experience years of dependable service.

Before going any further, please complete and return the enclosed Warranty Registration Card. **The conditions of your warranty are dependent upon the proper installation of Whisper.** Furthermore, this will assure you of being kept up-to-date with the latest developments from Southwest Windpower. These include new options, performance tips, updated software to maximize output and user notices. It is important to know that we do not sell or distribute your information to any third party. We understand your privacy is important.

Again, welcome to our family and thank you for investing in the future of wind energy with Whisper.

Sincerely,

Southwest Windpower

CE Compliance: The CE marking is a mandatory compliance requirement in EMEA and the UK and although it is self-certification, testing and evidence support testing is preferred from an independent test house. All Southwest Windpower turbine are third party tested and fulfill all the relevant provisions of the following directives: Machinery Directive 2006/42/EC, Low Voltage Directive 2004/95/EC, Electromagnetic Compatibility Directive 2004/108/EC. The report and declaration of conformity are available for inspection on request. The serial number refers to a specific Southwest Windpower product. This product is considered compliant to CE.

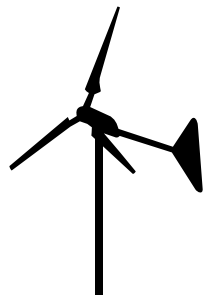

Enter the serial and model number below

Serial Number _____

Model Number _____



Southwest Windpower Inc.
1801 W. Route 66
Flagstaff, AZ 86001 USA
customerservice@windenergy.com
(928) 779-9463

Southwest Windpower GmbH
Mannesmannstr. 6
50996 Cologne
Germany
Tel: +49 (0) 221 16 53 94 50
www.southwestwindpower.eu

Designed in the USA by Southwest Windpower. Manufactured under license by Luminous Renewable Energy Solutions, India.





IMPORTANT SAFETY INSTRUCTIONS

Read these instructions in their entirety before installing or operating.

-  **SAVE THESE INSTRUCTIONS.** Enclosed are important instructions that must be followed during installation and maintenance.
-  Turn Whisper “OFF” and contact Southwest Windpower Technical Service if unusual noise or operation is observed.
-  Install Whisper on a calm day - no wind at ground level.





In this manual

-  **IMPORTANT:** Please take note
-  **TIP:** Helpful information
-  **WARNING:** Risk of injury or death - proceed with extreme caution
-  **MARINE:** Information specific to corrosive environments

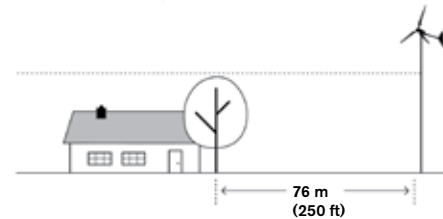
-  **Locate your tower well away from occupied buildings and power lines; a minimum of 76 m (250 ft) is recommended.**



-  **High voltage systems present a shock hazard and should be wired and maintained by a qualified and licensed electrician.**
-  **NEVER** place objects on top or near the Whisper Controller enclosure.



These devices must dissipate heat as part of normal operation. **FAILURE AND FIRE** may result if airflow is blocked.

Recommended Tools, Equipment and Materials for Installation

Rounded File	Electrical Tape
Ground Rod & Clamp	Electrical Wire and Voltmeter
Wrenches (2) 13mm & 17mm or Adjustable Wrenches	Torque Wrench (20N-m or 15ft-lb) and 13mm & 17mm Deep Socket
Electric Drill Motor & 12mm (1/2") Metal Cutting Drill Bit	Soldering Iron and Solder or Split Bolt Connectors
Leather or Strong Fabric Strap (secures casting while handling)	Cable Grip/Strain Relief (support wires inside tower)
Metric Hex Wrench Set	Loctite 242
Center Punch Tool (marks for drilling)	Sawhorses
Pliers	Small Flashlight

Whisper 500 Technical Specifications

WHISPER 500

Rated Power	3000 watts at 10.5 m/s (24 mph)
Monthly Energy	538 kWh/mo at 5.4 m/s (12 mph)
Start-Up Wind Speed	3.4 m/s (7.5 mph)
Rotor Diameter	4.5 m (15 ft)
Voltage	24, 48 VDC* (HV 230V available)
Overspeed Protection	Patented side-furling
Turbine Controller	Whisper controller (Optional)
Mount	12.7 cm pipe (5 in Schedule 40)
Body	Welded steel with corrosion resistant finish
Blades	(2) Carbon reinforced fiberglass
Survival Wind Speed	55 m/s (120 mph)
Weight	70 kg (155 lb)
Shipping Dimensions	Body: 914 x 635 x 812 mm (36 x 25 x 32") Blades: 2235 x 305 x 152 (88 x 12 x 6")
Warranty	5 year limited warranty

*Power ratings are normalized for sea level.

*** The Whisper LV (low volt) Controller is factory set at 48-volt operation and the Whisper HV (high volt) controller is factory set at 230-volt operation. All system components, Wind Generator, Whisper Controller, diversion load, transformer and inverter (if applicable) must be configured to the correct system voltage.**

 **Note the weight above. Use safe lifting techniques and protective footwear.**



Turbine casting pivots open to a 45 ° angle creating a potential pinch point.



Southwest Windpower strongly recommends:
Strapping or securing the casting (as shown below) while handling so it cannot pivot open.

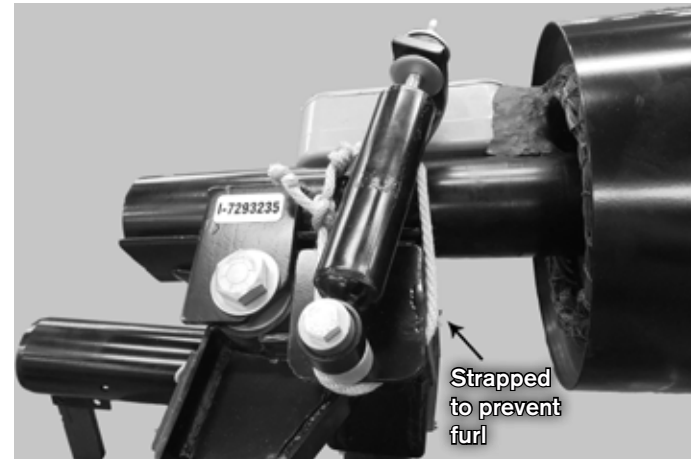

Do not remove strap until casting is secure on tower.

Whisper 500 Battery Charging Schematic

You will need to make the electrical connections as shown below.

**Whisper 500
Wind Generator**

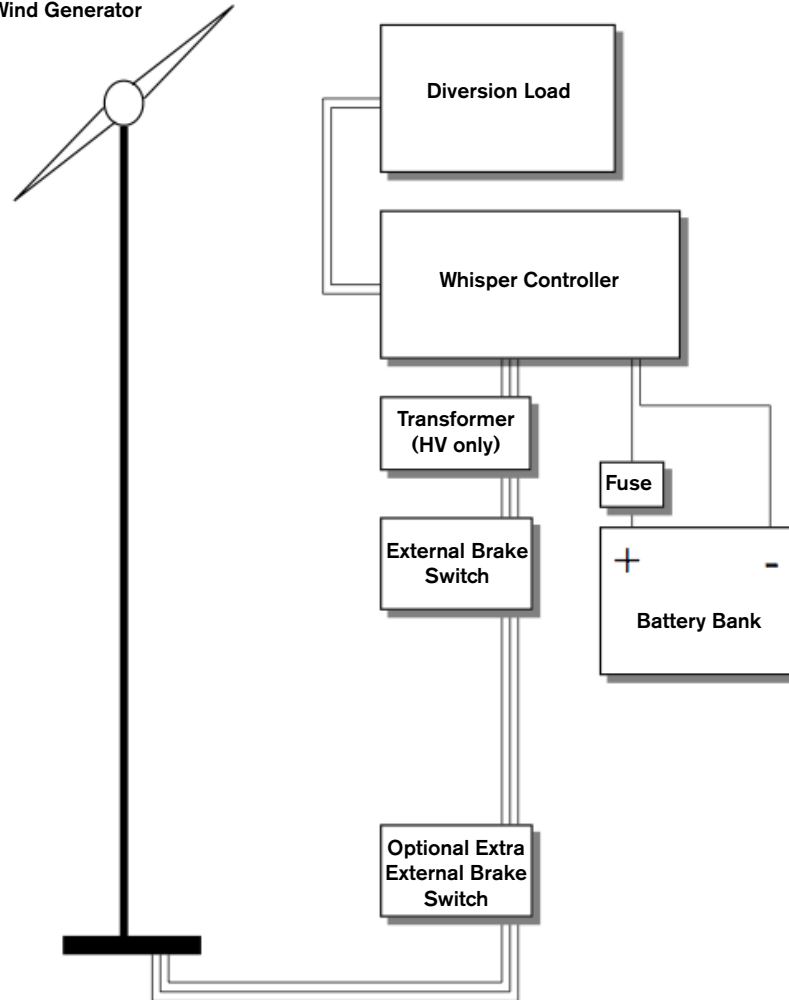

Note: Size the three phase wire between the turbine and Whisper Controller using the "System Wiring Table"

PRIOR TO INSTALLATION

Siting Tips

- PROPER SITING = Better Performance & Increased Longevity**
Look at vegetation deformation to determine best area and prevailing wind direction.

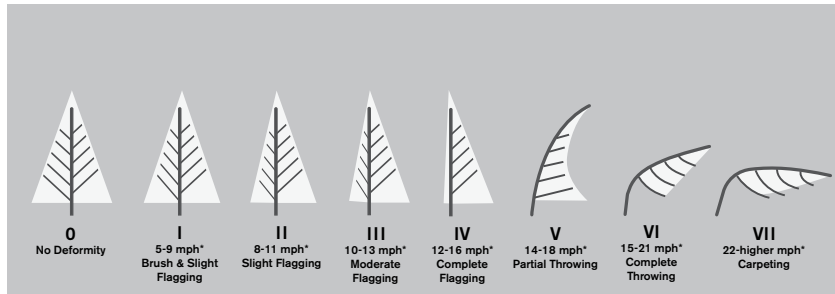

Griggs-Putnam Index. *Probable mean annual windspeed. Data prepared by E.W. Hewson, J.E. Wade, and R.W. Baker of Oregon State University

- EXCESSIVE TURBULENCE = Fatigue Damage & Shorter Turbine Life**

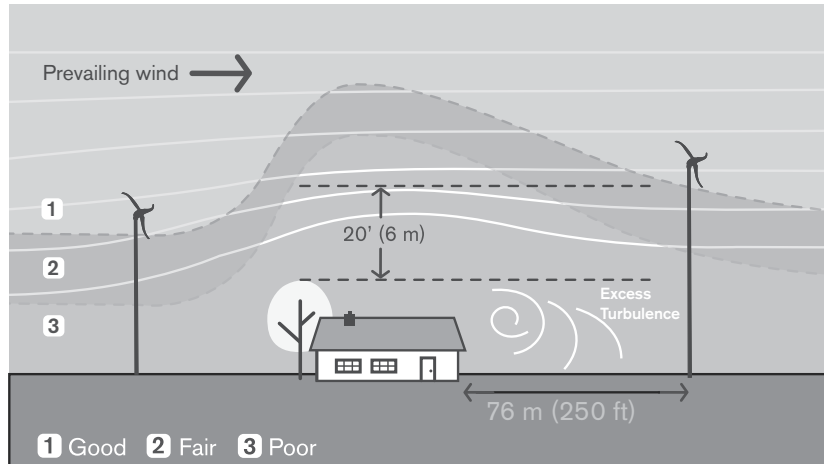

Turbine should be a minimum of 76m (250 ft) away from and 6m (20 ft) above obstacles.

- ATYPICAL SITING CONSIDERATIONS**

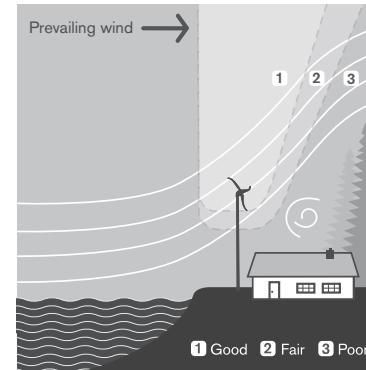

Coastal or Lakeside

Trees and taller structures can be down-wind.

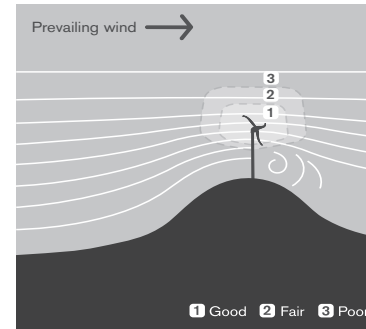

Ridge Tops

Wind compresses as it blows over the top of a hill, increasing the wind speed.

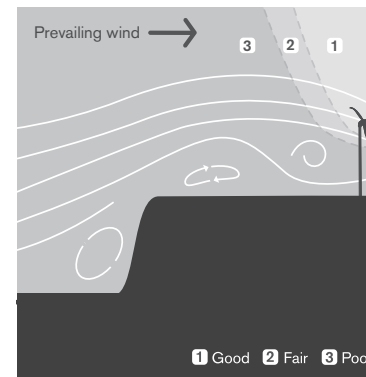

Plateau/Mesa

Site the generator far enough from the cliff to avoid turbulent wind.

ARRIVAL KIT Turbine Package

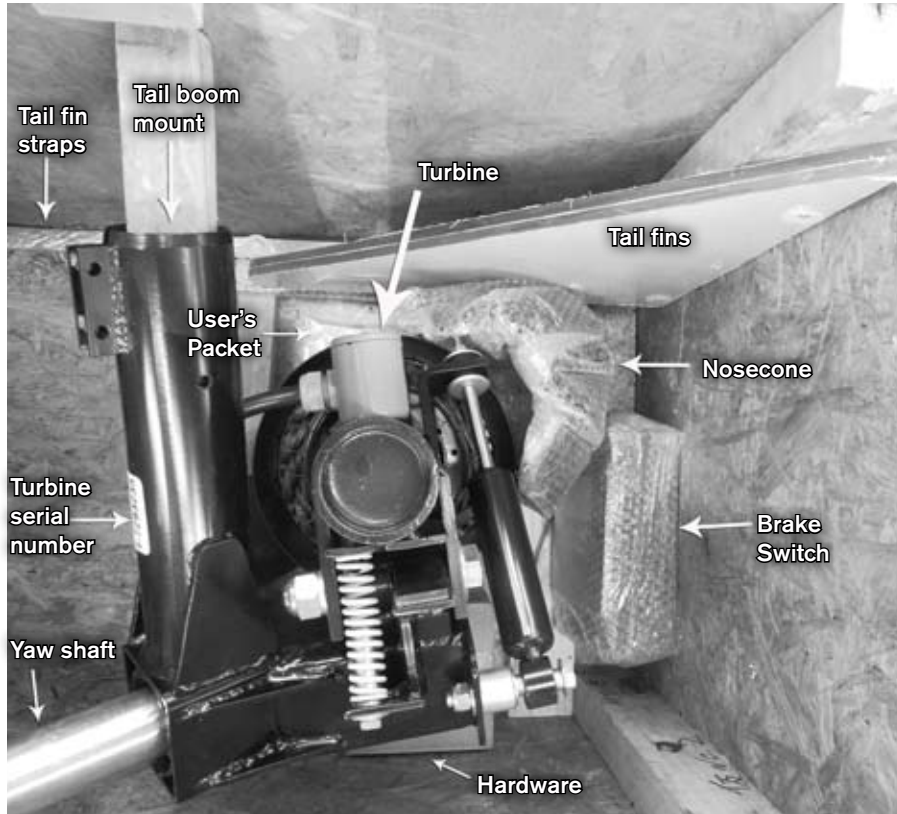

Blade Package

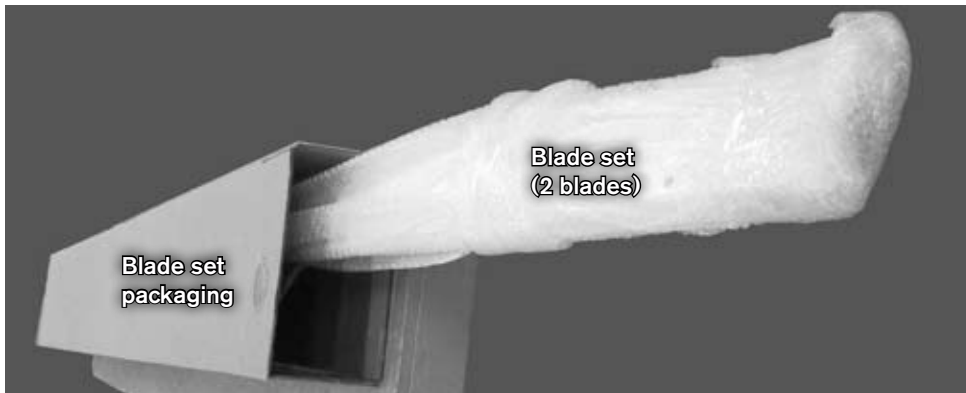

! **IMPORTANT:** Properly complete the warranty registration card; failure to complete and return the card may affect your warranty.

User's Packet



User's Manual

5-Year Warranty & Other Docs

Tail Fin Stickers

Simple Tips for Deep Cycle Battery Bank Sizing



In preparation for battery sizing, know:

ELECTRICAL USAGE - the amount of energy consumed 1 day in Watt-hours (Wh)

DAYS OF AUTONOMY - days of battery back-up required if unable to charge the batteries by any means.

DEPTH OF DISCHARGE - limit of energy withdrawal to which you will subject the deep cycle battery bank.

*Deeper discharge = Shortened battery life.

- *Recommended: never discharge a deep cycle battery below 50% of its capacity.*
- *Off-grid applications, a 25% DoD will extend battery life significantly.*

TEMPERATURE - Standard for most battery rating is 25 °C (77 °F).

Cold temperatures = reduced battery capacity
High temperatures = shortened battery life



RECOMMENDATION - Keep the number of parallel strings of batteries to three or fewer. More than three strings of batteries, risks shortening battery life due to uneven charging.

- *Batteries in Series = Voltage is Additive*
- *Batteries in Parallel = Ah is Additive*

*Example: 2 12V 100Ah Battery Bank

Series	24V	100 Ah
Parallel	12V	200 Ah



CALCULATIONS - calculate battery bank size, use example below:

- *A system load of 6,000 Watt-hours per day*
- *3 Days of Autonomy (back-up) needed*
- *Planned Depth of Discharge (DoD): 40%*
- *Battery bank ambient average low 15.6 °C (60 °F)*
- *A 48V system*

STEPS:	EXAMPLE:																											
1.) <i>Identify total daily use in Watt-hours (Wh)</i>	6,000 Wh/day																											
2.) <i>Identify Days of Autonomy (back-up days); multiply Wh/day by this factor.</i>	3 days of Autonomy: 6,000 x 3 = 18,000 Wh																											
3.) <i>Identify Depth of Discharge (DoD) and convert to a decimal value. Divide result of step 2 by this value.</i>	40% DoD: 18,000 / 0.4 = 45,000 Wh																											
4.) <i>Select the multiplier corresponding to the lowest average temperature your batteries will be exposed to. Multiply result from Step 3 by this factor. *Result is minimum Wh capacity of battery bank:</i> <table border="1" style="margin-left: 20px;"> <thead> <tr> <th colspan="3">Temp in degrees</th> </tr> <tr> <th>°C</th> <th>°F</th> <th>Factor</th> </tr> </thead> <tbody> <tr> <td>26.7</td> <td>80 +</td> <td>1.00</td> </tr> <tr> <td>21.2</td> <td>70</td> <td>1.04</td> </tr> <tr> <td>15.6</td> <td>60</td> <td>1.11</td> </tr> <tr> <td>10</td> <td>50</td> <td>1.19</td> </tr> <tr> <td>4.4</td> <td>40</td> <td>1.30</td> </tr> <tr> <td>1.1</td> <td>30</td> <td>1.40</td> </tr> <tr> <td>-6.7</td> <td>20</td> <td>1.59</td> </tr> </tbody> </table>	Temp in degrees			°C	°F	Factor	26.7	80 +	1.00	21.2	70	1.04	15.6	60	1.11	10	50	1.19	4.4	40	1.30	1.1	30	1.40	-6.7	20	1.59	15.6 °C (60 °F) = 1.11 45,000 x 1.11 = 49,950 Wh
Temp in degrees																												
°C	°F	Factor																										
26.7	80 +	1.00																										
21.2	70	1.04																										
15.6	60	1.11																										
10	50	1.19																										
4.4	40	1.30																										
1.1	30	1.40																										
-6.7	20	1.59																										
5.) <i>Divide result from Step 4 by system voltage. Result is the minimum Amp-hour (Ah) capacity of your battery bank.</i>	49,950 / 48 = 1,040 Ah																											

Battery Configuration and Location



RECOMMENDED:

- Locate battery in moderately stable room temperature, dry unoccupied building.
- If battery is in an occupied building, an enclosure with vent to outside is required. Follow code.
- Batter enclosure:
 - Allow 5 cm (2 in) on all sides for ventilation.
 - Allow 60 cm (2 ft) vertical clearance for maintenance access.
- To minimize the possibility of EMI (electromagnetic interference), the line from the battery to the Whisper Controller should be less than 10 feet (3 m).

Battery Fuse Installation

(Consult local electrical codes)

Battery positive

Nut and bolt

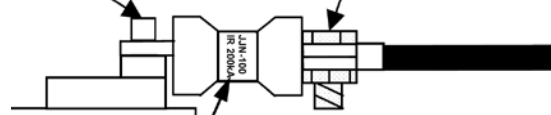

Fuse included (SWWP recommends using a fuse holder to support wire weight)

Use the diagrams below to determine the series/parallel arrangement for your system voltage. Please note: based on 6V batteries.

24 Volt Configuration

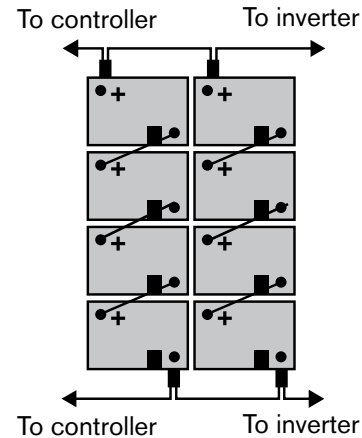

48 Volt Configuration

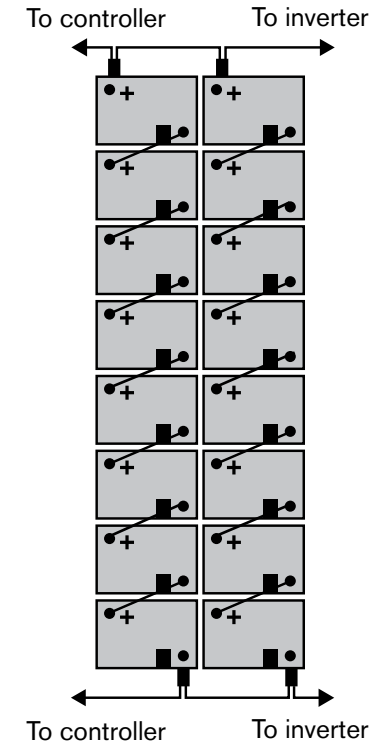

Wind Turbine Electrical Tests

Complete these tests before mounting blades to rotor. These tests confirm the wind generator is ready to install on the tower.

Ground Test



Check resistance to ground on any wire. Resistance must exceed 10,000 ohms; on many digital meters this will show a reading of "OL".

Open Circuit Test

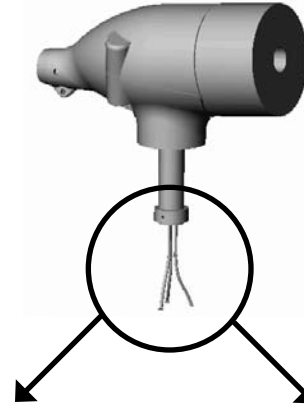

When the wires are unconnected the wind generator rotor should spin freely.

Short Circuit Test



When all the wires are shorted together the alternator should turn hard.

Phase to Phase Test



When **any two wires** are shorted together the alternator should turn lumpy as though there are smooth and bumpy portions of the rotor.

System Wiring

- Select the appropriate size wire to connect the controller to the battery system.
 - 24V System = 6.54 mm (2 AWG) or larger
 - 48V System = 4.11 mm (6 AWG) or larger

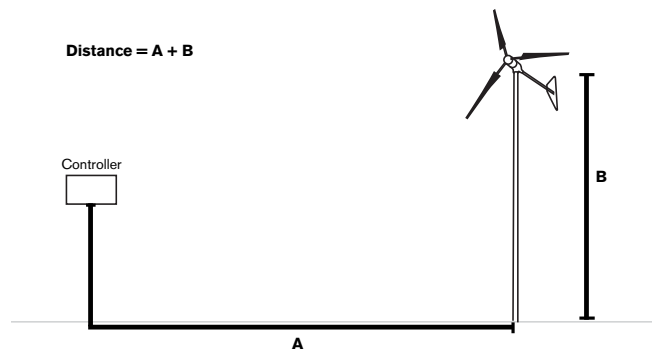

Wire size from wind generator to controller based on voltage configuration and distance (Distance = A + B)

Size	24 V	48 V	230 V
mm ²	Distance*	Distance*	Distance*
–	–	–	–
5.26 mm ² (10 AWG)	–	–	56 m (184 ft)
6.63 mm ² (8 AWG)	–	44 m (145 ft)	89 m (292 ft)
13.29 mm ² (6 AWG)	–	69 m (226 ft)	138 m (453 ft)
21.14 mm ² (4 AWG)	28 m (92 ft)	110 m (361 ft)	220 m (722 ft)
26.65 mm ² (3 AWG)	35 m (115 ft)	139 m (456 ft)	277 m (909 ft)
33.61 mm ² (2 AWG)	44 m (144 ft)	175 m (574 ft)	349 m (1145 ft)
42.38 mm ² (1 AWG)	56 m (184 ft)	223 m (732 ft)	447 m (1467 ft)
53.46 mm ² (0 AWG)	69 m (226 ft)	227 m (909 ft)	554 m (1818 ft)
67.40 mm ² (2/0 AWG)	88 m (289 ft)	352 m (1155 ft)	703 m (2306 ft)
84.97 mm ² (3/0 AWG)	111 m (364 ft)	442 m (1450 ft)	885 m (2904 ft)
107.16 mm ² (4/0 AWG)	140 m (549 ft)	560 m (1837 ft)	1120 m (3675 ft)

*If using aluminum wire, multiply the distances in the table by 0.65.

Distances are one way from the turbine connection to Whisper Controller terminals.



Batteries may emit explosive and irritating gas while charging. Use protective gloves and safety glasses.



Never make any electrical connection, light a match or make a spark near a recently-charged battery.



Turn off all loads, and look away when making a final battery connection.



Whisper 500 HV **CANNOT** be wired directly into the controller. Use a step down transformer set to correct voltage (24, 48) between turbine and controller.



See the Whisper Controller installation section for complete wiring details.



Wire sizes listed in the chart provides a 95% transmission efficiency in 5.4 m/s (12 mph) average wind speed areas.

INSTALLATION SECTION

This section of the manual includes pages 15-31. The pages cover:

Setting Wind Turbine Voltage	15-16
Turbine Assembly	17-20
Mounting Wind Turbine On Tower.....	21-24
Brake Switch Installation	25
Whisper Controller – Mounting.....	26
Whisper Controller – Diversion Load Wiring	27
Transformer Wiring	27
Whisper Controller - Circuit Board Switches and Reset Button.....	28-29
Optional Display Installation.....	31



If it is necessary to print installation instructions, these are the primary pages you will need.

INSTALLATION

Set Wind Turbine Voltage

The Whisper 500 wind turbine and controller must be configured for the correct system voltage - 24 or 48 volts.

- Whisper controllers are shipped from the factory configured for 24 volt operation.
- The correct turbine voltage is set by altering the 12 stator wire and 3 brush wire connections.



IMPORTANT: The stator wires are coated with varnish that **MUST** be removed to make a good connection. Remove varnish by scraping with sharp edge or lightly sandpapering the wire.



- Access wires by removing the cover on the turbine housing.
- The brush wires are interchangeable and not labeled. The brush wires are the larger multi-strand wires; 10AWG.
- The stator wires are numbered and color coded with a wire sleeve. For example stator wire "Red 3" has a red sleeve with the number "3" printed on it. Wire "Red - " has a red sleeve with no number. The "-" indicates there is no number.

*Refer to table on next page for specific stator and brush wire connections.



- Cut off the twisted ends of the stator wires and strip off approximately 25 mm (1 inch) of insulation.
- Hold stripped ends of the wires parallel to each other and twist together clockwise direction before installing the wire nut.

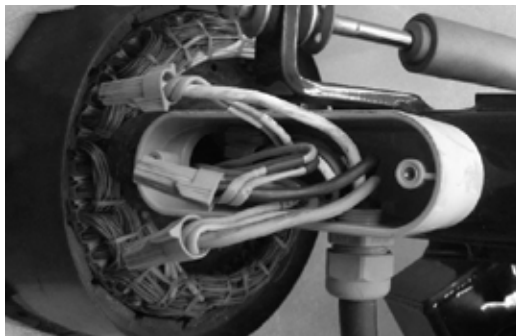

- Trim wires and twist on the appropriate color wire nut (indicated in the table). Push hard on the wire nut while twisting clockwise.
- Coat wire nuts and terminal strip connections with dielectric grease to protect wires against corrosion.

**36V configuration has been removed from this manual. Contact Southwest Windpower technical support for 36V configuration.*

Voltage Configuration Wiring Table

Reference the following table to determine the correct brush and stator wire connections for your voltage configuration.

24* V	Red Wire Nuts			Yellow Wire Nuts	
	Brush Wire	Brush Wire	Brush Wire	White –	White 2
	White 1	Red 2	Black 1	Red 3	Red 1
	White 3	Red –	Black 3	Black –	Black 2

48* V	Red Wire Nuts			Yellow Wire Nuts			
	Brush Wire	Brush Wire	Brush Wire	White –	White 2	Red 2	Black 2
White 1	Red –	Black 1	Red 1 Black –	White 3	Red 3	Black 3	

*For high voltage Whisper, use the 48V configuration for the 240V HV Stator.

Turbine Assembly

Assembly Hardware

- Metric sockets and wrenches required to complete the installation.
- Locate item number in photographs on subsequent pages

Assembly Steps	Item #	Part Description	Qty
1) Tail fin to tail boom	5	M8 x 30 SS bolt	5
	2	M8 x 31 nylon flatwasher	10
	12	M8 SS nylock nut	5
2) Tail Strap to tail boom	8	M8 x 80 SS bolt	1
	1	M8 x 24 SS flatwasher	2
	11	3/4" tube spacer	2
	2	M8 x 31 nylon flatwasher	2
	12	M8 SS nylock nut	1
3) Tail strap to tail fin	9	M8 x 40 SS bolt	2
	1	M8 x 24 SS flatwasher	4
	2	M8 x 31 nylon flatwasher	4
	12	M8 SS nylock nut	2
4) Tail boom to lower weldment	6	M8 x 90 SS bolt	1
	1	M8 x 24 SS flatwasher	2
	5	M8 x 30 SS bolt	2
	12	M8 SS nylock nut	3
5) Blade & blade strap assembly	7	M10 x 80 zinc bolt	8
	13	M10 SS nylock	8
6) Nosecone assembly	3	M8 x 24 nylon flatwasher	2
	1	M8 x 24 SS flatwasher	2
	10	M8 SS Lockwasher	2
	4	M8 x 20 SS hex screw	2

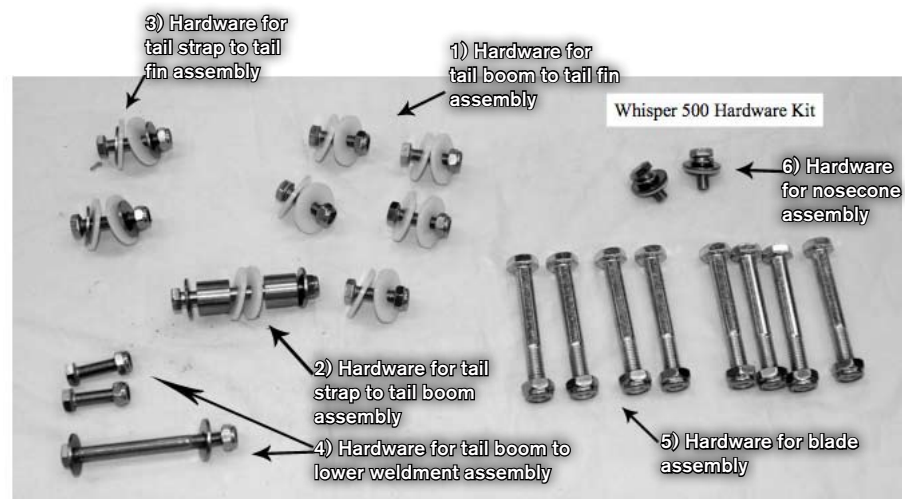

Once Assembled:

- Raise the tower with the brake switch engaged. Follow the tower manufacturer's instructions.
- Turn off brake switch only after:
 - Tower is raised and secured.
 - All systems connections are double checked.



Do not turn on the wind generator if the battery is not properly connected to the controller.



The battery bank must have some charge on it for the wind generator to begin charging i.e. do not connect a dead battery

- Operation of the wind turbine:
 - Wind speeds < 3-4 m/s (7-9 mph) = Turbine will not start from a dead stop.
 - Wind speeds > 3-4 m/s (7-9 mph) = Turbine begins to turn slowly.
 - This is the range where charging current begins.
 - Blade speed momentum will continue to increase depending on wind speed.
 - Once started the turbine will operate in winds as low as 2 m/s (4 mph).

NOTE: Only finger tighten bolts until assembly is complete.

1) Tail Fin To Tail Boom Assembly – 5 Attachment Points (3 for Top Tail Fin, 2 for Bottom Tail Fin)

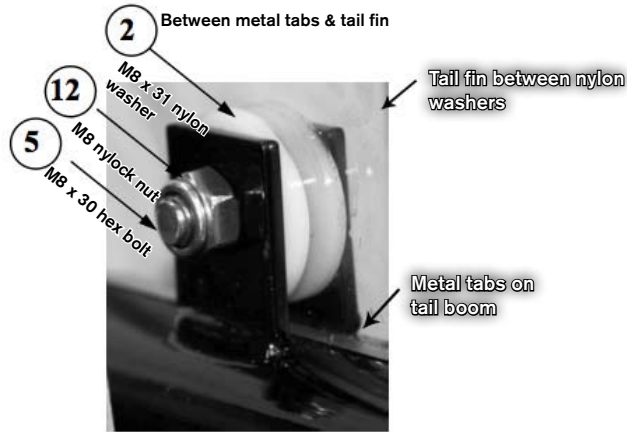

2) Tail Strap To Tail Boom Assembly – 1 Attachment Point on Bottom Fin

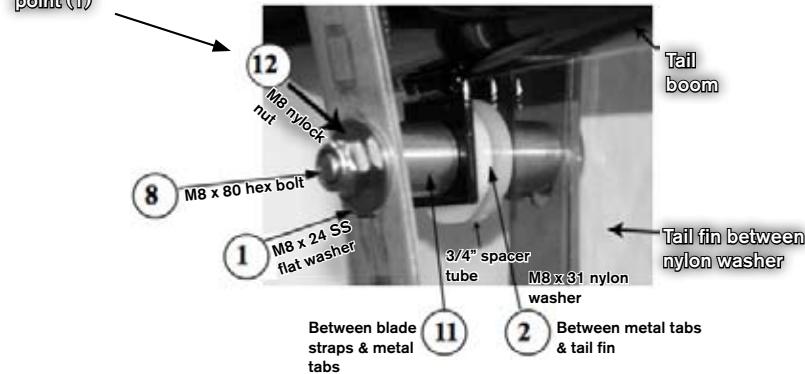
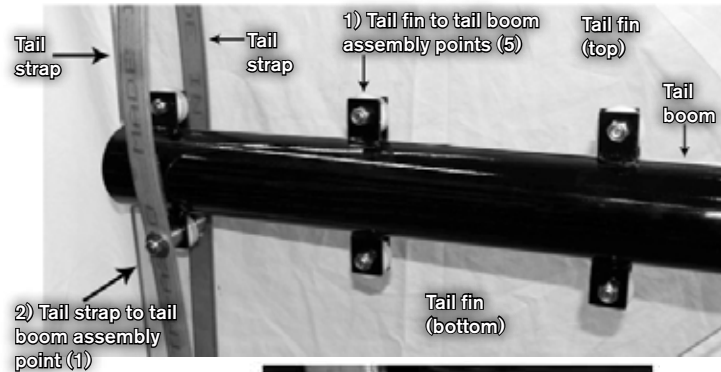

3) Tail Strap To Tail Fin Assembly

- Use a 13mm socket and a wrench to tighten all bolts connecting the tail strap to the tail fin and the tail fin to the tail boom.

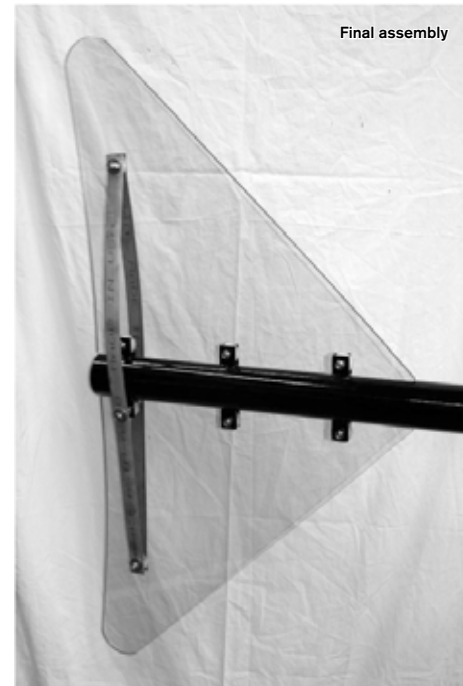
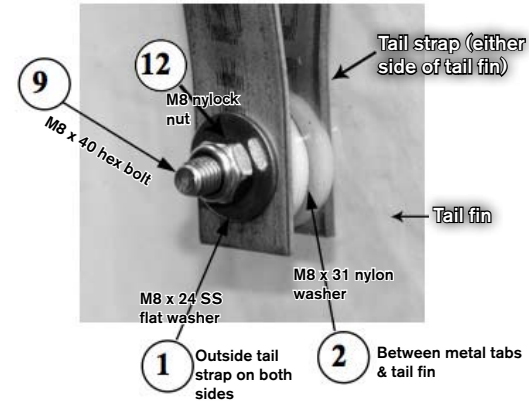

4) Tail Boom To Lower Weldment

Mounting Instructions

- Insert the tail boom into the lower weldment.
- Be sure the tail fins will be vertical when the tower is raised.
- If necessary tap the tail boom into the weldment with a rubber mallet or a piece of wood and a sledgehammer.

NOTE: It may be necessary to drill tail boom hole to achieve perfect alignment.

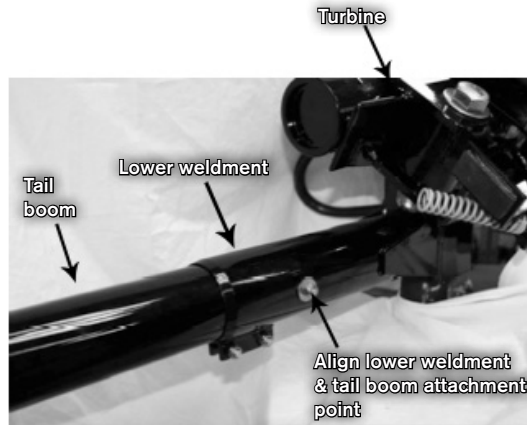

- Install compression bolts on lower weldment, and tighten with 13mm socket and wrench.
- The tail boom should now be securely attached to the lower weldment.

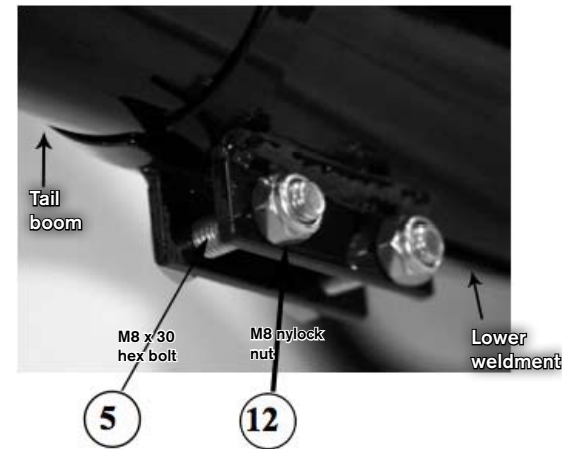

- Install correct hardware (assembly 4) and tighten with 13mm socket and wrench.

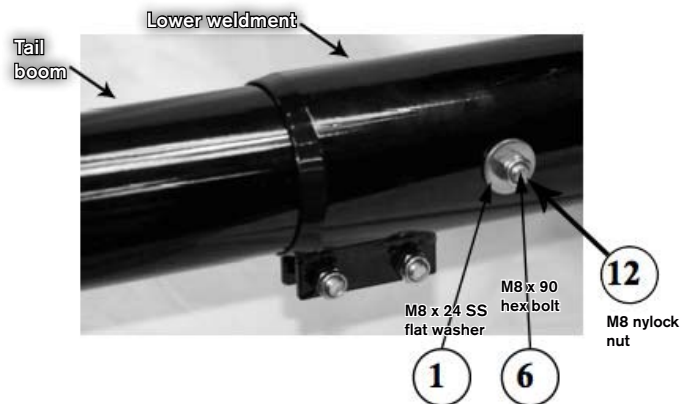

5) Blades & Blade Strap Assembly

- Do not install blades backwards.
- When looking at the front of the turbine from an upwind position:
 - The leading edge tape should be as shown in the picture to the right.
 - Will rotate in a clockwise direction.

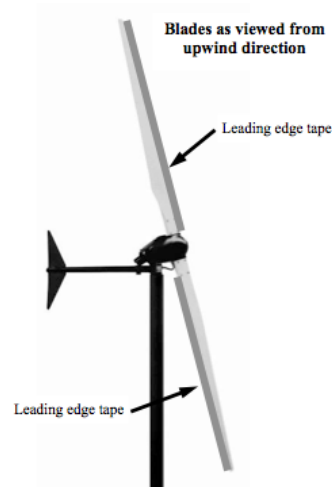
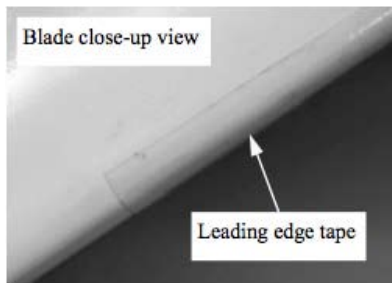

6) Nosecone Assembly

- A removable threadlocking compound should be used on these screws.

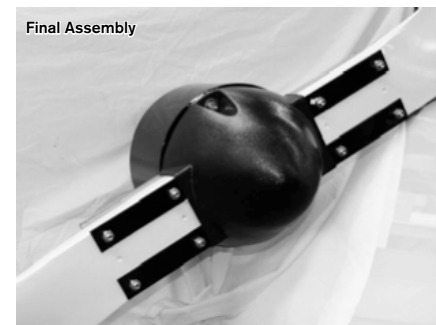
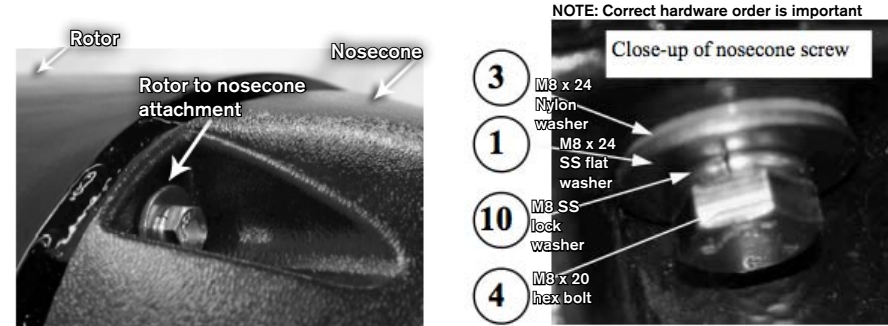

- Make sure threads of the bolts are pointing into the wind.

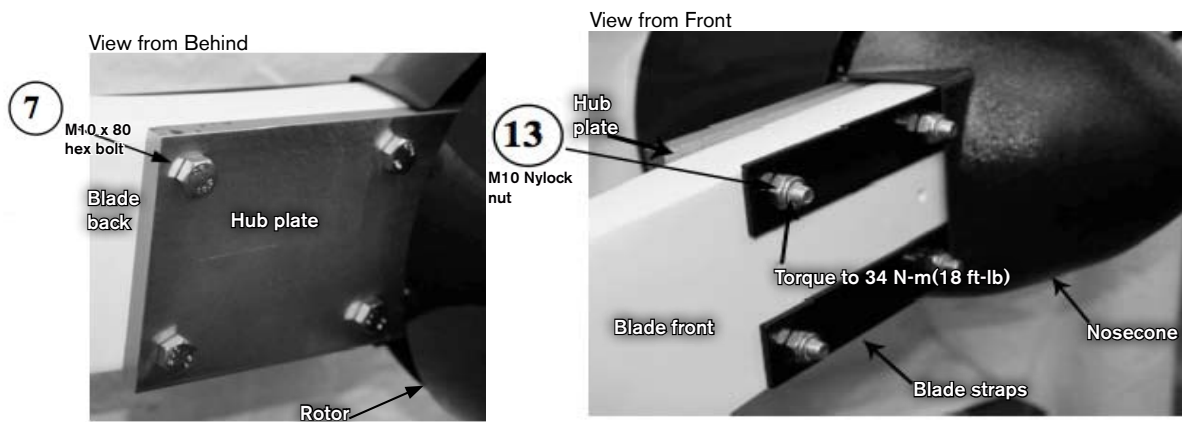

Tower Preparation & Turbine Mounting

Tower Preparation

*There will be a total of 6 holes drilled

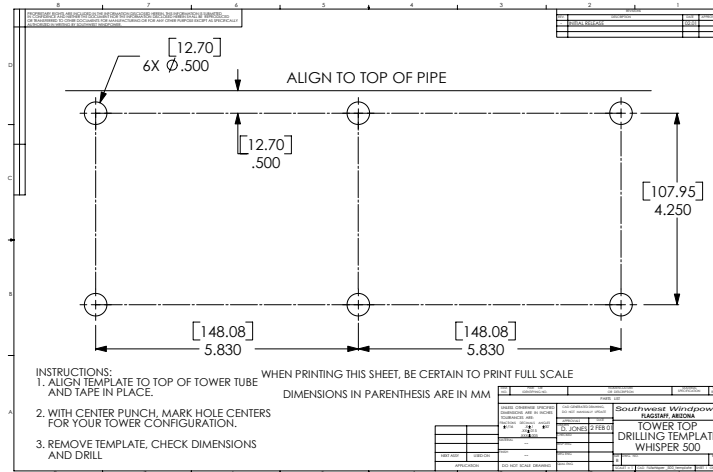

*Ensure all tower to insert holes align while performing fit check.

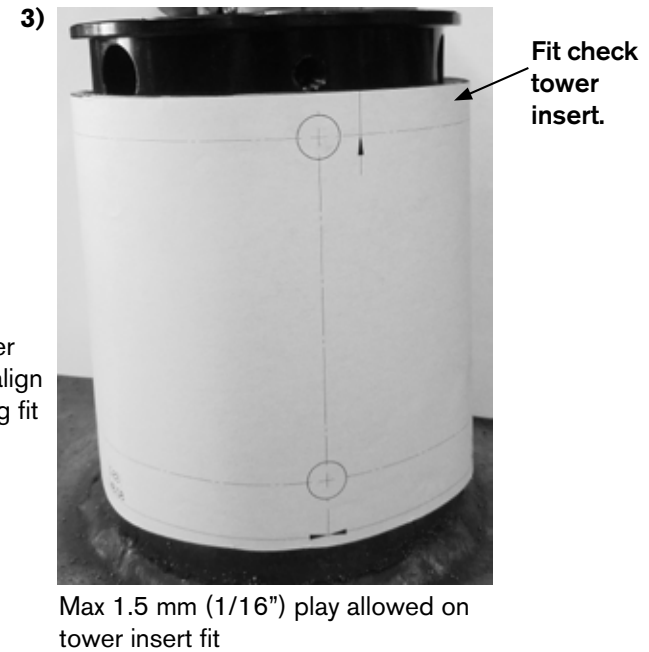

TOWER PREPARATION

4)

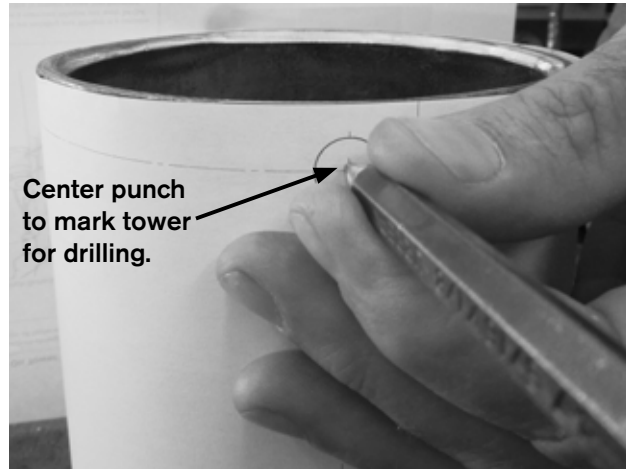

Recommended:
Begin drilling with small bit & work up to 12.7MM (1/2") metal cutting drill bit.

Assembly Hardware

Assembly Step	Item #	Part Description	Qty
1) Tower insert to yaw shaft	1	127 mm (5") Tower insert	1
	2	M10 x 55 Grade 10.9 zinc bolt	3
	3	M10 zinc lockwasher	3
	4	M8 x 30 SS set screw	3
	5	M8 nylock hex nut	3
	6	4mm short arm allen wrench	1
2) Turbine to tower installation	7	M10 x 25 SS hex bolt	6
	8	M10 SS lockwasher	6

5)

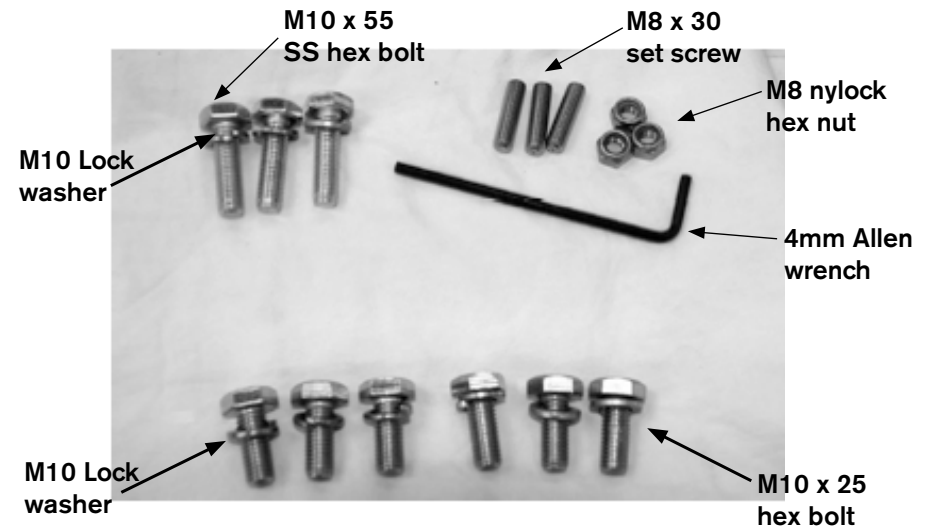
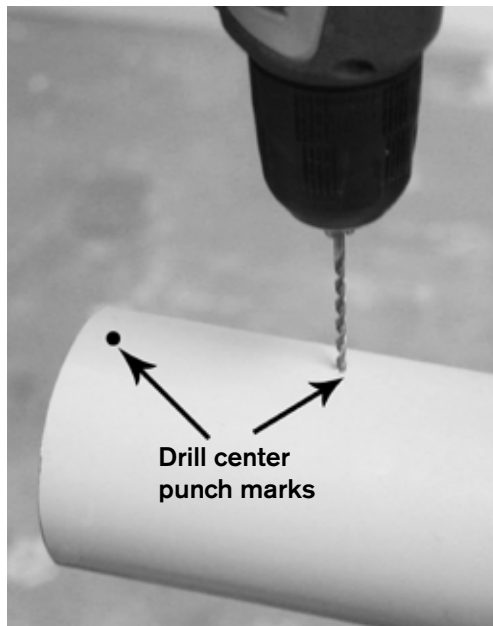

Install Tower Insert on Yaw Shaft



MARINE: If you are installing your Whisper in a corrosive environment, use a marinated Whisper and apply Tef-Gel to all threaded holes to prevent screws from becoming permanently seized into place.

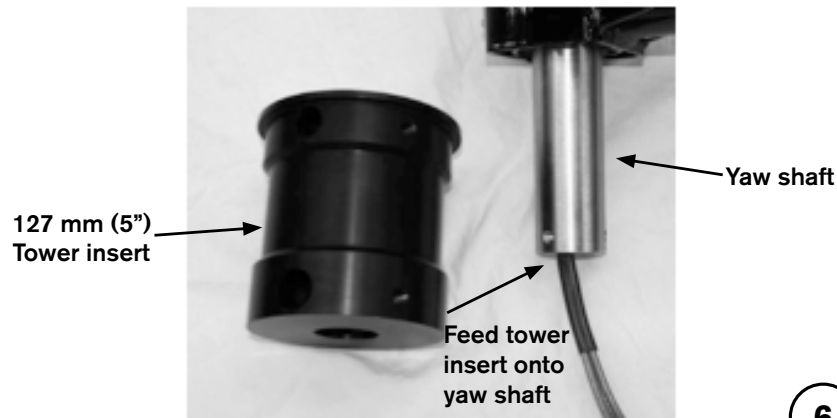

Use medium-strength thread locking compound on all fasteners.

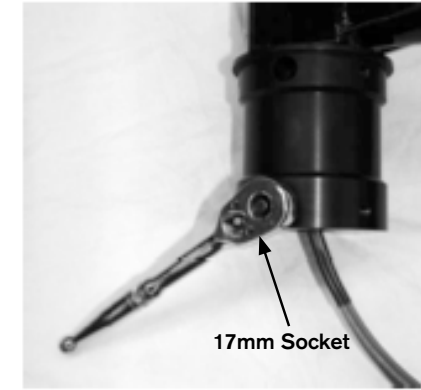

Finger-tighten the nylock nuts over the three M8x30 set screws, before tightening set screw.

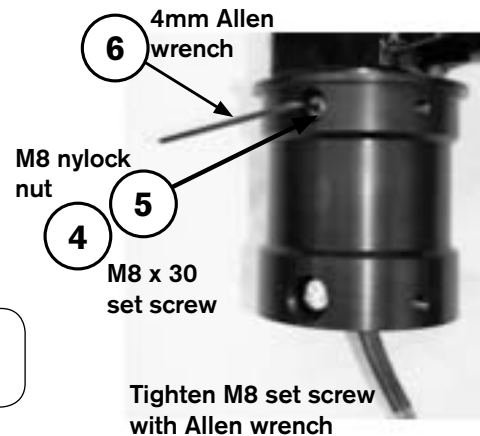

Mount Turbine to Tower

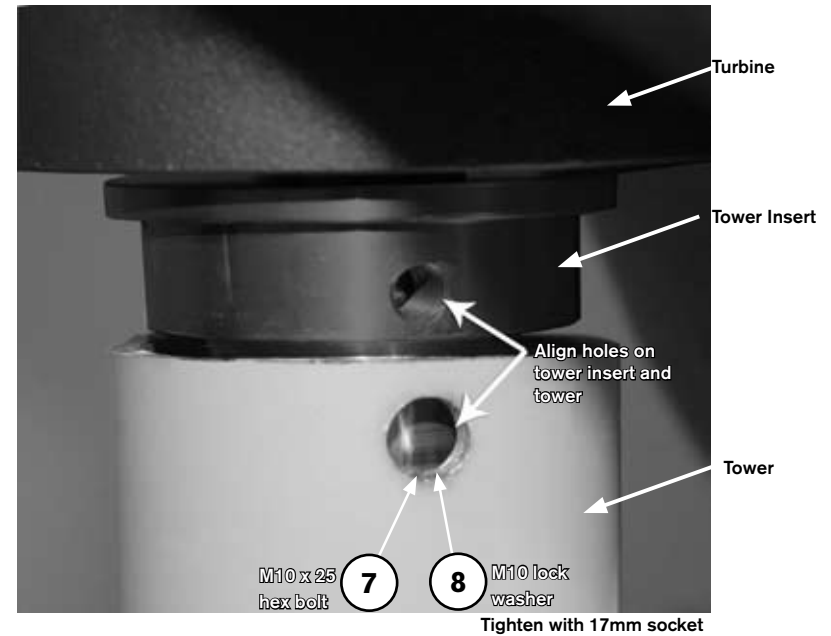
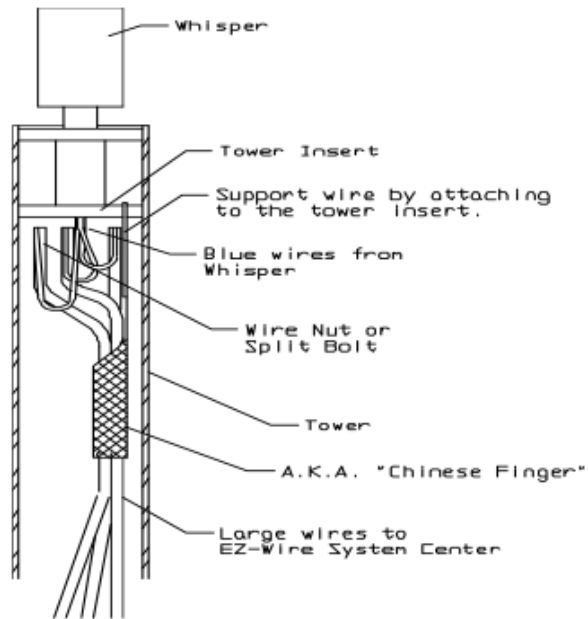

- 1) Solder or use split bolts to make electrical connections.
- 2) Wrap connections thoroughly with electrical tape to prevent shorts to tower.
- 3) Support wires to avoid weight on slip ring wires and wire connections.
- 4) Install turbine without blades being cautious not to pinch wires.

 Tower must be tight against insert when bolts are tightened.

Install Brake Switch

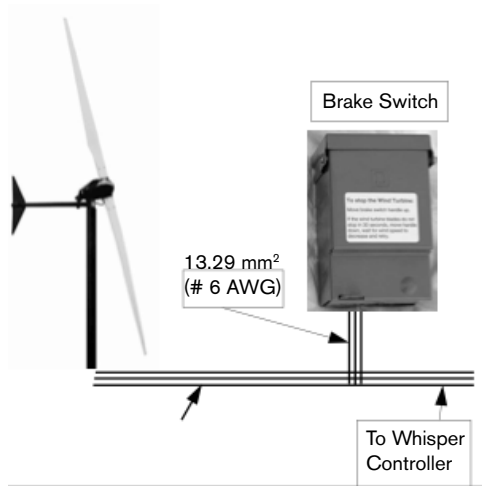

- Mount the brake switch next to the Controller or transformer.
- Connect brake in parallel with three wires between generator and controller or transformer.
- The three wires are connected to the three different terminals indicated on the figure below.

Wire Connection Points

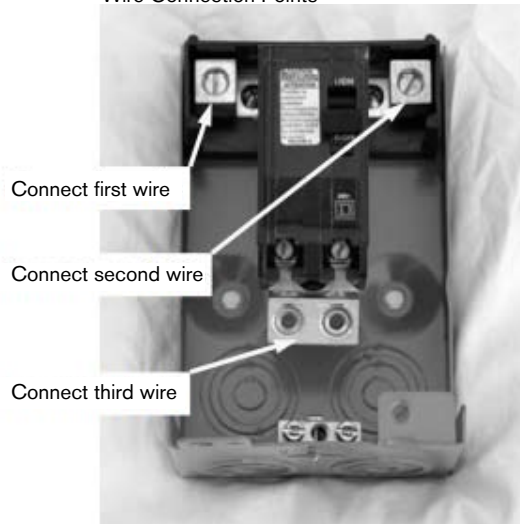

*Wire order is not important.

- The brake switch shorts all three wires together to generate braking torque on the turbine.
- Note: Disregard the original “on” and “off” marking on the switch. Moving the switch up is “brake on”, and moving it down is “normal operation”.



Be certain the switch is between the turbine and transformer, and not between the transformer and Whisper Controller (ie brake switch is on primary side of step-down transformer).



To Stop the Wind Turbine

Move brake switch handle up. If the wind turbine blades do not stop in 30 seconds. Move handle down, wait for wind speed to decrease and retry.



Whisper Controller – Mounting

- When performing preliminary turbine to controller tests, temporarily mounting the controller close to wind turbine allows easy access while testing the turbine and controller functionality.
- Perform turbine to controller tests prior to mounting blades.
- Allow effective heat convection by mounting controller and diversion load vertically against a wall.
- Mount controller within 1.5 m (5 ft) of diversion load due to precut wire length.
- The dump load side of the controller gets very hot, **DO NOT** mount within 3 m (10 ft) of flammable or heat sensitive materials.
- **DO NOT** mount controller above the diversion load.
- Controller and diversion load are **NOT** rated for outside use and must be protected from the elements. Mount inside a protected building.

*Controller can be mounted as shown below, or rotated 90 degrees with dump load on top.

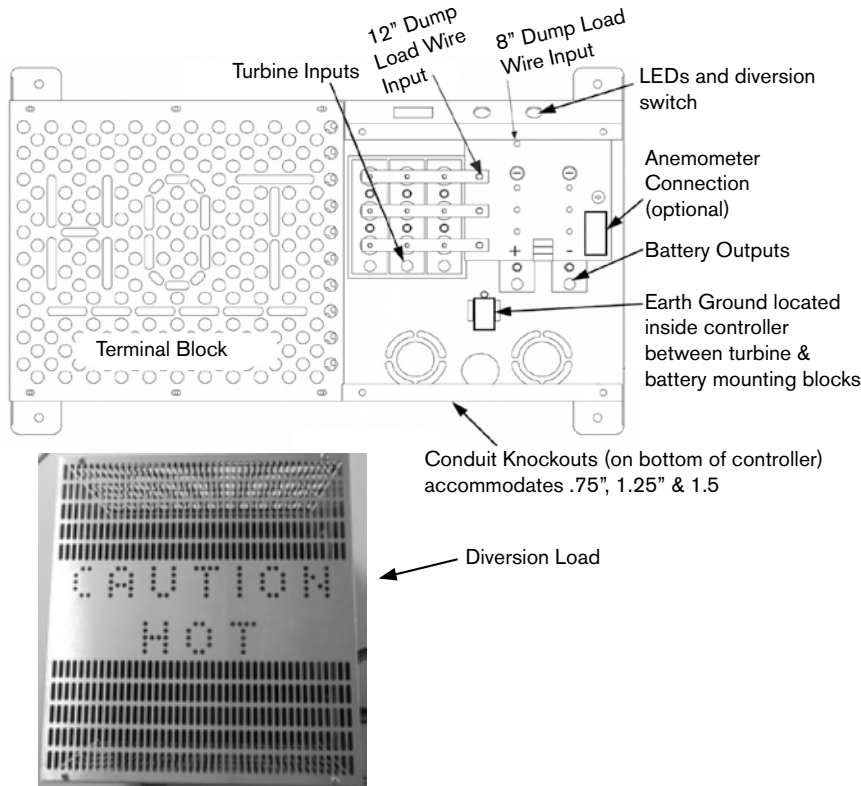

Whisper Controller – Wiring Connecting

Remove the Controller electronic cover and connect the battery, turbine and ground wires as shown on left.

- ❗ Controller **MUST** be connected to the batteries **BEFORE** making the wind turbine connections.
 - ❗ Correct polarity **MUST** be observed when connecting battery cables.
 - Setting dip switch voltages before connecting to battery. See "Printed Circuit Board Switch Settings" section.
 - Avoid shorting battery leads together when connecting the battery.
 - Connect the battery to the controller. Confirm the microprocessor is energized by moving the diversion switch to the "stop" position; red LED should illuminate.
 - If not, momentarily depress the "reset" switch on the controller PCB.
 - Return the diversion switch to the battery position and observe the red LED to turn off.
 - When connecting the battery do not allow the connection to power the microprocessor on and off quickly. This could cause the microprocessor to lock up.
 - If the microprocessor locks up and resetting does not correct the problem, contact Southwest Windpower for instructions.
 - After successful startup, cycle red LED by toggling the diversion switch then switch to "Stop"
 - Connect turbine wires to controller (order is not important)
- *When the red LED is on, the turbine will not spin as long as at least two of its wires are connected, except in strong winds.*

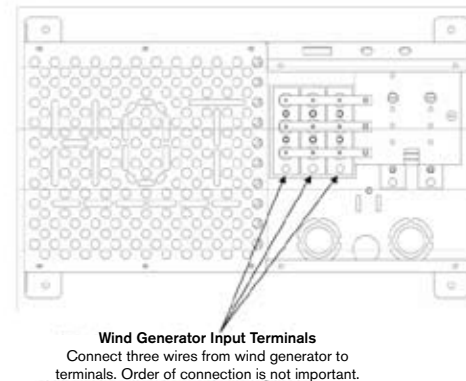

4600 Diversion Load Wiring

- Includes four 10 mm² (8 AWG), labeled Red, Red 1, Black, Black 1, for connection to controller terminal block.

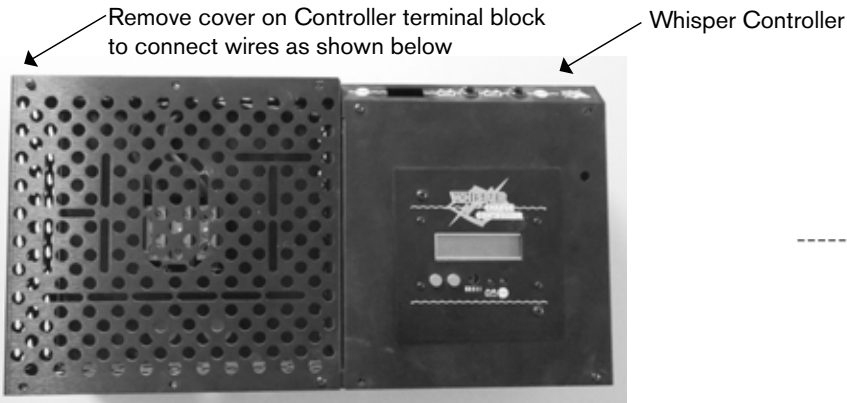

***Be sure to wire for appropriate system voltage.**

Transformer (High Voltage Only)

- Install transformer on heat resistant surface with adequate ventilation.
- The transformer steps down the voltage from 230V to 24 or 48 volts.
- Use chart below to wire transformer for specific voltage

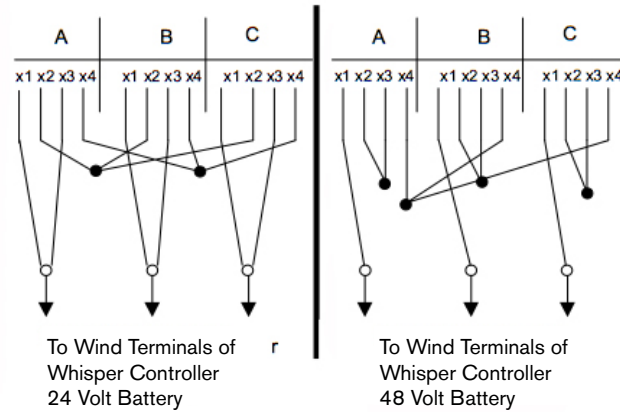
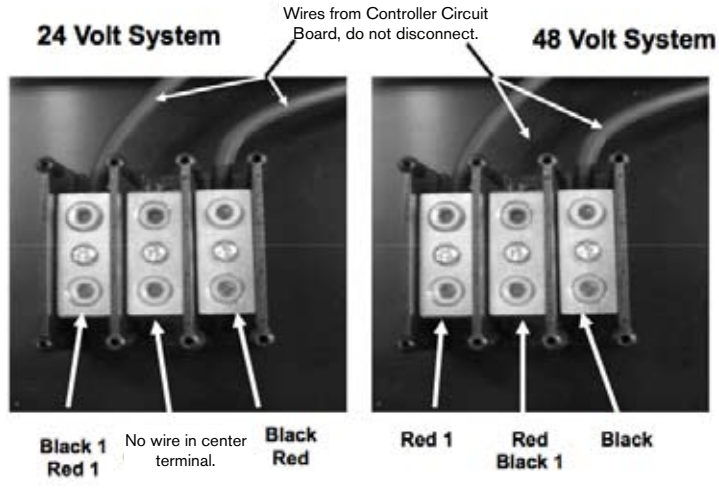
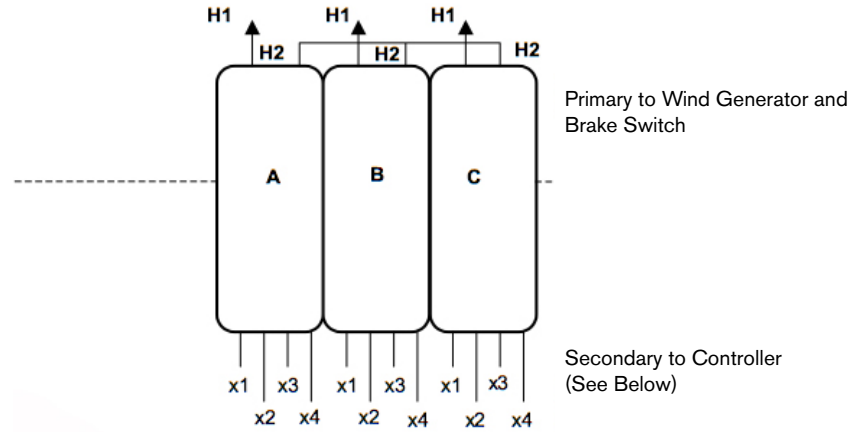

Optional Anemometer Connection

- Whisper Controller is designed to accommodate a model #40 NRG anemometer (www.nrgsystems.com; Item Number 1900).
- Connect anemometer wires to labeled PCB terminal block.
- Anemometers require specific polarity; observe the labeling on the terminal block connections.
- If applicable, connect a grounding shield to the controller's grounding terminal.
- Mount anemometer close to turbine without entering the turbine's swept area (see manufacturer's installation instructions).

Understanding Voltage Regulation:

"Regulation-On"

- Controller is regulating battery voltage and diverting power to the dump load
- If the controller measures battery voltage **above** "regulation-on voltage" for more than 30-40 seconds, it begins diverting power

"Regulation-Off"

- Controller resumes battery charging
- If the controller measures battery voltage **below** "regulation-on voltage" for more than 30-40 seconds, it stops diverting power and begins battery charging

Whisper Controller - Printed Circuit Board Switches and Reset Button

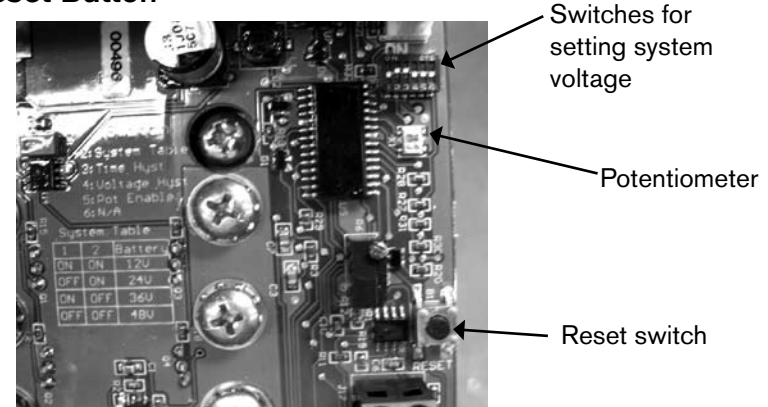

- Six switches on the PCB are used to set operating system parameters.
- The default settings are suitable for most systems installations except two switches **MUST** be changed to alter system voltage.

Reset Switch

- Whisper Controller operation is controlled by a microprocessor.
- The PCB reset switch resets the microprocessor. Depressing the reset switch has the same effect as disconnecting a battery cable.
- To reset momentarily press the reset button. If it is necessary to depress a second time, wait approximately 15 seconds.
- **Voltage regulation points set using the optional display setting will be lost if reset switch is depressed or a battery cable is disconnected; controller will revert to potentiometer set points.**

Printed Circuit Board Switch Settings

Switches 1 and 2, System Voltage

Select the correct system voltage by setting the position of switches 1 and 2 according to the following table.

System Voltage	Switch 1	Switch 2
24 Volt	OFF	ON
48 Volt	OFF	OFF

After changing the system voltage depress the reset switch to “read and save” the new voltage setting.

Switch 3 , Time Hysteresis, Default Setting “ON”

ON	30-40 second delay for controller to start or stop charging when regulation set point is reached
OFF	No-delay – charging will stop or start immediately when regulation set point is reached

It is not necessary to depress the Reset Switch after changing the switch setting.

***Southwest Windpower STRONGLY recommends Switch 3 remain in ON position**

Switch 4, Voltage Hysteresis, Default Setting “OFF”

OFF	Controller starts or stops charging at the voltage regulation points set through optional display or by the PCB potentiometer
ON	Voltage regulation-on point (battery stops charging) set using potentiometer increases by: <ul style="list-style-type: none"> - 2.0 volts for 24V systems - 4.0 volts for 48V systems Voltage regulation-off point (battery charging resumes) is not affected Voltage hysteresis switch does not increase the regulation on and off set points using the optional display

Switch 5, Potentiometer Enable, Default Setting “OFF”

ON	Enables reading potentiometer voltage in real time. Resolution limits are: <ul style="list-style-type: none"> - 0.4 volts for 24V systems - 0.8 volts for 48V systems Voltage regulation points must be set using potentiometer not optional display
OFF	Prevents changing the voltage regulation point using the potentiometer

It is not necessary to Reset after changing the switch 4 & 5 settings.

Before adjusting the Voltage Regulation-On set-point understand that increasing the voltage will not increase the turbine’s output voltage or current. This set-point only adjusts the “shut-down” voltage for battery charging. Overcharging will significantly reduce a battery’s life expectancy.

Switch 6, Default Setting “OFF”

There is no function presently associated with this switch. SWWP recommends leaving the switch in the OFF position.

OPERATION AND ADJUSTMENTS

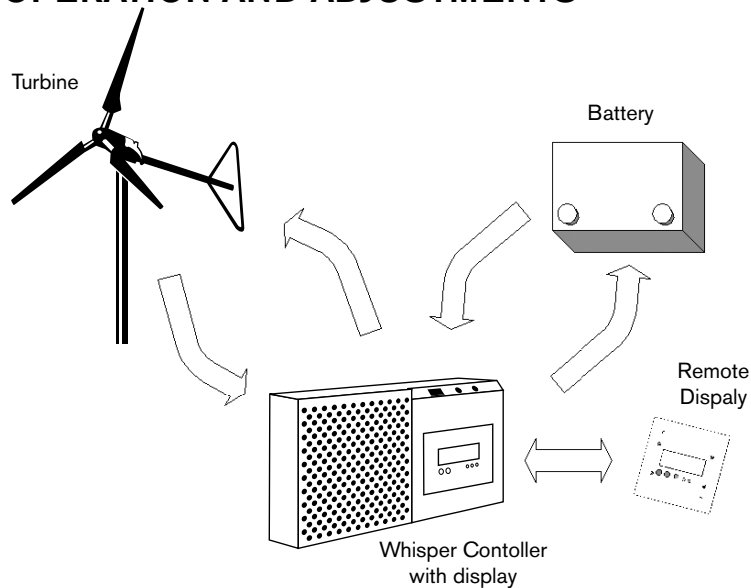

Whisper Controller Components

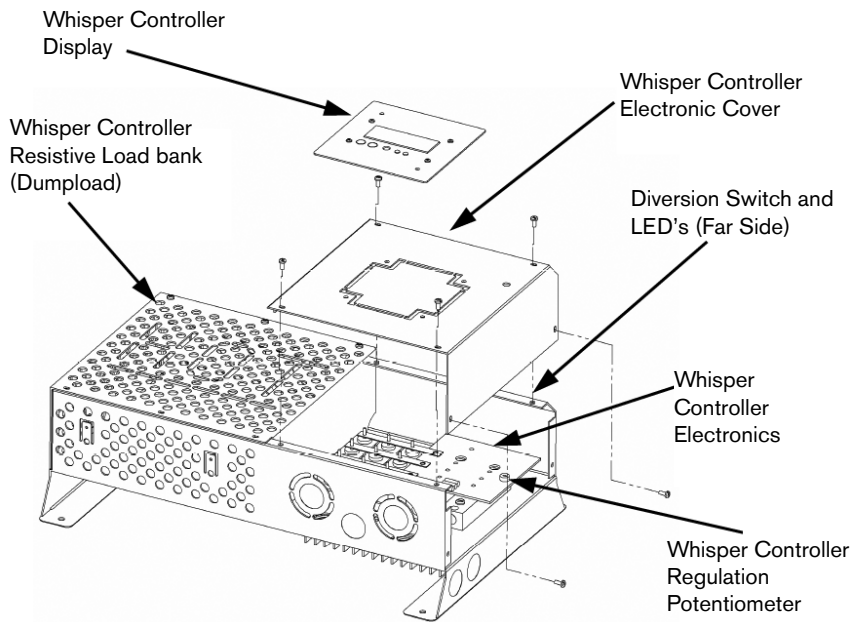

Operation of the Whisper Controller

1) Overview

- Controls and converts turbine power. Functions:
 - Rectifies power from wild AC to DC voltage
 - Contains diversion load & controls voltage regulation
 - Monitors voltage, current, energy production and wind speed (if equipped)
- Optional LCD Display:
 - Offers instant access to operational parameters and performance measurements; voltage, current, power, energy, charge, peak power and wind speed (if equipped)
 - Display LEDs function same as controller LED

2) Normal Operation

- Interface mechanisms: LED, diversion switch, voltage regulation adjustment, PCB configuration switches and LCD display (if equipped)
- Interface allows setting regulation voltage, monitoring system

3) Diversion Switch

- Diverts power from batteries to dump load to avoid battery overcharging
- Considerations if activated:
 - Will not stop a spinning turbine but will not allow a stopped turbine to start spinning
 - If turbine blades are spinning, it is normal and safe

4) LED Operation

Red LED = Power diverted to dump load;
Green LED = Turbine is charging battery

LED INDICATORS		
RED	GREEN	INTERPRETATION
OFF	ON	Battery charging
BLINKING	OFF	Power to diversion load to regulate battery voltage
ON	OFF	Power to diversion load by operator request (via Diversion Switch or remote Display).

5) Setting Regulation Voltage (without Display) *See page 22 - Switch 5

- Turning the potentiometer clockwise (CW) increases the voltage set points. Use following chart for approximate potentiometer set points.

Note: Determine the initial potentiometer position by turning fully counter clockwise (CCW). Count and record the number of turns.

Pot Position	Regulation Off Voltage	Regulation On Voltage
Fully CCW	24.0v 36.0v 48.0v	13.0V 26.0v 39.0v 52.0v
1/4 Turns CCW	13.0V 26.0v 39.0v 52.0v	14.0V 28.0v 42.0v 56.0v
Factory Preset	13.4V 26.8v 40.2v 53.6v	14.4V 28.8v 43.2v 57.6v
1/2 Turns CW	14.0V 28.0v 42.0v 56.0v	15.0V 30.0v 45.0v 60.0v
3/4 Turns CW	14.0V 28.0v 42.0v 56.0v	16.0V 32.0v 48.0v 64.0v
Fully CW (18 turns)	14.0V 28.0v 42.0v 56.0v	17.0V 34.0v 51.0v 68.0v

6.) Whisper Controller Display (Optional)

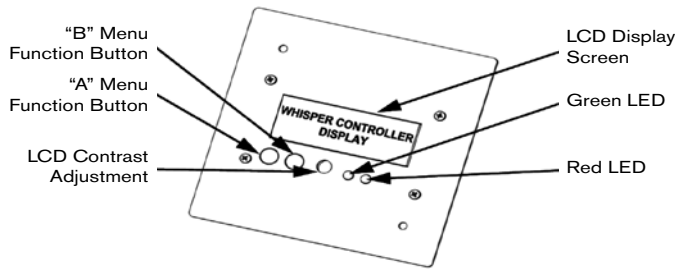

- Designed to mount on:
 - Whisper controller base unit (a short CAT5 Ethernet cable is provided) or 4" wall type switch receptacle
- If mounted on controller, connect CAT5 to jack closest to diversion switch to disable controller LED
- Mounting on Whisper Controller
 - Remove electronics cover
 - Remove sheet metal insert where display will mount
 - Use hardware provided to mount display to electronics cover
 - Hardware: 8-32 x 3/8" black oxide SS screws and 8-32 nuts with captive star washers
- If mounted remotely, the display can be mounted up to 300 m (1,000 ft) from controller; longer CAT5 cable must be purchased by user.

- Verify display function: text should appear on LCD display after display and batteries are connected to controller.
- It may be necessary to adjust LCD contrast:
 - Locate small hole between buttons and LEDs
 - Insert small screwdriver through display cover
 - Turn clockwise to lighten
 - Turn counter-clockwise to darken
- If text is still not visible, disconnect & reconnect cable to display to reset.

Display Menu Ring Structure

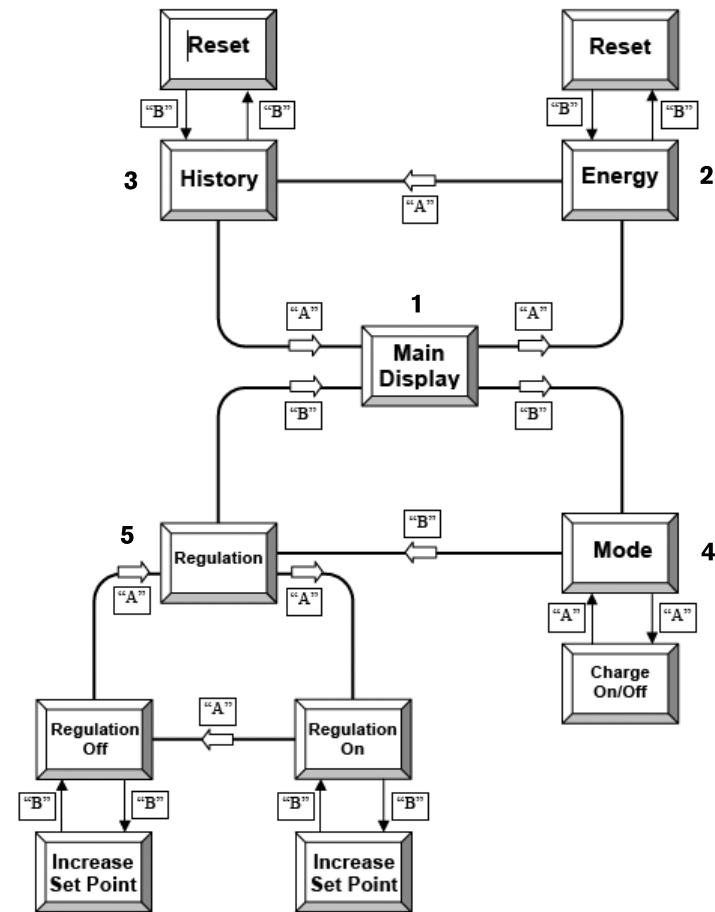

Display Menu Functions

Ref #	Page	Display			Menu Select	Effect
1	Main	On or Off		00.0 mph	"A"	go to A ring
		11.3V	00.0A	000W	"B"	go to B ring
A Ring						
2	Energy	KWh	0000	000.00	"B"	go to reset menu
	Reset Menu	kAh	0000	000.00		
		Reset kWh?	A: RESET	B: CANCEL	"A"	reset power
					"B"	return to reset menu
3	History	Mph:	00.0a	00.0p	"B"	go to reset menu
		pow:	00.0a	00.0p		
	Reset Menu	Reset Page?	A: RESET	B: CANCEL	"A"	reset readings
					"B"	return to reset menu
B Ring						
4	Mode	Mode:	On		"A"	batteries charging
		A: OFF_REM	B: SKIP		"B"	go to regulation set menu
		Mode:	Off		"A"	batteries diverted
		A: ON_REM	B: SKIP		"B"	go to regulation set menu
5	Regulation Set	REGULATION SET:			"A"	change regulation point
		A: CHANGE	B: SKIP		"B"	return to Main Menu
	Regulation On	Regulation ON voltage:			"A"	go to regulation off menu
			15.8v		"B"	Increase ON set voltage
	Regulation Off	Regulation OFF voltage:			"A"	go to regulation set menu
			12.8V		"B"	Increase OFF set voltage

1) Main Page

- Displays controller's measurements: battery charging status, voltage, and current and turbine power and windspeed (if equipped)
- Leads to four sub-pages by selecting "A" or "B" functions
 - "A" – Energy and History menu pages
 - "B" – Mode and Regulation menu pages

2) Energy Page

- Displays accumulated kWh and kAh since last reset
- Accumulated data can be reset by selecting menu option "B"
- Menu option "A" goes to the History page

3) History Page

- Displays average and peak windspeed and turbine power since reset
 - Note: windspeed is only available if anemometer is installed
- Reset accumulation data by selecting menu option "B"
- Menu option "A" goes to the Main Display page

4) Mode Page

- Displays current charge mode
 - If "ON" is displayed the battery can be charged; turbine will spin in adequate wind
 - If "OFF" is displayed turbine power produced is diverted to dump load; turbine will not spin in light winds
 - "A" menu button toggles the mode
 - "B" menu button returns to Regulation Set page
- Controller can switch to "OFF" mode in the following conditions
 - "OFF_REM" - turbine power is diverted to dump load via request from remote display
 - "OFF_MAN" - turbine power is diverted to dump load when diversion switch is moved to "Stop" position
 - "OFF_REG" - turbine power is diverted to dump load via automatic regulation at present voltage

*Diversion switch set to "OFF" overrides Remote Display "ON" function

5) Regulation Page

Digitally set "regulation on" and "regulation off" voltages using the Regulation Setpage Menu

- Select "A: CHANGE" for "Regulation ON" subpage for voltage changes
 - "B" menu button increases voltage to 17V maximum. At 17V, if pressed again, the voltage rolls back to 13V
 - "A" menu button brings up "Regulation OFF" subpage
 - "B" menu button increases voltage to a maximum of one volt lower than "Regulation ON" voltage. At maximum, if pressed again, the voltage rolls back to 12V
 - "A" menu button returns to Regulation Set page
 - Select "B:SKIP" to return to Main Display Page
- *Regulation Off voltage cannot be specified above Regulation On voltage

MAINTENANCE AND REPAIR

Maintenance – Monthly

1) Test Brake (check electrical wiring)

- Divert the load by setting the diversion switch to “stop” in a moderate wind (charging but not furling)
- No unusual difficulty or noise should be experienced in stopping the blade rotor
- A noise during diversion can indicate a disconnected wire
- **If the blades do not stop within 30 seconds of activating the brake, then turn it back “on” and try again later when there is less wind. Attempting to stop the turbine in high winds can damage the alternator.**

2) Check Mechanical Condition

- Watch and listen from the tower base. There should be no mechanical noise, rattle or vibration and the blades and tail must not wobble
- If you hear mechanical noise, rattle or vibration, or see blade or tail wobble, lower the tower for inspection
- If you experience any of these conditions, refer to Troubleshooting and Repair

3) Inspect the Tower

- Follow all inspection and maintenance requirements of the tower manufacturer
- Tighten all nuts and bolts, especially wire clips
- Check for cracks and bent/broken parts at the anchors and base
- Check for broken strands and tighten wires

4) Check the Battery

- Consult your battery manufacturer maintenance guide
- Tighten battery connections
- Remove corrosion and protect terminals

Maintenance - Annual

Lower the tower and give wind generator a complete inspection. Fix or replace any worn or loose parts.

- Check tightness of all tower and blade nuts and bolts
- Check all bearings
- Clean the blades with a mild detergent to remove all dirt and debris.
 - Replace blades if they are cracked or damaged
 - Replace missing leading edge tape
 - Fill small surface cracks with silicone sealant
 - Rebalance blades after modifications

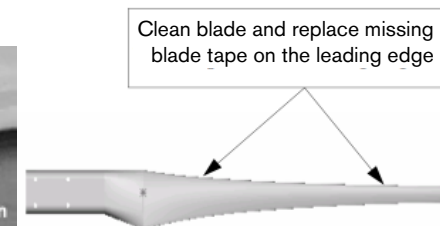
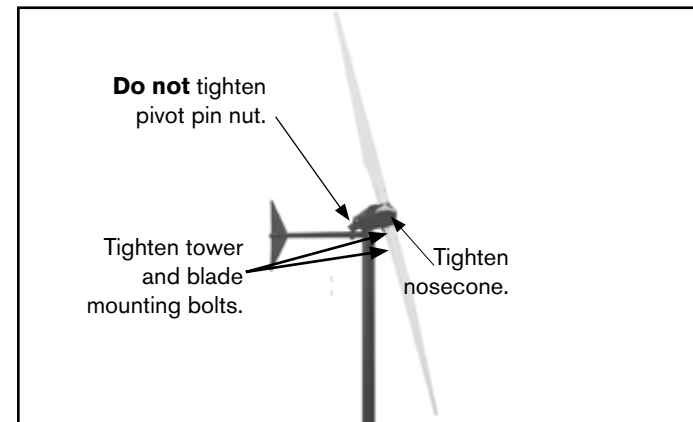

Troubleshooting and Repair

Table: Symptoms of Mechanical Problems

Symptom	Probable Cause	Correction
Blade rotor is stationary, even in high winds	<ul style="list-style-type: none"> a) Ice in generator, or on blades b) Debris between rotor and stator c) Loose, broken or rubbing magnet d) Bad or worn bearing 	<ul style="list-style-type: none"> a) Wait for warm weather. Leave running unless vibration is substantial b) Turn blades gently by hand and use thin material to dislodge debris c) Remove rotor and re-glue magnets – contact factory/ dealer/ distributor d) Contact factory or distributor
Blade rotor will not turn at all except in high wind, scraping or rubbing sound at low rpm, always stops at same blade position	<ul style="list-style-type: none"> a) Same as above, except more likely to be high magnet or bad bearing. b) Swelled wire keepers due to high moisture 	<ul style="list-style-type: none"> a) Same as above b) Contact factory/ dealer/ distributor – stator needs revarnishing
Blade rotor is hard to start, output is lower & there is more blade noise than usual; appears out of balance.	<ul style="list-style-type: none"> a) Ice on blades b) Dirty blades c) Eroded or damaged leading edge tape d) Split, warped or damaged blades e) One or both blade(s) on backwards 	<ul style="list-style-type: none"> a) Wait for warm weather. Leave running unless vibration is substantial b) Clean with mild detergent c) Refinish blade or replace tape d) Replace damaged blade – contact factory/ dealer/ distributor e) See blade installation
Blade rotor turns slowly, never spins rapidly	<ul style="list-style-type: none"> a) Blades on backwards. 	<ul style="list-style-type: none"> a) See blade installation
Tail, generator and tower vibrate or shake excessively at all or some wind speeds SAFETY FIRST - shut down turbine until a physical inspection can be performed.	<ul style="list-style-type: none"> a) Blade out of balance b) Blade not tracking c) Rotor out of balance d) Blade plate out of balance e) Shorted alternator or wiring 	<ul style="list-style-type: none"> a) Balance or replace blade – contact factory/ dealer/ distributor b) Shim at mounting bolts – contact factory/ dealer/ distributor c) Replace mounting plate – contact factory/ dealer/ distributor d) Contact factory/ dealer/ distributor e) Perform phase-to-phase testing
Rattle or clunking from generator SAFETY FIRST - shut down turbine until a physical inspection can be performed.	<ul style="list-style-type: none"> a) Generator loose in tower. Rotor loose on shaft, loose tail, missing rubber bumper, wires slapping inside of mast, governor pivot bolt loose b) Worn bearings c) Shaft broken 	<ul style="list-style-type: none"> a) Inspect for damage and repair as required Retighten mounting hardware, use Loctite or equivalent thread-locking compound. b) Replace bearings – contact factory/ dealer/ distributor c) Replace shaft – contact factory/ dealer/ distributor

Electrical Diagnosis - Determining the Type of Electrical Problem

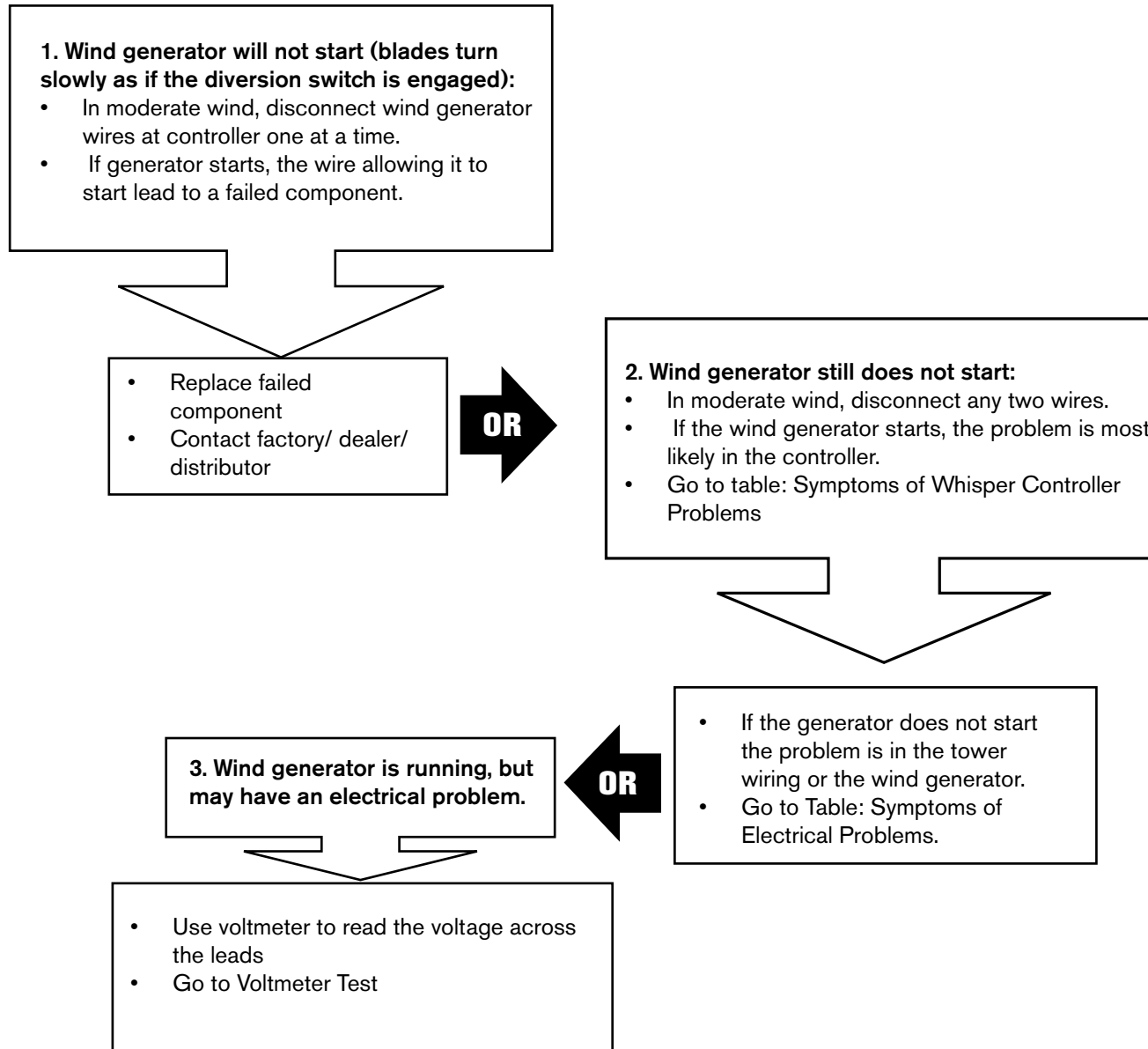

Voltmeter Test

Test	What it tells you
1. Voltage increases and decreases slowly relative to wind speed across all combinations of paired wires	<ul style="list-style-type: none"> Everything is OK.
2. No voltage across one set of two wires	<ul style="list-style-type: none"> One wire from the wind generator is not carrying power. Check the tower wiring and controller connections to ensure proper wiring. If the wiring is correct contact authorized factory/ dealer/ distributor for further assistance.
3. Voltage significantly higher across one set of two wires than the others	<ul style="list-style-type: none"> Possibly a shorted diode. Contact factory/ dealer/ distributor.
4. Voltage significantly lower across one set of two wires than the others	<ul style="list-style-type: none"> There is a bad connection at wind turbine voltage connections or faulty stator winding. Contact factory/ dealer/ distributor.

Should these results appear inconclusive in determining the problem proceed directly to Table: Symptoms of Electrical Problems or see Table: Symptoms of Whisper Controller Problems below.

Table: Symptoms of Whisper Controller Problems

Symptom	Probable Cause	Correction
Blade rotor turns slowly, even in strong wind	<ul style="list-style-type: none"> a) Brake switch ON b) Shorted diode c) Dead or disconnected battery d) Short in wiring to turbine 	<ul style="list-style-type: none"> a) Move switch to "OFF" b) Contact factory/ dealer/ distributor c) Ensure battery voltage at controller terminals is at least 10v, 20v, 32v, or 44v depending on turbine model d) See Table of Electrical Problems
Doesn't regulate, red LED off and dump load is cold	<ul style="list-style-type: none"> a) Battery volts below setting b) Bad circuit board 	<ul style="list-style-type: none"> a) Check battery with voltmeter (see Voltmeter Test). Adjust voltage setting b) Contact factory/ dealer/ distributor
Doesn't regulate, red LED on and dump load is cold	<ul style="list-style-type: none"> a) Dump load burned out, disconnected or wired incorrectly b) Bad connection from circuit board to power block 	<ul style="list-style-type: none"> a) Contact factory/ dealer/ distributor b) Contact factory/ dealer/ distributor
Dumplload always on, red LED on	<ul style="list-style-type: none"> a) Wrong battery voltage setting b) Bad circuit board c) Diversion switch set to "Stop" or disconnected 	<ul style="list-style-type: none"> a) Check battery with voltmeter (see Voltmeter Test) Adjust voltage setting b) Contact factory/ dealer/ distributor c) Move diversion switch to "Start". Check and restore connection, if needed

Table: Symptoms of Electrical Problems

Symptom	Probable Cause	Correction
Blade rotor will not turn or turns slowly, even in high wind	<ul style="list-style-type: none"> a) Brake is ON. b) Battery is dead (voltage less than 1/2 nominal) c) Incorrect turbine wiring. d) Short circuit in wiring from generator to controller e) Failed component in controller f) Short circuit in brush card or slip ring assembly g) Short circuit in turbine 	<ul style="list-style-type: none"> a) Turn brake OFF b) Disconnect load and /or battery from generator until it starts; charge battery c) See "Wind Turbine Electrical Connections" d) Check wiring from generator to controller e) See Voltmeter Test f) See "Brushes and Brush Holders" – contact factory/ dealer/ distributor g) Contact factory/ dealer/ distributor
Blade rotor runs too fast, may whistle; no output, no unusual mechanical noise	<ul style="list-style-type: none"> a) Two or three wires open between turbine and controller b) Controller diodes open or wire is disconnected at diode terminal c) Battery voltage over 50% d) Incorrect generator connection e) Load or battery disconnected 	<ul style="list-style-type: none"> a) See Voltmeter Test b) See Voltmeter Test c) Examine battery specifications and regulation set point. Replace batteries if necessary d) See "Wind Turbine Electrical Connections" e) Check all connections
Blade rotor runs too fast, may whistle, output less than 50% for wind speed, growling , buzzing or vibration felt by hand or mast	<ul style="list-style-type: none"> a) Disconnect wire between turbine and controller b) One open or disconnect diode c) One slip ring or brush not making good contact d) Incorrect generator wiring 	<ul style="list-style-type: none"> a) See Voltmeter Test b) See Voltmeter Test c) See "Brushes and Brush Holders" – contact factory/ dealer/ distributor d) See "Wind Turbine Electrical Connections"
Blade rotor runs too slowly, low output, no unusual mechanical noise	<ul style="list-style-type: none"> a) Battery voltage low or dead battery b) Incorrect turbine wiring 	<ul style="list-style-type: none"> a) Disconnect loads and let battery charge b) See "Wind Turbine Electrical Connections"
Green charge light comes on momentarily during wind gusts or only comes on in very high wind conditions	<ul style="list-style-type: none"> a) The turbine and controller voltage settings may be set to different voltage configurations 	<ul style="list-style-type: none"> a) Verify the turbine output wiring, the diversion load and the controller DIP switch are configured to the same voltage

Whisper Wind Turbine Warranty Agreement

Hardware Warranty

Southwest Windpower, Inc., (“Southwest Windpower”) will repair or replace free of charge any part or parts of the Southwest Windpower Whisper™ Wind Turbine determined by Southwest Windpower to be defective in materials and/or workmanship under normal authorized use consistent with product instructions for a period of five years from the date the original purchaser (“Customer”) receives the Wind Turbine (“Start Date”). This warranty extends only to the original purchaser. The Customer’s sole and exclusive remedy and the entire liability of Southwest Windpower, its suppliers and affiliates under the warranty is, at Southwest Windpower’s option, either (i) to replace the Wind Turbine with new or reconditioned Wind Turbine, (ii) to correct the reported problem, or (iii) to refund the purchase price of the Wind Turbine. Repaired or replaced products are warranted for the remainder of the original warranty period.

Restrictions

Problems with the Wind Turbine Products can be due to improper use, lack of maintenance, non-Southwest Windpower additions or modifications or other problems not due to defects in Southwest Windpower’s workmanship or materials. No warranty will apply if the Wind Turbine (i) has been altered or modified except by Southwest Windpower, (ii) has not been installed, operated, repaired, or maintained in accordance with instructions supplied by Southwest Windpower, (iii) has been exposed to winds exceeding 120 mph (54 m/s), (iv) or has been subjected to abnormal physical, thermal or electrical stress, misuse, negligence, or accident. If Southwest Windpower’s repair facility determines that the problem with the Wind Turbine is not due to a defect in Southwest Windpower’s workmanship or materials, then the party requesting warranty service will be responsible for the costs of all necessary repairs and expenses incurred by Southwest Windpower.

Warranty Claims & Return Procedures

In order to be eligible for service under this warranty the Customer MUST return the warranty registration card included with this Warranty Agreement within 60 days of purchasing the Wind Turbine. Additionally, the Customer must submit a service request for Wind Turbine covered by this warranty within the warranty period by contacting Southwest Windpower in writing or via telephone and obtaining a Return Authorization (“RA”) number. This RA must be obtained before returning any product under this warranty.

Notification must include a description of the alleged defect, the manner in which the Wind Turbine was used, the serial number, and the original purchase date in addition to the name, address, and telephone number of the party requesting warranty service. Within 3 business days of the date of notification, Southwest Windpower will provide the Customer with a RA number and the location to which the Customer must return the defective Wind Turbine. Any Wind Turbine requiring warranty repair shall be transported at the expense and risk of the party requiring warranty service, including but not limited to proper packaging of the Product. The Customer must return the entire Wind

Turbine kit within 30 days after issuance of the RA number. Southwest Windpower will be under no obligation to accept any returned Wind Turbine that does not have a valid RA number. Customer’s failure to return the Wind Turbine within 60 days of its receipt of a RA number may result in cancellation of the RA. All parts that Southwest Windpower replaces shall become Southwest Windpower’s property on the date Southwest Windpower ships the repaired Wind Turbine or part back to the Customer. Southwest Windpower will use all reasonable efforts within five days of receipt of the defective Wind Turbine to repair or replace such Wind Turbine. If a warranty claim is invalid for any reason, the Customer will be charged at Southwest Windpower’s then-current rates for services performed and will be charged for all necessary repairs and expense incurred by Southwest Windpower.

Disclaimer

EXCEPT FOR THE EXPRESSED WARRANTY SET FORTH ABOVE, SOUTHWEST WINDPOWER DISCLAIMS ALL OTHER EXPRESSED AND IMPLIED WARRANTIES, INCLUDING THE IMPLIED WARRANTIES OF FITNESS FOR A PARTICULAR PURPOSE, MERCHANTABILITY AND NON-INFRINGEMENT. NO OTHER WARRANTY, EXPRESSED OR IMPLIED, WHETHER OR NOT SIMILAR IN NATURE TO ANY OTHER WARRANTY PROVIDED HEREIN, SHALL EXIST WITH RESPECT TO THE PRODUCT SOLD UNDER THE PROVISIONS OF THESE TERMS AND CONDITIONS. SOUTHWEST WINDPOWER EXPRESSLY DISCLAIMS ALL LIABILITY FOR BODILY INJURIES OR DEATH THAT MAY OCCUR, DIRECTLY OR INDIRECTLY, BY USE OF THE PRODUCT BY ANY PERSON. ALL OTHER WARRANTIES ARE EXPRESSLY WAIVED BY THE CUSTOMER.

Limitation of Liability

UNDER NO CIRCUMSTANCES WILL SOUTHWEST WINDPOWER OR ITS AFFILIATES OR SUPPLIERS BE LIABLE OR RESPONSIBLE FOR ANY LOSS OF USE, INTERRUPTION OF BUSINESS, LOST PROFITS, LOST DATA, OR INDIRECT, SPECIAL, INCIDENTAL, OR CONSEQUENTIAL DAMAGES, OF ANY KIND REGARDLESS OF THE FORM OF ACTION, WHETHER IN CONTRACT, TORT (INCLUDING NEGLIGENCE), STRICT LIABILITY OR OTHERWISE, RESULTING FROM THE DEFECT, REPAIR, REPLACEMENT, SHIPMENT OR OTHERWISE, EVEN IF SOUTHWEST WINDPOWER OR ITS AFFILIATE OR SUPPLIER HAS BEEN ADVISED OF THE POSSIBILITY OF SUCH DAMAGE. (Note: some states and provinces do not allow the exclusion or limitation of incidental or consequential damages, so these limitations may not apply to you). Neither Southwest Windpower nor its affiliates or suppliers will be held liable or responsible for any damage or loss to any items or products connected to, powered by or otherwise attached to the Hardware. The total cumulative liability to Customer, from all causes of action and all theories of liability, will be limited to and will not exceed the purchase price of the Product paid by Customer. This Warranty gives the Customer specific legal rights and the Customer may also have other legal rights that vary from state to state or province to province.



Southwest Windpower Inc.
1801 West Route 66
Flagstaff, Arizona 86001 USA
t: +1 928.779.9463
f: +1 928.779.1485

www.windenergy.com

Southwest Windpower GmbH
Mannesmannstr. 6
50996 Cologne Germany
t: +49 (0) 221 16 53 94 50