

PV GROUND FAULT PROTECTION – HOW IT WORKS

NORMAL OPERATING CONDITION

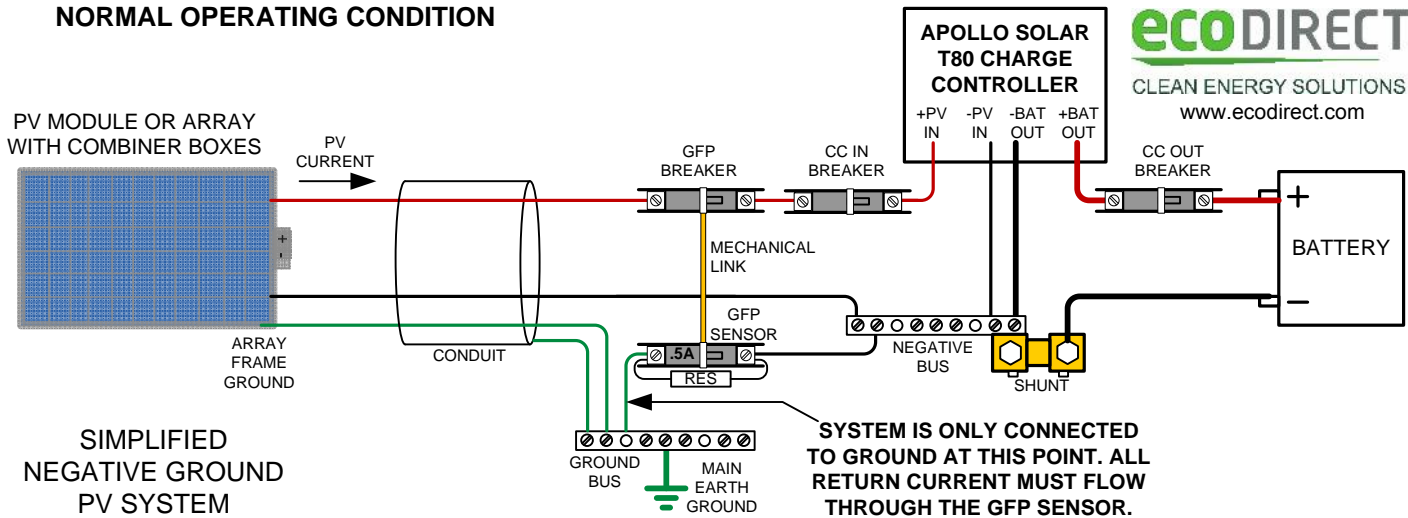

ecodirect
CLEAN ENERGY SOLUTIONS
www.ecodirect.com

GROUND FAULT IN THE POSITIVE WIRE (PROTECTION REQUIRED BY UL1741 AND NEC)

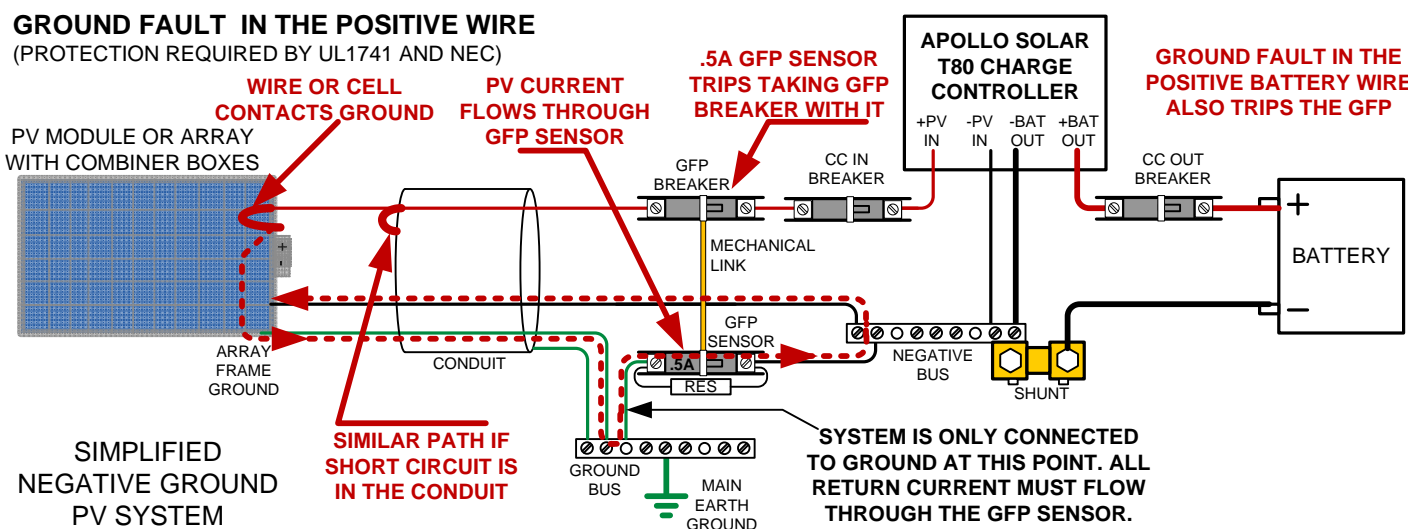

GROUND FAULT IN THE NEGATIVE WIRE (PROTECTION REQUIRED BY UL1741, NOT NEC)

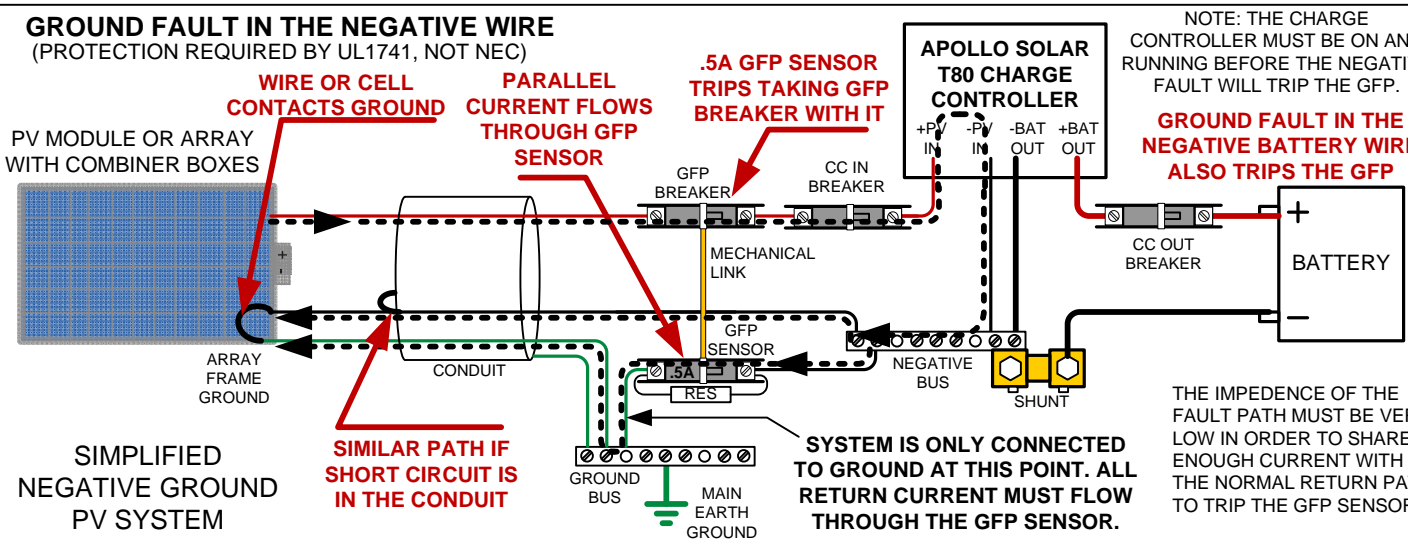

NOTE: THE CHARGE CONTROLLER MUST BE ON AND RUNNING BEFORE THE NEGATIVE FAULT WILL TRIP THE GFP.

GROUND FAULT IN THE NEGATIVE BATTERY WIRE ALSO TRIPS THE GFP

THE IMPEDENCE OF THE FAULT PATH MUST BE VERY LOW IN ORDER TO SHARE ENOUGH CURRENT WITH THE NORMAL RETURN PATH TO TRIP THE GFP SENSOR.

NEC 690.5 states that the Ground Fault Protection device must:

- 1) Detect a ground fault
- 2) Interrupt the fault current
- 3) Indicate that there was a ground fault
- 4) Open the ungrounded PV conductors

The drawing shows that each of the NEC requirements are satisfied with this GFP device.

The system may be tested by forcing a short to the ground wire near the PV array. It is wise to use a current limiting resistor to create the short to limit damage to the wires. Be careful of high PV voltage.



APOLLO SOLAR

23 F. J. Clarke Circle
Bethel, CT 06801
(203) 790-6400
www.ApolloSolar.com

HOW IT WORKS

GROUND FAULT PROTECTION

9-JULY-10	J. PFEIFER	
-----------	------------	--