

CORNELL
UNIVERSITY
LIBRARY



FROM

The Estate of S. Simpson

Cornell University Library
QP 34.P371 1910

Practical physiology.



3 1924 003 128 729

mann

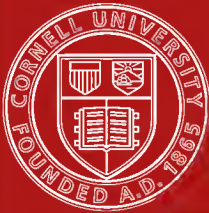

Cornell University Library

The original of this book is in
the Cornell University Library.

There are no known copyright restrictions in
the United States on the use of the text.

PRACTICAL PHYSIOLOGY

PRACTICAL PHYSIOLOGY

EDITED BY
M. S. PEMBREY

CONTRIBUTORS

- | | |
|---|--|
| A. P. BEDDARD, M.A., M.D.
Assistant Physician, late Demonstrator of Physiology, Guy's Hospital | LEONARD HILL, M.B., F.R.S.
Lecturer on Physiology, The London Hospital |
| J. S. EDKINS, M.A., M.B.
Lecturer on Physiology, St. Bartholomew's Hospital | J. J. R. MACLEOD, M.B.
Professor of Physiology, Western Reserve University, Cleveland, U.S.A. |
| MARTIN FLACK, M.A., M.D.
Demonstrator of Physiology, London Hospital | M. S. PEMBREY, M.A., M.D.
Lecturer on Physiology, Guy's Hospital |

ILLUSTRATED BY NUMEROUS DIAGRAMS AND TRACINGS

THIRD EDITION

NEW YORK
LONGMANS, GREEN, & CO.
LONDON: EDWARD ARNOLD

1910

PREFACE TO THE FIRST EDITION.

PHYSIOLOGY is the basis of medicine, and the further advance of these sciences depends mainly upon the "experimental method." The medical student, the future physician, should undergo a training in practical physiology, for thereby he learns the most important of all lessons; he learns to observe, to draw conclusions from his observations, and to unravel the causes of his failures.

The importance of practical physiology is undoubted, but as to the nature and scope of the experimental work, which is most suitable for the medical student, there is considerable difference of opinion among teachers of physiology. In this country, perhaps, too much stress has been laid upon the physiology of muscle and nerve; for the hope that a study of the properties of these tissues will unfold the enigma of life is likely ever to remain without consummation.

An advance in the knowledge of the living organism as a whole, one organ reacting upon another, has been gained by experiments upon the living animal, treated as a unit and not as a collection of separate organs and tissues. Such practical physiology needs extension in the courses of instruction given to students. It should, as far as possible, have a direct relation to medicine.

The methods which are used in the investigation of the respiratory system, the circulation, the body heat, the nervous system and special senses; the chemistry of the blood, of digestion, and of urine—these are the subjects which are especially required by the clinician. These subjects, moreover, afford as excellent a mental training as the study of muscle and nerve.

In the present work the authors have attempted to give some extension to practical physiology along the lines just indicated.

The book has been divided into an elementary and an advanced portion. Part I. treats of elementary experimental physiology (the physiology of muscle and nerve, circulation, respiration, animal heat,

the central nervous system, and the special senses); Part II. of elementary physiological chemistry; Part III. of advanced experimental physiology; and Part IV. of advanced physiological chemistry.

The experiments upon the physiology of muscle and nerve are based upon the course given at Guy's Hospital—a course modelled on a reduced scale upon the excellent practical courses given at Oxford by Professor Burdon Sanderson and Professor Gotch. The experiments in this section have been limited as far as possible to those which can be conveniently performed with simple apparatus by a large class of students. For this reason the experiments with the galvanometer and capillary electrometer have been restricted to demonstrations, and very few details of such experiments are given.

There are some important experiments upon the circulation and respiration, which for various reasons cannot be properly performed by the student; these have been collected together as demonstrations in Parts I. and III.

The subject of vision is so important from a medical as well as a physiological and psychological point of view, that it has here received more extensive treatment than is usually the case in works on practical physiology.

In those portions of the book which treat of physiological chemistry, an attempt has been made to demonstrate, step by step, the chemical relationships which exist between the various substances, and to illustrate, by suitable experiments, the different properties of those bodies. The drawings of crystals were executed by Mr. W. R. M. Turtle, to whom the authors are deeply indebted.

Figures have been borrowed from *The Physiological Action of Drugs*, by M. S. Pembrey and C. D. F. Phillips. For the loan of numerous blocks illustrating physiological apparatus the authors are indebted to Messrs. Baird & Tatlock, of Hatton Garden, E.C. The sources of other diagrams and tracings, which have been borrowed, are indicated in the description of the figures. The initials of the author, who took the record of the original tracings, are appended to the respective curves.

Sept., 1902.

PREFACE TO THE SECOND EDITION.

IN the present edition considerable changes have been made in those portions of the work which deal with Physiological Chemistry. The new exercises have involved a slight increase in the total number of pages, and several new figures have been added.

July, 1905.

PREFACE TO THE THIRD EDITION.

THE present edition is in many respects a new book, for many parts have been rewritten and the arrangement of the whole has been altered. The book now consists of two parts, Part I., which deals with Experimental Physiology, and Part II., which is devoted entirely to Physiological Chemistry.

The experiments upon muscle and nerve have been reduced in number and the observations which can be made upon man have been increased.

The Authors wish to thank Drs. H. D. Haskins and J. H. Ryffel for their able assistance in the revision of the chapters on Physiological Chemistry and Dr. Kennaway for many criticisms and suggestions upon the whole of the work.

Dr. Hertz has contributed a special chapter upon the "Investigation of the Motor Functions of the Alimentary Canal by means of the X-Rays," and Dr. Ryffel one upon "Lactic Acid, its Estimation and Significance." For this valuable assistance hearty thanks are given.

Sept., 1910.

CONTENTS.

PART I.

MUSCLE AND NERVE. CIRCULATION. RESPIRATION.
ANIMAL HEAT. CENTRAL NERVOUS SYSTEM
AND SPECIAL SENSES.

By A. P. BEDDARD, J. S. EDKINS, L. HILL, and M. S. PEMBREY.

CHAP.	PAGE
Introduction, -	1
I. Electrical Apparatus for Physiological Experiments. By A. P. B.,	2
II. The Graphic Method. Maximal and Minimal Stimuli. Uni- polar Excitation. By A. P. B.,	14
III. A Single Contraction of a Gastrocnemius Muscle. By A. P. B.,	22
IV. The Conditions which affect Single Muscular Contractions. By A. P. B.,	29
V. The Conditions which affect Single Muscular Contractions (<i>continued</i>). By A. P. B.,	32
VI. The Conditions which affect Single Muscular Contractions (<i>continued</i>). By A. P. B.,	35
VII. Two Successive Stimuli. Genesis of Tetanus. Tetanus. By A. P. B.,	40
VIII. The Properties of Nerve, Minimal and Maximal Stimuli. By M. S. P., -	44
IX. The Relation between Muscle and Nerve. By M. S. P.,	48
X. The Effect of a Constant Current upon Muscle and Nerve. By M. S. P.,	50
XI. The Electromotive Properties of Muscle and Nerve. By M. S. P.,	51
XII. Extensibility and Elasticity of Muscle when at Rest and Contracted. Comparison with Rubber (<i>Advanced</i>). By A. P. B.,	53

CHAP.	PAGE
XIII. Load and After-load. Work done with Increasing Loads (<i>Advanced</i>). By A. P. B.,	57
XIV. Summation of Stimuli (<i>Advanced</i>). By A. P. B.,	62
XV. Effect of Distilled Water and of Various Salts on Muscle (<i>Advanced</i>). A. P. B.,	67
XVI. Fatigue of a Voluntary Movement and of a Muscle-Nerve Preparation with its Circulation intact (<i>Advanced</i>). By A. P. B.,	70
XVII. The Rate of Transmission of a Nervous Impulse (<i>Advanced</i>). By M. S. P.,	76
XVIII. The Polarisation of Electrodes and Unpolarisable Electrodes (<i>Advanced</i>). By M. S. P.,	78
XIX. Transmission of a Nervous Impulse in both Directions (<i>Advanced</i>). By M. S. P.,	79
XX. The Relation between Muscle and Nerve. The Independent Excitability of Muscle (<i>Advanced</i>). By M. S. P.,	80
XXI. The Effect of a Constant Electrical Current upon the Excitability and Conductivity of Nerve (<i>Advanced</i>). By M. S. P.,	81
XXII. The Absence of Fatigue in a Stimulated Nerve (<i>Advanced</i>). By M. S. P., -	87
XXIII. The Electromotive Properties of Muscle and Nerve (<i>Advanced</i>). By M. S. P.,	88
XXIV. The Electromotive Properties of Muscle and Nerve (<i>continued</i>). The Galvanometer and the Capillary Electrometer (<i>Advanced</i>). By M. S. P.,	90
XXV. The Anatomy of the Frog's Heart and its Contraction. By L. H.,	92
XXVI. Methods of Recording the Heart. By L. H.,	97
XXVII. The Stannius Heart. By L. H.,	100
XXVIII. The Cardiac Nerves and Ganglia. By L. H.,	103
XXIX. The Sino-auricular Junction. The Action of Drugs. By L. H.,	109
XXX. The Effect of Nicotine, Chloroform, and Ether upon the Heart. By L. H.,	112
XXXI. Dissection of the Heart. The Cardiac Impulse. By L. H.,	115
XXXII. The Pulse. Human Blood Pressure. By L. H.,	121
XXXIII. Blood. The Haemoglobinometer and the Haemacytometer. By L. H.,	128

CHAP.	PAGE
XXXIV. Circulation of the Blood (<i>Elementary Demonstrations</i>). By L. H.,	131
XXXV. The Heart (<i>Advanced</i>). By L. H.,	149
XXXVI. The Heart (<i>continued</i>). The Action of Drugs. By L. H.,	151
XXXVII. Gaskell's Clamp and the Effect of Local Warmth on the Heart (<i>Advanced</i>). By L. H.,	154
XXXVIII. Action of the Cardiac Nerves (<i>Advanced</i>). By L. H.,	156
XXXIX. The Pulse (<i>Advanced</i>). By L. H.,	161
XL. Vaso-motor System (<i>Advanced</i>). By L. H.,	164
XLI. Intracardiac Pressure. Blood Flow (<i>Advanced Demonstrations</i>). By L. H.,	166
XLII. Effect of Haemorrhage and Saline Transfusion (<i>Advanced Demonstrations</i>). By L. H.,	171
XLIII. Respiration. By M. S. P.,	174
XLIV. Intrathoracic Pressure. By L. H.,	176
XLV. Ventilation of the Lungs. The Spirometer and the Stethograph. By M. S. P.,	177
XLVI. Chemistry of Respiration. By M. S. P.,	180
XLVII. Determination of the Respiratory Exchange in Man. By M. S. P.,	184
XLVIII. Respiration Apparatus. By L. H.,	186
XLIX. The Chemistry of Respiration. The Gases of the Blood. By L. H.,	187
L. The Oxygen Capacity of Blood. By M. S. P.,	190
LI. The Effects of Changes in Atmospheric Pressure. By L. H., -	192
LII. The Influence of Carbon Monoxide. By M. S. P., -	194
LIII. The Regulation of Respiration. By M. S. P.,	195
LIV. Cheyne-Stokes Respiration. By M. S. P.,	197
LV. The Influence of the Vagus upon Respiration. By M. S. P.,	199
LVI. Animal Heat. By M. S. P.,	200
LVII. Investigation of the Motor Functions of the Alimentary Canal by means of the X-Rays. By A. F. Hertz,	203
LVIII. Salivary Secretion. By L. H.,	210
LIX. The Functions of the Central Nervous System. By M. S. P.,	214
LX. Reaction Time. By M. S. P.,	216
LXI. The Rate of Discharge of Nervous Impulses from the Central Nervous System. By M. S. P.,	217

CHAP.	PAGE
LXII. The Functions of the Anterior and Posterior Roots of the Spinal Cord. The Bell-Majendie Law. By M. S. P.,	220
LXIII. Müller's Law of the Specific Energy of Nerves. By M. S. P.,	222
LXIV. Cutaneous Sensations. Sensations derived from Movements (<i>Advanced</i>). By J. S. E.,	223
LXV. The Dissection of the Eye. By J. S. E.,	226
LXVI. The Eye as an Optical Instrument (<i>Advanced</i>). By J. S. E., - - -	228
LXVII. The Refracting Media of the Eye. By J. S. E.,	232
LXVIII. The Retina. By J. S. E.,	240
LXIX. Sensations of Light and Colour. By J. S. E.,	245
LXX. Binocular Vision. By J. S. E.,	254
LXXI. The Optical Defects of the Eye. By J. S. E.,	258
LXXII. The Optical Defects of the Eye (<i>Advanced</i>). By J. S. E.,	261
LXXIII. The Instruments used in the Clinical Investigation of the Eye. By J. S. E., -	263
LXXIV. Dissection of the Ear in the Skate. Auditory Sensations. By J. S. E., -	267

PART II.

PHYSIOLOGICAL CHEMISTRY.

By J. J. R. MACLEOD and M. FLACK.

Introduction,	270
I. Carbohydrates. By J. J. R. M.,	272
II. Carbohydrates (<i>continued</i>). By J. J. R. M., -	279
III. Carbohydrates (<i>continued</i>). By J. J. R. M., -	288
IV. Proteins. By M. F.,	297
V. Proteins (<i>continued</i>). By M. F.,	304
VI. Fats, Fatty Acids, Phosphorised Fats and Cholesterol. By J. J. R. M.,	313
VII. Milk. By M. F., -	324
VIII. Blood. By M. F.,	331
IX. The Spectroscopic Examination of Haemoglobin and its Derivatives. By J. S. Edkins,	342

CHAP.	PAGE
X. Muscle. By M. F.,	350
XI. Dietetics, Food, Metabolism. By M. F.,	359
XII. Digestion in the Mouth. By J. J. R. M.,	371
XIII. Digestion in the Stomach. By J. J. R. M.,	375
XIV. Digestion in the Intestine. By J. J. R. M., -	387
XV. Bile. Bacterial Digestion. By J. J. R. M.,	397
XVI. The Chemistry of Urine. By J. J. R. M.,	407
XVII. Urea. By J. J. R. M., -	415
XVIII. Uric Acid and other Purine Bodies. By J. J. R. M.,	422
XIX. The Inorganic Acid Radicles of Urine. Urinary Deposits. By J. J. R. M., -	434
XX. Pathological Urine. By J. J. R. M.,	442
XXI. Lactic Acid, its Estimation and Significance. By J. H. Ryffel,	454
XXII. Haemolysis and Precipitins. By J. J. R. M.,	460
XXIII. The Pigments of Urine. By J. S. Edkins,	467
 Appendix--Analytical Tables. By J. J. R. M.,	 469
Index—Part I., Experimental Physiology,	474
Index—Part II., Physiological Chemistry,	478

WEIGHTS AND MEASURES.

LENGTH.

Metric or Decimal.		English.
1 Metre (M.)	-	= 39·3701 inches.
1 Decimetre (dm.)	. . .	= 3·9370 „
1 Centimetre (cm.)	-	= 0·3937 „
1 Millimetre (mm.)	-	= 0·0393 „
1 Micromillimetre (mkm)	-	= 0·000039 „

The unit of the Metric System is the Metre, which represents one ten-millionth part of a quarter of the meridian of the earth. The multiples and subdivisions are obtained by the use of decimals; the former being designated by Greek prefixes, the latter by Latin prefixes.

1 Myriametre (Mm.)		= 6·2137 miles.
1 Kilometre (Km.)	-	= 0·6214 „
1 Hectometre (Hm.)		= 109·361 yards.
1 Dekametre (Dm.)	-	= 32·8084 feet.
1 Metre (M.)	. . .	= 39·3701 inches.

WEIGHT.

Metric or Decimal.		English.
1 Kilogramme (Kgm.)	. . .	= 2·2046 pounds.
1 Gramme (Gm.)	-	= 15·4323 grains.
1 Decigramme (dgm.)	-	= 1·5432 „
1 Centigramme (cgm.)	-	= 0·1543 „
1 Milligramme (mgm.)	-	= 0·0154 „

The unit is the Gramme which represents the weight of a cubic centimetre of water at 4° C.

APOTHECARIES WEIGHT.

437·5 grains (gr.)	= 1 ounce.
16 ounces (℥)	= 1 pound (lb.).
* { 60 grains	= 1 drachm (ʒ).
* { 20 grains	= 1 scruple (ʒ).
1 grain	= 0·0648 gramme.

* Not official.

AVOIRDUPOIS WEIGHT.

16 drachms	= 1 ounce (oz.).
16 oz.	= 1 pound (lb.).
28 lbs.	= 1 quarter (qr.).
4 quarters	= 1 hundredweight (cwt.).
20 cwt.	= 1 ton.
1 pound	= 453·592 grammes.
1 ounce	= 28·35 grammes.

WEIGHTS AND MEASURES

CAPACITY.

Metric or Decimal.		English.
1 Dekalitre (Dl.)	- .	= 2.1998 Imperial gallons.
1 Litre (L.)	- .	= 35.196 Imperial fluid ounces.
1 Decilitre (dl.)	- .	= 3.5196 „ „
1 Cubic centimetre (c.c.)	} -	= 0.0352 „ „
or		
1 Millilitre (ml.)		
<hr/>		
60 minims (m)	- . .	= 1 fluid drachm (ʒ).
8 fluid drachms	- . .	= 1 fluid ounce (ʒ).
20 fluid ounces	- . .	= 1 pint (O).
8 pints	- . .	= 1 gallon (G).
<hr/>		
1 cubic centimetre	- . .	= 16.9 minims.
1 fluid ounce	- . .	= 28.42 cubic centimetres.
1 pint	- . .	= 568.34 cubic centimetres.
1 gallon	- . .	= 4.54 litres.

THERMOMETERS.

FAHRENHEIT AND CENTIGRADE SCALES.

To convert degrees F. into degrees C., deduct 32, multiply by 5, and divide by 9.

To convert degrees C. into degrees F., multiply by 9, divide by 5, and add 32.

F.	C.	F.	C.
212°	100°	80°	26.7
112	44.4	70	21.1
106	41.1	60	15.6
104	40.0	50	10.0
102	38.9	41	5.0
101	38.3	32	0.0
100	37.8	23	- 5.0
99	37.2	14	- 10.0
98	36.7	5	- 15.0
97	36.1		

AVERAGE WEIGHTS AND HEIGHTS.

Average weight of a healthy male child at birth - . . = 6.8 lbs.

„ „ „ six months' old - = 12.4 „

„ „ „ twelve „ - = 18.8 „

An adult man (dressed) 5 feet 8 inches in height, should weigh 11 st. 1 lb. and should have a chest circumference of 38½ inches.

PART I.

MUSCLE AND NERVE. CIRCULATION. RESPIRATION. ANIMAL HEAT. CENTRAL NERVOUS SYSTEM AND SPECIAL SENSES.

THE PHYSIOLOGY OF MUSCLE AND NERVE.

Introduction.—Physiology, the study of the properties of living organisms, can be properly appreciated and learned only when it is approached from the practical and experimental side. The study of the simplest forms of life, the unicellular organisms, is as yet only in its infancy, and at the present moment experimental physiology deals almost entirely with the functions of the various tissues and organs which together make up a vertebrate animal.

The cold-blooded vertebrate, the frog, is the most suitable animal for elementary experiments upon muscle and nerve; it is readily obtained, and its tissues under suitable conditions retain their vitality for many hours after they have been excised and cut off from their supply of blood.

The muscular, nervous, and vascular systems of the frog are the most important in an experimental course of physiology, for although muscle and nerve are highly differentiated forms of protoplasm with correspondingly characteristic functions, yet they show only in an exaggerated way properties which are common to all living matter. Thus in muscle the power of contraction or movement is highly developed; in nerve the property of excitability or irritability, the response to a stimulus.

CHAPTER I.

ELECTRICAL APPARATUS FOR PHYSIOLOGICAL EXPERIMENTS.

IN experimental physiology the stimulus most frequently used is an electrical one, for it is convenient, easily graduated, and less injurious to tissues than efficient thermal, chemical, or mechanical stimuli would be.

The **Daniell Cell**, which has an electromotive force (E.M.F.) of 1.1 volts, is the best source of electricity, for it yields an almost constant strength of current. It consists (Fig. 1) of (i) a plate of copper dipping

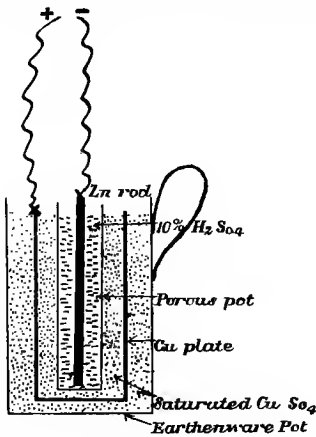

FIG. 1.—Diagram of a Daniell cell seen in section.

into a solution of copper sulphate which is kept saturated by crystals of the salt, and (ii) a rod of amalgamated zinc placed in a porous pot filled with a 10 per cent. solution of sulphuric acid; the porous pot is surrounded by the solution of copper sulphate. The whole is generally placed for convenience in a glazed earthenware pot with a handle.

When the copper and zinc elements are connected by a wire the zinc dissolves in the sulphuric acid, forming $ZnSO_4 + H_2$. The H ions thus liberated become charged with the electricity originally stored

in the zinc; they migrate through the porous cell into the copper sulphate and split it up into $H_2SO_4 + Cu$, and their charge of electricity is transferred to the Cu ions. These in turn deliver up their charge of electricity to the copper plate and, as they discharge, become deposited on the plate as metallic copper.

Thus inside the cell electricity passes from the zinc, or positive

element, to the copper or negative element; outside the cell the current passes from the copper binding-screw, the positive pole or anode of the battery, to the zinc binding-screw, the negative pole or kathode.

If plates of copper and zinc were simply immersed in 10 per cent. sulphuric acid, the chemical action set up would soon cause the copper plate to be covered with bubbles of hydrogen gas. This would cause a resistance to the flow of current inside the cell, and further, hydrogen being electro-positive to zinc, a polarisation current in the opposite direction to the original battery current would be set up in the cell and rapidly reduce its E.M.F. Daniell, by placing the copper plate in a solution of copper sulphate, which the hydrogen splits up, prevented polarisation from taking place within the battery.¹ Therefore as long as there is free sulphuric acid present and the copper sulphate is saturated, the current produced by the cell remains constant. Provided too that the porous pot, which is to prevent the deposition of copper on the zinc rod, remains permeable to the H ions.

The zinc rod has to be amalgamated because commercial zinc contains iron and other metallic impurities; these in the presence of the sulphuric acid would, with the zinc, constitute a number of minute batteries. By covering the impurities with zinc amalgam their disturbing action is removed, and as the zinc is dissolved away, the mercury combines with fresh zinc so that the electromotive properties of the zinc rod remain constant.

¹ A more accurate description of the chemistry of a Daniell cell is as follows: The cell consists of two metals, zinc and copper, dipping into an electrolyte containing various ions in solution; these are H, SO_4 , OH, Cu and SO_4 , of which Cu and H, being positive ions, will work their way towards the negative element, the copper plate and the OH and SO_4 being negative ions towards the zinc. When in use chemical changes take place around both metallic plates. The zinc is attacked by the SO_4 ions discharging, forming ZnSO_4 , and energy is liberated, which is conducted across the electrolyte by the ions in solution. Around the copper plate the copper sulphate is being split up into SO_4 and Cu ions, in which process energy is stored up. But the energy liberated at the zinc plate is greater than that stored in the neighbourhood of the copper plate, therefore the cell, when working, is always liberating a balance of energy which appears as an electric current. The SO_4 ions, constantly being liberated in the copper sulphate solution and charged with electricity, migrate through the porous pot towards the zinc, discharge forming ZnSO_4 and a liberation of energy as explained. Towards the copper plate both H and Cu ions charged with electricity are constantly streaming. That it is the Cu ions and not the H ions which discharge and become precipitated on the plate depends simply upon the fact that it requires a less energy and a lower E.M.F. to separate Cu than H ions. Therefore as long as there are sufficient Cu ions present to conduct the current, Cu ions and not H ions will discharge and be precipitated on the copper plate.

Keys are instruments for making or breaking electrical circuits and for short-circuiting currents.

The **Mercury Key** consists of a small cup hollowed out of a piece of vulcanite (Fig. 2). From the cup, which is nearly filled with clean mercury, pass in opposite directions two stout copper wires with

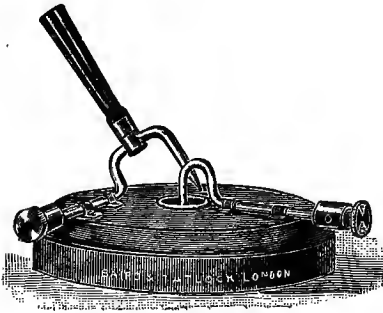

FIG. 2.—The mercury key.

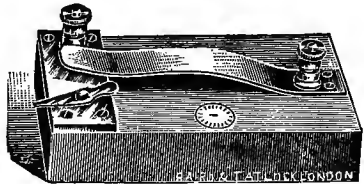

FIG. 3.—The spring key.

binding-screws; one wire and binding-screw are fixed to the vulcanite base, the other wire can be raised out of or lowered into the mercury by an insulated handle. In some forms of mercury key the wires connecting the binding-screws to the mercury cup run through the vulcanite; the ends of these wires are liable to become oxidised and dirty, and in consequence they make bad contact with the mercury. In order to avoid this it is only necessary to fix the insulated wires from the battery to the binding-screws and to turn the naked ends of these wires over into the mercury.

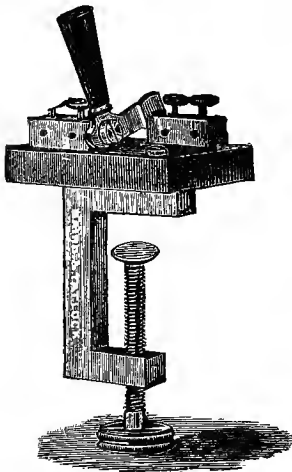

FIG. 4.—The Du Bois key.

The **Spring Key** is made of a block of lacquered wood, to one end of which is attached a broad brass spring with a binding-screw, and to the other end a plate of brass with a binding-screw (Fig. 3). When the spring is depressed by the finger its free end touches the brass plate and connects together the two binding-screws. The brass plate carries a clip which can clamp the spring in contact with the plate.

The **Du Bois Key** consists of two metal blocks each carrying two binding-screws and attached to a vulcanite base (Fig. 4). The

metal blocks can be connected by a thick brass bar attached to an insulated movable handle. This key, like the mercury and spring key, may be used as a simple make and break key (Fig. 5); but its

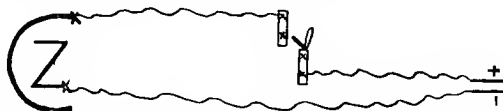

FIG. 5.—Plan of the use of a Du Bois key, as a simple make and break key.

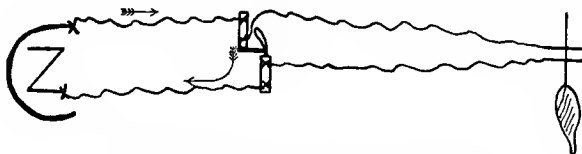

FIG. 6.—Arranged as a short-circuiting key: key shut.

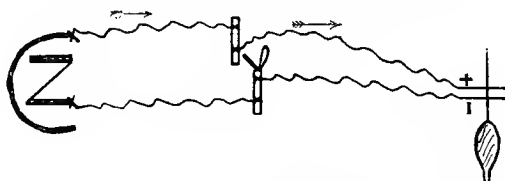

FIG. 7.—Arranged as a short-circuiting key: key open.

proper use is as a short-circuiting key (Figs. 6 and 7); and when a Du Bois key is directed to be used, it must be inserted into the circuit as a short-circuiting and not as a simple key.

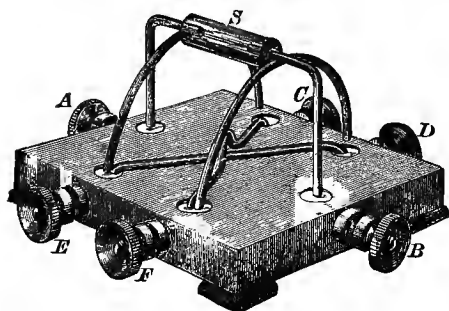

FIG. 8A.—The Pohl's reverser. *A* and *B* the two side cups; *C*, *D*, *E* and *F* the four corner cups; *S* the handle made of glass or vulcanite.

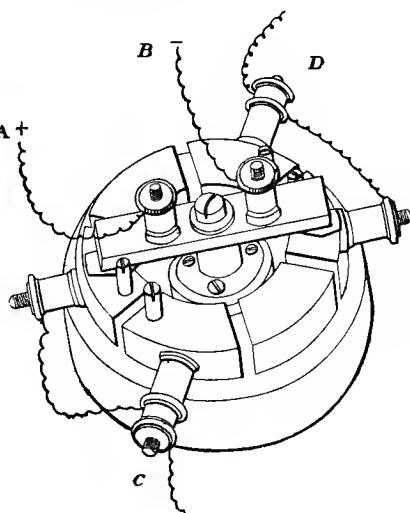

FIG. 8B.—Universal key (Gotch). The key is used by rotating the arm containing the screws connected with the wires *A* and *B*, which come from the battery. In the position shown the current flows from the wire of *C* to that of *D*; if rotated through 45° there is a complete double break of the battery-circuit; if rotated through 90° then the current is remade and the current flows from the wire of *D* to that of *C*.

The Pohl's Reverser consists of six mercury cups hollowed out in a block of vulcanite, each cup being connected to a binding-screw (Fig. 8A). The four corner cups are connected diagonally by stout copper wires which do not touch each other. The two side cups are

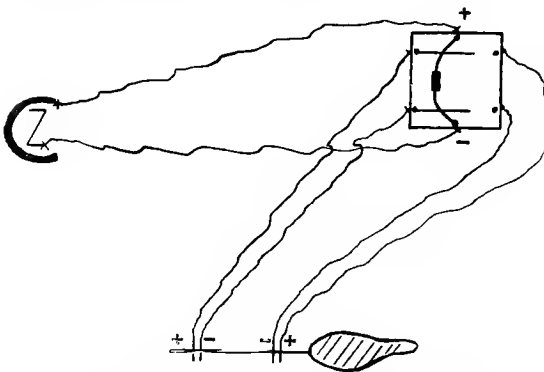

FIG. 9.—Plan of the arrangement of the two alternative circuits.

joined by stout copper wires to a non-conducting cross-piece, which acts as a handle. Each end of the handle also carries a semicircle of copper wire which is connected to the wire going into the side cup, and is of such a length that it will dip

into the cup at either end by turning the handle over towards that end. If the handle is in such a position that a current, entering the reverser by one of the side cups, emerges by an end cup of the same side, then, by turning the handle over, the cross-wires come into use, and the current will now emerge by the end cup of the opposite side.

The instrument may also be used to send a current into either of two circuits. The cross-wires are removed, the wires from the battery are connected to the two side binding-screws, and to each pair of end cups the wires of the two alternative circuits (Fig. 9). Then by turning the handle over the current may be sent into either of these two circuits.

A much more efficient instrument is the universal key (Fig. 8B), which has recently been introduced by Gotch. It can be used as a double break-key, a reverser and a shunt.

The term **Electrodes** is applied to the free ends of the two wires which conduct the current to the tissue to be stimulated. They consist

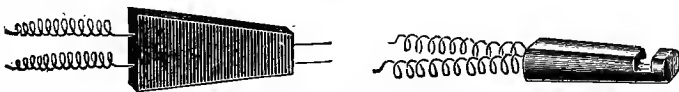

FIGS. 10 AND 11.—Two forms of electrodes.

of two insulated wires, the ends of which are clean and free from insulating material, carried in some form of holder; this is generally made by running the wires through a piece of vulcanite, cork, or model-

ling wax (Figs. 10 and 11). A form of electrode sometimes very useful is made by soldering the free end of each wire to the head of a needle.

The **Rheochord** is used to alter the strength of a constant current to be sent through a muscle or nerve. In its simplest form it consists of



FIG. 12.—Simple form of monochoord.

a single straight or zig-zagged wire with a binding-screw at either end and a movable contact between them (Fig. 12). If a Daniell cell be

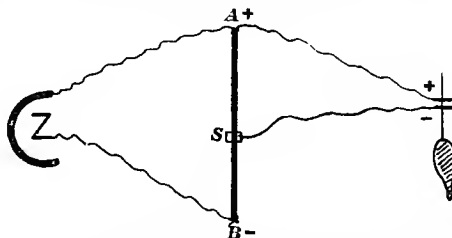

FIG. 13.—To illustrate the principle of the monochoord.

connected to the two ends of the monochoord A and B (Fig. 13), there will be a fall of potential in it from A to B. If from A and the

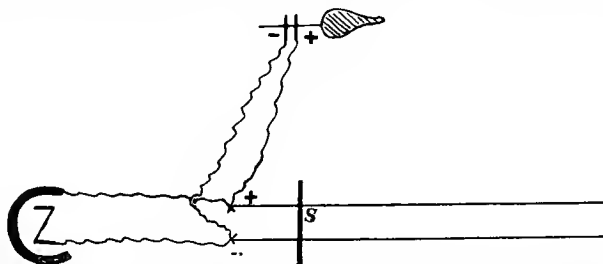

FIG. 14.—The rheochord arranged to vary the strength of a current passing through a nerve. It consists of two parallel wires connected by a movable metal slider S. By moving the slider S to the right the resistance of the rheochord in circuit and therefore the amount of battery current passing through the nerve would be increased.

movable contact S two electrodes pass to a nerve, the current from the battery has two circuits open to it and can pass either through the nerve or along the monochoord back to the battery. The

amount of current which will pass through the nerve will be directly proportional to the difference in potential between A and S, *i.e.* if the fall in potential in the monochord is uniform, proportional to the distance between A and S, being greater as S is moved away from A; it is also inversely proportional to the resistance of the circuit through the nerve. But the resistance of this circuit may be considered constant for all positions of S, since the resistance in the nerve itself is enormously greater than that caused by any change in the length of the monochord wire in the circuit.

Although the Daniell cell is the most convenient source of current, and its strength can be regulated by a rheochord, and although the

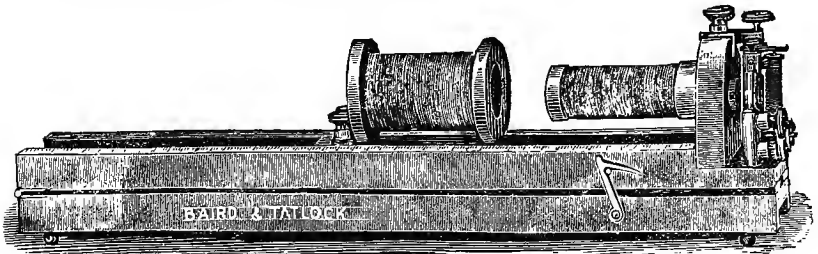

FIG. 15.—The induction-coil.

make and break of a constant current do act as a stimulus to muscle and nerve, it is often more convenient to use induced currents. These are obtained by connecting a Daniell cell to an induction coil, and their advantages are: (1) That being of extremely brief duration as compared with the make of a constant current, they set up practically no polarisation in the tissues (see page 78). (2) Having a comparatively large E.M.F. and rapid development, as compared with the galvanic current, they constitute a much more effective stimulus. For, the law of excitation states that the effectiveness of a current as a stimulus depends not only upon the total variation in its intensity, but also upon the amount of such variation in the unit of time, *i.e.* the greater the rapidity of the total variation, the more effective is the current as a stimulus.

The Induction-coil (Fig. 15) consists of two coils, of which the primary is made up of a few turns of insulated thick copper wire with only a small resistance. This is wound round a core of iron wire to increase the number of lines of magnetic induction which pass through it. The ends of the wire forming the primary coil are connected with the top binding-screws 1 and 2 (Fig. 16).

The secondary coil is made up of a large number of turns of insulated

fine copper wire. The large number of turns of wire in the secondary as compared with the primary coil, transforms the low E.M.F. of the current in the primary circuit into a high E.M.F. in the secondary circuit; for each turn in the primary coil induces an effect in every turn of the secondary coil, so that the sum of all these effects is a single one of greatly increased intensity.

The long fine wire of the secondary coil gives it a great resistance, but when the induced currents are passed through the relatively enormous resistances of animal tissues this is unimportant.¹

The ends of the wire of the secondary coil are connected to the binding-screws 3 and 4 (Fig. 16).

The E.M.F. of the induced current varies with the following factors: (1) It varies directly with the intensity of the change of current in the primary circuit, so that if no current or a current of constant strength be running through the primary coil no induction occurs; but if the strength of the current in the primary circuit does change, whether it be an increase or decrease, the greater the change the stronger will be the induction. (2) It varies directly as the rate of change in the

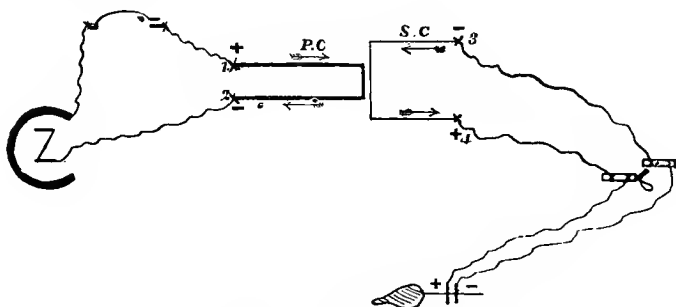

FIG. 16.—Diagram of an induction-coil and its connections.

strength of the inducing current, so that, if the constant current be increased or decreased greatly in strength, but sufficiently gradually, no induction takes place; on the other hand, for a given change in the constant current the more rapid the change the greater the induction. (3) It varies with the angle between the primary and secondary coils in such a way that when the two coils are accurately at right angles there is no induced current; but the strength of the induction increases as the angle between the coils is altered until the maximum is reached, when the wires are parallel to each other. If the secondary coil be

¹The resistance of a piece of a frog's sciatic nerve 1 cm. long is about 100,000 ohms.

movable horizontally on a central point, the strength of the induced current can be graduated by altering the angle between the two coils. (4) It varies inversely as the distance between the two coils, being greatest when the secondary is completely over the primary coil, and becomes less and less as the coils are separated. The strength of the induced current is usually regulated by varying the linear distance between the coils, and most induction-coils are graduated by a millimetre scale fastened to the side of the carrier, so that the pointer in the secondary coil is at the zero of the scale when the one coil is exactly covered by the other. This graduation, however, is purely arbitrary, for the absolute decrease in the strength of the induced current becomes less and less for every centimetre that the coils are separated. An exact graduation can be obtained by a scale corresponding to equal galvanometric deflections.

The direction of the induced current in the secondary coil is, at make of the battery-circuit, in the opposite direction, and at break of the battery-circuit, in the same direction as the battery-circuit in the primary coil. Most coils are so wound that when at make the battery current enters the primary coil by one top binding-screw, the induced current leaves the secondary coil by the binding-screw of the opposite side (Fig. 16).

The Use of Make- and Break-Induction Shocks as Stimuli.—Two wires are connected with the poles of a Daniell cell; the free end of one wire is fastened to one binding-screw of a spring-key, and to the other screw of the key is fixed a third wire. The clean free ends of the wires are placed on the tongue, and the key is opened and closed; no shock is produced, but only a sensation of taste; the intensity of the current is insufficient to produce a marked excitation.

The free ends of the wires are now connected with the screws, or terminals, 1 and 2 of the induction-coil and a Du Bois key is placed in the secondary circuit (Fig. 16). The secondary coil is pushed far apart from the primary, and the Du Bois key is opened; make and break of the primary circuit produces no excitation, for the induction-currents are too weak. The secondary coil is gradually moved towards the primary, and the spring-key is opened and closed from time to time, until a point is reached at which a shock is felt at break, but not at make of the constant current. The position of the secondary coil on the scale is noted. As the secondary coil is moved up further, the break-shock becomes greater, and a slight shock is also felt at make; in a similar way the two shocks can be further increased, but *the break-shock remains greater than the make-shock.*

It is especially to be noted that there is no induction-shock if the

primary circuit remains closed by the spring-key. *An induction shock is produced only at the make or the break of the constant current.*

Closure of the Du Bois key short-circuits the electrodes, and no shock will be felt on make or break of the constant current. By means of this key the make- or break-induction shock, or both, can be shut off from the electrodes.

The secondary coil is now removed from the grooves of the carrier, and is placed close to, but at right angles to, the primary coil: no shock is produced when the primary circuit is closed or broken. The secondary coil is gradually turned on its vertical axis, and the spring-key is opened and closed from time to time. A shock will be felt first at break, then at make, and these will increase until the maxima are reached when the secondary coil is parallel to the primary.

These simple experiments show that the make and break of a galvanic current can act as weak stimuli; that on connecting the Daniell cell with the induction-coil induced currents are produced in the secondary coil only at make and break of the battery-current and not when it is running with constant strength through the primary coil; that the induced currents are very effective stimuli, can be easily graduated in strength and short-circuited by a key. It has further been shown that the break induction-shock is stronger than the make. The cause of this difference lies in the primary coil, and needs explanation.

When the battery-current enters the primary coil, it induces a current in it as well as in the secondary coil. This "self-induced" or make extra current, like that induced in the secondary coil, is a momentary current in the opposite direction to the battery-current; hence it delays the rapidity with which the battery-current reaches its maximal intensity in the primary coil and weakens the effect which change in current in the primary coil will induce in the secondary coil. On the other hand, when the battery-current is broken, the current in the primary coil suddenly runs down to nothing; and although a break extra current, running momentarily in the same direction as the battery-current, is induced in the primary coil, it cannot delay the rapidity of the fall of the battery-current, because a primary circuit no longer exists in which the extra current could run.

Demonstration of the Break Extra Current.—Connect a cell with binding-screws 1 and 2 of the induction-coil, placing a spring-key in the circuit. Fasten to the same binding-screws of the primary coil two wires, the free ends of which are placed on the tongue. On closing the spring-key no shock is felt, but, on opening it, the shock of the break extra current.

A purely physical proof of the break extra current can be obtained by connecting one pole of a battery to the primary coil, and by touching with the other wire from the battery the milled head of the other binding-screw of the primary coil. Every time that the battery circuit is broken, the break extra current will pass across from the screw to the wire as a minute spark; no spark, or a very feeble one, is seen on touching the first terminal, for in this case there is no current in the primary coil.

Equalisation of Make and Break Induced Currents.—From what has been said it is clear that, if the break extra current were provided with a circuit to run in, the strength of the current induced in the secondary coil at break would be reduced to that of the current induced at make; and so they would be equalised. In order to effect this the battery-circuit is not broken, but is nearly completely short-circuited out of the primary coil by a Du Bois key (Fig. 17). Now again test the relative strengths of the make and break induced currents.

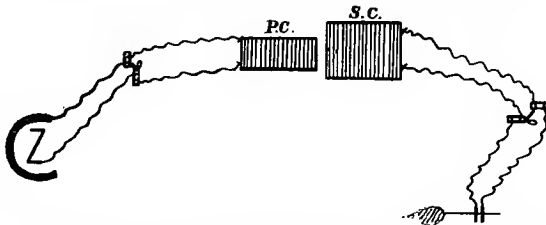

FIG. 17.—Arrangement of apparatus for equalising the make and break induced currents.

They may be approximately equal, but the original difference is not infrequently overcorrected, and now the break-shock is the weaker. This is caused by the make and break extra currents running in circuits of different resistance. At make the extra current runs not only through the primary coil but also through the resistance of the Daniell cell; but at break the extra current has to run only through the resistance of the primary coil, hence it is the more effective current of the two, and reduces the effect induced in the secondary coil at break more than the make extra current does on closing the primary circuit.

Faradic or Tetanising Shocks.—Induction-coils are provided with an automatic arrangement for rapidly making and breaking the primary circuit by means of Wagner's hammer. Connect up the battery to screws 5 and 6 of the coil, interposing a spring-key, and follow out the primary circuit (Fig. 18). The current passes up the pillar A along the spring H to the screw S_1 , through the primary

coil to the electro-magnet E, and so to the pillar B. When the circuit is thus made, E becomes an electro-magnet, pulls down the spring H from its contact with S_1 and breaks the circuit; consequently E ceases to be a magnet, the spring flies up into contact with S_1 , and again

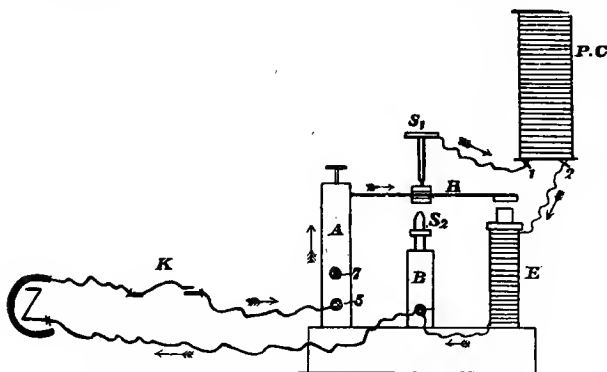

FIG. 18.—Diagram to show the action of Wagner's hammer.

completes the circuit. The number of times the circuit will be thus made and broken per second depends upon the length of the spring H; in most coils it is of such a length as to give 50 complete vibrations per second. At each make and break of the circuit a current is induced in the secondary coil, just as when the circuit was broken by hand;

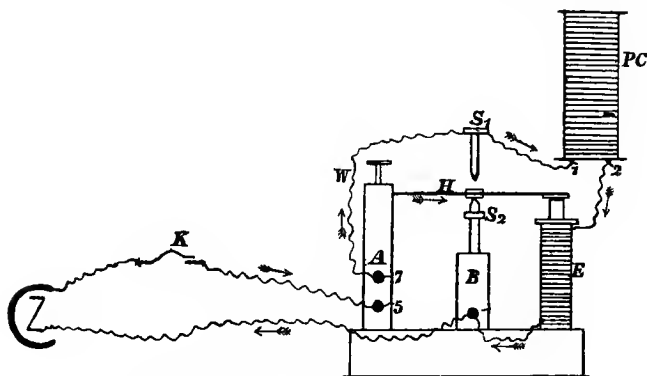

FIG. 19.—Diagram to show the action of the Helmholtz side-wire.

further, the break-shock is stronger than the make-shock, and for the same reason as before.

Determine the distance necessary between the two coils for the shocks just to be felt on the tongue.

Helmholtz showed that it is possible to equalise these Faradic shocks by short-circuiting, instead of completely breaking, the battery-current, and for the reason already explained. For this purpose (Fig. 19) a stout wire, W, connects the binding-screws 7 and 1, S_1 is screwed up out of reach of the spring, and S_2 is screwed up. Follow the circuit of the current which passes from binding-screws 7 to 1 by the side-wire, and so to the primary coil, back to the electro-magnet E, to binding-screw 6 and to the battery. When, however, the current reaches E, it becomes a magnet, and pulls down the spring into contact with S_2 . This short-circuits the battery-current out of the coil, for the current will now pass from the pillar A, by way of H, to the pillar B, and so back to the battery. There is still left the circuit 7 W, 1, PC, E, H, A, 7, in which the break extra current can run and reduce the strength of the current induced in the secondary coil at break.

Determine the distance between the coils at which the shocks are now just felt on the tongue; it will be found to be reduced, showing that the break-shock which was alone felt before has been reduced down to or even below the strength of the make-shock.

CHAPTER II.

THE GRAPHIC METHOD. MAXIMAL AND MINIMAL STIMULI. UNIPOLAR EXCITATION.

THE graphic method is applied to muscle in order to obtain a permanent magnified record of the change in form of a muscle during contraction, and further, to investigate the time-relations of the contraction. For this purpose it is necessary to describe the method of preparing the muscle and then three special pieces of apparatus: (1) a magnifying lever, the muscle lever, or myograph, which can write on (2) a surface either stationary or moving at a uniform rate, the drum, and (3) an instrument for recording time on the drum, the chronograph, which will be described in Chapter III.

The Muscle- and Nerve-Preparation.—The quickest way to kill a frog is to “pith” it. The articulation between the skull and the vertebral column can be felt with the tip of the finger; it is severed by a transverse cut with a pair of scissors, and then a probe or blanket-pin is inserted into the skull to destroy the brain. The spinal cord is destroyed in a similar way, and this final stimulation of the nerve-cells

causes a discharge of motor impulses to the muscles of the body, which give a series of convulsive twitches or contractions. These twitches quickly cease, the body and limbs are in a toneless, relaxed condition, and all reflexes have been abolished.

The frog is then placed belly downwards on a frog-board, and the skin at the ankle is divided by a circular incision; the tendo-Achillis is exposed and a thread passed under the tendon and tied just above the sesamoid bone. In this way a ligature is attached to the muscle with-

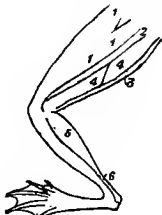

FIG. 20.

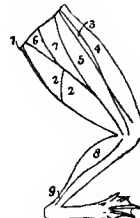

FIG. 21.

Muscles of the frog's leg. (After Ecker.)

FIG. 20.—Dorsal aspect.

1. Triceps femoris.
2. Biceps femoris.
3. Rectus internus.
4. Semi-membranosus.
5. Gastrocnemius.
6. Tendo Achillis.

FIG. 21.—Ventral aspect.

1. Rectus internus.
2. Gracilis.
3. Adductor longus.
4. Vastus internus.
5. Sartorius.
6. Adductor brevis.
7. Adductor magnus.
8. Gastrocnemius.
9. Tendo Achillis.

out damage to or irritation of its fibres. The tendon is divided below the sesamoid bone, and a pull upwards towards the knee frees the gastrocnemius muscle and the skin from the remaining structures of the leg, which are cut away just below the knee. The gastrocnemius muscle is protected from drying and from contact with foreign substances by drawing down the "trouser" of skin. The sciatic nerve is now dissected in the following way. The skin over the posterior surface of the thigh is divided by a longitudinal incision in the middle line, the biceps and semi-membranosus muscles are separated, and the sciatic nerve is exposed. The nerve must not be pinched with forceps, for it is easily damaged. The muscles on each side of the urostyle and then the urostyle itself are cut away; the three constituent ends of the sciatic nerve are now exposed. The spinal column is divided transversely between the 6th and 7th vertebrae and the 9th, 8th, and 7th vertebrae are bisected. The piece of bone, from which the nerve to be prepared issues, can be grasped with the forceps without damage

to the nerve, and the sciatic nerve is freed from the surrounding tissues as far as the knee. The thigh is then severed from the body by a

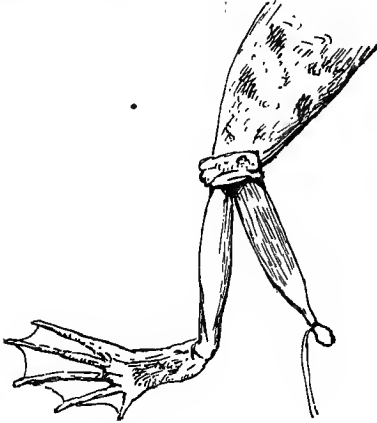

FIG. 22.

Diagrams of a muscle- and nerve-preparation. (Pembrey and Phillips.)

FIG. 22.—The first stage of dissection.

FIG. 23.—The second stage of dissection. The sciatic nerve exposed and the gastrocnemius muscle covered by skin.



FIG. 23.

transverse cut close to the articulation of the head of the femur (Figs. 22 and 23).

In order that the best results may be obtained the muscle- and

nerve-preparation should be as fresh and irritable as possible, and in order to obtain this the following precautions should be observed. (a) All apparatus for the experiment should be in working order before the dissection is commenced. (b) The muscle must be prevented from drying by keeping the "trouser" of skin pulled down over it, and since the nerve is even more easily killed by drying, it should, when not required for immediate stimulation, be allowed to lie among the muscles of the thigh, the lymph of which will keep it

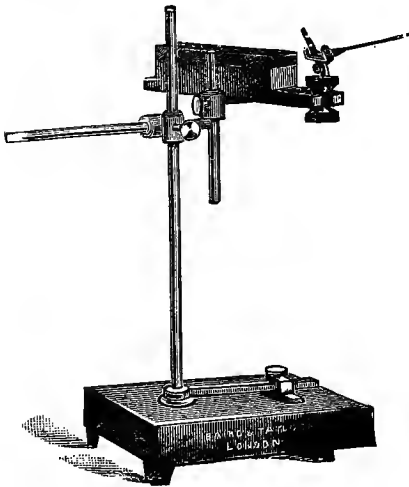

FIG. 24.—The crank-lever, muscle-board and stand.

moist and irritable. The nerve must not be placed upon the frog's

skin, the secretions of which quickly injure it. (c) When the nerve is on the electrodes it must be kept moist by normal tap-water saline solution (.70 per cent. sodium chloride in tap-water) upon a piece of filter-paper, but care must be taken that the current from the electrodes is not short-circuited thereby. (d) The nerve itself should not be picked up by forceps, but should be lifted by the pieces of the vertebral column. Consequently the whole length of the nerve should always be dissected out; as a rule it should not be cut across in the thigh nor simply exposed in the thigh and two electrodes pushed under it.

The Muscle-lever takes one of two chief forms:

(a) The crank-lever (Fig. 24) consists of an L-shaped piece of metal, the horizontal arm of which is long and carries the writing

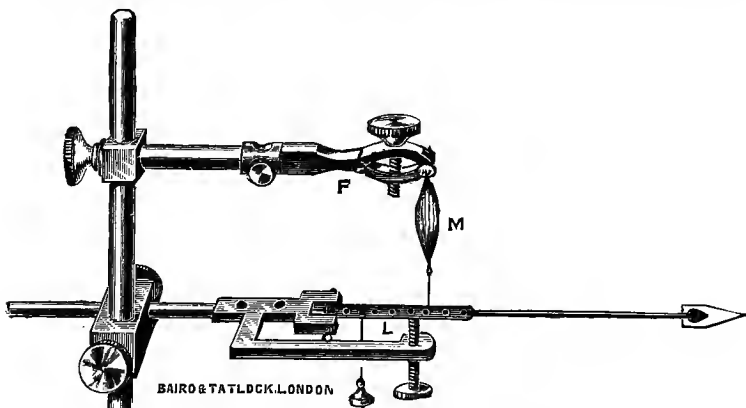

FIG. 25.—The simple lever with after-loading screw. F, clamp; L, lever; M, muscle.

point, whilst the vertical arm is short and to this the thread round the tendo-Achillis is firmly tied. The muscle rests, in the same straight line as the lever, on the muscle-board, a horizontal piece of wood covered with cork. The whole is carried on a vertical stand (Fig. 24), the arm of which is movable on the base, so that the writing point of the myograph can be swung towards and away from the drum without altering the position of the base of the stand. When the thread has been tied to the lever, a pin is pushed through the lower end of the femur into the cork; this gives the muscle a fixed point from which to pull. It is necessary to see that, when the muscle is at rest, the thread attached to the lever is taut, and that there is no "slack" to be taken in when contraction begins; further, the writing arm should be horizontal.

In this form of lever the movement of the writing point is at right

angles to the movement recorded. The magnification of the movement of the muscle recorded by the lever is calculated by dividing the distance of the writing point from the axis by the distance from the axis of the point of attachment of the thread from the tendon. The nearer to the axis the muscle is attached the greater will be the magnification. It is quite sufficient to magnify the movement of the muscle 5 times.

(b) The simple lever (Fig. 25) consists of two parts: a rigid femur-clamp to hold the piece of femur, and a horizontal writing lever below it to which the thread on the tendo-Achillis is tied. Care must be taken that the femur-clamp and lever lie in the same plane, and that the muscle is tied to a point on the lever vertically below the clamp. In this case the movement of the writing point is in the same plane as that of the movement recorded. The magnification, as before, is calculated by dividing the distance of the writing point from the axis by the distance of the point of attachment of the muscle from the axis.

The writing lever must be as light as possible (see page 27, Chap. III.), but it must be sufficiently rigid to prevent vibrations being set up in it. For this purpose writing levers are generally made of light metal, glass, Japanese cane or straw.

The actual writing point is made of thin metal foil or moderately stiff paper bent at its free end slightly over towards the drum. The writing point must lie

as nearly as possible parallel to the recording surface, or, in other words, at right angles to a radius of the drum. Further, the bend near its end is necessary; it acts as a weak spring and keeps the writing point up against the recording surface in different positions of the lever. For the end of the lever describes a curved line, and the more it leaves the horizontal position the greater will be the distance of the end of the straw from the recording surface.

The **Kymograph** or recording drum (Fig. 26) consists essentially of a stout brass cylinder which is made to revolve round a vertical axis by either clockwork or string belting from a motor. It is necessary to have some arrangement by which the speed of revolution can be altered within wide limits; this is obtained by various mechanical devices in different patterns of drum, one of which is shown in Fig. 26.

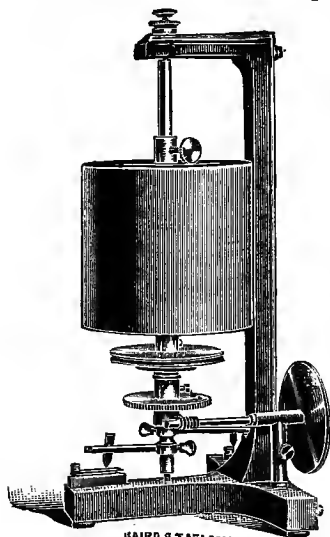

FIG. 26.—Kymograph.

The drum is covered with white glazed paper, the surface of which is then blackened by a thin layer of soot, obtained by revolving the drum through either the luminous part of a broad gas flame or the smoke of burning turpentine or camphor. The writing point of the lever, as the drum revolves, rubs off the layer of soot and leaves a white magnified image of the movement of the muscle or heart or whatever change is being recorded.

The white paper is of the same width and longer than the surface of the drum, and the under-surface of the overlap is gummed. The paper must be laid evenly and without wrinkles round the drum, the gum is then moistened and the paper fastened. The layer of soot obtained from the gas flame should be dark brown in colour, and care must be taken to revolve the drum sufficiently rapidly through the flame to prevent scorching or burning of the paper. The film of soot from camphor is less firmly attached to the paper, and must not be made too thick, otherwise the writing point does not, without undue friction, rub off enough of it to leave a distinct tracing. In recording it must be so arranged that the tracing does not come at the overlap, for the joint in the paper is liable to make the point of the lever jump. Further, it is very important that the drum should be made to revolve away from and not towards the writing point, in other words, the tracing as it is taken should pass from the writing point, not towards but away from the lever. When the tracing is finished, the paper is cut through at the overlap and the details of the experiment written on it. The tracing is preserved by drawing it once through a varnishing solution¹ and pinning it up to dry.

This graphic method, as we shall see, introduces several errors, but such accuracy as it has must depend upon the drum remaining a true cylinder; it is therefore very important that a drum should never be dropped or in any way dented.

Minimal and Maximal Stimuli.—If the strength of the stimulus applied to a muscle be varied within certain limits, it is found that the muscular response also varies, so that the greater the excitation the greater is the shortening of the muscle.

In order to demonstrate this, connect up a Daniell cell to an induction coil so as to give single induction shocks, placing a mercury key in the primary circuit and a Du Bois key in the secondary circuit; cover and smoke a drum. Dissect out a gastrocnemius preparation and attach it to the myograph lever, arrange the electrodes to stimulate the muscle directly; one needle-electrode is used which passes through

¹ A rapidly drying varnish is made by dissolving 250 c.c. of the best white hard varnish in a litre of methylated spirits and then adding 10 c.c. of castor oil.

and fixes the lower end of the femur; the other wire from the Du Bois key is joined to a piece of capillary copper wire which has been threaded by means of a needle through the tendo-Achillis. In this way the current can be passed through the length of the muscle, and the very fine wire will not cause any obstruction to the free movement of the muscle when it contracts. Bring the writing point on to the surface of the stationary drum.

With the secondary coil at 20 cm. and the Du Bois key open, make and break the primary circuit, no contraction will take place. Gradually move up the secondary coil towards the primary, opening and closing the key in the primary circuit at each new position. With the secondary coil at about 16 cm. the muscle will contract at break but not at make, showing that the break induction shock is stronger than the make-shock. The contraction is recorded on the drum by a nearly vertical line, and shows a minimal contraction in response to a minimal stimulus; the make-induction shock is still a sub-minimal stimulus and no contraction results. Rotate the drum on a short distance by hand, move the secondary coil up 1 cm. and stimulate again. Repeat this process, moving the drum on after each contraction and increasing the strength of the stimulus after each make and break of the primary circuit (Fig. 27). As the strength of the stimulus is increased the contraction at break increases in height rapidly at first and then more



FIG. 27.—Heights of contraction of a muscle with different strengths of stimuli. M marks the make and B the break of the primary circuit. The numbers refer to the distances in cms. of the secondary from the primary coil. (A.P.B.)

slowly until, with the secondary coil at about 7 cm., a point is reached beyond which the height does not increase. At 7 cm., therefore, the break-shock and the contraction which it causes are maximal. All stimuli intermediate in strength between minimal and maximal are called sub-maximal. At a certain point the make-shock will be found to become an effective stimulus and cause a minimal contraction. As the make-shock is increased in strength, the contraction rapidly increases in height until, with the secondary coil at about 7 cm.,

it becomes maximal and of about the same height as the break contraction.

The higher the contractions become the more obvious is it that the writing point describes on the stationary drum, not a straight line, but an arc of a circle. The shortening of the muscle, after allowing for the magnification by the lever, is measured not by the length of this arc but by a perpendicular line dropped from its highest point on to the base line.

It is necessary to point out here that, when the primary circuit is made—and the same is true if it be broken—a momentary induced current is both made and broken through the nerve, and yet there is only one contraction of the muscle. It has been found that in a current of such short duration the break stimulus is ineffective because it falls within the refractory period of the make stimulus (see Chap. VII., p. 40). In both cases, whether the primary circuit is made or broken, the effective stimulus to the nerve is only the make stimulus of the induced current.

Unipolar Excitation.—Connect a battery to a coil so as to give tetanising shocks; connect a wire to one pole of the secondary coil and place its free end on the tongue. If the secondary coil be moved completely over the primary, faint shocks will be felt. The explanation of this phenomenon is that the making and breaking of the primary circuit causes free electricity to collect at the end of the wire connected with the secondary coil; when the E.M.F. of this charge is sufficient to overcome the resistance of the tissues of the body, the circuit is completed through the body, the floor and desk, and so back to the other pole of the secondary coil. With the wire still on the tongue, touch the other pole of the secondary coil with a moistened finger; much more powerful shocks are felt because a more direct circuit from one pole to the other of the secondary coil has been provided.

Repeat the experiment on a sciatic-gastrocnemius preparation in the following way, with either tetanising or single-induction shocks. Lay the preparation on a perfectly clean and dry glass-plate and place a wire connected with one pole of the secondary coil under the nerve; no contraction of the muscle takes place because the dry plate insulates the preparation and the secondary circuit cannot be completed. Now touch the muscle with a wire, the other end of which rests on a gas or water pipe; the muscle contracts because the circuit is completed through the earth. It is not even necessary that the conductor should touch the preparation, for, if a moistened finger is brought as near the muscle as possible without touching it, the muscle contracts, especially

if a moistened finger of the other hand touches the other pole of the secondary coil. In this case the human body acts like a condenser charged with electricity, which by its approach can stimulate muscle or nerve. Further, if the nerve be ligatured between the electrode and the muscle, or cut across and the two cut ends laid over each other, which will prevent the passage of a nervous impulse along it, contraction of the muscle is still produced, because the discharge takes place along the whole length of nerve and muscle between the electrode and the point by which the muscle is connected to the earth, so that any irritable tissue in the course taken by the charge is stimulated.

If, however, the muscle and nerve preparation is laid on an ordinary moistened muscle-board, the insulation is so slight that one electrode, connecting the nerve and the secondary coil, will by itself cause the muscle to contract.

It is in order to guard against accidental stimulation of muscle and nerve by unipolar action that a Du Bois key must always be placed in the secondary circuit, and must always be kept closed except when the tissue is being intentionally stimulated. The brass bridge of the key, which has many thousands of times less resistance than the tissue between the electrodes, affords a perfect closure of the secondary circuit and prevents static electrification of the electrodes.

Errors from unipolar action are liable to take place, especially in the study of the electromotive phenomena of muscle and nerve by the electrometer and galvanometer (see Chap. XVIII.).

CHAPTER III.

A SINGLE CONTRACTION OF A GASTROCNEMIUS MUSCLE.

In order to study the contraction given by a muscle in response to a single stimulus, it is not sufficient to inspect the curved line traced by the myograph-lever on a revolving drum. It is also necessary to study the length of time occupied by the whole twitch and the time-relations of different parts of it. For this purpose a time-tracing must be simultaneously recorded by a special apparatus, which generally takes one of two forms.

(1) The **Tuning Fork**; to one prong of this a writing point, similar to that on the myograph-lever, is attached. With the writing point lightly touching the blackened surface of the drum, a sharp tap is given to the fork, and the drum set in motion; care must be taken that the drum does not make more than one revolution, otherwise the time-

tracing will run over itself. The number of complete vibrations per second and the time value of each will depend upon the note of the fork. The most useful fork is one that gives 100 complete vibrations per sec. When more rapid vibrations are required the above method is not suitable, because the vibrations of a fork of a higher note cease so soon after a single tap.

In order to obtain a time-tracing in $\frac{1}{200}$ ths or less of a second, it is necessary to use—

(2) A **Chronograph** or time-marker, which records on a drum the number of times per second a current through it is made and broken by

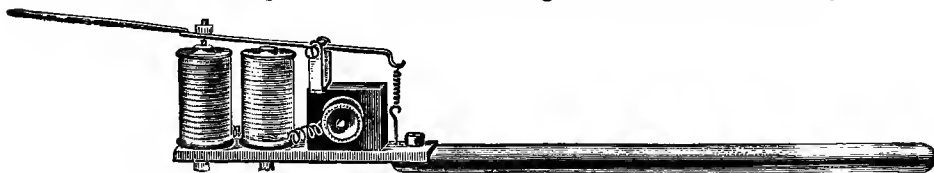

FIG. 28.—A time-marker.

another special piece of apparatus. The chronograph (Fig. 28) consists essentially of an electro-magnet, which, when the current through it is made, attracts and pulls down a metal lever carrying a writing point. When the current through the electro-magnet is broken, a spring at the other end of the lever raises the writing point.

The apparatus used to make and break a current through the chronograph at any definite known rate is a tuning-fork of the corresponding note. To one prong of the fork is attached a platinum wire which,

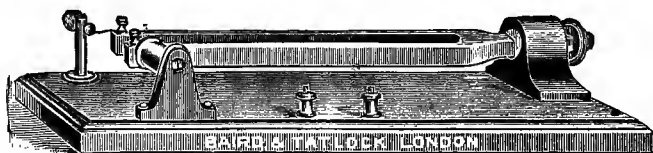

FIG. 29.—A tuning-fork with electro-magnet.

with each complete vibration of the fork, makes and breaks the chronograph circuit by touching and receding from a brass contact or mercury cup (Fig. 29). The tuning-fork, when once started vibrating by a tap, is kept vibrating automatically by an electro-magnet in the same circuit (Fig. 30). Thus, when the platinum wire touches the mercury cup the battery current is made through the chronograph and the writing point is pulled down; at the same time the current is made through the other electro-magnet, which attracts the tuning-fork and pulls the platinum point away from the mercury. Both electro-magnets now cease to act, the writing point of the chronograph is pulled up by the

spring, and the platinum wire of the tuning-fork again touches the mercury, thereby making the circuit again.

To record the contraction of a muscle in response to a single maximal induction-shock, the apparatus is set up in the following way (Fig. 31).

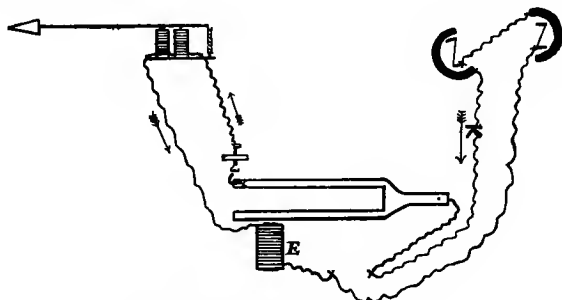

FIG. 30.—Diagram of the chronograph circuit.

Connect one pole of a Daniell cell to one top binding-screw of the primary coil, and the other binding-screw of the coil to a binding-screw on the base of the stand of the drum. The current passes through the metal work of the stand to a metal striker carried beneath the drum on its axle. As the drum revolves this striker touches a strip of naked wire attached to, but insulated from, the rest of the stand. The

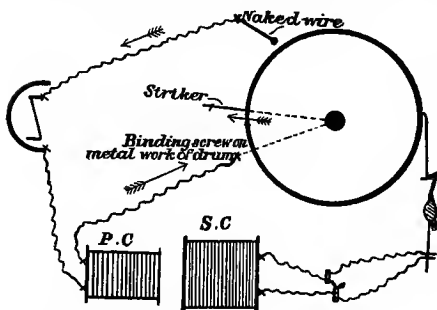

FIG. 31.—Diagram of the apparatus for recording a single muscular contraction.

binding-screw in connection with this naked wire is connected to the other pole of the battery. It is only when the striker and naked wire are in contact that the primary circuit is completed.

A sciatic and gastrocnemius preparation is made and attached to the myograph-lever, which is

weighted near its axis with 10 or 20 grams, and should then be horizontal. The nerve is laid across the electrodes coming from the Du Bois key, and the secondary coil is arranged to give maximal induction-shocks. A tuning-fork giving 100 complete vibrations per second is arranged to write just beneath the myograph lever. Before the two writing points are brought into contact with the smoked surface, the drum should be made to revolve in order to see that it will rotate away from the writing points and at a suffi-

ciently rapid rate; the rate of rotation should not be less than 20 cm. per sec. Adjust the writing points to touch the smoked paper lightly, and with the Du Bois key open, and the fork vibrating, let the drum make one revolution and no more. The curve of the muscular contraction and the time below it in $\frac{1}{100}$ ths of sec. will be recorded (Fig. 32). Close the Du Bois key, remove the tuning-fork, but do not alter the position of the base of the stand carrying the myograph. With the writing point of the lever accurately on the abscissa line of the muscle curve let the drum revolve so as to complete a base line beneath the actual curve corresponding to the muscular contraction. With the writing point still on the base line, rotate the drum by hand until the striker just touches the naked wire. At this position of the

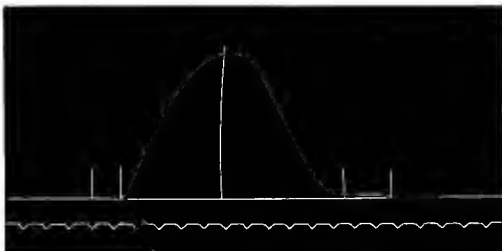

FIG. 32.—Single contraction of gastrocnemius in response to a maximal make shock. Muscle loaded with lever and 30 grms. at axis of lever; actual load on muscle, 6 grms. Magnification, 5. Temp., 15° C. Time marker, 100 per sec. (A.P.B.)

drum a maximal make induction-shock was sent into the nerve; with the finger on the lever make the writing point describe a vertical arc, which cuts the time-tracing below and the abscissa line above. In the same way, by rotating the drum by hand, vertical arcs are drawn through the muscle-curve and time-tracing at the three following points: (1) the point at which the curve leaves the base line, (2) the highest point of the curve, and (3) the point at which the curve regains the base line.

It will be noted that, during the single revolution of the drum, the primary circuit has not only been made but also been broken again by the striker leaving the naked wire. The nerve has consequently received a maximal make and then a maximal break shock, but has only responded by a contraction to the first; for, owing to the rapid rotation of the drum, the second stimulus has reached the muscle too soon after the first for the muscle to be able to respond (see Refractory period of muscle, p. 42). If, however, the drum is revolving but slowly, the second stimulus may follow the first after a sufficient interval of time for the muscle to partly respond to it. This leads

to a deformation of the curve (Fig. 32), in which the hump near the top of the up stroke of the lever is caused by the muscle responding to the second stimulus (see Effect of two successive stimuli, Chap. VII, p. 40). If with a slowly revolving drum it is desired to send into the nerve a single stimulus, it is only necessary to place the secondary coil at such a distance from the primary that the break but not the make shock is effective.

The curve (Fig. 32) occupies about $\frac{1}{100}$ ths sec. and can be divided into three parts.

(1) The first part extends from the point at which the stimulus reached the nerve to that at which the contracting muscle began to raise the lever. This is the latent period, and is seen to last about $\frac{1}{100}$ th of a sec. During this

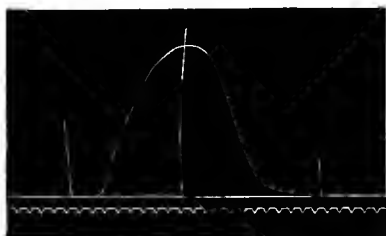

FIG. 33.—Contraction of the same preparation as in Fig. 32, recorded on a drum revolving at a slower rate. The hump near the top of the upstroke of the lever represents a second contraction in response to the break shock. Time marker, 100 per sec. (A.P.B.)

period several distinct processes take place; (a) a nervous impulse has to pass down the strip of nerve between the point stimulated and the muscle, this will occupy about $\frac{1}{1000}$ ths of a second (see Velocity of nervous impulse). Of the remaining $\frac{1}{1000}$ ths (b) the passage of the nervous impulse along the fine motor nerve-endings occupies about $\frac{1}{1000}$ ths sec., and (c) the latent period of the muscle itself about $\frac{1}{1000}$ ths of a sec. This in turn is due to several factors, of which two must be mentioned. When muscle fibres begin to contract a certain time must elapse before the muscle is able to exert a sufficient pull to move the recording lever; in other words, there is instrumental inertia to be overcome. Again, when muscle, which is highly extensible, begins to contract, every part of every fibre does not simultaneously begin to shorten; but the contracted part of a fibre stretches at first the uncontracted part, and is therefore not united to the lever by a rigid connection. It is only when the tension in the stretched part has sufficiently increased, or the fibre as a whole has passed into a state of contraction, that the lever begins to be pulled upon.

(2) The second period extends from the point at which the lever begins to rise to the point highest above the base-line. This is the period of active contraction or shortening of the muscle, and occupies about $\frac{5}{100}$ ths of a sec.

(3) The third portion extends from the highest point of the curve to the point at which the curve rejoins the base-line. This is the period

of relaxation, and lasts about $\frac{6}{1000}$ ths of a sec. Relaxation is a passive process brought about by the falling lever and weight doing the same amount of work on the muscle as the muscle during its period of shortening has done in raising the lever and weight to a certain height.

The muscle-curve, although roughly a magnified record of the change in length of the muscle, is deformed by certain errors of instrumental origin, which it is necessary to mention in order to avoid, so far as they are preventible. The most important are the mass and length of the lever and the disposition of the weight along it. They affect all parts of the curve. The weight of the lever tends to prevent the muscle from beginning to raise it (inertia of position) and so lengthens the latent period; therefore the lever should be as light as possible. During the stage of shortening the lever, when once in motion, tends to be carried on by its own momentum after the muscle has ceased to

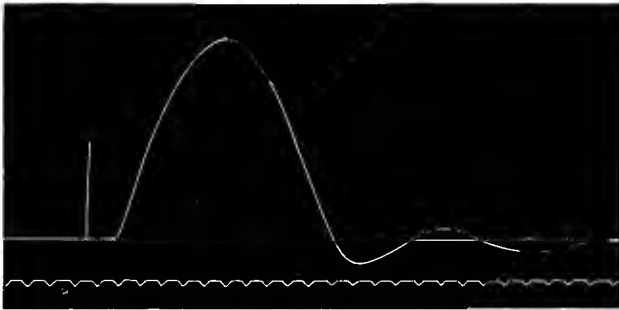

FIG. 34.—Single contraction of gastrocnemius. Muscle loaded only with a rather heavy lever. Magnification, 5. Temp., 15° C. Time marker, 100 per sec. (A.P.B.)

pull on it (inertia of motion), and so makes the muscle appear to have shortened more than it really has. For the same reason, during the period of shortening, the tension on the muscle is not uniform, but becomes less as the lever undergoes acceleration; during the relaxation exactly the opposite happens, a heavy lever as it falls again undergoes acceleration and increases the tension on the muscle throughout the relaxation and may even stretch it beyond its original resting length (Fig. 34). In order to reduce these errors the lever again should be as light as possible.

On the other hand, to attach to the muscle no other weight than that of a very light lever would introduce fallacies. For, unless the muscle is sufficiently weighted to keep it taut, there may be, when the muscle begins to contract, a certain amount of 'slack' to be taken in which would cause an apparent lengthening of the latent period:

Again, when the muscle does begin to pull on the lever, it will do so with a sudden jerk, which may cause a light lever to fly up out of control of the contracting muscle; this, again, makes the muscle appear to have undergone greater shortening than it really has (see, however, Chapter XIII.). Further, the relaxation of a muscle being purely passive, the period of relaxation of an insufficiently weighted muscle is much prolonged, and the writing may fail to reach the base-line again.¹

In order to get over these instrumental difficulties, the muscle-lever must be as light as is consistent with rigidity, and the muscle must be suitably loaded, the weight being attached near the axis of the lever for the following reasons: the nearer it is to the axis, the less movement will it undergo, and therefore the less will be its inertia of movement and the more uniform the tension on the muscle throughout the curve. This disposition of the weight also helps to reduce the after-vibrations or 'shatter'-curves which are frequently seen following the relaxation (Fig. 34). Compare with this Fig. 32 taken from the same muscle; by hanging a weight of 30 grams near the axis of the lever the shatter curves have been nearly eliminated, and are represented by the slight oscillation between the two vertical lines at the end of the curve.

It may be pointed out that in the living body the muscles are always weighted when they contract, and even when relaxed they are under considerable tension; for they are really shorter than the distance between their points of origin and insertion, and their antagonists are always exerting a certain pull on them, and some muscles, such as the deltoid, are considerably stretched by the weight of a limb.

The length of the lever is of some importance; for, besides the fact that length reduces the rigidity of a light lever, a further deformation of the curve is introduced by increasing the magnification. As the writing point is raised, it tends to leave the drum, and in the course of a much magnified curve is only kept on the drum by the lengthening out of the spring formed by the writing point. Therefore the more the writing point is raised above the horizontal, the more the magnification is constantly increasing. For this reason the muscular movement should not be magnified more than is sufficient to make the record of it clear.

Although muscle curves, as accurate records of the muscular move-

¹ Muscles during the cold of winter, even when properly weighted, frequently show this 'contraction-remainder.' If cold be the cause, turn back the 'trouser' of skin and pour over the muscle some normal tap-water saline heated in a test tube to 25° C. Cf. footnote on p. 33.

ment, have fallacies inseparable from the method of recording them, it is possible to make two rough deductions from them :

(1) The amount of actual shortening a muscle undergoes during contraction can be calculated by measuring the vertical height of the top of the curve above the base line and dividing it by the magnification ; in Fig. 32 the height is 20 mm., and the magnification 5, therefore the muscle became shorter by 4 mm. The length of the resting muscle when loaded by lever and weight was 25 mm., consequently the muscle during contraction became shorter by $4 \times \frac{1}{5}$, *i.e.* nearly a sixth of its original length.

(2) The amount of work done by the muscle during its contraction is the product of the load and the height to which it was raised, $W = L \times H$. In Fig. 32 the actual load which the muscle raised was not the whole of the 30 grams, hung near the axis of the lever, but a proportion of it, calculated by multiplying by the distance from the axis of the point of the suspension of the weight, and dividing by the distance from the axis of the point of attachment of the muscle ; this fraction was $\frac{1}{5}$, and the actual load lifted 6 grams. The height to which it was raised was 4 mm. ; consequently the work performed was 24 gramme millimetres.

CHAPTER IV.

THE CONDITIONS WHICH AFFECT SINGLE MUSCULAR CONTRACTIONS.

(a) **Different Muscles.** (b) **Veratrine.**—The curve produced by the contraction of a muscle may be altered not only by such influences as temperature, load, fatigue, and drugs, but also by the differences in structure of various muscles. The muscular fibres of the frog are found to present two varieties, clear and granular, which differ both in structure and in physiological properties. The gastrocnemius may be taken as an example of a muscle whose fibres consist largely of the clear variety, and the hyoglossus of the granular variety, *i.e.* a muscle in which the majority of muscle-fibres contain more nuclei and are relatively richer in undifferentiated living material, the sarcoplasm. The chief physiological difference between granular and clear muscles are, that granular muscles have a slower and more prolonged contraction, are less excitable, more easily tetanised, and less readily fatigued.

In mammals the same differences between red and white muscles can be shown to exist. Red muscles, such as the masseter or soleus of the rabbit, differ structurally in having more sarcoplasm and nuclei in their fibres, and are redder in colour owing to a much richer capillary net-

work between their fibres and to the presence of myohaematin in the fibres themselves ; physiologically they are far less readily fatigued and show a contraction four or more times as long as that of the white gastrocnemius (Fig. 35).

For comparison with the single twitch of the gastrocnemius, that given by the hyoglossus may now be studied. This muscle, arising from the anterior edge of the body of the hyoid cartilage, runs forwards into the substance of the tongue.

A **Hyoglossus Preparation** is made by cutting off the whole of the lower jaw, including the tongue and hyoid cartilage. Place it on the myograph board, mucous surface upwards, turn the tongue

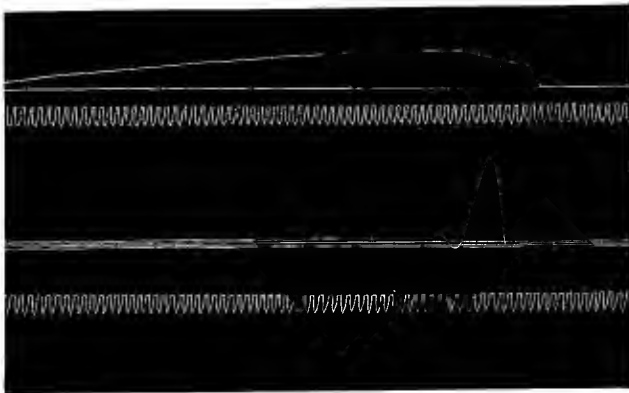

FIG. 35.—Comparison of contractions of red and white muscle of rabbit, stimulated indirectly. Upper curve is response of the red soleus and lower curve that of the white gastrocnemius. Time marker, 50 per sec. The tracing to be read from right to left. (M.S.P.)

forwards, and connect its tip to the lever by a thread. Firmly fix the hyoid cartilage by running a pin through it into the cork. Two needle electrodes transfix the base of the muscle just in front of the hyoid.

All the other connections are the same as when studying the single contraction of the gastrocnemius ; a weight of 5 or 10 grams is placed near the axis of the lever.

Compared with the single twitch of the gastrocnemius, that given by the hyoglossus (Fig. 36) shows the following differences : the whole contraction lasts more than twice as long, the latent period is slightly longer, but it is the period of shortening and still more that of relaxation which is more gradual and prolonged.

Action of Veratrine.—A brainless frog is poisoned by injecting into the dorsal lymph sac 5 minims of a saturated (1 in 1000) solution of veratrine in normal tap-water saline. In order that the drug may

be rapidly absorbed it is important not to 'pith' the frog, but to destroy its cerebrum with a pair of Spencer-Wells pressure forceps. In about ten minutes it will be observed that the hind legs are very slowly and imperfectly flexed after a jump, and a few minutes later the frog will be seized by a spasm when it jumps. As soon as these



FIG. 36.—Contraction of the hyoglossus muscle. Time marker, 100 per second. (A.P.B.)

symptoms appear the remaining portions of the central nervous system are destroyed, and a sciatic and gastrocnemius preparation made.

In the meantime the action of veratrine may be studied on the hyoglossus preparation used in the previous experiment. Five minims of the veratrine solution are injected into the lymph sac in which the muscle lies. The drum is arranged to revolve at a slow rate of about 2 cm. in 10 secs., and a simple key instead of the "striker" of the drum is placed in the primary circuit. After waiting a few minutes the muscle is stimulated by a single maximal induction-

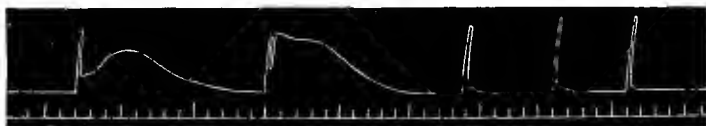

FIG. 37.—Contraction of the gastrocnemius muscle of a frog. The effect of veratrine. The first two contractions show the characteristic effect of the drug; further stimulation produced twitches without the prolonged contraction. The curve has been reduced to one-half the actual size. The time is marked in seconds. (Pembrey and Phillips.)

shock, and its contraction recorded. The curve shows that the response is a single slow contraction with an enormously prolonged relaxation.

Replace the hyoglossus by the gastrocnemius and sciatic preparation and stimulate it in the same way. As soon as the first contraction is over, the muscle is stimulated again, and so on for half a dozen contractions. It will be seen that the first contraction (Fig. 36) consists of a smart initial twitch followed by a much longer contraction, and an even more prolonged relaxation. The second contraction shows the same characters to a less extent, and the subsequent contractions become of shorter and shorter duration until they reach the

normal. If the muscle be allowed to rest, the veratrine effect returns again. The absence, in the case of the hyoglossus, of the sharp initial twitch seen in the gastrocnemius contraction, is probably due to more complete poisoning of all the muscle-fibres. The gastrocnemius is more bulky, some of its fibres remain unpoisoned and respond with a normally rapid contraction, followed by the slower and more prolonged contraction of the poisoned fibres.

CHAPTER V.

THE CONDITIONS WHICH AFFECT SINGLE MUSCULAR CONTRACTIONS—CONTINUED.

(c) **Temperature.**—Since the shortening of muscle during its contraction is but the outward and visible sign of chemical changes taking place in the muscle, it is not surprising that changes in temperature should greatly affect the single muscle-twitch.

In warm-blooded animals whose bodily temperature does not undergo a greater variation than about 2° C., the effect of different temperatures on muscular activity is unimportant. But it is quite otherwise in cold-blooded animals whose range of bodily temperature is that of their external medium. In them, the muscular activity of which they are capable at any moment is determined largely by the temperature of their muscles. Again, the subject becomes important for warm-blooded animals when, from any cause, their bodily temperature is materially altered, as it may be by disease. These abnormal variations in their temperature may be sufficiently great to affect the muscular activity of which the animal is capable. More frequently, however, they are important because of the effect which an abnormally high bodily temperature, especially when long continued, may have upon the actual chemical constituents of muscle, and especially upon its proteids.

In order to study these effects, the apparatus is arranged to stimulate a muscle with single maximal induction shocks, using the "striker" of the drum, in the primary circuit. Either a hyoglossus or gastrocnemius preparation may be used; if the latter, it must be prepared without a covering of skin, in order that its temperature may be more readily altered. Also, the muscle must be stimulated directly and not through its nerve, since changes of temperature affect nerve.

It is important to use maximal stimuli, for cold increases the excitability of muscle, and a stimulus which is minimal at 5° C. will be sub-minimal at 25°. The lever should be weighted near its axis and the drum should revolve at a rate of about 20 cm. per sec.

Cold tap-water saline solution, which has been cooled by ice to nearly 0° C., is slowly poured upon the muscle; the temperature of the solution is noted, the muscle is stimulated, its contraction recorded and the point along the tracing at which the stimulus was sent into the muscle is marked. Swing the writing point off the drum, but do not move the base of the stand carrying the myograph. Take a series of superimposed curves at temperatures of about 3°, 13°, 23°, and 33° C. (Fig. 38). Sufficient time must be given and fluid used to allow the bulk of the thick gastrocnemius to attain approximately the temperature of the saline solution. In order to get exact results, it would be necessary to

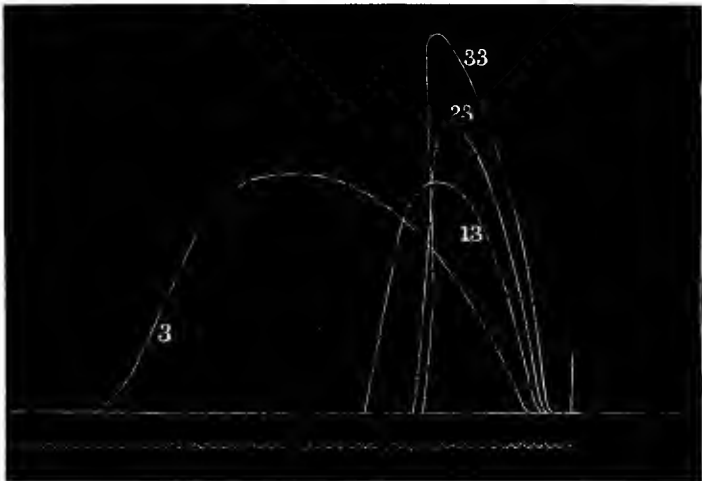

FIG. 38.—The effect of temperature upon the contraction of the gastrocnemius muscle. The time is marked in $\frac{1}{100}$ second. The tracing should be read from right to left. Figures on curve are the temperatures of the salt solution. (Pembrey and Phillips.)

suspend the muscle in the solution at a given temperature until its substance had attained that temperature.

It will be seen that cold lengthens the whole curve, especially the latent period and the phase of active contraction; the period of relaxation is relatively less affected, but a tendency to incomplete relaxation is often seen.¹ As the muscle is warmed, the liberation of energy becomes more and more rapid, consequently the time occupied by the whole twitch decreases progressively, and especially the latent period and period of shortening; the passive stage of relaxation is

¹ Cooled excised muscles, even when weighted, are liable to show a 'contraction-remainder,' or incomplete return to their former length after contraction. It is also seen after strong direct stimulation, in poisoning with veratrine, and as fatigue or death come on.

relatively less shortened, although muscle does become more extensible as its temperature rises from 0° to 30° C. (Fig. 38).

The relation between temperature and the height of the contraction is not quite so simple. Between 0° and about 15° C. the actual height of the contraction may fall slightly, and for two reasons: as the temperature increases, the irritability of the muscle decreases; further, other things being equal, the more slowly a muscle contracts, the more time it has to shorten up as much as it will in response to a given stimulus. From 15° to 25° the height of the curve rapidly increases; this is largely, if not entirely, instrumental in origin, and is



FIG. 39.—Curve of the shortening of the gastrocnemius muscle during heat-rigor. (Pembrey and Phillips.)

due to the fact that, as the liberation of energy becomes more rapid, the lever receives a considerable jerk from the rapidly contracting muscle. In other words, the increased height of the contraction is due, not to a greater liberation of energy, but to the greater rate at which the same quantity of energy is liberated. From 25° to 35° C. the irritability of muscle and its height of contraction rapidly fall.

Now pour on some solution warmed to 50° C. When the muscle-fibres reach a temperature of about 40° C. they undergo a rapid shortening (Fig. 39), which, as the temperature of the muscle rises, passes into the permanent shortening of 'heat-rigor.' This condition is due to coagulation of some of the muscle proteids, and in consequence the muscle becomes hard, opaque, inelastic, and has permanently lost its irritability.

CHAPTER VI.

THE CONDITIONS WHICH AFFECT SINGLE MUSCULAR
CONTRACTIONS—CONTINUED.

(d) **Load.**—In order to study the effect of variations in load upon a single muscular contraction, the apparatus is arranged for stimulating the muscle by a single maximal induction-shock, the drum being placed as a key in the primary circuit and arranged to rotate at a fast rate. Make a gastrocnemius-sciatic or hyoglossus preparation.

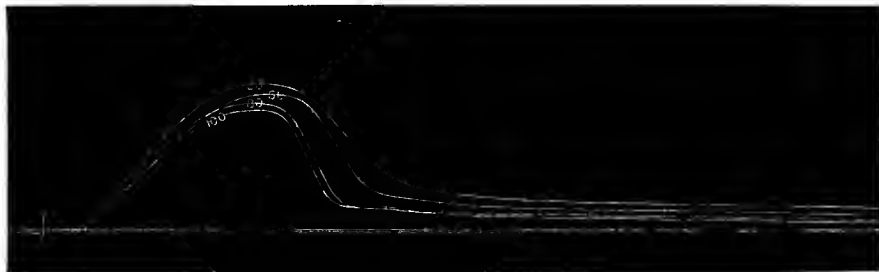

FIG. 40.—The effect of load upon the contraction of the gastrocnemius muscle (A.P.B.)

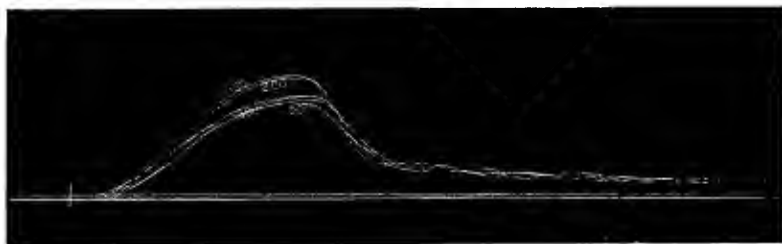

FIG. 41 is the continuation of the experiment in Fig. 40. Single contractions of the gastrocnemius with different loads. The figures on the curves represent the weights in grms. hung at the axis of the lever; actual load on muscle was in each case one-fifth. Magnification, 5. Temp., 12° C. (A.P.B.)

Record a single contraction of the muscle weighted only by the lever, mark the latent period and draw a base-line. Then hang on to the lever near its axis weights increasing by 20 grams at a time, and for each addition of weight record a contraction. The base of the stand carrying the myograph should not be moved during the experiments, but the curves should be superimposed as in Figs. 40 and 41. Each increase of weight stretches the muscle, consequently it is

necessary to bring back the writing point accurately on to the base-line before each contraction is recorded.

The general effects to be noticed are—that, as the load is increased, the latent period becomes slightly longer, the height of the contraction generally becomes less, the rise of the lever during the period of active contraction becomes more gradual, and the period of relaxation, which may be at first much decreased, gradually lengthens out again.

If the muscle be fresh and in really good condition, the early effect of increasing the load may be to increase the height of the first few contractions (Fig. 43). This stimulatory effect of initial tension on the power of a muscle to liberate energy during a subsequent contraction, is seen, within certain limits, in all kinds of muscular tissue; and it is of importance. For, in the body, as has been already pointed out, the skeletal muscles are, even when relaxed, under a certain tension produced by the pull of their antagonists and their being really shorter than the distance between their points of origin and insertion.

But when we study the work done by the muscle during a series of contractions with increasing loads, and not merely the height of the individual contractions, the stimulating effect of increased load is much more obvious. After the tracing has been varnished and dried, measure off the vertical heights of the curves corresponding to the different loads, and calculate the work done during each contraction (see p. 29). In the following table are given the details of the work done during the contractions recorded in Figs. 40, 41.

Number on Contraction.	Actual Load in grms.	Actual Height of Contraction in mm.	Work done in grm. mm.
20	4	4	16
50	10	3·8	38
80	16	3·6	57·6
100	20	3·4	68
150	30	3·3	99
200	40	3·2	128
300	60	2·8	168
500	100	2·6	260

It will be seen that, although the height of the contraction decreases as the load increases, the work performed increases throughout. This process of course has limits, which will be dealt with on p. 60. The important deduction to be made from these results is that muscle as



FIG. 42. — Single contractions of the hyoglossus with different loads. The figures on the curves represent the weights in grms. hung at the axis of the lever; actual load on muscle in each case, one-fifth. Magnification, 5. Temp., 12° C. Time marker 100 per sec. (A.P.B.)

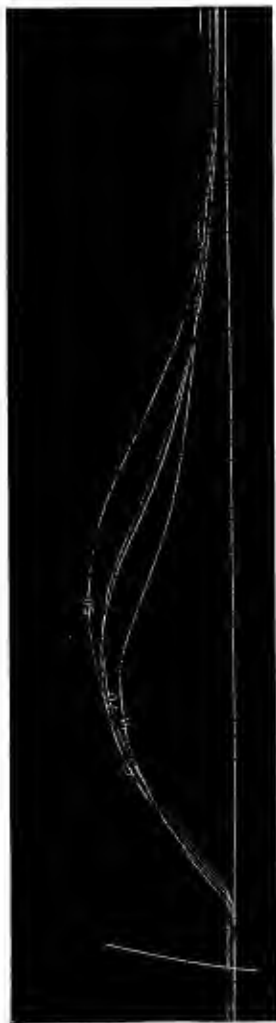

FIG. 43. — Single contractions of gastrocnemius, showing increased height of contraction as the load is increased. (A.P.B.)

a machine for doing work is found to have its output of energy regulated, not merely by the strength of the stimulus reaching it, but also to a large extent by the amount of work it is called upon to do (see p. 60).

Effect of Fatigue.—When discussing the fatigue of muscle it is necessary to draw a distinction between the fatigue of a movement produced by the voluntary contractions of the muscle concerned in it (see p. 70), and the fatigue of a muscle caused by the artificial stimulation of the muscle itself or of the nerve supplying it (see p. 72). Further, in the second case there is a marked difference in the effect of continued stimulations on a muscle whose circulation is still intact (see p. 74), and on one which has been excised from the body. Here we shall deal only with the simplest case of a muscle excised from the body and stimulated directly and not through its nerve, in order to exclude any possibility of fatigue of nerve or of nerve endings.

Prepare either a hyoglossus preparation to be stimulated by two needle electrodes, or a gastrocnemius-sciatic preparation to be stimulated by one needle-electrode and by fine capillary copper wire threaded through the tendo-Achillis, as the other electrode. The drum is placed in the primary circuit, so that each time it revolves the muscle receives a maximal make induction-shock; it should revolve at such a speed that the muscle will be stimulated once or twice a second. Weight the muscle near the axis of the lever, using 20 grms. for a hyoglossus and 50 grms. for a gastrocnemius preparation. With the Du Bois key closed, describe a base line and mark on it the point at which the stimulus will enter the muscle. Now open the Du Bois key, allow the drum to revolve, and record the first contraction and every tenth or twentieth subsequent contraction. For this purpose, directly the first contraction is over, the writing point is swung away from the drum, which goes on revolving and causing the muscle to contract. The base of the stand carrying the myograph must not be moved so that for each contraction the point of entrance of the stimulus will be the same. The writing point should be a fine one, otherwise the number of superimposed curves will to some extent obliterate each other.

When a series of curves taken in this way is examined (Fig. 43) it is seen that they show the following changes as fatigue progresses,—the latent period becomes slightly longer, the shortening of the muscle takes place more slowly and reaches its maximum more gradually, but the actual height of the curves does not begin to decrease much until the other features of fatigue are well marked; the lengthening out of the period of relaxation is the most marked feature, it is evident from the first, and, as it progresses, a 'contraction remainder' also appears.



FIG. 44.—Series of contractions of gastrocnemius to show the change in contraction as the muscle becomes fatigued. Every twentieth contract recorded. Actual load on muscle, 10 grms. Magnification, 5. Temp., 12° C. Time tracing, 100 per sec. (A. P. B.)



FIG. 45.—Exhaustion curve of excised and loaded gastrocnemius. Muscle was stimulated with a maximal shock every 6 secs. Exhaustion was complete at the end of 16 minutes. A slight recovery curve is shown at the end of 6 minutes rest. (H. S. F.)

The rate at which fatigue comes on in a muscle under the above conditions is increased by raising the temperature and the load.

Another method of studying the effects of fatigue on a hyoglossus or gastrocnemius muscle is as follows. In this case the primary circuit is made and broken by hand, and the contractions are recorded as nearly straight lines on a drum revolving at the slowest possible speed. The secondary coil is moved up to the primary until both make and break shocks are maximal, and the muscle receives a stimulus once every 5 secs. In this way Fig. 45 was produced. It will be seen that the height of the contractions, after remaining fairly constant at the beginning, gradually decreases until, at the end of 15 minutes, the muscle was incapable of lifting the load. Further, it is seen that in the last two-thirds of the tracing the basal points of the twitches gradually fail to reach the base line, thus showing a 'contraction remainder.' If the muscle had been stimulated at shorter intervals, this appearance would have come on earlier; for, as soon as the period of relaxation began to increase, the next stimulus would have reached the muscle before there had been time for relaxation to be completed.

If the muscle be allowed to rest for a few minutes and then the stimulation is continued, it will be found that even excised muscle is capable of slight recovery from fatigue (Fig. 45).

One other point shown by Fig. 45 must be referred to; the height of the first twenty twitches increases, showing a 'stair-case' effect. This short and temporary improvement in the condition of muscle, brought about by the repetition of a stimulus of constant strength, was at one time thought to be peculiar to cardiac muscle (see Heart); but although shown best perhaps by the heart, it is also shown by all forms of muscular tissue.

CHAPTER VII.

TWO SUCCESSIVE STIMULI. GENESIS OF TETANUS. TETANUS.

WHEN a second stimulus reaches a muscle after the contraction caused by the first is over, the muscle responds with a second contraction similar to or perhaps slightly higher than the first (see Fig. 45). When, however, the second stimulus reaches the muscle before the contraction caused by the first is completed, the response given by the muscle to the second stimulus depends upon the exact phase of its twitch, in which it happens to be when the second stimulus reaches it.

In order to investigate this point, arrange the drum and circuits as



A

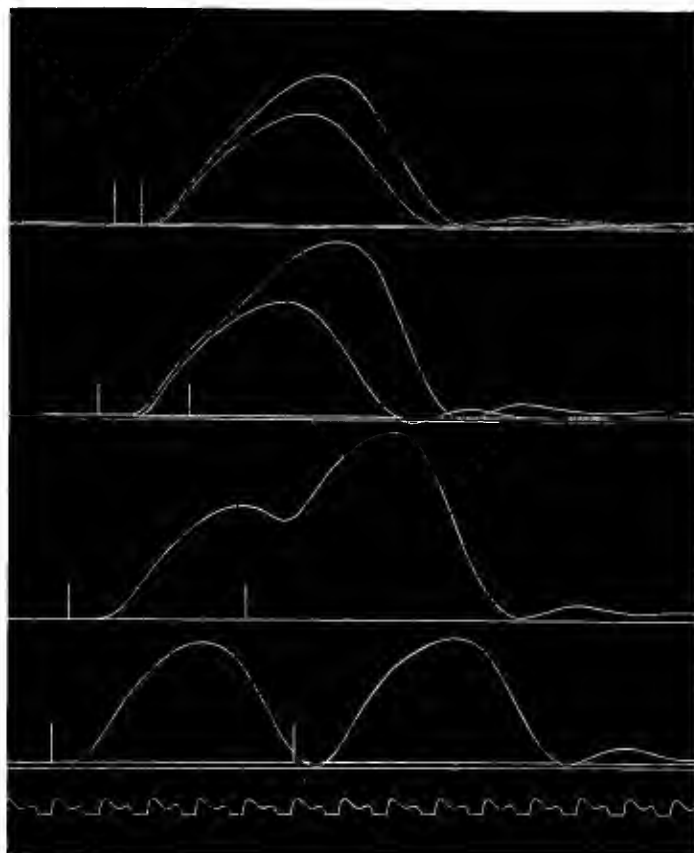

B

FIG. 46.—Effect of two successive maximal stimuli, with gradually diminishing intervals, upon the gastrocnemius. To be read from below upwards.

B. Time tracing, 50 per sec. In the two upper curves are shown both the contraction in response to the first stimulus alone and the combined contractions caused by the two successive stimuli. (M.S.P.)

A. Time tracing, 100 per sec. Recorded on a drum revolving at a much faster rate. The second stimulus was sent in well within the latent period of the first. (A.P.B.)

in experiments for recording a single maximal contraction on a rapidly revolving drum (p. 24); it is only necessary in addition to place a second 'striker' in the primary circuit through the drum. If the rate of revolution of the drum remains constant, then, by simply altering the angular distance between the two 'strikers,' a second stimulus can be sent in at varying intervals after the first. Make a gastrocnemius preparation and stimulate it either directly or through its nerve. Set the drum in motion and, with the Du Bois key open, approximate the 'strikers' until the muscle clearly to the eye just responds with a complete contraction to each stimulus. Close the Du Bois key, bring the writing point on to the bottom of the drum, describe a base line and mark on it the point at which each stimulus enters the preparation; then open the key, record both contractions, and close the key again. Now raise the myograph until the writing point will just clear the top of the curves, approximate the strikers a little, and again record the contractions, after marking a base line and the points of entrance of the two stimuli. This process is repeated until the 'strikers' are finally at such a distance apart that the second stimulus falls within the latent period of the first.

In this way Figs. 46 A and B were obtained. It shows that when a second maximal stimulus reaches a muscle during any part of its period of relaxation or of shortening, the rest of the contraction due to the first stimulus is omitted and the muscle starts off on a fresh contraction in response to the new stimulus. Since the second contraction may be as high as the first and starts with the writing point above the base line, it follows that the height of the second twitch above the abscissa is greater than and may be nearly double that of a single contraction; in other words, a summation of contraction has taken place. If, however, the second stimulus falls within the latent period of the first, then the muscle responds by a contraction only to the first stimulus (Fig. 46 A); that is, the muscle is refractory to the second stimulus so far as its being able to respond by a second contraction is concerned; therefore in skeletal muscle the 'refractory' period corresponds in time to the latent period (cf. the 'refractory' period of cardiac muscle, p. 64).

Genesis of Tetanus.—In order to study the response of a muscle to a series of stimuli, it is necessary to have an apparatus which will automatically make and break the primary circuit of an induction coil at any desired rate.

The vibrating reed is a convenient form and consists of a flat steel spring which can be clamped in various positions along its length; by altering the length of spring which is allowed to vibrate, the number of

vibrations per second can be changed. The spring has numbers stamped on its upper surface, corresponding to the position at which it must be clamped to give that number of complete vibrations per second. The free end of the spring carries a platinum point which makes and breaks contact with a mercury cup in connection with the primary circuit (Fig. 47). In order to maintain the vibrations of the spring it is usual to place above it, and in the same circuit, an electro-magnet, so that, when the spring makes contact with the mercury, it is attracted out of the cup again by the magnet. In performing a complete vibration, the spring will both make and break the primary circuit and, in order that the two stimuli may not cause contractions of unequal height, the secondary coil must be so placed that either the make shock is just

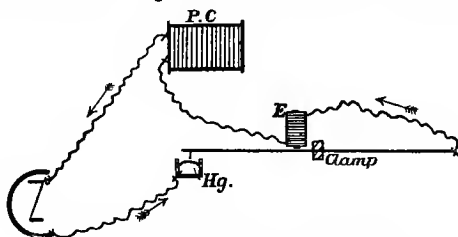

FIG. 47.—Diagram of the vibrating reed in circuit.

ineffective, in which case the number of effective stimuli per sec. will be the same as the number of complete vibrations of the spring, or the make and break shocks are made equal and maximal, in which case the number of contractions per sec. will be double that of the complete vibrations of the spring.

Place the vibrating reed in the primary circuit so as to give 10 effective stimuli per sec. Make a gastrocnemius and sciatic preparation, with the Du Bois key closed, set the spring vibrating and bring the writing point of the myograph on to the surface of the drum, rotating at a slow rate, about 3 to 4 cm. per sec.; open the Du Bois key and record the contractions for about 1 sec. Stop the drum, adjust the spring to give 20 effective stimuli per sec., and record the contractions as before. Repeat again with 30 stimuli per sec. Then remove the vibrating reed from the primary circuit, connect the battery with the coil so as to set the Wagner's hammer vibrating, and record the contraction of the muscle for a few seconds.

Since each twitch of a gastrocnemius at 20° C. lasts about $\frac{1}{10}$ th sec., a muscle at that temperature could just respond without any summation to 10 stimuli per sec. If, however, the muscle is colder or fatigued, and each contraction therefore lasts longer, with 10 stimuli per sec., some slight summation may be seen, *i.e.* relaxation is not complete before the next

contraction begins, and the line joining the apices and basis of the successive contraction ascends slightly. With 20 stimuli per sec. the summation and fusion of each individual contraction is more complete; but the apex of each individual contraction will probably still be seen: the curve is therefore one of incomplete tetanus (Fig. 48). With 30 stimuli per sec. fusion may be complete from the first, *i.e.* complete tetanus, or if not complete at first, it gradually becomes so. This gradually increasing fusion (Fig. 48) is really due to fatigue: for the period of relaxation of the individual contraction tends to become longer and longer, and therefore the next stimulus reaches the muscle progressively earlier in each individual twitch, until a point is reached in which there is no time for the muscle to begin to relax between the stimuli, and fusion becomes complete. With the Wagner's hammer, which causes the muscle to receive 50 or more stimuli per sec., fusion is complete from the first. One other point is to be noted in nearly all these curves: at first the rise in the lever is very rapid, then it suddenly becomes more gradual, but, even when fusion has been complete from the first, the lever may still rise slowly for a short time until the muscle has reached the utmost shortening of which it is capable. If the stimulation is still continued, this height may be maintained for a short time, but sooner or later the lever will begin to drop, showing the onset of marked fatigue. In all cases when the stimulation ceases, the relaxation is at first extremely rapid, then becomes more gradual and a 'contraction-remainder' varying in extent according to the degree of fatigue is generally seen.

The same experiments may be performed with a hyoglossus preparation. This muscle, however, being of the 'granular' variety and having a contraction which lasts twice as long as that of the 'clear gastrocnemius' (see p. 30), is sent into complete tetanus with half the number of stimuli, *i.e.* about 15 per sec.

CHAPTER VIII.

THE PROPERTIES OF NERVE, MINIMAL AND MAXIMAL STIMULI.

A NERVE is not a unit; it is that branch of a nerve-cell which conducts an impulse to, or from, the periphery. A nerve-cell with its dendrites and axis-cylinder process or *axon* forms a unit, the *neuron*. It is convenient, however, to examine the characteristics of a nerve apart from its nerve-cell. The chief of these are *excitability* and *conductivity*. Excitability, or, as it is sometimes called, *irritability*, is the response to a



FIG. 48.—Incomplete tetanus of gastrocnemius. 20 stimuli per sec. Temp. 15° C. (M.S.P.)



FIG. 49.—Same preparation as Fig. 48. 30 stimuli per sec. Time marker, 50 per sec. Temp., 15° C. (M.S.P.)

stimulus; a nervous impulse, the real nature of which is unknown, is started at the point stimulated, and is transmitted or conducted along the nerve.

Nerves can be stimulated by electrical, mechanical, chemical or thermal agents; of these the most important in experimental physiology is the electrical, for it can be finely graduated, is of extremely short duration, and can be applied repeatedly without damage to the nerve. The first experiments will therefore be the electrical stimulation of nerve.

The Electrical Stimulation of Nerve.—An induction-apparatus is arranged for single induction-shocks, and a simple pair of electrodes is connected with the secondary coil by means of a Du Bois key. A preparation of the sciatic nerve in its entire length and of the gastrocnemius muscle of a pithed frog is made, and near the origin of the nerve is applied the pair of electrodes.

On the passage of an induction-current through the electrodes the nerve is stimulated, and an impulse is sent down the nerve, reaches the muscle, and causes it to contract. This is *indirect* stimulation of the muscle, and is, if a weak current be used, not due to an escape of the electric current along the nerve towards the muscle. This is proved by the following experiment. A moistened thread is tightly tied round the nerve at a point between the electrodes and the muscle. The passage of a weak induction-current of the same strength as that previously used will stimulate the upper portion of the nerve, but the nervous impulse will not pass through the block produced by the thread. A breach in the physiological continuity has been produced, and the nervous impulse is not conducted through the ligatured nerve. The moistened thread would not prevent the passage of a purely electric current.

The response of the nerve to a stimulus bears within certain limits a relation to the strength of the stimulus. This can be shown by the following experiment.

Maximal and Minimal Stimuli.—The muscle of the preparation is attached to a myograph, the lever of which is arranged to write upon a drum covered with smoked paper. The electrodes are placed between the muscle and the ligatured portion of the nerve which was used in the previous experiment. The induction shock is made so weak that no response is obtained, and is then gradually increased until a contraction is observed with the break-shock. Contraction does not follow each break-shock; the stimulus is *sub-minimal*. The contraction is recorded as a vertical line upon the stationary drum, and before each stimulation the drum

is turned by hand about half an inch. The strength of the current is slowly increased until a small contraction follows each break-shock; this is the *minimal* stimulus. The distance in centimetres of the secondary from the primary coil is noted upon the drum. The make-shock is weaker than the break, so that it is necessary to use only the one or the other in this experiment.

The intensity of the current is still further increased until the most powerful contraction of the muscle, as indicated by the height of the nearly vertical lines upon the drum, is obtained; the stimulus is now *maximal*. Any further increase in the strength of the stimulus is not accompanied by a bigger contraction; a *supra-maximal* stimulus only produces a maximal contraction, and is liable to damage the nerve.

It may be, as Gotch has suggested, that the difference between maximal and minimal stimulation depends upon the number of the constituent fibres of the nerve stimulated. A weak electric current may affect only a few fibres, and therefore the result will be only a slight contraction, due to the excitation of those muscle-fibres alone which are supplied by the nerve-fibres.

It will be found that the excitability of the nerve changes, so that with the same strength of stimulus there will not be the same minimal point. A loss of excitability readily occurs if the nerve be allowed to dry, but during this process there may be irregular fluctuations in the excitability of the nerve above and below the normal.

Mechanical Stimulation of the nerve can be shown by pinching the nerve with a pair of forceps; the muscle contracts, showing that a nervous impulse was produced. Such a method of stimulation injures the nerve, but by means of simple arrangements a nerve can be stimulated mechanically without damage. A light hammer worked by an electro-magnet may be used to tap the nerve, or small drops of mercury from a funnel may be allowed to fall upon the nerve. Such methods are useful in experiments in which an electrical stimulus might introduce a source of fallacy, but for ordinary experiments they are undesirable, since there is a difficulty in maintaining a constant strength of stimulus, and there is a danger of damage to the nerve.

Thermal Stimulation is next shown by the application of a hot wire to the nerve. The muscle contracts. The damaged portion of the nerve is cut away, and to the end of the living nerve is applied a crystal of common salt; the muscle soon shows irregular twitches due to the **chemical stimulation** of its nerve. The last form of stimulus is obviously limited to special experiments, for the stimulus is not easily graduated and damages the nerve.

CHAPTER IX.

THE RELATION BETWEEN MUSCLE AND NERVE.

THE motor nerves by means of their end-plates are so intimately connected with the muscle-fibres that it is impossible to stimulate the muscle-substance alone by the direct application of a pair of electrodes to the intact muscle. The question, therefore, arises whether muscle possesses *independent excitability*, whether it can respond to a stimulus without the intervention of its nerve. The development of muscle from protoplasm, which is contractile and excitable although possessing no nerves, would suggest that muscle itself is excitable and can respond to a stimulus. This can be shown, for the fully developed muscle, after its nerve has been paralysed by the action of a drug.

Curare¹ is an alkaloid used as an arrow-poison by some natives of South America. The following experiments show that it paralyses the terminations of the motor nerves, but that the muscle still responds to direct stimulation :

(i) Two watch-glasses are almost filled with a 1 per cent. solution of curare in normal tap-water saline. Two muscle and nerve-preparations are made, care being taken to bisect the lower portion of the vertebral column and thus obtain the entire length of the sciatic nerve. The excitability of the nerve and of the muscle in the case of each preparation is tested by the determination of the minimal stimuli. Then the nerve of preparation A is placed in one watch-glass full of the poison, but its muscle is left outside upon a piece of filter-paper moistened with normal tap-water saline. The gastrocnemius muscle of the preparation B is placed in the solution of the drug and its nerve upon the damp filter-paper (Fig. 50). Stimulation of the nerve B will soon produce no contraction, even if the strongest induction-shocks be used; on the other hand, an examination of the nerve A will show that its excitability has practically undergone no decrease. Stimulation of the muscle B which has been exposed to the action of the drug readily produces a contraction. The poison, therefore, must act upon some portion of the terminations of the nerves, probably upon the end-plates, for both muscle-substance and nerve-trunk retain their excitability even after long exposure to the drug.

Muscle will contract on direct stimulation even after its nerves have degenerated. This experiment, however, is not suitable for a class, for it would be necessary to keep the animal alive for two or three weeks in order that the nerve-fibres might completely degenerate.

¹ It is prepared from various plants of the genus *Strychnos*.

A further experiment with curare can be made. (ii) The cerebral hemispheres of a frog are destroyed, and then the sciatic nerves are carefully exposed in each thigh; a strong ligature is passed under the sciatic nerve of one side, A, and is tied tightly around all the structures of the thigh except the nerve. The circulation of the blood is thus completely stopped in the structures below the ligature. Stimulation of either sciatic nerve produces a contraction of the muscles of the corresponding leg. Under the skin of the back of the frog are injected two or three drops of a 1 per cent. solution of curare. The poison is

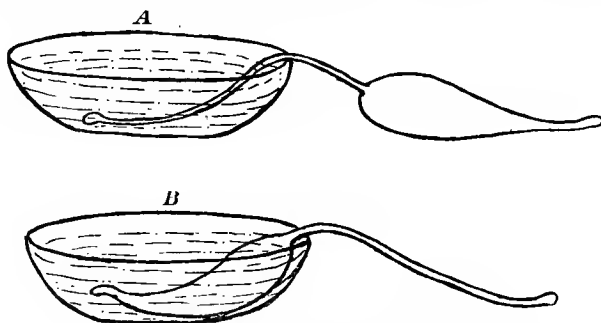

FIG. 50.—Diagram of the experiment on the action of curare.

absorbed by the blood-vessels and is circulated in all parts of the body except those below the ligature. Paralysis is produced, and the frog lies in a toneless condition and does not move if its toes be pinched. Stimulation of the sciatic nerve produces in the case of the ligatured leg, A, a contraction of the muscles, but in the case of the other leg, B, no contraction occurs. The muscles, however, of the leg, B, contract on direct stimulation.

Both nerves in their upper portions have been exposed to the poison, the muscles of both legs respond to direct excitation, but the ligatured leg alone to indirect stimulation. The ligature has prevented the poison from reaching the terminations of the nerves inside the muscles. It is upon these terminations that the curare acts.

The independent excitability of muscle can also be shown in the case of cardiac muscle. The apex of the ventricle of the frog's heart contains no ganglia, but it responds to a stimulus, and under appropriate conditions will even contract rhythmically.

Further experiments upon the independent excitability of muscle are given in Chapter XX.

¹This operation should be performed with a pair of Spencer-Wells pressure-forceps in order that no blood may be lost.

CHAPTER X.

THE EFFECT OF A CONSTANT CURRENT UPON MUSCLE AND NERVE.

MUSCLE and nerve consist of complex chemical substances, and contain about 70 per cent. of water in which various salts are dissolved. Moreover they are bathed in lymph.

The passage of a constant current through a liquid produces electrolysis; thus, in the case of water, oxygen is given off at one plate, hydrogen at the other. Animal tissues, containing, in addition to a large percentage of water, salts and proteins, are also the seat of electrolysis during the passage of a constant current; the ions are probably of a complex nature. These changes in nerve and muscle are shown by alterations in excitability and conductivity.

These it is necessary to consider in relation to the changes which occur at the anode and kathode during the make and break of the

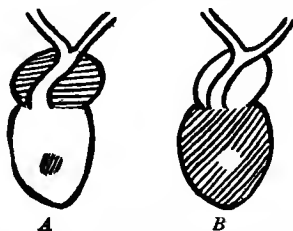

FIG. 51.—Diagram of the frog's heart to show the effects of the make and break of a constant current upon muscle. In A the ventricle is represented as pale and contracted, with a small shaded area to represent the flushed and uncontracted portion of the ventricle; that is, a local diastole during general systole. This condition can be produced by the make of the anode or the break of the kathode of a constant current. In B the ventricle is dilated and flushed, with a small pale area of contracted muscle; that is, a local systole during general diastole. This condition can be produced by the make of the kathode or the break of the anode.

constant current. The simplest experiment can be made upon the frog's heart.

The Effects of Anode and Kathode upon the Frog's Heart.—The brain and spinal cord of a frog are pithed and then the heart is exposed. Care should be taken to avoid the severance of large blood-vessels in order that the vascular system may be well filled with blood. The pericardium is opened and the heart is observed; the ventricle during systole is pale owing to the contraction of its muscle fibres forcing out the blood from its spongy walls; during diastole, when the muscle is relaxed the ventricle is flushed owing to its distension with blood. There are no blood-vessels in a frog's cardiac muscle.

The ends of two pieces of ordinary insulated wire are well cleaned and are connected with a Daniell battery; the clean free ends of the wires are bent back so that there will be smooth surfaces to apply to the heart. The wire connected with the copper of the battery is the *anode*, that with the zinc is the *kathode*.

In the frog's mouth is placed the kathode, for there good contact is obtained with a moist conductor; the anode is placed upon the ventricle. Now it will be found that during the systole of the ventricle that portion of the muscle which is around the anode will be flushed, uncontracted, and bulging outwards—the *anode at the make of the circuit produces a local diastole during general systole* (Fig. 51 A). The rhythmic power of the cardiac muscle around the anode is diminished, so that it remains uncontracted.

If now the wire be suddenly removed from the heart, the break of the anode causes an increased excitability of the muscle to which it had been applied, there is a local pallor; the cardiac muscle is here contracted during the general diastole of the heart. The *break of the anode produces a local systole during a general diastole*.

The kathode is now applied to the heart and the anode is placed in the frog's mouth. There is produced a *local systole during the general diastole of the heart*. The kathode increases the excitability of the cardiac muscle, and thus the fibres affected remain contracted. The end of the wire is kept in contact with the ventricle for about a minute and is then suddenly removed; a flushed and bulging spot will indicate the region to which the wire had been applied. The *break of the kathode produces a local diastole during general systole*, for the disappearance of the condition of katelectrotonus is accompanied by a fall in excitability.

This simple experiment shows that the make of the kathode and the break of the anode excite, that the make of the anode and the break of the kathode depress. This is also true in the case of nerve.

CHAPTER XI.

THE ELECTROMOTIVE PROPERTIES OF MUSCLE AND NERVE.

IN uninjured and resting muscle and nerve there is no electric current, but during activity a current, the '*current of action*,' is produced. Injury causes local activity around the damaged tissue, and is therefore accompanied by an electric current, the so-called '*demarkation* or

injury-current. This electrical current produced by injury is, as Gotch pointed out, to be considered as a *current of action*. These facts can be demonstrated by the following experiments.

The Rheoscopic Frog. Galvani's Experiment, Contraction without Metals.—A long length of the sciatic nerve is dissected in a pithed frog and the muscles of the thigh are exposed and cut across. The trunk of the sciatic nerve is laid along the longitudinal surface of the muscles of the thigh, and then by raising the end of the nerve by a small glass rod the transverse section of the nerve is allowed to fall upon the cut surface of the muscles (Fig. 52). At this moment a twitch of the



FIG. 52.—Diagram of Galvani's experiment. Contraction without metals.

muscles of the leg moves the foot or toes. The circuit of the electric current in the muscle has been completed through the nerve. The section of the muscle-fibres has produced a local contraction of the fibres, and this is accompanied by an electrical change which is sufficient to produce excitation when it is passed through an excitable nerve.

Secondary Contraction or Secondary Twitch.—

Two muscle- and nerve-preparations are made; the nerve of A is so placed upon the muscle B that the cut surface of the nerve lies upon the tendon and its longitudinal surface upon the muscle-fibres (Fig. 53). The nerve of preparation B is stimulated by a weak induction-shock, and thus its muscle is excited and made to contract; the muscle A will also contract. The contraction of the muscle B is accompanied by an electrical current, the '*current of action,*' which passes through the nerve A and thus produces a contraction in the muscle A. This is not due to an escape of electrical current from the electrodes, for a secondary twitch can be obtained if mechanical or thermal stimuli be used to excite the nerve of preparation B. Further, ligature of the nerve B with a moist thread will show that there is no escape with a weak induction-shock; the ligature destroys the physiological continuity and prevents the passage of the excitatory state but not that of an electrical current.

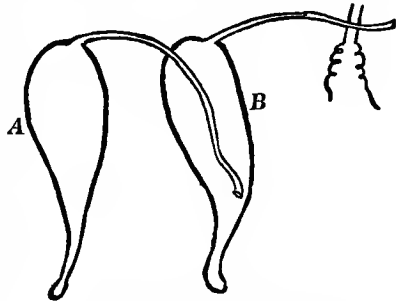

FIG. 53.—Diagram of the experiment on secondary twitch.

Secondary Tetanus.—If the nerve be stimulated with a rapid series of induction-shocks the muscle B goes into tetanus and its ‘*currents of action*’ stimulate the nerve A, with the result that the tetanus is also observed in the muscle A. This ‘secondary tetanus’ can be produced by rapid mechanical stimuli.

Further experiments upon the electromotive properties of muscle and nerve are given in Chapter XXIII.

CHAPTER XII. (*Advanced*).

EXTENSIBILITY AND ELASTICITY OF MUSCLE WHEN AT REST AND CONTRACTED. COMPARISON WITH RUBBER.

MUSCLE is both extensible and elastic, that is, it can be stretched beyond and will return more or less to its original length when the extending force is removed. These are important properties; for, unless muscle were readily extensible the sudden contraction of one set of muscles would in the body be liable to rupture their antagonists.

In the study of these properties a gastrocnemius preparation may be used, but a muscle whose fibres run more nearly parallel to each other is preferable, such as a sartorius preparation from a large frog or better still a gracilis-semimembranosus preparation.

A **gracilis-semimembranosus preparation** consists of the two large internal thigh muscles (Figs. 20, 21). The gracilis is a large muscle lying along the inner side of the sartorius; it arises from the ischial symphysis and is inserted into the head of the tibia. The semimembranosus is a bulky muscle behind the gracilis on the posterior aspect of the thigh; it also arises from the ischial symphysis and is inserted into the back of the head of the tibia. To make the preparation, isolate these two muscles from those surrounding them near their points of insertion, cut through the tibia below this point and through the femur just above the knee joint. Holding this piece of bone, separate the two muscles up to the symphysis and remove with them the bone from which they arise. If a larger or longer muscle still is required, a double preparation may be made with the muscles of both thighs and the two hung side by side, or one below the other, united in the middle by the piece of the symphysis.

The following experiments should be performed. The bone at the

upper end of the preparation is rigidly fixed in a clamp and to the lower end is attached by a short thread or pin a brass mm. scale, having its zero at the bottom. The lower end of the scale has a small tray to carry weights or a hole by which weights can be hooked on. A pointer carried by a separate stand is placed opposite the zero of the scale. A weight of 10 grms. is attached to the scale and the amount of extension read off; then another 10 grms. is added and so on until the load is 100 grms. or more. It will be found that the length to which the muscle is extended is not proportional to the weight used, but that, by each increase of weight the muscle is stretched rather less, the greater the previous extension. By removing the weights one by one the elasticity of the muscle is observed; it is not complete; for when all the weights have been removed the muscle does not at once return to its original length. An 'extension-remainder' is present, and this is the more marked the more the muscle is fatigued by the degree and duration of the extension. Therefore the observations should be made as rapidly and on as fresh a muscle as possible. It is probable that muscle in the body with its circulation intact is completely elastic.

If the muscle is replaced by a suitable piece of rubber band and the same observations are repeated on it, it will be found that the series of elongations are more nearly proportional to the weights used, thus conforming nearly to Hooke's Law, which states that the successive increments in length produced by equal increments of weight are, in a perfectly elastic body, equal. Also, as the weights are successively removed, it will be found that the elasticity of rubber is more nearly perfect. But, if the extension be great and of long duration, an 'extension-remainder' does appear and only gradually disappears.

Another method of demonstrating the same properties is to fix the upper end of a muscle-preparation in the clamp of a simple myograph and to attach its lower end to the lever by a bent pin. Attached to the lever vertically below the muscle is a scale-pan or hook to which weights can be suspended. The writing point of the lever is brought on to the surface of a stationary smoked drum and a zero line described by rotating the drum by hand. The drum is rotated back so that the point of the lever is 5 mm. from the beginning of the zero line, a weight of 10 grms. is attached to the lever, the muscle will be extended and the writing point will record a new vertical line on the drum. Turn the drum by hand so that the writing point will describe a horizontal line 5 mm. long,¹ attach

¹ By thrusting the points of a pair of fine forceps through a thin piece of cork a means of measuring off equal distances is obtained; there is a mm. scale on the induction-coil.

another 10 grms. and repeat the process until 100 grms. or more are extending the muscle. In the same way reverse the process and remove the weights of 10 grms. one by one. If now the lower ends of the vertical lines drawn by the fall and rise of the lever are joined, a curved line will be formed, showing that the extension of the muscle becomes less and less for each additional weight. Further, when all the

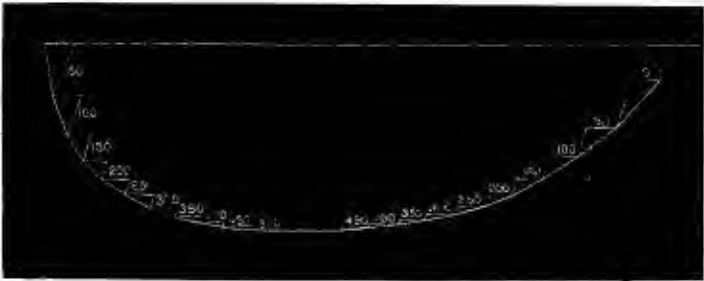

FIG. 54.—Curve of extensibility and elasticity of gastrocnemius. The figures on the curve are weights in grms. Temp., 15° C. (A.P.B.)

weights have been removed, the writing point will be below the original zero line, showing an 'extension-remainder' (Fig. 54). It will also be seen that the line corresponding to the elasticity of the muscle is a flatter and more gradual curve than that corresponding to the extension; this is caused by the long continued load impairing the elasticity of the muscle.



FIG. 55.—Elasticity curve of quiescent muscle. To be read from right to left. The figures on the curve are for weights in grms. (M.S.P.)

If the experiment be repeated on a piece of rubber band, the line joining the lower ends of the vertical lines will be nearly straight, and little or no 'extension-remainder' will be seen. Figs. 55, 56 show a comparison of the lines thus described for a muscle and piece of rubber loaded from 0 to 500 grms. and then gradually unloaded again.

A contracted muscle is more extensible than a resting one. This is of importance in the body; for, otherwise, a sudden and powerful contraction of a muscle, trying to lift a heavy weight, would be liable to rupture either the muscle itself, or its tendon, or the bones to which it

is attached. As a matter of fact, of these three structures muscle, owing to its increased extensibility during contraction, is the least often ruptured. In order to demonstrate this properly the muscle-preparation is attached to the clamp and lever, as in the last experiment. Arrange the apparatus for stimulating the muscle directly with single

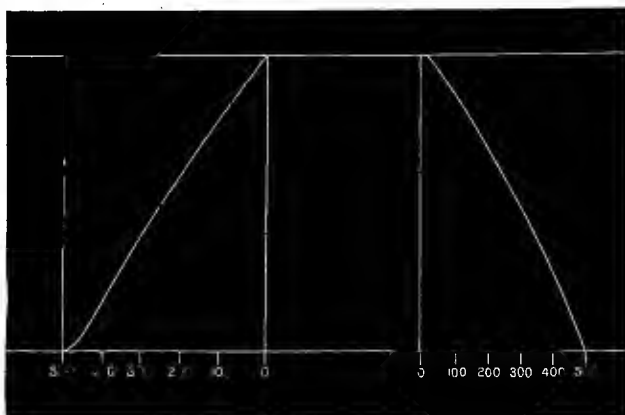

FIG. 56.—Elasticity curve of rubber tubing. The figures represent weights in grms. (M.S.P.)

maximal induction-shocks, using a spring-key in the primary circuit. Bring the writing point on to a stationary drum and, with the muscle weighted only by the lever, describe an abscissa line corresponding to the resting muscle. With the writing point again at the beginning of this line, stimulate the muscle once and, from the top of the ordinate so marked, draw another abscissa line corresponding to the muscle when contracted. Rotate the drum by hand, so that the writing point is now 5 mm. along the 'resting' abscissa line; hang 20 grms. on to the lever and stimulate, so as to record a second ordinate 5 mm. from the first. Repeat this process, increasing the weight by an equal amount each time. In this way Fig. 57 was produced. It is clear that the distance of the lowest point of each ordinate below the 'resting' abscissa line represents the extension of the resting muscle by a given weight, and that the distance of the top of the same ordinate below the 'contracted' abscissa line represents the extension, by the same weight, of the muscle when contracted. If the lowest and then the highest points of the ordinate are joined, two curved lines are produced which represent respectively the curves of extension of resting and contracted muscle (Fig. 57). It will be seen that the extensibility of contracted muscle is absolutely greater, and increases more rapidly, than that of resting muscle. Hence, if the observations were carried

far enough, the two curve lines would ultimately cross; this means that if a muscle were loaded by a weight greater than it could lift, it

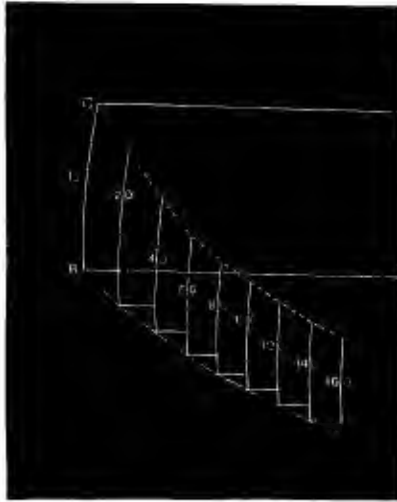

FIG. 57.—Comparative extensibility of resting and contracted gastrocnemius. Temp. 12° C. Magnification, 5. Figures represent actual weights in grms. R is the 'resting' and C the 'contracted' abscissa line. (A.P.B.)

would during its stimulation actually lengthen (Weber's paradox). If this were not so, we should, when trying to lift a load greater than the muscle could move, run a great risk of rupturing our muscles.

CHAPTER XIII. (*Advanced*).

LOAD AND AFTER-LOAD. WORK DONE WITH INCREASING LOADS.

MUSCLES may be loaded in two ways; the load may be applied before the muscle has begun to contract, or only after it has already begun to contract; this latter method, in order to distinguish it from the former, is called 'after-loading.' Most of the muscles in the body are both loaded and after-loaded; that is, they are constantly loaded by the pull of their antagonists, and it is only after they have already begun to shorten that the main load—the weight of the limb, etc.—is applied to them. The deltoid, however, is an instance of a muscle constantly loaded by the weight of the arm; the ventricle of the heart, on the other hand, is a muscle which is only after-loaded.

The effect of load, and of its method of application on a single muscular contraction, will be studied in the following ways: (a) the contraction given by a muscle loaded and after-loaded with the same

weight will be compared; (b) a constant load will be thrown on to a muscle as an after-load later and later in its period of shortening, and the effect on the contractions noted; (c) the muscle being just completely after-loaded, the height of contraction, with increasing loads, will be measured and the work done with each calculated.

Comparison of the Contractions of a Loaded and After-loaded Muscle.—

Arrange the apparatus for stimulating a muscle with single maximal induction shocks, using the drum as a key in the primary circuit. Fix a gastrocnemius preparation to a myograph lever, provided with an after-loading screw; by raising the screw the metal part of the lever can be supported at any level (Fig. 25). Hang a weight of 50 grms. near the axis and raise the screw until the whole of the weight is just after-loaded; this point can be ascertained by supporting the weight with the finger, and when the muscle no longer tends to raise the lever off the after-loading screw, the muscle is unstretched by any load. Arrange the apparatus so that with the screw in this position the lever is horizontal. Record a single contraction of the muscle on a rapidly revolving drum, mark the point of stimulation, and draw an abscissa. Then lower the after-loading screw until the muscle is

loaded with the whole weight, and super-impose on the same abscissa and with the same point of stimulation a contraction of the loaded muscle (Fig. 58).



FIG. 58.—Contractions of the same muscle when loaded, *A*, and when after-loaded, *B*. Actual load on muscle was 10 grms. Temp., 10° C. Magnification, 5. (A.P.B.)

The main differences between these two curves are—in the purely after-loaded muscle there is an appreciable lengthening of the latent period owing to the muscle in its unstretched condition having to take in 'slack'; a diminution in the height of the contraction, owing to the absence of tension on the muscle before the contraction began. In other words, moderate initial tension increases the power of a muscle to do work.

Progressive After-loading of a Muscle.—With the same arrangement of apparatus as in the preceding experiment, record a single con-

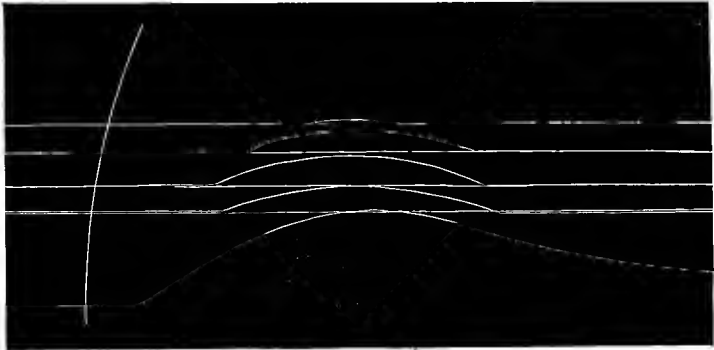

FIG. 59.—Effect of progressive after-loading of a gastrocnemius. Actual load on muscle, 4 grms. Magnification, 5. Temp., 10° C. (A.P.B.)

traction of the muscle when just after-loaded, draw a base line and mark the point of stimulation. Now raise the after-loading screw until the writing point is on a level with the highest point of the preceding curve; draw a fresh abscissa at this level and record a contraction; the point of stimulation will be the same as before. Repeat this process until the muscle can no longer lift the lever off the after-loading screw (Fig. 59).

From this experiment we see that, in a series of contractions each more after-loaded than the last, a muscle is able to undergo a little further shortening each time until it reaches its maximal shortening. Also by measuring the heights of the contractions above their respective abscissae, we learn that the longer after stimulation it is before the muscle meets the resistance of a given weight, the less is the muscle then able to overcome that resistance and raise the weight. In other words, as a muscle contracts its extensibility progressively increases, and its absolute contractile force decreases, until at the height of its contraction its extensibility is greatest and its absolute contractile force

nil. Hence a muscle would contract under the most favourable circumstances, if the load, as it was raised, progressively decreased.

Relation of Load to Work done during Contraction.—In order to record the height of contraction for a large range of weights, it is more convenient to record on a stationary drum simply the heights of a series of twitches than to super-impose a large number of curves. The apparatus is arranged for stimulating the muscle with a single maximal induction-shock, using a simple key in the primary circuit. A weight is hung near the axis of the lever of such a size that the actual load on the muscle is 50 grms.; the method of calculating this weight has been already given on p. 29. The muscle is just completely after-loaded throughout the experiment in order to get rid of the effect of alterations in the initial tension. With the lever horizontal, the muscle is stimulated, and the height of its contraction recorded on a stationary drum. The drum is rotated a short distance by hand; an additional load of 50 grms. is hung from the lever, and another contraction recorded. The process is repeated until the muscle is no longer able to raise the load off the after-loading screw. Fig. 60 gives the result of such an experiment; in it the magnification was 5, and the actual load on the muscle half of the weight hung near the axis of the lever. The following table gives in *gm. mm.* the work done by the muscle with the various loads.

Actual load in <i>gm.</i>	Actual lift in <i>mm.</i>	Work in <i>gm. mm.</i>
50	4·0	200
100	3·2	320
150	2·2	330
200	1·8	360
250	1·2	300
300	1·0	300
350	·8	280
400	·5	200
450	·4	180
500	·3	150
550	·2	110
600	·1	60
700	0	0

From the last column in this table we see that, although the height of the contractions diminishes continuously, the actual work done by the muscle increases at first rapidly and then more slowly, until it reaches its maximum with a load of 200 grms. After that point the work done begins to decrease slowly, and then more rapidly until at 700 grms. a load is reached which the muscle is unable to

lift. This weight represents the 'absolute contractile force' of this muscle, that is, the load which, brought to bear on the muscle at the instant of contraction, is just able to prevent it from shortening. Although the muscle is unable to lift this load, and therefore, when stimulated, does no visible mechanical work, it nevertheless liberates energy chiefly as heat.

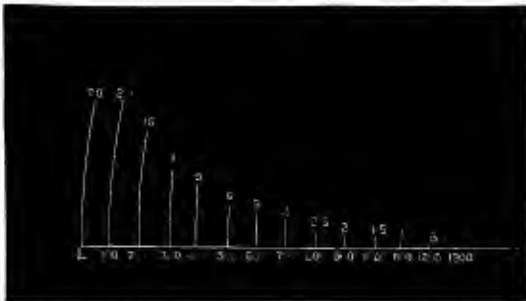

FIG. 60.—Height of contractions of gastrocnemius with increasing load. The number above each contraction is its observed height in mm. Magnification, 5. The number below each contraction is the weight in gm. hung at the axle of the lever; the actual load on the muscle was half of this number. (A.P.B.)

We are now in a position to recapitulate, so far as load is concerned, the conditions necessary to obtain an optimal contraction of a muscle and to see how far they exist in the living body. Initial tension, we have seen, decreases the latent period and increases the power of the muscle to do work. In the body the muscles are constantly loaded to a slight extent, and are thus kept stretched and free from 'slack.' In this way movements with a short latent period, and with an absence of jerkiness are obtained; and the muscles by being stretched are kept irritable, awake and fit for sudden work. On the other hand we see that a muscle, when purely after-loaded, is at a disadvantage for doing work; yet in the body the main load is thrown on as an after-load. The advantage of this arrangement depends upon the increased extensibility of contracting muscle; for, in this way liability to rupture is reduced; further, there is a saving of energy in pulling at a dead weight through an elastic spring, instead of through an inelastic cord, since some of the energy expended would be lost in a sudden jerk, but, in the case of the spring, is stored up in it and given out again as its elastic recoil. Thus smoothness is imparted to even the most sudden movements. We have

also seen that as a muscle shortens its absolute contractile force decreases; therefore, it is clear that the after-load should be thrown on to the muscle at the instant of contraction, when the contractile force of the muscle is at its maximum, and not later; this is the arrangement in the body. Further, it would be an advantage if the load decreased as the contractile force of the muscle during its contraction decreased; this is not usually the case in the body, but it does occur in certain movements, as, for instance, in jumping or when, with the upper arm horizontal, a weight in the hand is raised by flexing the forearm on the elbow.

CHAPTER XIV. (*Advanced*).

SUMMATION OF STIMULI.

In a previous chapter the subject of summation of contractions has been dealt with. This summation of 'effect' must be distinguished from the summation of stimuli, by which an inadequate stimulus, if repeated sufficiently often, becomes first adequate and then for a time increasingly effective. This is a summation of 'cause,' and probably plays an important part in the life of all living matter.

In order to demonstrate the summation of stimuli, arrange the apparatus for stimulating a gastrocnemius muscle directly with single induction-shocks, using a simple key in the primary circuit. Place the secondary coil at such a distance from the primary that the break-shocks are just subminimal. Repeat the stimulus every 5 seconds.

It will be found that sooner or later the summed excitations will cause a contraction, and, if the contractions are recorded on a slowly revolving drum, that a well-marked 'stair-case' effect is produced (Fig. 61).

In dealing with the response of muscle to two successive stimuli, it has been seen that, when the second stimulus falls within the latent period of the first, the muscle is refractory, so far as being able to



FIG. 61.—Effect of subminimal stimuli repeated every 5 seconds on gastrocnemius stimulated directly. The dots mark the points at which stimuli were sent in before they became obviously effective. Time marking in seconds. (A.P.B.)

respond with a second contraction is concerned; but it is not true that a muscle during its refractory period always entirely ignores a second stimulus.

In order to investigate this point, the apparatus is arranged as in demonstrating the effect of two successive stimuli (p. 42). The two 'striker' are placed at such an angular distance apart that the second stimulus falls well within the latent period of the first; the muscle is stimulated directly. The secondary coil is placed at such a distance from the primary that when, by rotating the drum by hand, one of the strikers is made to pass over the naked wire, a minimal or submaximal break, but no make contraction is obtained. A tuning fork is arranged to write under the myograph-lever, the drum is allowed to make one revolution at a rapid rate, a base line is drawn, and the points of stimulation corresponding to each 'striker' are marked. Swing the lever away from the drum, but do not alter the position of the base of the stand carrying the myograph. The single contraction so recorded is the response of the muscle to two break shocks. In order to determine whether the muscle has been in any way influenced by the second stimulus, raise the second 'striker,' so that it will no longer touch the naked wire, and record the contraction due to the first stimulus alone (Fig. 62). It will be found that the contraction in

response to the single stimulus is not so great as that due to the two stimuli. In other words, there has been a summation of stimuli during the refractory period. In the same way subminimal stimuli can be summated, but two maximal stimuli are summated only when they follow each other after an interval of less than $\frac{1}{500}$ th second.

As has been pointed out on p. 25, when a 'striker' passes over the naked wire, there is both a make and break of the primary circuit; consequently in these experiments the muscle really receives four induction-shocks, of which, according to the position of the secondary coil, all four might be individually subminimal, or the two break-shocks might be alone effective, or all four might be effective. In order to deal with the summation of two break-shocks alone, it is usual to perform these experiments with the following special piece of apparatus.

The Spring or Trigger Myograph (Fig. 63).—It consists of a heavy metal base which is clamped to the bench. The essential part of the apparatus is an oblong metal frame carrying a smoked glass plate, the recording surface, which is shot on two horizontal wires past the writing points. In order to prepare the apparatus for use, the frame is pulled to one side by one of the arms attached to it; this compresses a spring on the other arm, and the frame is held in position by a catch or trigger. When the catch is released the spring gives the frame and

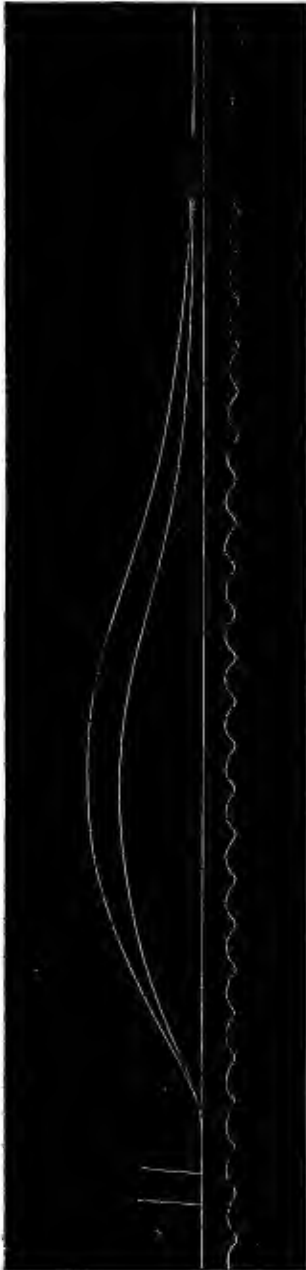

FIG. 62.—Effect of two submaximal stimuli on gastrocnemius, the second stimulus falling well within the latent period of the first. Upper curve represents the combined effect of both stimuli, the lower curve the effect of the first stimulus alone. Time marker, 100 per sec. (A.P.B.)

glass plate a rapid and uniform horizontal motion, and the momentum carries the recording surface across until stopped by the buffers at the opposite side. The frame carries on its under surface two pins which knock over two vertical keys and so breaks two primary circuits (Fig. 64). K_1 is fixed, but K_2 is movable horizontally, and its position can

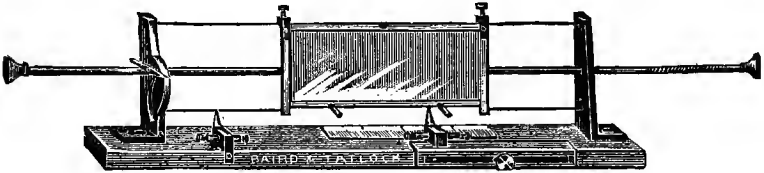

FIG. 63. —The spring myograph.

be adjusted so that it will be knocked over at any desired interval after K_1 . A pointer is attached to K_2 , and when this is opposite the zero of the scale this key will be knocked over at the same instant as K_1 ; therefore, in order that K_2 may be knocked over after K_1 and that the second

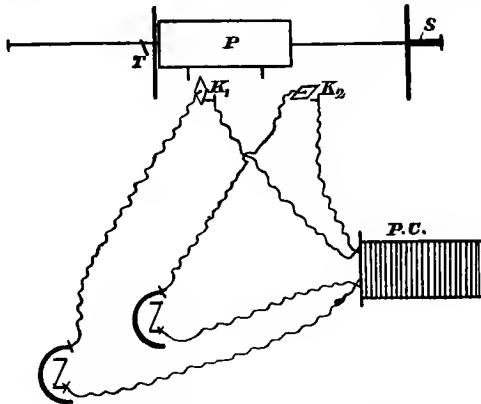

FIG. 64. —Diagram of the spring myograph in circuit.

stimulus may still fall within the latent period of the first, it is necessary to move K_2 a short distance along the scale from K_1 . Place both keys in the primary circuit of the same coil and arrange the secondary coil at such a distance from the primary as to give sub-maximal break-shocks. With the spring compressed, the catch down and both keys vertical, the writing points of the lever and tuning fork are placed against the recording surface at its spring end in order that the whole contraction may be recorded. Release the catch. The frame is then pulled back to its original position, both keys are made vertical

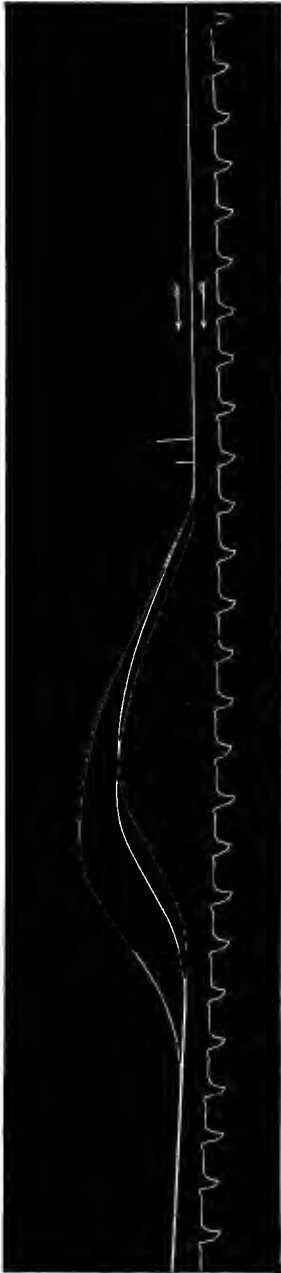

FIG. 65.—The effect of two stimuli upon the gastrocnemius muscle. The vertical lines show the moments of stimulation; the arrows indicate that the induction shocks were in the same direction. The uppermost curve represents the combined effect of both stimuli; the other curves the effect of the separate stimuli. Time marker, 100 per second. The curves, which were taken with the Pendulum Myograph, should be read from right to left. (M.S.P.)

again, and the pins on the frame are slowly brought up against the two keys in turn and the points along the curve marked at which the two stimuli entered the muscle; the second stimulus should have fallen well within the latent period of the first. Reset the apparatus, leaving K_2 horizontal, but placing K_1 vertical, and record the contraction due to the first stimulus alone. This second contraction will be found to be smaller than that caused by the summation of the two sub-maximal stimuli.

Fig. 65 shows the contractions obtained by a Pendulum Myograph which is fundamentally the same as a spring myograph, and differs only in that the smoked plate, instead of being shot horizontally across by a spring, swings across at the end of a long and heavy pendulum and describes an arc of a circle.

The glass plate in either case is varnished in the ordinary way, and, when dry the curves are reproduced by exposing to daylight sensitive paper covered by the smoked plate.

CHAPTER XV. (*Advanced*).EFFECT OF DISTILLED WATER AND OF VARIOUS SALTS
ON MUSCLE.

THE various tissues of the body are all bathed in the same fluid, the lymph, which so far as the water and salts it contains are concerned, has a uniform composition. The tissues, although immersed in the same fluid, show different and characteristic properties owing to their difference in structure and chemical composition. If, however, the composition of the fluid, in which any given tissue is immersed, be altered, the composition and consequently the properties of its protoplasm must also be altered. The first effect on living matter of such a change is to cause its stimulation, and then if the change be sufficiently profound and long-continued to produce its death.

Only two changes in the tissue fluids will be considered here, namely—(a) Gross change in the osmotic pressure of the fluid, by using distilled water or a strong saline solution; and (b) Change in the ions in solution without alteration in the osmotic pressure of the fluid, by using solutions of various salts isotonic with frog's blood-plasma.

Effect of Distilled Water.—Dissect out a gastrocnemius muscle and place it, without a 'trouser' of skin, in a watch-glass containing distilled water. For a few minutes the muscle may show irregular contractions, then it becomes opaque, swollen and incapable of responding to a stimulus with a contraction. The muscle is said to have passed into a condition of 'water-rigor.' Test the muscle with induction shocks and demonstrate that it will no longer contract.

By placing the muscle into distilled water two effects are produced—the inorganic salts in the muscle diffuse out into the water, and water is attracted by osmosis into the muscle so that each fibre becomes greatly distended with fluid. The first effect of these changes is to produce stimulation, but, as the muscle fibres are distended with fluid, they become incapable of contracting, and finally there are not enough salts left in the muscle to keep the globulins in solution; hence the muscle becomes gradually opaque and dies.

Effect of Strong Saline Solutions.—This effect will be exactly the opposite of that due to distilled water; for water will be abstracted from the tissue, and large quantities of the salt will diffuse into the muscle.

The effect on a tissue of mere abstraction of water from it is best seen by allowing a nerve to dry. Make a gastrocnemius and sciatic

preparation, keep the muscle and lower half of the nerve just moist with tap-water saline, but allow the upper half of the nerve to dry. As the nerve begins to dry, irregular contractions of the muscle come on which are stopped by moistening the nerve; showing that loss of water acts as a stimulus to nerve. If the drying is allowed to continue, the dry portion loses its irritability and dies.

Now place upon the muscle a few crystals of NaCl; irregular contractions will soon appear. These are partly due to the abstraction of water, but also, as we shall see in the next experiments, to the stimulatory effect of NaCl.

The above experiments show that, in order to keep muscles and nerves irritable and in good condition, they must be moistened with a fluid which will neither give up nor abstract water from the tissue, *i.e.* which is isotonic with the animal's lymph. For this purpose a .7 per cent. solution of NaCl in distilled water has frequently been used. This solution, although isotonic with frog's blood, does not contain the calcium and potassium salts found in blood-plasma and lymph; and the question arises whether this alteration of the ions in solution affects in any way the properties of muscle.

In order to investigate this point, prepare two sartorius preparations with their bony attachments and without injury to their muscular fibres. Place one muscle in Biedermann's solution (.5 grms. NaCl, .2 grms. Na_2HPO_4 , 2.04 grms. Na_2CO_3 in 100 c.c. distilled water), and the other in .7 per cent. NaCl in distilled water.

The muscle in Biedermann's solution, especially if the solution be cool (3° — 10° C.), will after a shorter or longer interval begin to show fibrillary twitches and may even contract regularly and rhythmically as a whole. As soon as the result has been obtained, transfer the muscle to a solution made by adding to 100 c.c. of .7 per cent. NaCl solution in distilled water, 10 c.c. of a saturated solution of CaSO_4 , or of a 10 per cent. solution of CaCl_2 in distilled water. The spontaneous contractions will soon cease.

The other muscle placed in the pure NaCl solution may remain quiescent; very often it will show fibrillary twitchings and irregular contractions, which are rapidly stopped by transferring the muscle to the solution containing a calcium salt as well as NaCl. Should the muscle, however, remain perfectly quiescent¹ it can still be shown that it is no longer in a perfectly normal condition. After it has remained in the solution for half an hour, remove it and connect it

¹Frog's muscle differs somewhat in its behaviour in any given solution according to the time of year, there being a marked difference between muscle in the autumn and spring.

to a myograph lever and stimulate it with a single maximal break shock. The contraction recorded on the drum will be no longer an ordinary single contraction, but a series of tetanic twitches of abnormal height and duration. Now remove the muscle, immerse it for ten minutes in the solution containing the added calcium salt, and again record its response to the same stimulus. A normal single contraction will be obtained. It is clear that sodium salts, when acting alone on skeletal muscle, have a powerful stimulatory effect, and that this can be neutralised by adding a certain proportion of calcium salt. For this reason 'normal' saline solution is always made with tap-water instead of with distilled water. Some tap-waters, however, do not contain nearly enough calcium to bring about complete neutralisation of the sodium salt.

From the above experiments we learn certain facts of considerable practical importance. We see that tissues are greatly affected by changes in the osmotic pressure of the fluid surrounding them. Care must therefore be taken not to expose the tissues of an animal or man to fluids which are not isotonic with the blood-plasma. In man the solution of NaCl isotonic with the blood-plasma is only just under 1 per cent., and therefore differs widely in strength from the solution for a frog; it is very necessary to bear this in mind when injecting fluid into veins or under the skin, and when irrigating the peritoneal cavity during operations. We further see that, when isotonic solutions of electrolytes are used, the tissues are by no means indifferent to the ions in solution. A really 'normal' saline solution would, therefore, be one which contained the same salts in the same proportion as the animal's own blood-plasma. Ringer's¹ fluid is an attempt to make such a solution for the frog. Since in man it would often be difficult to obtain such a solution when wanted, it might be preferable, instead of using an imperfectly 'normal' saline solution, to use an isotonic solution of a non-conductor, such as dextrose. A 5·8 per cent. solution of dextrose is isotonic with human blood-plasma.

In all the above experiments it has been found that skeletal muscle responds to the abnormal constant stimulus by an activity which is not constant, but intermittent or rhythmical. This raises the question whether the rhythmical contraction of the heart may not be the normal response of that particular kind of muscle to the constant chemical stimulus of the blood-plasma, and the same might be also partly true of the rhythmical activity of the respiratory and vasomotor centres.

¹ A modified Ringer's solution contains NaCl ·7 per cent., CaCl₂ ·0026 per cent., and KCl ·035 per cent.

CHAPTER XVI. (*Advanced*).FATIGUE OF A VOLUNTARY MOVEMENT AND OF A MUSCLE-
NERVE PREPARATION WITH ITS CIRCULATION INTACT.

WHEN a voluntary movement is repeated sufficiently often fatigue is produced. The seat of this fatigue has to be investigated; it might be in some part of a neurone in the central nervous system, or in some part of the peripheral nerve and muscle: in other words, the fatigue might be primarily central or peripheral. As the result of certain ergographic experiments it has been answered that this fatigue is of central origin. The experiments consisted in lifting a heavy weight suspended over a pulley by flexing a finger and registering the height of each successive lift. When the movement had been repeated until the muscle was no longer able to lift the weight at all, it was found that electrical stimulation of either the nerve supplying the muscle or of the muscle itself caused the weight to be again lifted, but to a less height than before. When the electrical stimulation had in turn fatigued the movement it was found that a voluntary contraction of the muscle was again able to lift the weight, owing, it was supposed, to the resting of the cells in the central nervous system. From these experiments it was argued that the fatigue of a voluntary movement is purely central.

The methods used in the above experiments are open to grave objections, and it is necessary to touch upon some of these in order to avoid them. The use of a heavy weight is open to the objection that the muscle, when no longer able to lift that weight, is still capable of contracting, and could well lift a lighter weight; therefore, it is better to make the muscle bend or pull on a spring, which will enable the feeblest as well as the strongest pull exerted by the muscle to be recorded. Again, electrical stimulation of a nerve or a muscle can be a much more powerful stimulus than that resulting from the maximal discharge of a motor nerve-cell; consequently the fact that peripheral stimulation can make the muscle again lift the weight after voluntary impulses fail, is no proof that the fatigue was central. Further, when a nerve or muscle is stimulated by electrodes placed upon the skin, it is impossible to produce equal stimulation of all fibres; some muscle-fibres will receive a maximal and others only a sub-maximal or minimal stimulus, and the pull of the muscle as a whole will be equivalent to that of a weaker muscle. When the muscle appears to be fatigued by peripheral stimulation, then a return to volitional stimulation, by pro-

ducing equal stimulation of every fibre, leads to an apparent recovery of voluntary power. In this way is to be explained the apparent paradox, that a muscle fatigued by either voluntary or peripheral stimulation shows a recovery of power when stimulated in the opposite way.

In order to investigate this subject we shall compare the curve of voluntary fatigue taken with a spring ergograph from the human abductor indicis, with the curve obtained from the frog's gastrocnemius, with its circulation intact and stimulated through the sciatic nerve.

The Spring Ergograph.—A simple form of this instrument is shown in Fig. 66 to consist of a rigid upright iron bar which is clamped to

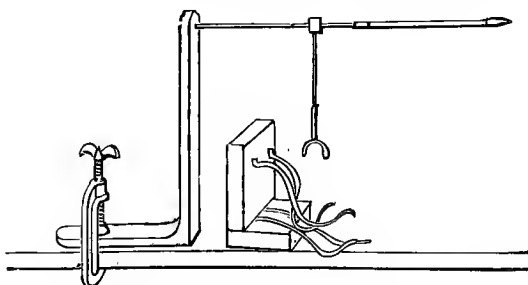

FIG. 66.—Spring ergograph. (Porter.)

the table. From the upper end of this projects a horizontal straight steel spring, the free end of which carries an ordinary writing point. The spring carries on its under side a short vertical steel arm, the lower end of which fits over the distal end of the second phalanx of the index finger. When the abductor indicis contracts the spring is pushed up; by sliding the vertical arm along the spring the magnification of the movement and the strength of the spring can be altered. The hand is placed along the vertical side of the wooden support and the three outer fingers tied to it, leaving the thumb and index finger free. The forearm should be fixed to the bench in some form of support, but care must be taken not to tie down the arm sufficiently tightly to interfere with its circulation.

The subject of the experiment should sit comfortably and with his eyes shut, should not be spoken to nor in any way have his attention diverted, but should confine himself to giving a maximal contraction of his muscle every time he hears the beat of a metronome, which is set to give a beat every second. The observer takes the time of the experiment in minutes and so calculates the number of contractions recorded, further he has to see that the vertical arm does not slip

out of position along the finger. In this way take 300 to 600 contractions on a drum revolving at an extremely low rate (Fig. 67).

At first sight the most striking feature of the curve is the more or less rhythmical waxing and waning in the height of the contractions; this seems to be purely central in origin and to be due to variations in the strength of the voluntary impulse communicated to the muscle. Practice to a large extent does away with this rhythm. When the height of the contraction is measured it will be found that the average height decreases during the first 180 contractions and then attains a fairly constant level, which represents about 85 per cent. of the height of the original contractions. The initial decrease is better marked in Fig. 68, and here the fatigue-level was only about 45 per cent. of the original height. The characteristics of an ergographic fatigue-curve, therefore, are an initial fall which takes place during a variable number of contractions, and the attainment of a fairly constant level, which represents varying percentages of the height of the original contractions. This curve strongly suggests that during a series of contractions two processes are at work; one by which available combustible material is being used up and the products of katabolism are accumulating, and the other by which both these defects are made good by the circulation. During the early part of the curve the first process preponderates over the second and the height of the contraction decreases, but as soon as the two processes exactly balance each other a uniform level is maintained for hundreds of contractions. The probable seat of these processes will be referred to after the next experiment has been performed.

In order to obtain a record of the contractions of the gastrocnemius with its circulation intact, arrange the apparatus for stimulating the sciatic nerve with maximal induction shocks, using a simple key in the primary circuit. The cerebrum of the frog must be destroyed and the muscle-nerve preparation made without causing bleeding. The cerebral hemispheres are destroyed by compression, leaving the medulla and spinal cord intact, and the gastrocnemius is prepared in the usual way. A string ligature is placed beneath the gastrocnemius and tied tightly round the upper part of the tibio-fibula and the remaining muscles; the leg is then cut through below the ligature. The whole frog is placed belly downwards on the myograph-board, a strong pin is pushed through the lower end of the femur and driven firmly into the cork. A piece of moistened flannel is then pinned down over the trunk to prevent the contractions of the muscles of the trunk from disturbing the lever connected with gastrocnemius. The skin over the middle of the thigh is divided longitudinally for a short distance, the muscles carefully

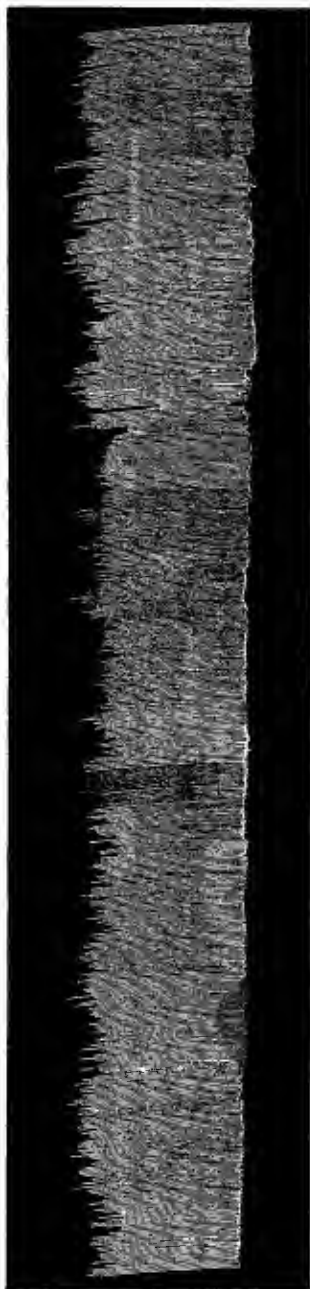

FIG. 67.—Ergographic tracing of abductor indicis taken with a spring ergograph. The tracing is to be read from right to left and represents 600 contractions performed at the rate of one per sec. (A.P.B.)



FIG. 68.—Ergographic tracing of abductor indicis of an ill-nourished boy. The tracing is to be read from right to left and represents 150 contractions performed at the rate of one every 2 secs. (A.P.B.)

separated and the sciatic nerve exposed and freed ; the nerve is gently raised by slipping a thread beneath it and the electrodes, insulated



FIG. 69. — Exhaustion curve of gastrocnemius with its circulation intact. Muscle was just after-loaded and was stimulated indirectly once every 5 seconds. This part of curve extended over a period of 45 minutes and was broken off temporarily owing to the frog moving. (M.S.P.)



FIG. 70. — Continuation of same experiment, extending over a period of 15 minutes. (M.S.P.)

from the underlying muscles by a small piece of cork, are placed beneath the nerve. It is essential that the nerve should not be injured and



Fig. 71.—Continuation of same experiment, after the leg had been cut off. The whole curve represents a period of about 40 minutes. (M.S.P.)



Fig. 72.—Exhaustion curve of gastrocnemius just after-loaded and stimulated once every 5 secs. indirectly. First part of curve represents 15 minutes, then follow 5 minutes' rest and a short recovery curve. After another 7 minutes' rest a further recovery curve is shown with the muscle loaded instead of after-loaded. (M.S.P.)

should be kept properly moistened throughout the experiment. The muscle is suitably weighted and just after-loaded. The nerve is stimulated by a maximal shock every 5 secs., and the contractions recorded on a drum revolving at the slowest possible rate (Figs. 69, 70).

It will be seen that the height of the contractions, although increasing at first, gradually falls off until at the end of about 200 contractions it reaches a uniform level, which represents about 85 per cent. of the original height and was then maintained with scarcely any alteration for three-quarters of an hour. This curve, therefore, is identical in general form with that obtained by the ergograph. Here again we see an initial fall and then a constant level of contraction, representing probably the equilibrium between two opposite processes, which must in this case be affecting some part of the peripheral nerve and muscle. The actual seat of this peripheral change is not absolutely certain (see further Expts. in Chapter XXII.).

Now cut through the leg in the middle of the thigh, so as to destroy the circulation through the gastrocnemius and continue the stimulation (Fig. 71). It will be seen that the height of the contractions rapidly and continuously decreases, and that at the end of about 320 contractions the muscle is no longer able to lift the lever off the after-loading screw.

CHAPTER XVII. (*Advanced*).

THE RATE OF TRANSMISSION OF A NERVOUS IMPULSE.

THE rate at which an impulse is transmitted along a nerve is important because it throws some light upon the nature of the impulse. It travels much more slowly than an ordinary electric current, and, although it is accompanied by an electric change, it is something more complex. Its rate of propagation is 27 metres per second ($88\frac{1}{2}$ feet per sec.) in the frog's sciatic nerve, and 60 metres per second (196 feet per sec.) in the motor nerves of man.

(a) **In the Motor Nerves of the Frog.**—The following experiment should be performed for the determination of the velocity of the nervous impulse in the sciatic nerve of a frog :

A recording drum is arranged with a 'striker' for completing the circuit of the primary current of the induction-coil. To the secondary coil are attached two Du Bois keys in the manner shown in the diagram (Fig. 73); from these pass two pairs of electrodes, one of which will be applied to the upper portion of the nerve, the other to the lower

portion. The entire length of the sciatic nerve is dissected out, and the gastrocnemius muscle is connected with the lever of a myograph; the drum is arranged for rapid revolution, and a maximal shock is to be used for excitation. The latency of the muscular contraction (Chapter III., p. 22) is then determined, first for stimulation by the upper pair of electrodes, the lower pair being short-circuited by closure of its Du Bois

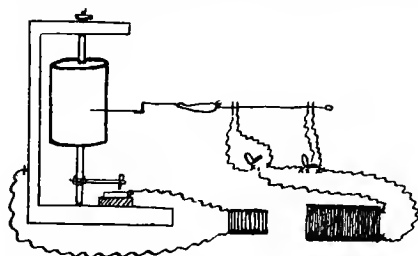

FIG. 73.—Diagram of the experiment on the rate of transmission of a nervous impulse.

key; then the experiment is made with the lower pair of electrodes for the exciting point. The time of this latency is determined by recording underneath the curves the vibrations of a tuning fork with 100 vibrations per second; the difference in time between the moment of stimulation and the resulting contraction in the two cases represents the time taken for the nervous impulse to pass along the length of nerve between the two pairs of electrodes (Fig. 73). This piece of nerve is measured in millimetres,¹ and then the velocity of the transmission of the nervous impulse is calculated.

For the accurate determination of the rate of propagation of a nervous impulse a very rapid rate of movement of the recording surface is required; for this reason the spring-myograph (Fig. 63, p. 65) or the pendulum-myograph may be used with advantage in the place of the drum.

(b) **In the Motor Nerves of Man.**—The velocity of the transmission of a nervous impulse in the motor nerves of man can be determined in the following way: A thick-walled india-rubber ball, similar to that used with a photographic 'shutter,' is connected with a recording tambour. Two clinical electrodes are moistened with strong saline solution in order to improve their conduction and contact with the skin; the large flat electrode is fastened to the leg of the subject, and the small electrode placed above the clavicle will be pressed over the brachial nerves. These electrodes are connected with the secondary

¹ There is a millimetre scale upon the slide of the induction-coil.

coil of an inductorium, and in the primary circuit is interposed the 'trigger' key of the spring-myograph.

The india-rubber ball is held between the middle finger and the thumb, and the contraction of the flexor muscles will be recorded by the lever of the tambour, when the nerve is excited. The moment of stimulation is determined in the usual way (p. 25), and then the experiment is again performed, but with the small electrode pressed over the median nerve at the bend of the elbow. The moment of stimulation is again determined, in order to show that the resting position of the point of the lever has not been changed. The difference between the latency in the two contractions is measured by a tuning-fork vibrating 100 times per second, and the length of nerve between the two points of stimulation is estimated; from these data the rate of transmission of the nervous impulse can be calculated.

CHAPTER XVIII. (*Advanced*).

THE POLARISATION OF ELECTRODES AND UNPOLARISABLE ELECTRODES.

Polarisation of Electrodes.—Ordinary metal electrodes in contact with a muscle or nerve will be surrounded by lymph, and in this fluid electrolysis will take place during the passage of an electric current. The ions resulting from this electrolysis will be positive and negative respectively; if, therefore, the circuit of this seat of chemical and electrical change be suddenly made or broken, a shock will be produced, for the wires of the electrodes surrounded by the electrolysed fluid will form a minute battery. This can be demonstrated by the following experiment: A pair of electrodes, connected with a Du Bois key, is placed under the sciatic nerve, which has been exposed in the thigh of a pithed frog. Making or breaking the circuit causes no contraction. The two wires of a Daniell battery are connected with each side of the Du Bois key, and the current is allowed to pass through the nerve for several seconds. Then these two wires are rapidly disconnected from the battery and key; the key is closed and opened, and each time a contraction of the muscles of the leg is caused. This make and break can be repeated several times with a similar result, until the polarisation has disappeared.

This experiment shows the necessity of unpolarisable electrodes in experiments upon the effects produced in nerve and muscle by the

passage of a constant electric current, and also the necessity of using a Du Bois key as a bridge to short-circuit the electrodes.

Unpolarisable Electrodes.—The preceding experiment has shown that the electrolysis occurring around the ordinary metal electrodes may easily act as an exciting electric current, and thus cause errors in experiments. In order to avoid this unpolarisable electrodes are used. The electric current from the battery is conducted through media which are not liable to polarisation.

The structure of Burdon-Sanderson's electrodes is shown in the following diagram (Fig. 74). A smooth amalgamated zinc rod dips into a saturated solution of zinc sulphate, which in turn conducts the current by means of a plug of kaolin or china clay, made into a thick paste with normal saline solution (.75 per cent. sodium chloride). The plug rests upon a small glass tube with a flange; this delays the spread of the zinc sulphate into the kaolin. The nerve or muscle can be placed in contact with the plug of kaolin, or may be connected thereto by threads saturated with normal saline solution and kaolin. The plug must be kept moist with normal saline solution, for the electrodes have a high resistance.

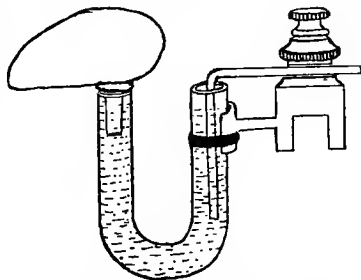

FIG. 74.—Unpolarisable electrode. Burdon-Sanderson's pattern.

The electrodes must be set up with clean hands and material, otherwise polarisation will occur. The solution of zinc sulphate must not be allowed to touch the tissue, for chemical excitation would occur. Kaolin and normal saline solution do not stimulate muscle and nerve.

The previous experiment on the polarisation of electrodes should be repeated with the unpolarisable electrodes. The result will be negative if the electrodes have been well and truly made.

CHAPTER XIX. (*Advanced*).

TRANSMISSION OF A NERVOUS IMPULSE IN BOTH DIRECTIONS.

THE excitatory state produced by stimulation of a nerve can be transmitted in both directions. This can be shown by the following experiments.

Sartorius Experiment.—The sartorius muscle is dissected out and its

iliac end is divided into two portions (Fig. 75). Stimulation with a weak induction shock at (*a*) or (*a'*), when there are no nerve-fibres, will produce a contraction of the one half of the muscle. Excitation, however, at (*b*) or (*b'*), where there are nerves, will evoke a contraction of both halves

Gracilis Experiment.—The gracilis muscle of the frog is in two portions completely separated by a tendinous intersection (Figs. 21, 76). Both halves of the muscle are supplied by a single nerve, the individual

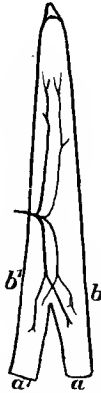

FIG. 75.—Diagram of the sartorius experiment to show the transmission of a nervous impulse in both directions.



FIG. 76.—Diagram of the gracilis experiment to show the transmission of a nervous impulse in both directions.

fibres of which divide and supply both halves of the muscle. Stimulation of any kind at (*a*) or (*a'*) where there are no nerve-fibres causes only the corresponding half of the muscle to contract; but excitation at (*b*) or (*b'*), where the nerves lie, will cause both halves to contract.

CHAPTER XX. (*Advanced*).

THE RELATION BETWEEN MUSCLE AND NERVE. THE INDEPENDENT EXCITABILITY OF MUSCLE.

IN addition to the experiments which have been described in the elementary course (page 48), the following experiment upon the sartorius muscle should be performed.

The sartorius muscle lies on the ventral surface of the thigh (Fig. 21),

and its outlines can be made distinct by sponging it with the frog's heart full of blood. The muscle is carefully dissected out and will contract when its nerve, which passes into the muscle at the middle of its inner border, is cut across by the scissors. If the muscle be placed between two glass-slides and examined under a microscope, the distribution of its nerve can be seen to resemble that shown in the diagram (Fig. 77). The finer branches of the nerves and even the end-plates can be more readily seen if the muscle be treated with acetic acid. There are no nerves in the terminal portions of this muscle, which consists of fibres running in a direction parallel with its length.

The sartorius muscle is dissected from the other thigh and the nerveless parts are stimulated by a pinch with a pair of forceps or by an electrical shock; they contract, the muscle possesses independent excitability.

The absence of nerves from the terminal portions can also be shown in the following way. The muscle is suspended from its tibial end and is lowered until the cut iliac end touches some strong glycerine contained in a watch-glass; it does not contract. A thin transverse slice is cut away and the muscle is again lowered into contact with the glycerine; there is still no contraction. This procedure is repeated until the nerves are cut across and on contact with the glycerine are stimulated and make the muscle pass into a contracted condition.



FIG. 77. — Diagram of the sartorius muscle to show the distribution of its nerves.

CHAPTER XXI. (*Advanced*).

THE EFFECT OF A CONSTANT ELECTRICAL CURRENT UPON THE EXCITABILITY AND CONDUCTIVITY OF NERVE.

THE passage of a constant current produces changes in the excitability of nerve, at the anode there is a condition known as **anelectrotonus**, the excitability is diminished; at the kathode there is an increase in excitability, a state of **katelectrotonus**. The conductivity is also affected, there is a fall in both the anodic and cathodic regions. These effects can be shown by the following experiment.

One Daniell battery is connected by two wires with a Pohl's reverser whereby the direction of the current can be changed; from the reverser the wires pass by means of a Du Bois key to a pair of unpolarisable electrodes. This is the polarising circuit. The stimulating circuit is set up separately for the production of single induction-shocks (Fig. 78). A preparation of the sciatic nerve and gastrocnemius muscle is carefully made from a recently pithed frog, and is placed in a moist chamber; a pin is fixed through the lower extremity of the femur, and the tendo Achillis is connected by a thread with a lever.

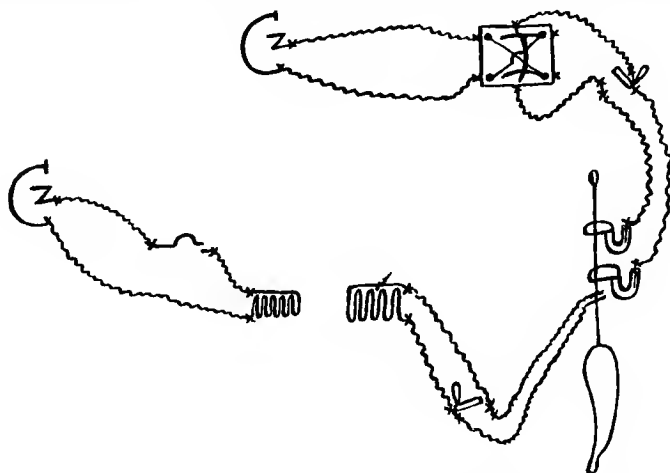

FIG. 78. —Diagram of the experiment on the effects of a constant electrical current upon the excitability and conductivity of nerve.

The sciatic nerve is placed across the kaolin plugs of the unpolarisable electrodes. The drum can be moved by hand. A minimal stimulus for the nerve is obtained, care being taken to use only the break or make-shock. The minimal contraction is recorded on the stationary drum.

The current from the polarising circuit is closed in an ascending direction, so that the current enters the nerve on the side near the muscle and immediately above the stimulating electrodes, which are connected with the inductorium. The nerve around the point of entry or anode of the polarising current is depressed in its excitability, and the application of a minimal, or even stronger, stimulus is no longer effective (Fig. 79). The polarising current is short-circuited by the Du Bois key, and by means of the reverser is changed in its direction, so that on opening the Du Bois key the current is descending, and the area of nerve near the stimulating electrodes passes into a condition of

katelectrotonus. The minimal stimuli now become maximal, owing to the increase in the excitability of the nerve at the kathode.

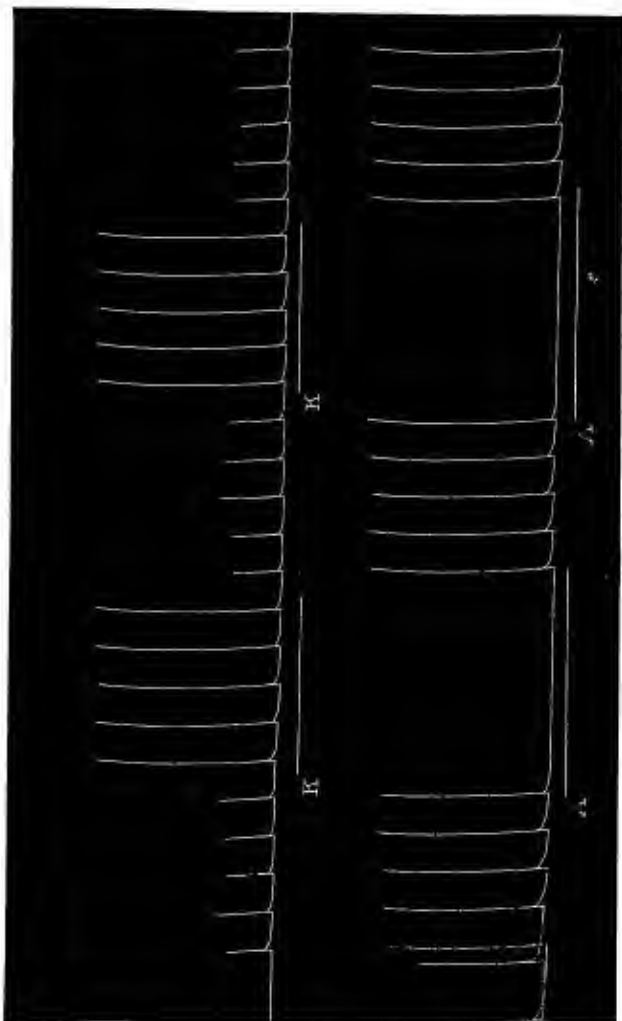

FIG. 70.—The effect of a constant electrical current upon the excitability of nerve. (1) The nerve was stimulated at regular intervals by single induction shocks almost strong enough to produce a maximal contraction. The horizontal lines marked A show the time during which the polarising current was closed in an ascending direction, that is the duration of anelectrotonus; the single induction shocks were no longer effective. (2) The nerve was stimulated at regular intervals by minimal induction shocks. The horizontal lines marked K show the time during which the polarising current was closed in a descending direction, that is the duration of katelectrotonus around the exciting electrodes; the minimal shocks become maximal. The curves should be read from left to right. (M.S.P.)

The above experiments can be repeated with a crystal of common salt placed in the position of the stimulating electrodes. The salt causes chemical excitation, and the muscle shows incomplete tetanus, which is quelled by anelectrotonus, and augmented by katelectrotonus (Figs. 81, 82).

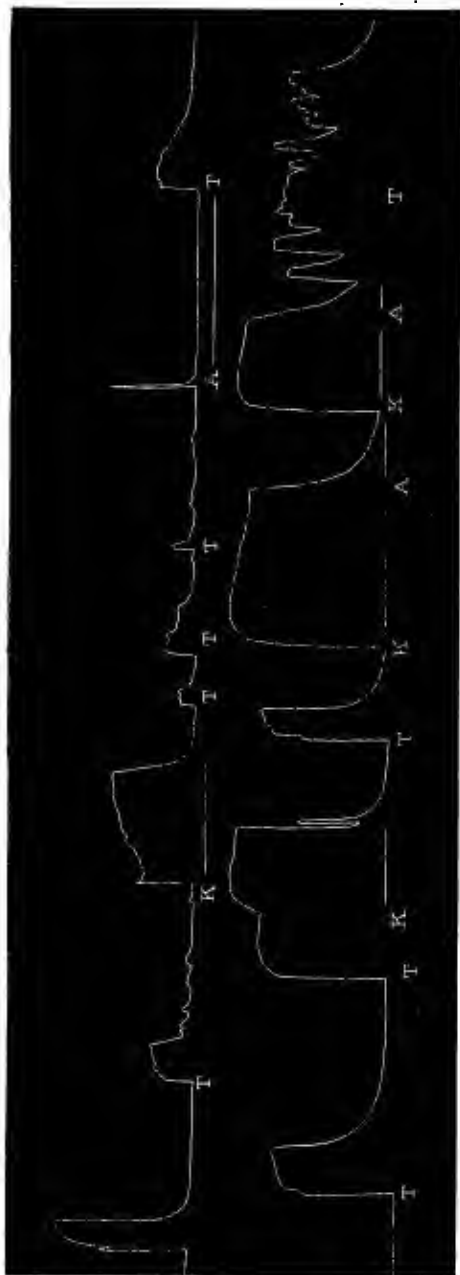

FIG. 80.—The effect of a constant electrical current upon the excitability of nerve. The nerve was stimulated by weak tetanizing shocks obtained with Helmholtz's arrangement; the incomplete tetanus *T* was recorded. The production of a condition of katelectrotonus, *K*—, increased the effect of the stimuli and thus augmented the tetanus. The production of a condition of analectrotonus, *A*—, around the exciting electrodes abolished the effect of the stimuli; the excitability of the nerve was diminished, the tetanus ceased. The curves should be read from left to right. The tracing has been reduced in size. (M.S.P.)



FIG. 81.—The effect of a constant electrical current upon the excitability of nerve. A crystal of common salt was employed for the stimulation of the nerve; the chemical stimuli were subminimal, but became effective directly the crystal of salt was thrown into a condition of katelectrotonus, K—, the chemical stimulation of the nerve caused incomplete tetanus of the muscle. The curve, which has been slightly reduced in size, should be read from left to right. (M.S.P.)

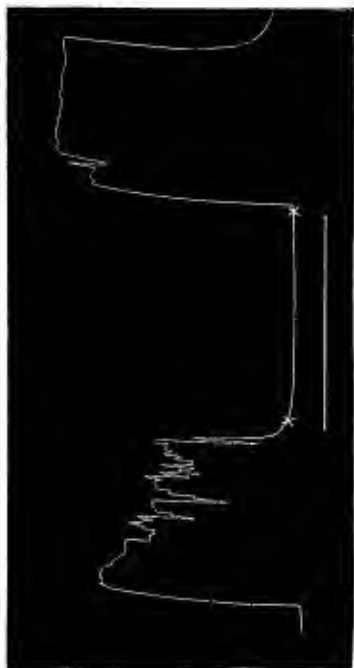

FIG. 82.—The effect of a constant electrical current upon the excitability of nerve. This tracing is a continuation of that in FIG. 81. The chemical stimulation of the nerve from the penetration of the salt produced incomplete tetanus, which could be abolished or quelled by throwing the stimulated portion of the nerve into a condition of anelectrotonus. The beginning, duration and end of the stage of anelectrotonus are indicated by the stars and horizontal line. The curve should be read from left to right. (M.S.P.)

The conditions of anelectrotonus and of katelectrotonus spread on each side of the respective electrodes, so that between the poles there is a decrease in excitability near the anode, an increase of excitability near the kathode, and no alteration in excitability at a point about midway between the poles. These changes in the interpolar region are best studied by means of a mechanical stimulus, such as Tigerstedt's hammer, which is worked by an electromagnet. The results of such an experiment are shown in Fig. 83.



FIG. 83.—The effect of a constant electrical current upon the excitability of nerve in the interpolar region. I. The stimuli produced by the vibrating hammer were applied at the *middle point* between the polarizing electrodes. The moment of closure of the constant current is shown by the big contraction, its duration by the horizontal line and stars, and its direction, ascending or descending as the case may be, by arrows. The contractions are practically equal whether there is or is not a polarizing current present; the excitability of the middle point is unchanged. II. The vibrating hammer was applied in the interpolar region but near the electrode, anelectrotonus A was produced, the stimuli became subminimal; then katelectrotonus K was produced, the effectiveness of the original stimuli was increased. The moment of closure of the constant current is shown by the big contraction, its duration by the horizontal line and stars. The curves, which have been reduced to one half the original size, should be read from left to right. (M. S. P.)

The effect of the constant current upon the conductivity of the nerve is determined upon the same preparation. The stimulating electrodes are placed upon the central part of the nerve; a minimal stimulus is found, and its effect is recorded upon the stationary drum. The polarising circuit is now closed through the nerve in either the ascending or descending direction, and then the minimal stimulus is again applied. It is no longer effective owing to the decrease in the conductivity of the nerve. This change in the conductivity of nerve is also shown in the experiment upon the absence of fatigue in a stimulated nerve (Chapter XXII)

CHAPTER XXII. (*Advanced*).

THE ABSENCE OF FATIGUE IN A STIMULATED NERVE.

NERVES are not subject to fatigue, even if they be repeatedly stimulated for long periods of time. The following experiment not only demonstrates this fact, but at the same time shows that the passage of a constant electrical current through a portion of a nerve blocks the transmission of the excitatory state which is produced in the nerve by a stimulus applied above the polarising electrodes (page 86).

An induction coil is arranged for faradic shocks, and a pair of unpolarisable electrodes are connected by a Du Bois key with a Daniell cell. The two sciatic nerves of a pithed frog are dissected up to their points of exit from the vertebral column, which is then cut across above the nerves. The thighs are cut away above the knee, and the two legs with their nerves are placed in a moist chamber, and are fixed by pins pushed through the lower extremities of the femora. The stimulating electrodes, which are connected with the secondary coil by means of a

Du Bois key, are placed under both sciatic nerves ; the unpolarisable electrodes are placed under one sciatic nerve midway between the muscle and the stimulating electrodes. The induction shocks are now allowed to pass through both nerves for a few seconds ; the muscles of both legs are thrown into tetanus. The stimulation is stopped and the polarising current is passed through the one sciatic nerve. The faradisation of both nerves is again commenced ; the muscle in the one case will be sent into tetanus and quickly fatigued, but the other muscle shows no contraction, for the polarising current passing through its nerve blocks the passage of the nervous impulses evoked by the stimulating electrodes. When the first muscle is fatigued the polarising current should be broken ; the block is removed from the course of the sciatic nerve of the other muscle, which is at once tetanised by the stimulation of its nerve.

CHAPTER XXIII. (*Advanced*).

THE ELECTROMOTIVE PROPERTIES OF MUSCLE AND NERVE.

THREE simple experiments upon the electromotive properties of muscle have already been described (page 51). The following experiments require more care and very excitable tissues.

Secondary Twitch from the Heart.—If a freshly prepared and very excitable nerve be laid upon the heart of a frog,¹ so that the cut end of the nerve is on the base and the longitudinal surface upon the apex of the ventricle, a twitch of the muscle connected with the nerve is observed at each contraction of the ventricle. Each time the muscle-fibres of the ventricle contract, a “*current of action*” is produced and stimulates the nerve

A fine glass rod should be placed under the middle portion of the

¹For these preparations the frogs should have been kept cold for some time before the experiment.

length of nerve, which lies on the ventricle, so that the current may not be short circuited.



FIG. 84.—Diagram of the experiment to show the stimulation of a muscle by the "current of action" of another muscle.

Stimulation of a Muscle by the "Current of Action" of another Muscle.—The sartorius muscle is very carefully dissected on each side, and then the one muscle is placed overlapping the other; the contact of the two muscles is secured by gentle pressure with two pieces of cork (Fig. 84). Stimulation of one muscle will produce a contraction in both; the "*current of action*" in the first stimulates the second muscle.

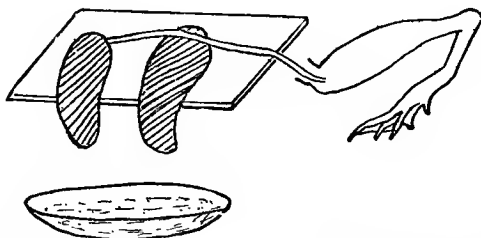

FIG. 85.—Diagram of the experiment to show the stimulation of a nerve by its own "current of injury."

Stimulation of a Nerve by its own "Current of Injury."—Two plugs of kaolin moistened with normal saline solution are placed upon a piece of glass, and the tails of the plugs are made to hang over the edge (Fig. 85). The sciatic nerve of a pithed frog¹ is carefully dissected down to the knee, the thigh is cut across, but the leg and foot are left intact. The nerve is so placed that its cut surface is upon one plug and its longitudinal surface upon the other plug. A watch-glass filled with strong saline solution, which is a good conductor of electricity, is suddenly brought in contact with the ends of the kaolin plugs; thus the circuit is suddenly made and can be suddenly broken by the removal of the watch-glass. If the preparation be very excitable, a twitch is observed at each make and

¹For these preparations the frogs should have been kept cold for some time before the experiment.

break of the circuit; the nerve is stimulated when the circuit of its "current of injury" is completed or broken.

CHAPTER XXIV. (*Advanced*).

THE ELECTROMOTIVE PROPERTIES OF MUSCLE AND NERVE— CONTINUED. THE GALVANOMETER AND THE CAPILLARY ELECTROMETER.

DEMONSTRATIONS.—The galvanometer and the capillary electrometer are delicate instruments which are easily damaged; they are employed to investigate the electromotive properties of muscle and nerve. The essential experiments upon that subject have already been performed by means of the so-called "rheoscopic frog." In this course,

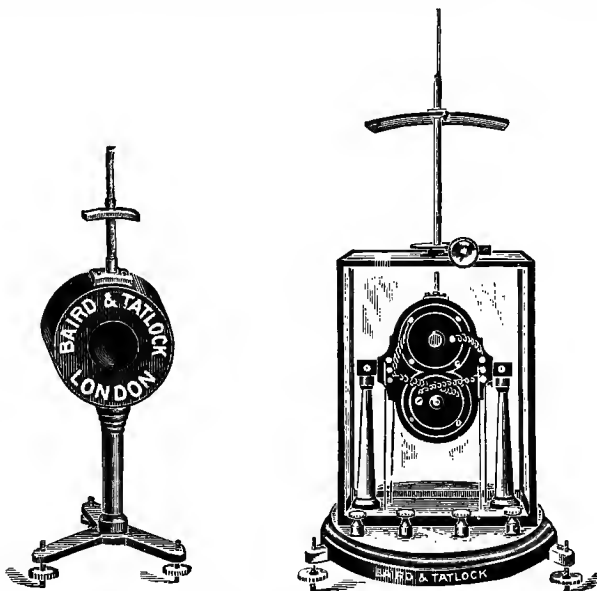

FIG. 86.—Galvanometers.

therefore, the experiments with the galvanometer and the capillary electrometer will be demonstrated to the student and only brief details will here be given.

The Galvanometer employed in these experiments is Kelvin's reflecting galvanometer. It consists of a suspended system of magnets so arranged as to make the system nearly "astatic"; the magnets are

surrounded by coils of many turns of fine insulated wire. The resistance is high, from 5000 to 20,000 ohms. The movements of the mirror attached to the magnets are indicated by a spot of light upon the scale.

The amount of current sent through the galvanometer is regulated by means of a *shunt*, which is a resistance box whereby $\frac{1}{10}$ th, $\frac{1}{100}$ th, or $\frac{1}{1000}$ th of the total current can be sent through the galvanometer

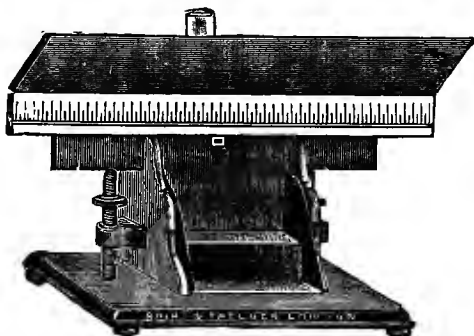

FIG. 87.—Scale and lamp for the reflecting galvanometer.

The electric current from the muscle or nerve is led off by means of unpolarisable electrodes, but before an experiment is performed the electrodes are tested, for in most cases they are not perfectly iso-electric. Any small deflection of the galvanometer due to this cause is compensated by a graduated current from a standard battery sent through the galvanometer in the opposite direction.

Perfectly uninjured muscle and nerve are iso-electric, but they are generally slightly damaged during the process of dissection and preparation. The deflection due to this **current of injury** or **demarkation current** (wrongly called the current of rest) is measured and is then increased by a more pronounced injury caused by touching one end of the muscle with a hot wire. The muscle is now stimulated by a tetanising current applied to its uninjured end; the deflection of the galvanometer is in the reverse direction, due to the **current of action** (formerly called the negative variation) which is produced when the muscle contracts.

The current of injury is, as Gotch pointed out, to be considered as a local current of action; around the injured portion the tissue is in a condition of excitation.

Similar experiments are demonstrated upon nerve.

Lippmann's Capillary Electrometer.—This instrument is a delicate electrical manometer, and is more suitable than the galvanometer for

the investigation of the electromotive properties of the frog's heart; it responds to very rapid changes of electrical potential. It consists (Fig. 88) of a glass tube *C* drawn out at one end to a fine capillary tube; this is filled with mercury and is connected with a pressure apparatus by the rubber tubing *RT*. The capillary tube dips into a small trough filled with 10 per cent. sulphuric acid; the bottom of this vessel is covered with mercury *M* in order to provide good electrical conduction with the platinum wire. The movements of the column of mercury in the capillary tube are observed by means of a microscope fitted with a micrometer scale.

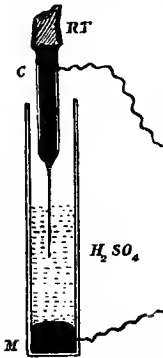

FIG. 88.—Diagram of the capillary electrometer.

The passage of an electrical current through the capillary tube alters the surface tension, and this alteration causes a movement of the mercury in the capillary tube. The movement of the column of mercury is from positive to negative, and the extent of the movement is roughly proportional to the difference in electrical potential. Based upon these facts are the determination of the direction of, and the measurement of the electromotive force of, the current which is under investigation.

With the capillary electrometer the *electromotive properties of the frog's heart* are demonstrated. The base and the apex of the ventricle are led off by unpolarisable electrodes to the electrometer: each time the heart contracts there will be a diaphasic variation, the contracted portion at first becomes negative and then positive to the uncontracted part.

CIRCULATION.

CHAPTER XXV.

THE ANATOMY OF THE FROG'S HEART AND ITS CONTRACTION.

Anatomy of the Frog's Heart.—The cerebrum can be destroyed by the application of a strong pair of Spencer-Wells forceps to the skull. The medulla oblongata and spinal cord are left intact, so that the vasomotor control continues and the circulation is unimpaired. The frog is pinned on the corkplate belly uppermost. The skin over the abdomen is pinched up and slit up to the mouth. The abdominal wall is then divided slightly to one side of the mid line to avoid cutting the anterior

abdominal vein. By a transverse cut the xiphisternum is divided and the junction of the anterior abdominal vein with the heart preserved. The pectoral girdle is next divided in the middle line. The inner blade of the scissors is kept hard against the sternum to avoid injuring the heart beneath. The divided halves of the pectoral girdle are pulled widely apart. The heart is now seen enclosed in a thin membrane—the pericardium. This is picked up with forceps and slit open. A slender band of connective tissue—the fraenum—connects the posterior surface of the heart with the pericardium. A thread is passed under the fraenum with fine pointed forceps and tied. The fraenum is then divided on the side of the thread remote from the heart.

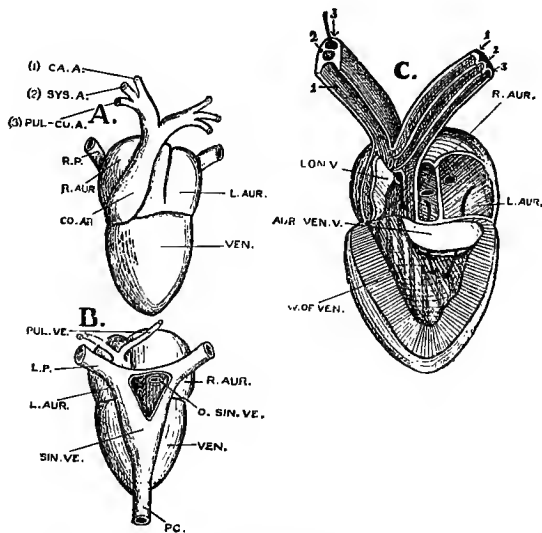

FIG. 89. —The frog's heart. A, Anterior view; B, Posterior view; C, Longitudinal section. (Mudge.)

By means of the thread the heart can be lifted up and turned over for examination. In the front aspect of the heart a single blunt pointed ventricle is seen with the bulbus arteriosus and the two auricles—the bulbus ascends over the right auricle from right to left. It separates into two aortae. Each aorta is divided by longitudinal septa into three channels which soon separate and become the carotid, the aortic, and the pulmo-cutaneous arches.¹ The auriculo-ventricular groove separates the auricles from the ventricle. On turning the heart over the sinus venosus is seen, and the white crescentic line which marks the

¹ The frog respire both by skin and lungs.

junction of the sinus with the right auricle. Entering the sinus from below is a large vein, the vena cava inferior, into which open the hepatic veins. Above there enter the two smaller superior venae cavae. These are seen on gently displacing the auricles. The small pulmonary veins enter the left auricle.

The Contraction of the Heart.—The venae cavae and sinus beat first, then the auricles, and lastly the ventricle and bulbus arteriosus. The blood is returned from all parts of the body to the sinus venosus, whence it passes to the right auricle. From the pulmonary veins the blood passes into the left auricle. The two auricles simultaneously contract and expel the blood into the ventricle. The two blood streams do not readily mix in the ventricle owing to the muscular meshwork within its cavity. When the ventricle contracts the venous blood on the right side is the first to enter the bulbus arteriosus. It is directed by a spiral valve within the bulbus into the pulmo-cutaneous arteries. The spiral valve is then driven over and closes the orifice of the pulmo-cutaneous arch, and the blood (partly arterial and partly venous) now passes into the systemic or carotid arch. The resistance is least in the systemic arch, so most of the blood at first takes this pathway. Finally, as the pressure increases in the systemic arch, the pure blood from the left side of the ventricle is expelled into the carotid artery. Between the auricles and ventricle there hangs the auriculo-ventricular valve. The bulbus arteriosus contains two sets of pocket-shaped valves in addition to the longitudinal spiral valve.

The ventricle becomes smaller, harder, and pale in colour during systole, as the blood is driven out of the muscular sponge-work of which it is composed. It reddens in diastole. Count the beats per minute.

The Tissue of the Heart possesses Automatic Rhythmic Power.—Excise the heart, cutting widely round the sinus venosus, and place it in a watch glass. Note the immediate effect and the after-effect on the rhythm. The beats may at first intermit and then become more frequent, but quickly settle down to about the same rate as before.

The Effect of Temperature on the Rhythm.—Pour on the heart some normal saline solution which has been cooled in ice. The frequency becomes greatly lessened. Replace the cold with warm saline (25° C.). The heart-beats become frequent as the temperature rises. If heated to 40°–43° C. the heart stops still in diastole, but may recover if quickly cooled. If not cooled the heart passes into the condition of *heat rigor*.

Rhythmic Contraction—the function of the Heart Muscle.—Taking another heart, cut away the sinus at the sino-auricular junction. After

a short period of inhibition both parts begin to beat, but with a different rhythm. The sinus is the more injured, and beats at a slower rate. If the cut be made through the auricles, the sinus beat continues and is unaffected by the injury. Cut off the ventricle just above the auriculo-ventricular groove. After a period of inhibition both auricles and ventricle beat. The auricles recover first. Cut through the ventricle below the auriculo-ventricular groove. The **apex preparation** does not beat spontaneously. It responds to a prick by a beat, and may in some cases be taught to beat rhythmically by rhythmic stimulation. A crystal of common salt placed on the apex or the passage of the galvanic current through the apex preparation provokes its rhythmic contraction.

Cut out small pieces of the bulbus arteriosus, and place them under the microscope in a watch glass containing Ringer's fluid. The pieces will beat rhythmically. There are few if any nerve cells in the bulbus, and there are certainly none in some of these pieces, so the rhythm is probably the function of the heart muscle. In support of this are the following facts :

A frog's heart painted with nicotine (1 per cent. solution) continues to beat. Nicotine paralyzes nerve cells.

Isolated portions of the mammalian heart will beat rhythmically for hours if fed through their nutrient arteries with oxygenated blood.

The structural elements of the heart are nucleated, branched, and cross-striated cells. The muscle-cells are joined together into networks and bands, so as to form one functional whole, and hence excitation of any one part leads to the contraction of the whole. The first part to begin to functionate in the embryo is the venous end. In the mammalian heart it has been shown that muscle fibres of a peculiar type connect the auricles with the ventricles ; they form the auriculo-ventricular bundle.

The above experiments suggest that rhythmic contractility is the inherent function of the cardiac muscle. The muscle of the sinus and auriculo-ventricular junction is more embryonic in structure and possesses greater power of initiating rhythm. It is less excitable, and conducts a stimulus less rapidly than the muscle of the auricles and ventricle. The auricular and ventricular muscle is more differentiated in structure. The cross striæ are more marked. It does not so easily initiate rhythm. Owing to its greater excitability and conductivity it follows the lead of the sinus.

During the period of systole the heart is *refractory* to artificial excitation. The excitability returns with diastole, increasing as

diastole proceeds. The energy of any cardiac contraction depends on the previous activity of the heart, on the pressure of the diastolic filling, on the resistance to systolic outflow, temperature, nutrition, etc. It is independent of the strength of the stimulus so long as the latter is efficient. Owing to the refractory period, the slow rate of contraction, and the independence of the amplitude of contraction on the strength of stimulus, the heart cannot be tetanised.

By the study—with the aid of the capillary electrometer or string galvanometer—of the electrical current of action which accompanies the systole, it has been shown that the contraction of the heart is a simple twitch, and not a tetanus. The current of action is triphasic in the mammal—(1) base negative, (2) apex negative, (3) base negative. The excitatory wave travels from base to apex and from apex to base, following the course of the muscle-bands, which start from the base, run to the apex, and, turning in there, ascend on the inner wall of the ventricle. The current of action travels at the same rate as the excitatory state.

The power of slow, sustained contraction seems to depend on the richness of the heart-muscle in sarcoplasm. The heart-muscle possesses tone, and this varies with the temperature and nutrition. Muscarine, acids and chloroform weaken, while digitaline, caffeine, and alkalies increase the tone of the heart. The auricular muscle of the toad exhibits rhythmic alterations in tone.

Antiperistalsis is difficult to produce because the excitatory process in the ventricle is slow, and does not easily affect the more rapidly contracting auricle. The refractory period which persists during systole also prevents antiperistalsis. The excitatory wave is delayed in passing through the more embryonic type of muscle in the sino-auricular and auriculo-ventricular junctions, and therefore the auricle beats in sequence to the sinus and the ventricle in sequence to the auricle. By cooling the sinus and warming the ventricle the sequence of the heart can be reversed, for the excitability of the ventricle is by these means raised, while that of the sinus is lowered.

By gently clamping a strip of tortoise auricle muscle between two little bits of cork an artificial block can be created, and the piece of auricle below the clamp then beats in sequence to the piece above the clamp. The natural delay in conductivity at the auriculo-ventricular junction is thus imitated (Gaskell). The conductivity is decreased by the clamp.

The nerve cells of the heart are placed in the least differentiated parts: in the sinus (Remak's ganglion), in the inter-auricular septum

(v. Bezold's ganglion), and in the auriculo-ventricular groove (Bidder's ganglion). The nerve cells are the cell stations of the vagus nerve. The nervous system regulates, but does not initiate either the rhythm or sequence of the heart. The maintenance of the rhythm depends on the blood, and there is evidence to show that it especially depends on the oxygen, and on the mineral salts which are in solution in the blood.

The chief mineral salts, chlorides and phosphates of sodium, potassium, and calcium, are dissolved in the blood in minute traces, and are in a state of ionisation. The presence of these ions seems to be absolutely necessary for the production of the excitatory state. As the mineral salts in the serum, with a due supply of oxygen and water, are sufficient to maintain the heart in rhythmic activity for hours, it is clear that the heart muscle contains a large supply of contractile material in its sarcoplasm.

CHAPTER XXVI.

METHODS OF RECORDING THE HEART.

The Suspension Method of Recording the Heart-beat.—The frog is placed on a cork plate which is fixed to the stand beneath the lever.

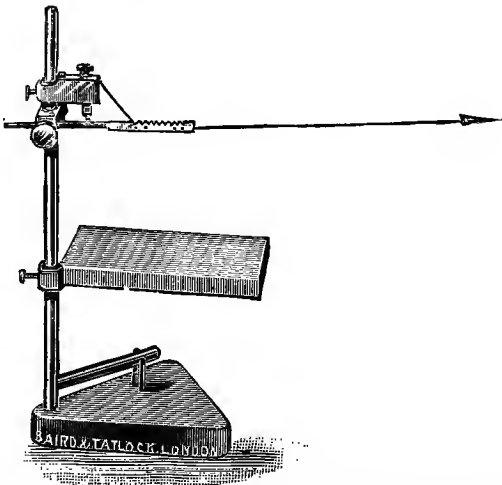

FIG. 90.--Suspension method of recording the contraction of the frog's heart, with use of rubber thread as a spring.

A fine pin is bent into the shape of a hook and passed through the tip of the apex of the ventricle. A thread is attached to this hook and to the lever. The tissues round the base of the heart are pinned down to the cork plate on which the frog rests.

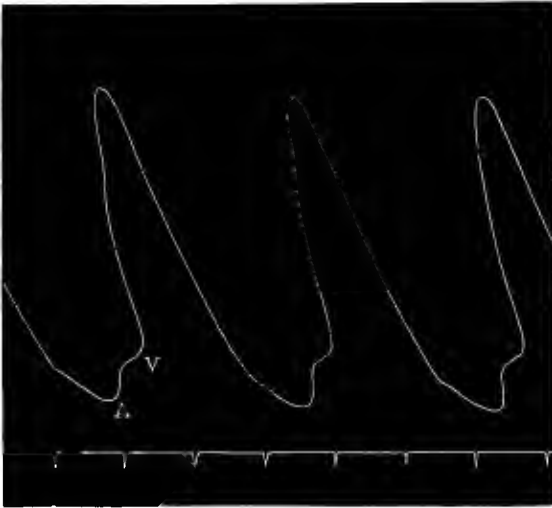

FIG. 91.—Contractions of the frog's heart. A=auricular, V=ventricular contraction. The time is marked in seconds. The curve should be read from left to right. (L.H.)

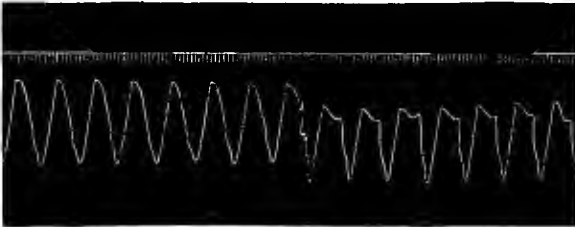

FIG. 92.—Contraction of the frog's heart. The curve should be read from right to left. The effect of rendering heart bloodless. Note the plateau on the top of the normal ventricular curve, and the pointed top after the blood has escaped at the point marked by the star. Time marked in fifths of seconds. (L.H.)

The lever is provided with a long light straw. A fine wire spring is attached to the lever, and the heart pulls against this. Adjust its tension so that the lever is horizontal,¹ and record the heart-beats on a

¹ With the form of heart-lever (Fig. 90) the contraction is represented by the down-stroke; with the lever (Fig. 93) the contraction is indicated by the up-stroke. The curves obtained with the former lever can be best compared with those made with the latter by turning the tracing upside down and reading from right to left.

drum (slow rate). Note the auricular and ventricular curves, and the rounded top or plateau of the ventricular curve. Render the heart bloodless by opening an auricle. The apex of the ventricular curve becomes pointed. Internal tension excites the muscle of the heart to more prolonged and sustained contractions.

Another method of recording the heart is shown in Fig 93. A long light straw lever is taken, and a needle is passed through it. The needle plays in holes in the brass upright. The thread from the heart is attached as shown.

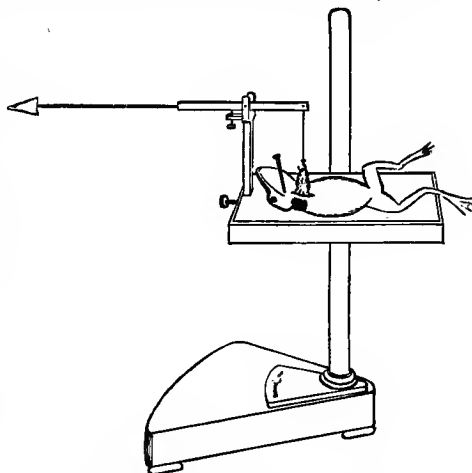

FIG. 93.—Lever, for recording the frog's heart. (Pembrey and Phillips.)

Effect of Heat and Cold on the Excised Frog-heart.—Expose the heart of a pithed frog. Pass a small hook attached to a thread through the tip of the ventricle. Excise the whole heart, cutting widely round it, and pin the tissues surrounding the base of the heart to a cork which is attached to the bottom of the vertical limb of a T-piece. The T-piece is placed beneath the recording lever, and the thread which

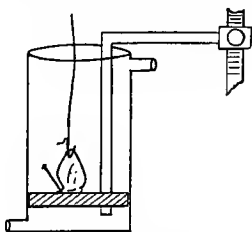

FIG. 94.—Heart chamber.

was attached to the ventricle is fastened to the lever (Fig. 94). Take a tracing of the heart when immersed in a beaker of Ringer's fluid at room temperature (12-15° C.). Ringer's solution is made by saturating 0.65 % NaCl with calcium phosphate and adding to each 100 c.c. of this solution 2 c.c. of 1 % KCl. Next fill the beaker with Ringer's

fluid which has been kept in broken ice, and take another record. The cooled heart gives slow and forcible beats. The periods of contraction and relaxation are prolonged, the frequency greatly diminished. Now fill the beaker with Ringer's fluid at 25° C. The frequency becomes greatly increased, and the period of contraction and relaxation



FIG. 95.—Contraction of the frog's heart recorded by the suspension method 15° C. and then immersed in saline at 25° C. The curve should be read from left to right. The time is marked in seconds. (L.H.)

greatly shortened. A temperature of about 35° C. causes diminution of the tone of the heart. The ventricle ceases to follow the auricular rhythm, although it still responds to excitation. At 38° to 43° C. the whole heart ceases to beat, and gradually passes into the condition of heat rigor. The heat contraction, when once fully established, is not set aside by cooling.

CHAPTER XXVII.

THE STANNIUS HEART.

The Stannius Heart.—The heart of a pithed frog is exposed and a thread is tied to the fraenum which is then cut away from the posterior surface of the pericardium. Pass a ligature under the two aortae and then by means of the thread attached to the fraenum gently pull the heart towards the mouth of the frog. The dorsal aspect of the heart is now readily seen. Draw the ligature round the white crescentic line

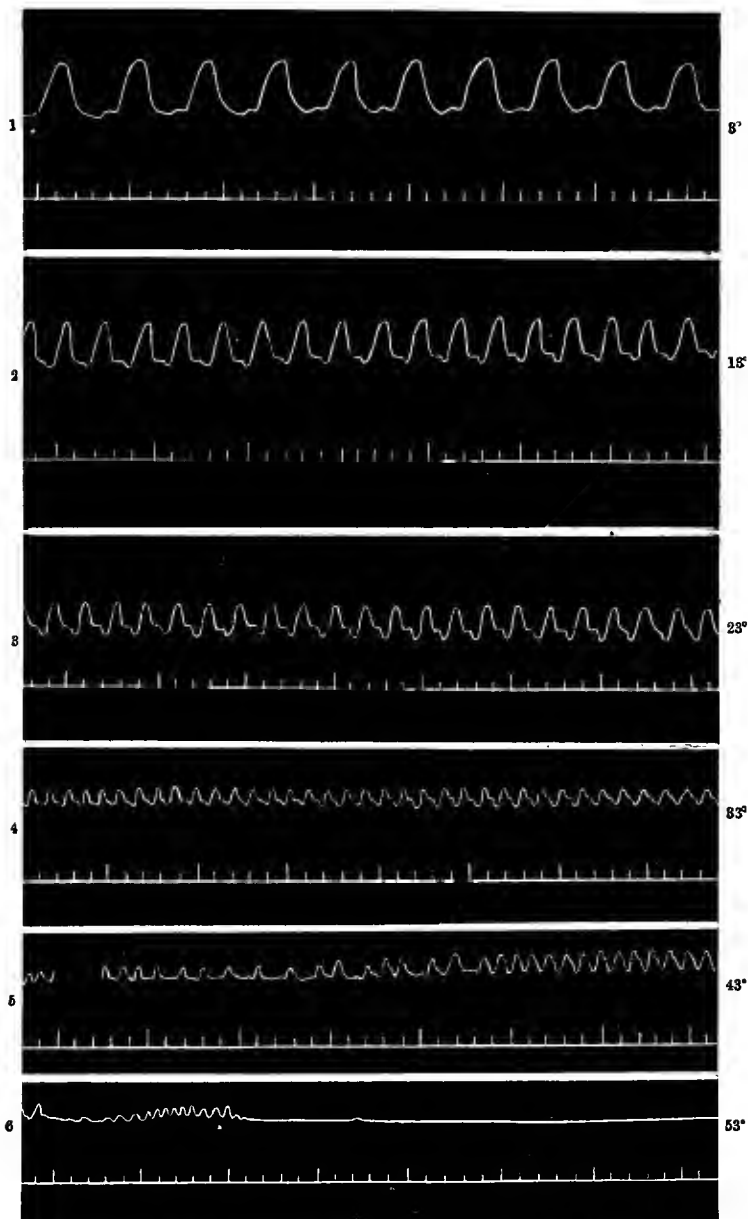

FIG. 96.—Contraction of the frog's heart recorded by the suspension method. Effect of pouring over the heart normal saline at the temperatures indicated. The water cools rapidly when this method is used, and the heart is not heated throughout its mass to the temperature indicated. (Fembrey and Phillips.)

which marks the sino-auricular junction and tie it exactly over this line. The sinus continues to beat, while the auricles and ventricle, after giving a few rapid beats, stand still. The sinus, with its more embryonic type

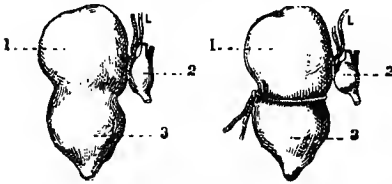

FIG. 97.—Stannius heart. The first and second ligatures (Hedon).

1, Auricles; 2, Sinus; 3, Ventricle.

of muscle, possesses the greatest power of initiating rhythmic contraction. The more specialised muscle of the auricles and ventricle is more excitable, and conducts an excitatory wave more rapidly, but is less capable of initiating rhythm. The excitatory wave which is started from the sinus is blocked by the ligature; thus the auricles and ventricle cease to beat. Prick the ventricle; it will respond by a single beat to each stimulus. The Stannius preparation is like a muscle preparation, and can be used to record the contraction of the heart and the latent period. Tie a second ligature just above the auriculo-ventricular groove. Both auricle and ventricle are excited by the ligature and start beating. The rhythm is no longer the same in the three chambers of the heart. The mere contact of the lever or electrodes resting on the Stannius heart sometimes evokes rhythmic contractions. The inhibitory effect of the first ligature has been attributed by some authors to excitation of the vagus nerve.

The Heart cannot be thrown into Complete Tetanus.—Set up a circuit for giving single induction shocks (see Fig. 16, p. 9). Apply

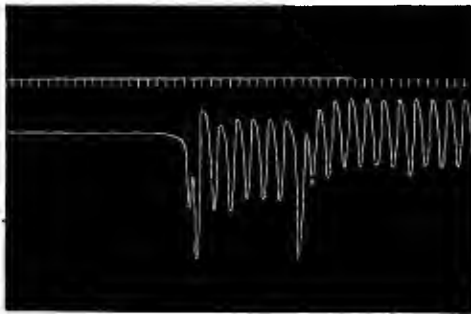

FIG. 98.—Contraction of the frog's heart recorded by the suspension method. The effect of tightening the first Stannius ligature at first gently and then firmly. The curve should be read from right to left. The time is marked in seconds. (L.H.)

the electrodes to the Stannius heart and record the effect of rapidly repeated excitations. The heart gives an incomplete tetanus curve. Owing to the refractory period it cannot be completely tetanised.

The Extra-systole and Compensatory Pause.—Excite with a single induction shock a rhythmically beating heart. The heart is recorded as in Fig. 90 or 93. An extra contraction excited during the diastolic

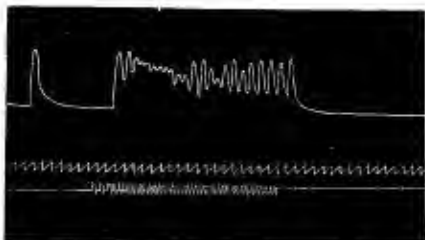

FIG. 99.—Effect of tetanising the Stannius heart. The curve should be read from left to right. The time is marked in seconds. The third line shows the period of stimulation. (L.H.)

period of the rhythmically beating heart is followed by a compensatory pause. Note that the heart does not respond when excited during systole—the *refractory period* (Fig. 150).

This period of inexcitability is seen in skeletal muscle (p. 42), but is of much shorter duration than the refractory period of the heart. The difference probably depends upon a slower metabolism in the cardiac muscle.

CHAPTER XXVIII.

THE CARDIAC NERVES AND GANGLIA.

The Intra-cardiac Ganglia, and Nerves.—The vago-sympathetic nerves enter the sinus with the superior venae cavae, and form a plexus there which contains many ganglion cells (Ramak's ganglion). The nerves pass on to enter the auricular septum, which also contains ganglion cells (v. Bezold's ganglion). Leaving the septum the nerves enter the auriculo-ventricular junction, where third groups of ganglion cells lie (Bidder's ganglion).

To see these structures (Fig. 100), forcibly inject the living heart with osmic acid (1 % sol.), passing the needle of the hypodermic syringe into the auricle. The osmic acid almost instantaneously fixes the heart in distension. Cut out the heart and place it in a watch-glass of 1 % osmic. After 5 minutes open the auricles under water, look for the

septum and cut it out, including its attachments to the ventricle. Mount the septum in glycerine, and examine it microscopically. The nerve fibres and ganglion cells will be apparent in the septum.

Excitation of the Vagi, without dissection.—Destroy the cerebrum and spinal cord of a frog, leaving the spinal bulb uninjured. Stick a needle electrode into each tympanic membrane. Record the beat of the heart and faradise the spinal bulb; inhibition is produced.

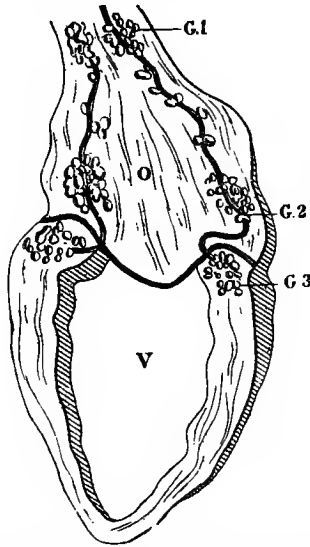

FIG. 100.—Inter-auricular septum and ventricle showing the vagus nerves and ganglia. G. 1 Remak's, G. 2 v. Bezold's, and G. 3 Bidder's. (Hedon.)

Dissection for Exposing the Vagus in the Frog.¹—Lay the pithed frog on its back, and cut through the skin and sternum. Pin out the fore-limbs so as to pull the divided halves of the pectoral girdle widely apart. Open the pericardium and divide the fraenum. From the angle of the jaw on either side trace the thin band-like petro-hyoid muscles. These muscles arise from the skull, and circle round to the thyroid process of the hyoid. The petro-hyoids are crossed by two white nerves, which are clearly visible. One, the glosso-pharyngeal, curves round from the angle of the jaw, and disappears among the muscles of the floor of the mouth. The other, the hypo-glossal, takes the same direction, but lies nearer to the mid-line of the mouth.

The vagus, dividing into its cardiac and laryngeal branches, lies at

¹See also another method of dissection, p. 108.

the lower border of the petro-hyoid muscle. It is a small nerve, and not easily seen. Having traced the nerve so far, cut away the lower jaw and as much of the larynx as can safely be removed. Next cut away the mucous membrane which covers the base of the skull and upper vertebrae. You will thus expose on either side a broad muscle, the levator scapulae inferior. This muscle arises from the skull round the jugular foramen, and is inserted in the scapula. Unpin the frog, and hold the skull in the left hand, so that, while the skull is horizontal, the body hangs vertically. Cut through the levator muscle, and under the upper part of this muscle observe the vagus ganglion and the vagus and glosso-pharyngeal nerves. Trace the sympathetic nerve, which is marked by black pigment, along the upper vertebrae to its junction with the vagus ganglion. The

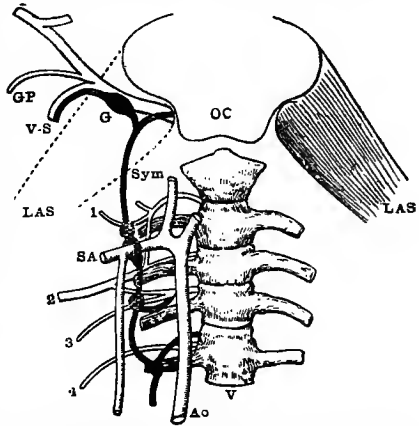

FIG. 101.—Diagram of the origin of the vago-sympathetic nerve (V.-S.). L.A.S.=levator anguli scapulae muscle. Ao.=aorta. 1, 2, 3, 4,=first to fourth spinal nerves. Sym.=sympathetic nerve. G.P.=Glosso-pharyngeal nerve. G.=vagus ganglion. (Gaskell.)

cardiac sympathetic fibres arise from the 3rd spinal nerve, and probably have their cell stations in the third sympathetic ganglion. Pass a fine thread (by means of a sewing needle) under the sym-

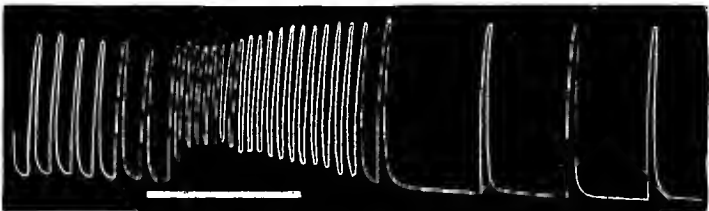

FIG. 102.—Contraction of the frog's heart. The effect of weak stimulation of the vago-sympathetic nerve. The white line marks the duration of excitation. Note the latent time, the acceleration and increased tone and the after-effect. The curve should be read from left to right. (Pembrey and Phillips.)

pathetic at the level of the large brachial (2nd spinal) nerve. Tie it, and divide the nerve below the ligature. Pass a thread under the glosso-pharyngeal and vagus nerves, but do not tie it.

Place the frog again on the board, and record the heart by the suspension method (slow rate of drum). With the interrupted current



FIG. 103.—Contraction of the frog's heart. The effect of strong stimulation of the vago-sympathetic nerve. The white line marks the duration of excitation; the time is marked in seconds. The curve should be read from left to right. (Fembrey and Phillips.)

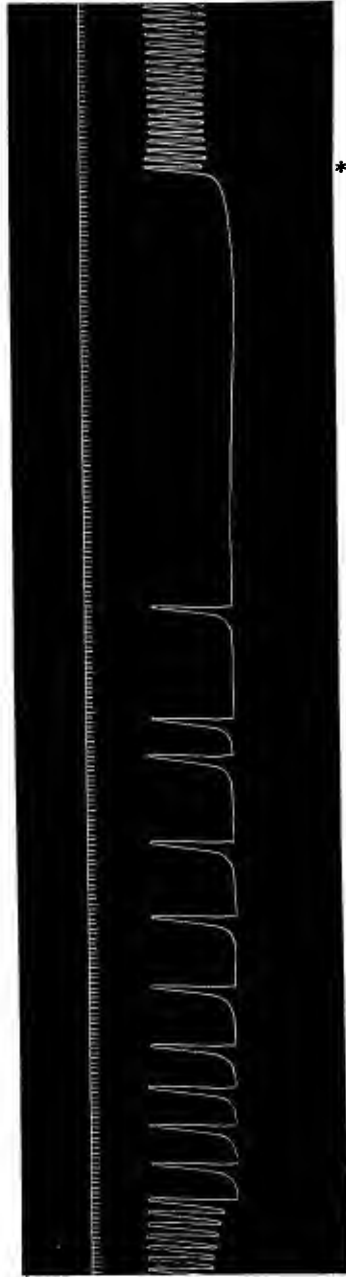

FIG. 104.—Contraction of the frog's heart. Excitation of the vago-sympathetic nerve between the points starred. Note the escape from complete inhibition. The time is marked in seconds. The curve should be read from right to left. (L.H.)

stimulate the sympathetic. Use fine electrodes and a strength of current just comfortable to the tongue.¹

The heart-beats are accelerated and augmented after a long latent period. This effect is prolonged for a considerable time after the excitation has ceased. The after effect is decreased frequency and amplitude.

Next pass the electrodes under the vago-sympathetic trunk. The heart-beats will either be arrested (inhibited) after a brief latent period or decreased in frequency and amplitude. There is a short after effect; the heart soon escapes, even if the excitation be continued. The after effect is usually increased frequency and amplitude. The returning beats frequently show the staircase effect. Sometimes the sympathetic effect overpowers the influence of the vagus. To stimulate

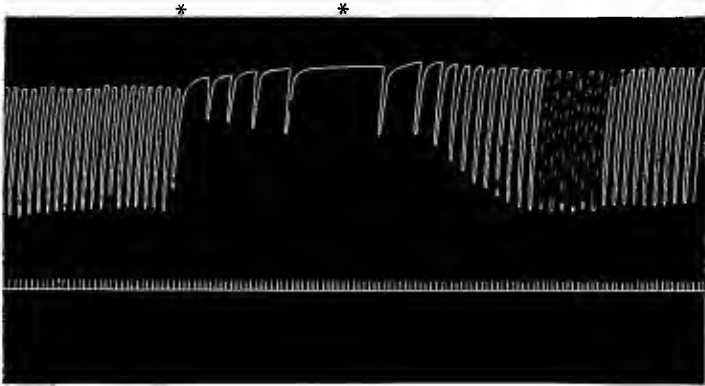

FIG. 105.—Excitation of vago-sympathetic. Note the after effect—a staircase augmentation of the heart-beat. The stars indicate the beginning and end of stimulation. The downstroke represents contraction. (See footnote, p. 98.) The time is marked in seconds. (L.H.)

the pure vagus fibres, the cerebrum is destroyed, the cervical cord divided, and the spinal bulb excited. During the state of complete inhibition the heart may not respond to mechanical excitation.

There is evidence, in the case of the king crab, that the excitatory state is transmitted through the heart and the contraction regulated in sequence by the nerve ganglia of the heart. On the other hand, the ganglion cells, which wander into the embryonic heart of the chick some days after it had started beating, can be removed without disturbing

¹ The electrodes may be made of fine covered wires. The ends, for $\frac{1}{2}$ inch, are stuck together by melted paraffin. The paraffin is grooved with a knife, so as to lay bare the wires at a point $\frac{1}{2}$ inch from their end. The wires are passed through slits in a small piece of cork. The cork may then be pinned in any suitable position.

the cardiac rhythm. Extra-cardiac nerve-fibres from the vagus have their cell-stations in these ganglia. The sympathetic cardiac fibres have their cell-stations in the 3rd sympathetic ganglion in the frog, in the stellate or 1st thoracic ganglion in the mammal. Non-medullated nerve-fibres spin a fine network through all parts of the cardiac muscle. A great many of the cardiac nerve-fibres are centripetal or afferent, and convey impulses up the vagi to the spinal bulb, which reflexly control the tonus of the blood-vessels, and possibly the frequency of the heart

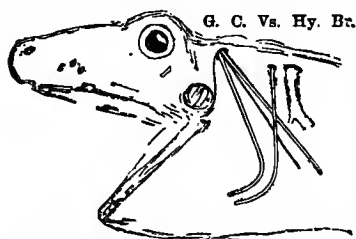

FIG. 106.—Diagram of nerves in the frog's neck. Dissection from behind. (Pembrey and Phillips.)

and the respiration. The centrifugal cardiac nerves influence the frequency and force of the cardiac contraction and the conductivity and excitability of the cardiac muscle. The inhibitory fibres run in the vagus and arise from a centre in the spinal bulb which is in tonic action and curbs the heart. The function of the vagus is to decrease the frequency, force, conductivity and excitability. The sympathetic fibres, which arise in the mammal from the anterior spinal roots in the upper thoracic region, antagonise the action of the vagus. The vagus, by reducing the heart-beat, causes anabolism, and the sympathetic katabolism of the cardiac muscle. The after-effect of vagus excitation is increased energy of contraction, while that of the sympathetic is exactly the opposite. The function of the cardiac nerves is to co-ordinate the beat of the heart to the needs of the body, and to co-ordinate the functions of the other organs of the body to the needs of the heart.

Dissection of Vago-Sympathetic Nerve from behind.—The skin in the mid-line of the back is divided and the scapula lifted up and cut away. The fore-limb is pulled outwards and then removed. A small plug of paper is placed in the frog's mouth to put the parts on the stretch. In front of the divided brachial plexus (Br., Fig. 106) there can be seen (Hy.) a much smaller nerve—the hypoglossal—which is the first spinal nerve in the frog and passes down to the floor of the mouth; (VS.) the vago-sympathetic, which can be traced from the skull, and runs by the side of the carotid artery (C.) and crosses underneath the hypoglossal nerve; (G.) the glosso-pharyngeal. This nerve issues with the vago-sympathetic nerve, but soon turns downwards and forwards to the floor of the mouth. The glossopharyngeal and hypoglossal nerves are then cut and a small piece of the bone containing the foramen from which the vago-sympathetic nerve issues is cut away from the skull. By means of this piece of bone the vago sympathetic nerve can at any time be lifted up without damage and laid upon electrodes.

CHAPTER XXIX.

THE SINO-AURICULAR JUNCTION. THE ACTION OF DRUGS.

Inhibition Produced by Excitation of the Sino-Auricular Junction.—The heart is recorded by the suspension method. Observe the white tendinous line which marks the sino-auricular junction. It is curved with its convexity upwards. This is known as the *crescent*. Pin the cork of the fine wire electrodes to the frog-plate so that the ends of the electrodes touch the crescent. The ends must not be more than 2 mm. apart. Start the drum (slow rate), record half-a-dozen beats, and then tetanise the crescent. The heart, owing to direct excitation of the muscle, at first

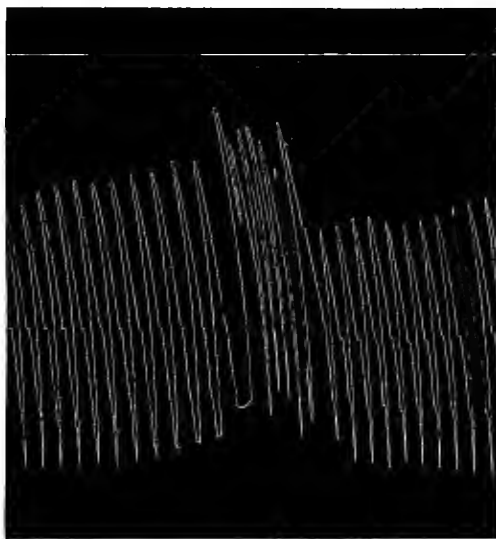

FIG. 107. —Contraction of the frog's heart. Excitation of the sino-auricular junction. Arrest of auricles and increased rate of ventricle (Incomplete tetanus). A pause followed the cessation of the excitation. The curve should be read from right to left. The stars indicate the beginning and end of stimulation. (L.H.)

beats faster, and then is arrested in diastole. Sometimes the arrest does not take place till the excitation ceases. The heart soon escapes from arrest. The arrest is due to excitation of the intra-cardiac branches of the vagus. Mechanical stimulation of the ventricle during the arrest will cause a reversal of the natural sequence. The sinus continues to beat during the period of arrest. The excitatory wave is blocked in the auricular muscle.

Action of Muscarine and Atropine.—Dissect out the vago-sympathetic nerve and record the effect of excitation of (1) the vago-sympathetic,

(2) the crescent. Next with a glass pipette apply to the heart a few drops of nitrate of muscarine (10% solution). The tone, frequency, and amplitude of the heart will decrease until at last the heart becomes arrested in diastole. Mechanical excitation may still excite the heart to give a single contraction.

Now apply some drops of a 0.2—0.5% solution of atropine sulphate. The heart will begin to beat again, at first feebly, and then with

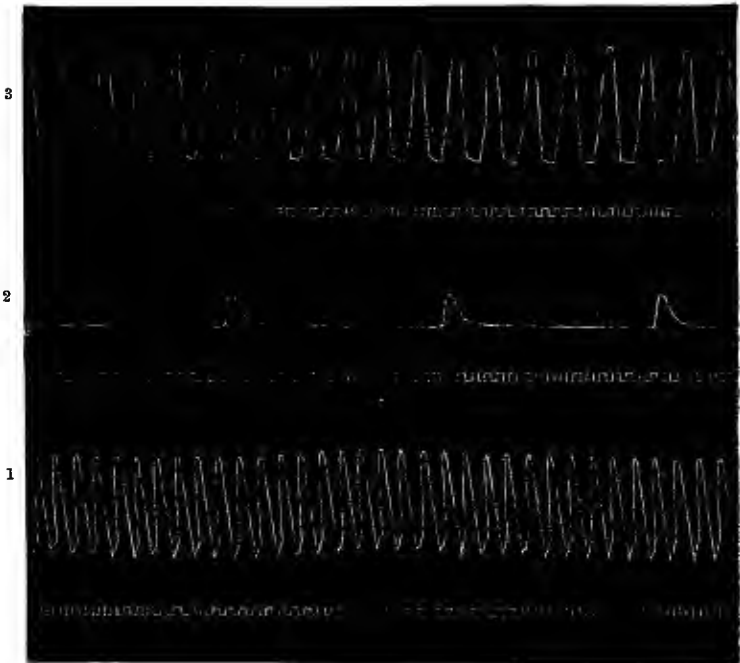

FIG. 108.—Frog's heart. 1, Normal; 2, three minutes after one drop of 10% solution of muscarine; 3, after the application of a weak solution of atropine sulphate. The time is marked in seconds. (Pembrey and Phillips.)

increasing amplitude. Muscarine abolishes the tone, rhythmic power, and conductivity of heart muscle, while atropine has in each respect the antagonistic action. This experiment succeeds on any ganglion-free strip of tortoise heart. After the application of atropine, excitation, either of the vagus or of the crescent, is ineffectual, for atropine paralyzes the post-ganglionic fibres of this nerve. The effect of atropine cannot be antagonised by a further application of muscarine.

A 1% solution of pilocarpine acts in the same way as muscarine, and atropine acts as its antagonist.

Muscarine is an alkaloid obtained from the poisonous Fly Agaric—a

fungus. It is used as an intoxicant in Siberia. It is excreted, unchanged, in the urine, and it is stated that the urine is drunk when the

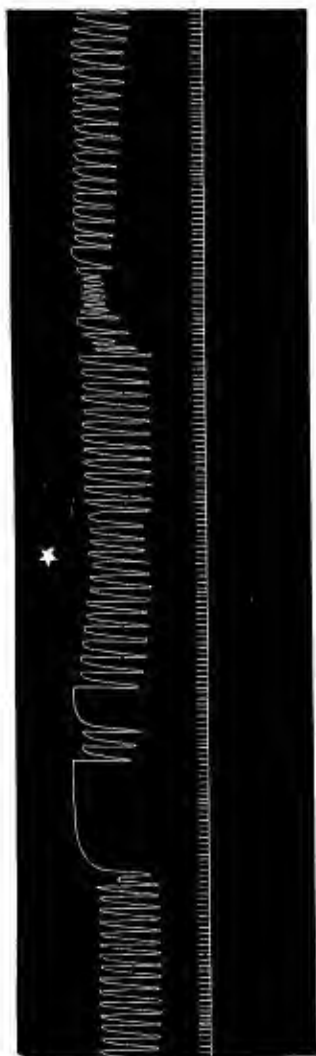

Stimulation after atropine.

Stimulation before atropine.

FIG. 100.—Contraction of the frog's heart. Effect of excitation of the sino-auricular junction before and after atropine. The atropine was applied at the point starred. The time is marked in seconds. The curve should be read from left to right. The downstroke represents contraction. (L. H.)

supply is short, and thus the intoxicant is handed on from one man to another.

Muscarine nitrate, $C_5H_{15}NO_3$, is prepared artificially from cholin, $C_5H_{15}NO_2$. Cholin is one of the decomposition products of lecithin.

CHAPTER XXX.

THE EFFECT OF NICOTINE, CHLOROFORM AND ETHER UPON THE HEART.

Action of Nicotine.—Dissect out the vago-sympathetic and record the beat of the heart by the suspension method. Record the effect of excitation of (1) the vago-sympathetic, (2) the crescent. Now apply to the heart a few drops of a 1 per cent. solution of nicotine. The frequency of the heart is at first lessened and then slightly increased, for the nicotine firstly excites and secondly paralyzes the synapses of

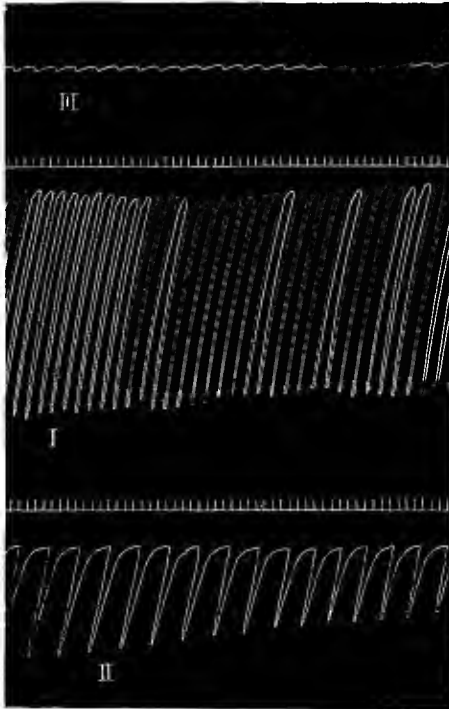

FIG. 110.—Contraction of the frog's heart. I. Normal heart-beat, II. and III. poisoned by nicotine. The downstroke represents contraction. The time is marked in seconds. See footnote, p. 98. (L.H.)

the vagus fibres with the cardiac ganglia. These ganglia contain the cell stations of the vagus fibres. Stimulation of the vago-sympathetic trunk no longer produces inhibition, but augmentation and acceleration. The cell stations of the sympathetic fibres are in the third sympathetic ganglion.



FIG. 111.—Contraction of the frog's heart. Nicotine 1 in 1000 saline. Effect of exciting the sino-auricular junction during the period shown by the white line. Excitation of the vago-sympathetic on the contrary produced no effect. The time is marked in seconds. (Pembrey and Phillips.)

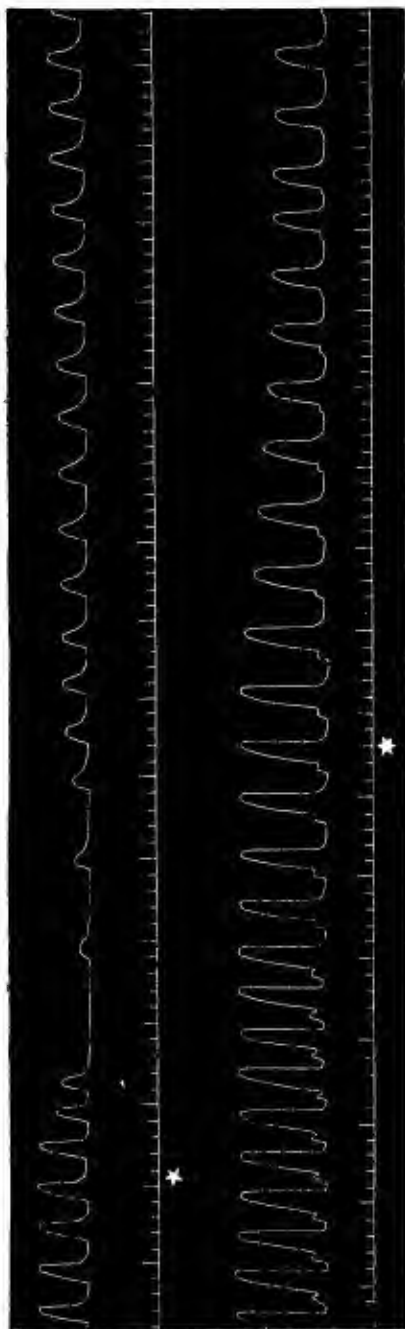

FIG. 112.—Contraction of the frog's heart. Effect of applying a drop of chloroform to the frog-heart at the pointa starred. The time is marked in seconds. (Pembrey and Phillips.)

The vagus fibres are medullated as far as the cardiac ganglia, while the sympathetic fibres are non-medullated after leaving the third sympathetic ganglion (Fig. 113). Stimulation of the crescent still produces

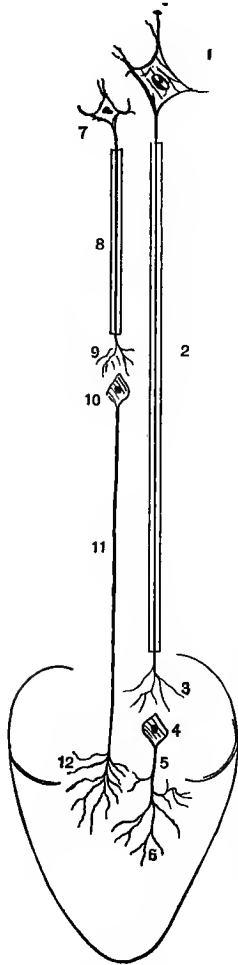

FIG. 113.—Diagram of the nerves of the heart. 1. Nerve-cell of the vagus centre in the medulla oblongata. 2. Medullated inhibitory fibre of the vagus. 3. Its termination around a ganglion-cell (4) in the heart. 4. Post-ganglionic non-medullated fibre and its termination (6) in the muscular tissue of the heart. 5. Ganglion-cell giving rise to the medullated acceleratory fibre (8) in the white ramus communicans. 6. The termination around the nerve-cell (10) of the ganglion stellatum. 7. The post-ganglionic non-medullated nerve fibre and its terminations (12) in the muscular tissue of the heart. The heart is roughly indicated in outline. (Pembrey and Phillips.)

inhibition, for weak doses of nicotine do not paralyse the post-ganglionic fibres. Nicotine is similarly employed to determine the cell stations of all the nerve fibres of the autonomic system (Langley). Too large a dose of nicotine paralyse the post-ganglionic fibres, and renders the contraction of the muscle slow. At this stage stimulation of the sinus will cause a series of rapid beats due to the excitation of the cardiac muscle; this acceleration shows as an after-effect a prolonged period of diastole. Nicotine finally arrests the heart-beat by poisoning the muscle.

Action of Chloroform and Ether.

—Excise two frogs' hearts and place each in a watch glass containing 5 c.c. of Ringer's fluid. To one add one drop of pure chloroform and cover with another watch glass. The heart will become feeble, lose tone, and finally stop beating. It will take considerably more ether to produce the same effect on the other heart. The causation of death from chloroform is cardiac failure. In the mammal the arterial pressure falls, and the vagus centre is rendered hyperexcitable by too concentrated a dose of chloroform. Failure of respiration and syncope result from inhibition and poisoning of the heart.

	By Molecules.	By Weight.	By Volume.
Alcohol, -	1	1	1
Ether, -	8	5	5
Chloroform,	100	40	75

The relative physiological powers of alcohol, ether and chloroform. (Waller.)

CHAPTER XXXI.

DISSECTION OF THE HEART. THE CARDIAC IMPULSE.

The Sheep's Heart.—The heart should, if possible, be obtained with the pericardium intact, and the lungs attached to it. Open the pericardium and test its strength. It is a strong, inelastic, fibrous bag, and prevents the over-distension of the right heart. The parietal layer of the pericardium is attached to the roots of the large vessels at the base of the heart, it thence runs over the surface of the heart, forming the visceral layer. The pericardium in man is attached below to the diaphragm, while above it is slung to the spine by the cervical fasciæ. The heart is thereby slung in position, and cannot twist over during changes of posture.

The front of the heart is recognised by a groove filled with fat, which runs obliquely down the ventricles from left to right. The groove starts from about the middle of the base of the ventricles to a point a little below the middle of the right margin

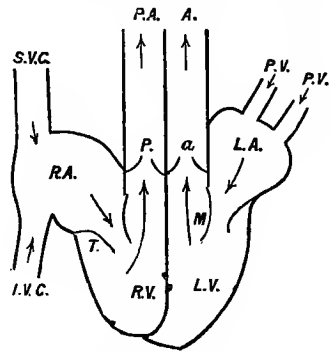

FIG. 114.—Diagram of sheep's heart to show the course of the blood. *S.V.C.* superior vena cava; *I.V.C.* inferior vena cava; *R.A.* right auricle; *T.* tricuspid valves; *R.V.* right ventricle; *P.* pulmonary valves; *P.A.* pulmonary artery; *P.V.* pulmonary vein; *L.A.* left auricle; *M.* mitral valve; *L.V.* left ventricle; *a.* aortic valves; *A.* aorta. (M.S.P.)

of the heart. Running up the middle of the posterior and flatter surface of the heart is a similar shallow groove. The heart is divided by these grooves into a right and left side, and each of these is again divided by a groove containing much fat, which circles round the top of the ventricles. Above this groove lie the right and left auricles. Note the musculature of the left ventricle is thick and firm, that of the right ventricle thinner. Both the auricles are thin walled. The appendix of each auricle projects in front at the base of the heart, as a flat, crinkled, ear-shaped bag. The greater part of the auricles lies at the back and sides of the base of the heart, and is concealed by the aorta and pulmonary artery. The grooves on the surface of the heart mark the position of the septa, which divide the heart into four chambers. Trace the right and left coronary arteries, which issue from the right and left sinuses of Valsalva

in the root of the aorta, and run in the auriculo-ventricular groove. The left is the more important, and divides into the ramus circumplexus and the ramus descendens. Ligation of the left coronary artery causes fibrillar contraction, ending in arrest of the heart beat. Ligation of either of its chief branches may cause fibrillar contraction. Trace the coronary vein in the auriculo-ventricular groove. In the posterior wall of the right auricle find the opening of the vena cava inferior below, and that of the superior vena cava above.

In the posterior wall of the left auricle note the openings of the two pulmonary veins—in man there are *four*. The pulmonary artery arises in front of the base of the right ventricle, close to the anterior intra-ventricular groove. The aorta arises from the base of the left ventricle behind and a little to the right of the pulmonary artery. Tie a glass tube V.C. into the vena cava superior, and ligature the vena cava inferior and the left vena azygos. Tie a second glass tube P.A. into the pulmonary artery. The arterial tube should be two feet, and the vena cava tube one foot long. Fill the V.C. tube with water, the water runs through the right ventricle into P.A. Rhythmically compress the ventricles with your hand. The water sinks in V.C., and rises in P.A. Stop the compression. If the pulmonary valve is competent, the fluid in P.A. will not sink. Note that the root of the pulmonary artery is distended by the pressure of the column of fluid. The same experiment can be repeated, using one pulmonary vein and the aorta. Remove the tubes, and measure the diameter and compare the sectional areas of the two venae cavae, the pulmonary artery and the aorta. Extend the aorta and pulmonary artery. Both have extensile and elastic walls, and although empty, do not collapse. The pulmonary artery is very extensile. The venae cavae and pulmonary veins have thin inextensile walls which fall together.

Pass your finger down the superior vena cava through the right auricle into the right ventricle. Feel the size of the auriculo-ventricular orifice. Now cut through the pulmonary artery just above its origin, and look within. Note the three pulmonary semi-lunar valves. Put the pulmonary orifice under the tap. The pocket-shaped valves close and prevent the water entering the ventricle. Pass a finger through the pulmonary orifice, and another through the superior cava. The two fingers meet in the right ventricle.

Next cut open the right auricle, and observe that it surmounts the right auriculo-ventricular orifice like an inverted pocket.

Note the appendix with its fretwork of muscle—the inter-auricular septum with the fossa ovalis; the Eustachian valve, a membranous fold in low relief, which lies immediately beneath the entrance of

the inferior vena cava. It is directed from the posterior wall towards the internal wall.

Note also the size and form of the auriculo-ventricular orifice. Cut away most of the auricle, and put the auriculo-ventricular orifice for a moment under the tap. The valve will float up. The flaps are brought into opposition by eddies the moment the ventricular pressure becomes greater than the auricular pressure. Note the shape of each flap, and the upward convexity of the valve flaps when closed, and the star-shaped figure formed by their opposition. Note also the papillary muscles and chordae tendineae. A band of muscle—the moderator band—crosses the right ventricle of the sheep's heart.

Next cut through the chordae tendineae, and then place the auriculo-ventricular orifice for a moment under the tap. The valve-flaps are now driven towards the auricle, and the flap is no longer competent. Introduce a pair of scissors between two of the valve-flaps, and cut down to the bottom of the ventricle. Then turn round the scissors and cut up close to the septum, towards, but not as far as, the pulmonary artery. Observe the columnae carnae and papillary muscles in the lower part of the ventricle. These pack together and obliterate the lower part of the ventricle during systole. Acting as elastic cushions, they rebound in diastole and produce a momentary negative pressure in the ventricle. Note the funnel-shaped, smooth-walled upper part of the ventricle—the conus arteriosus—which leads into the pulmonary artery. This part is not emptied during systole, and blood thus remains in contact with the auriculo-ventricular valve, and ensures its closure. Note the form of the flaps of this valve, and their attachment to the auriculo-ventricular ring. Some of the chordae tendineae are attached to the edges, and others to the under surface of the valves. Owing to the papillary muscles and chordae tendineae, the auriculo-ventricular valve presses on the blood during systole, equally with the rest of the ventricular wall.

Now lay open the pulmonary orifice and note the shape and attachment of the semi-lunar valves and the small nodule of tissue in the free edge of each flap. Observe also the sinuses of Valsalva. These favour the formation of eddies, which bring the valves in opposition the moment the intraventricular pressure becomes less than the pulmonary arterial pressure.

Cut open the left auricle in the same manner as the right, and observe the two flaps of the left auriculo-ventricular valve, the papillary muscles, etc., and thickness of the left ventricular wall. Cut across the aorta just above its origin and observe the three aortic semi-lunar valves. Insert the nozzle of the tap through this valve into the left ventricle and turn on the water. The auriculo-ventricular valve closes

and prevents the escape of the water. Lay open the left ventricle in the same manner as the right, carrying the first incision down the left side of the ventricle. Observe the entrance into the aorta and then lay this open. Note the orifices of the coronary arteries from the right and left sinuses of Valsalva.

Scratch away the endocardium and look for the auriculo-ventricular bundle along the top of the interventricular septum on each side. The right and left septal divisions are clearly seen as whitish bands in the

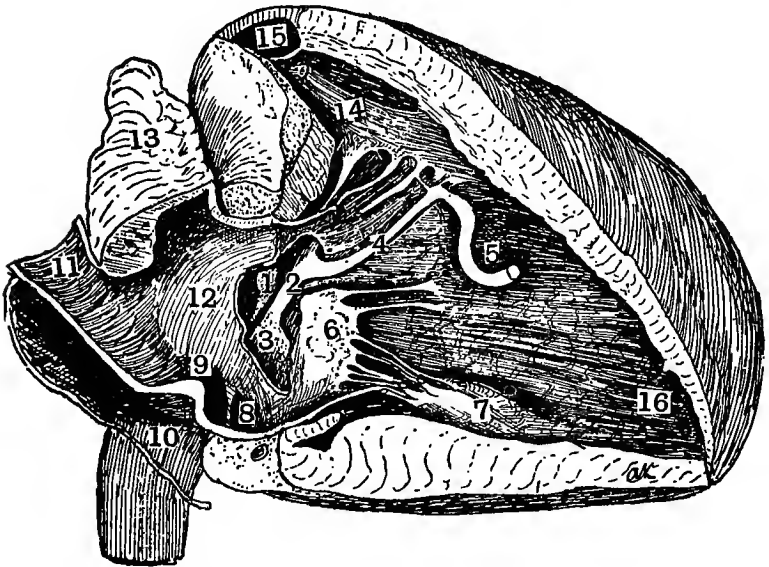

FIG. 115.—Right auricle and ventricle of calf. (Keith.)

1, Central cartilage; 2, main bundle; 3, A.V. node; 4, right septal division; 5, moderator band; 8, orifice of coronary sinus.

sheep's heart. Twigs from the bundle pass by way of the columnae carneae into the muscoli papillares and reach all parts of the heart. The bundle starts from the A.V. node at the base of the interauricular septum on the right side, and is in connection with the sino-auricular node which is supposed to initiate the rhythm. The nodes are made up of peculiar branched cells; Purkinje fibres form the bundle. Section of the bundle interrupts the normal sequence of the heart chambers.

Demonstration of Action of Valves in the ox or horse's heart. (Gad.) Two brass tubes with glass windows are tied one (7 cm. in

diameter) into the left auricle, the other (5 cm.) into the aorta. The brass tubes are connected by side tubes to the bottom and top respectively of a reservoir containing water. A small hole is made in the apex of the heart, and a glow lamp is inserted into the left ventricle. The wires of the lamp are connected with two Grove cells. A tube connected with a rubber bag is tied into the apex. The bag is full of water. On compressing the bag the auriculo-ventricular valves close, while the aortic valves open. On relaxation the aortic valves close, while the auriculo-ventricular valves open (Fig. 116).

The Cardiac Impulse.—Observe and feel the seat of the cardiac impulse when the subject is (1) standing erect, (2) lying horizontal on the left, and (3) on the right side. The impulse is felt in the fifth or fourth intercostal space about $1\frac{1}{2}$ inches below the nipple line, and $3\frac{1}{2}$ inches from the mid-sternal line. It shifts under the sternum when

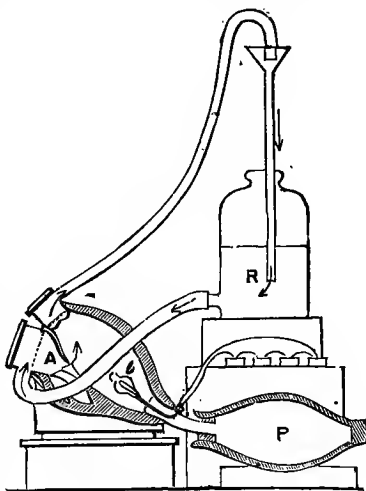

FIG. 116.—Gad's method of showing the action of cardiac valves. (Fredericq.)

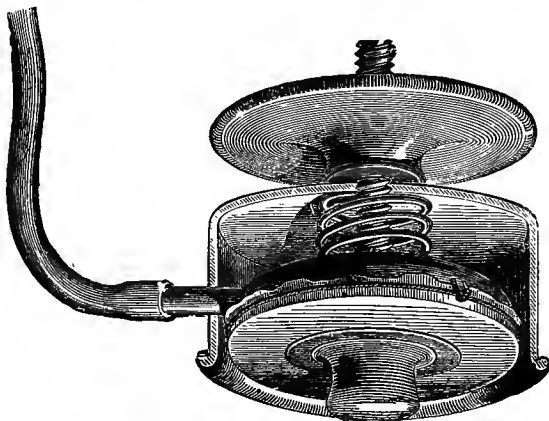

FIG. 117.—Marsy's cardiograph. The tube is connected with a recording tambour. Pressure is adjusted by the screw and spring.

the subject lies on the right, and to the nipple line when he lies on the left side. Owing to the influence of gravity, a different part of the

heart comes in contact with the chest wall in each posture. Apply the button of the cardiograph to the seat of the impulse, and fix it with tapes. One tape is fastened round the chest and one over the right



FIG. 118.—Impulse curve of boy aged 15. The moments when the heart-sounds were heard are marked. Time marked in fifths of a second. (L.H.)

shoulder. Connect the cardiograph by means of a **L** tube with a recording tambour, and take records on a moderately fast drum. The **L** tube is used to regulate the pressure in the tambour. A small metal

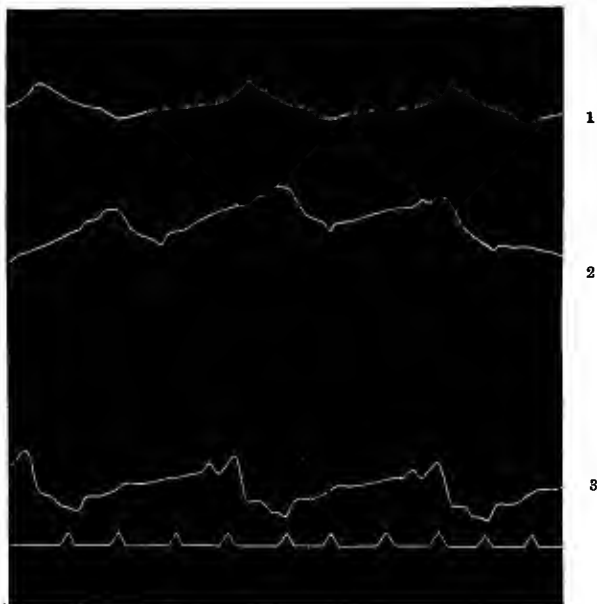

FIG. 119.—Form of impulse curve changed by altering the position of cardiograph. In 3 the chest wall is sucked in during the systolic output. Time marked in fifths of a second. (L.H.)

box—the size of a penny and open at the bottom—does very well, if connected to a tambour and pressed over the region of the apex. To interpret the curve, adjust another receiving tambour to the carotid pulse and arrange the writing styles of the receiving tambours to write

in the same perpendicular. Set up a signal, spring key, and battery, in circuit. Listen to the heart sounds and try to mark the first and second sounds beneath the cardiogram (Fig. 118). The signal must write exactly under the writing style of the tambour. The reaction time of a trained observer for making signals in answer to sounds is 0.15 to 0.20 seconds. The curve is only typical when the button of the instrument is exactly applied to the seat of the impulse. Elsewhere the thorax is drawn in, as blood is expelled from the thorax during the period of systolic outflow (Fig. 119).

The impulse of the heart occurs where the ventricular wall touches the chest. It is produced by the sudden hardening of the ventricular muscle. During the first part of systole—the period of rising tension—the blood cannot escape from the ventricles.

The second tambour can then be placed over the jugular vein and a venous pulse recorded. This will show the time of the auricular contraction. (See p. 122.)

CHAPTER XXXII.

THE PULSE. HUMAN BLOOD PRESSURE.

Pulse.—Examine the radial pulse with the finger. Note (1) the size of the swelling, composed of the artery and its venae comites, which occupies the radial sulcus; (2) the tension of the artery, which is estimated by the pressure required to obliterate the artery and stop the pulse; (3) the condition of the arterial wall, which can be ascertained by rolling the vessel upon the bone; (4) the character of the pulse wave—its frequency, regularity, amplitude, and period of duration. Note also whether the chief secondary or dicrotic wave is perceptible.

Compress the brachial artery, and notice that the radial pulse ceases. Compress the upper arm, excluding the brachial artery, and note the effect on the veins and pulse. The pulse may be recorded by a sphygmograph. The principle of this instrument is a button resting on the artery and pressing against a steel spring. The spring in its turn is made to press either against a lever (Fig. 121) or a tambour. The lever is provided with a writing style, while if the tambour be used it is connected with a recording tambour. The Dudgeon sphygmograph

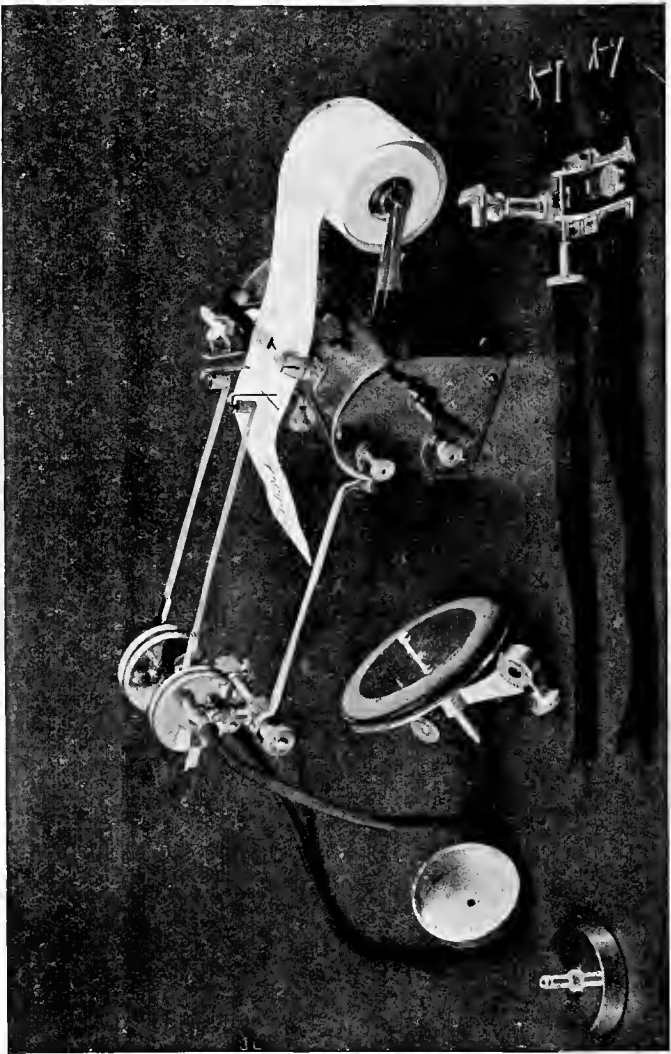

FIG. 120.—Mackenzie's Polygraph.

is convenient, but Mackenzie's polygraph allows long continuous tracings to be taken in ink on white paper, and is a far more valuable clinical instrument. Apply the sphygmograph to the radial artery, as in Fig. 121. The right position of the button may be found by marking

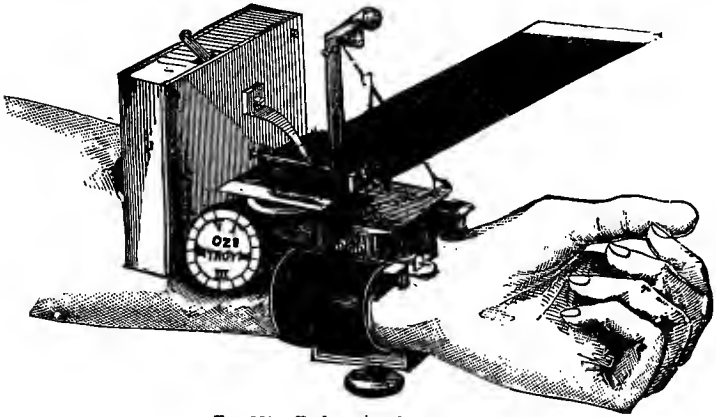

FIG. 121.—Dudgeon's sphygmograph.

the position of the pulse with ink. The pressure of the instrument can be varied both by the straps and by the dial which regulates the pressure of the spring. The instrument should be applied with a pressure sufficient to flatten the artery, and then the pressure should

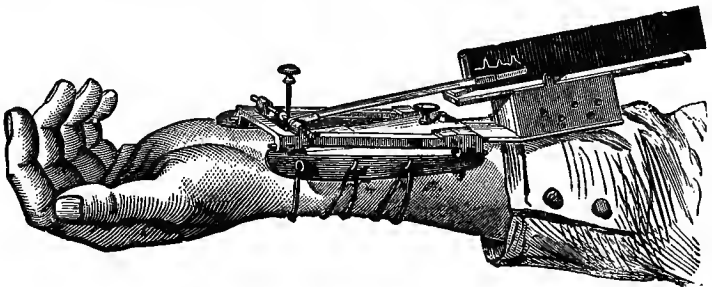

FIG. 122.—Marey's sphygmograph.

be diminished until the maximal excursion is obtained. We have no means of accurately reading the pressure of the spring or the changes of pressure indicated by the pulse curve. The instrument gives us the form of the pulse curve only. When the smoked paper is in position, and the writing style placed upon it, and the maximum excursion obtained, the clock is started and the record taken. The pulse curve consists of a primary and several secondary waves. The primary wave is the wave of expansion produced by the systolic output of the heart

and travels down the elastic arteries at the rate of about 5–8 metres a second. The secondary waves are produced by the elastic vibrations of the wall of the large arteries which result from their sudden distension. The first secondary, or predicrotic wave is probably produced by the final contraction of the base of the heart, which wrings the blood out of the ventricle. The second or dicrotic wave follows the dicrotic notch. The dicrotic notch is synchronous with the tension of the closed semilunar valves and the second sound of the heart.

The dicrotic notch is caused by the back swing of the blood towards the closed aorta valves, and the wave by the rebound. The size of the dicrotic wave depends on its relation to that phase which the primary wave happens to be in, as well as on the conditions which increase the back swing and rebound. A forcible beat and an arterial system which can quickly empty itself favour dicrotism.

The sphygmograph fixed by a band round the wrist may act like a plethysmograph, and be affected by changes of *volume* in the limb. To avoid this, the instrument is suspended, and thus applied to the artery without use of the band.

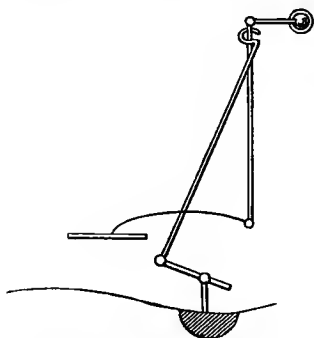

FIG. 123.—Arrangement of levers in Dudgeon's sphygmograph.

Take another pulse tracing, using this device, and forcibly inspire and expire during the record.

A deep intercostal respiration, if not prolonged, yields a fall of pressure, and, conversely, a deep diaphragmatic inspiration yields a rise. But the effect of respiration is very complex, and it is difficult to say what the effect of normal respiration in any individual case will be. The ordinary statement that inspiration raises and expiration lowers blood pressure is not borne out by the records. (T. Lewis.) The pressure falls during forced breathing. The fall occurs with inspiration, and is caused by the violent contraction of the diaphragm obstructing the vena cava inferior.

In Valsalva's experiment, a deep expiration with mouth and nose shut, the abdominal and arterial pressure rise. A stiff walled rubber tube inserted into the rectum and connected with a manometer indicates the big changes of abdominal pressure thus produced, *e.g.* +20–+90 mm. Hg.

Blood Pressure in Man.—The pressure may be measured by the Leonard Hill sphygmometer. This consists of a graduated glass tube,

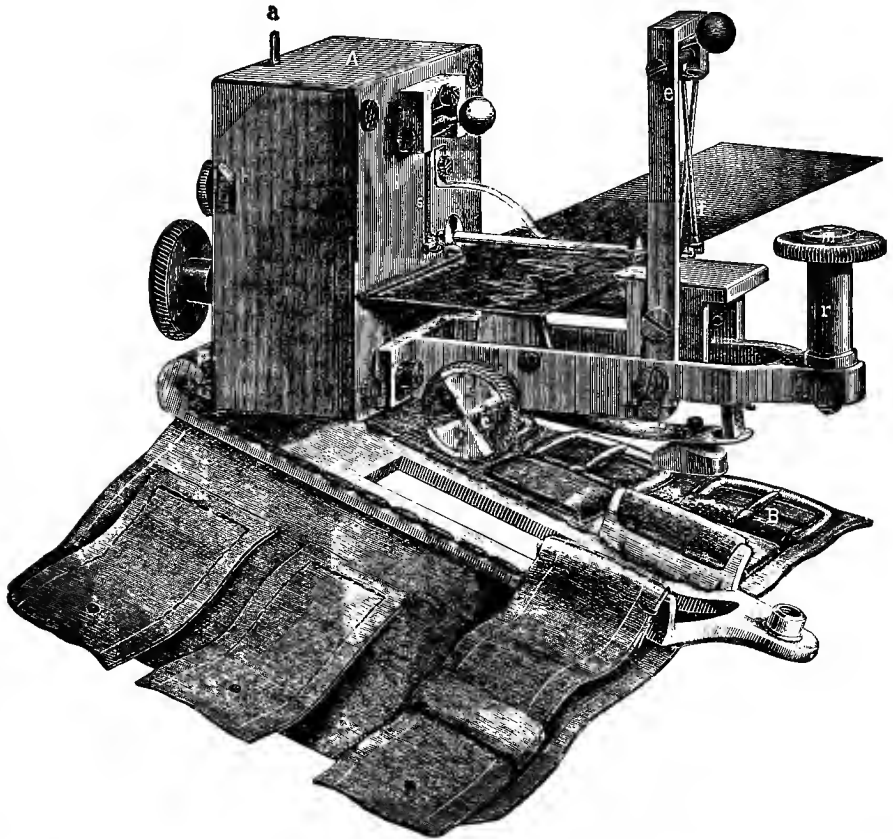

FIG. 124.—Sphygmograph provided with time writer (Jacquet)

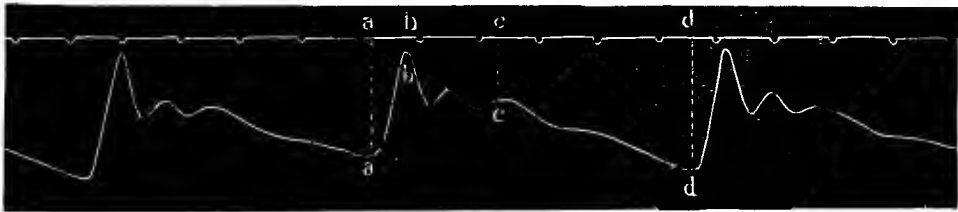

FIG. 125.—Pulse tracing (sphygmogram) taken by Jacquet's sphygmograph.
a d = the period of the pulse curve, *b* = the primary, *c* = the diastolic wave.
 Time marked in fifths of a second.

which has a small air-chamber above. Near the open end is a side hole—the zero of the scale. On placing the open end in water, a meniscus rises to the side hole.

A short length of rubber tubing, attached to a rubber bag, is slipped over the open end so as to cover the side hole. The bag is half distended with air, and is enclosed in a silk cover. The bag being enclosed by the palm of the hand, and the gauge held erect between

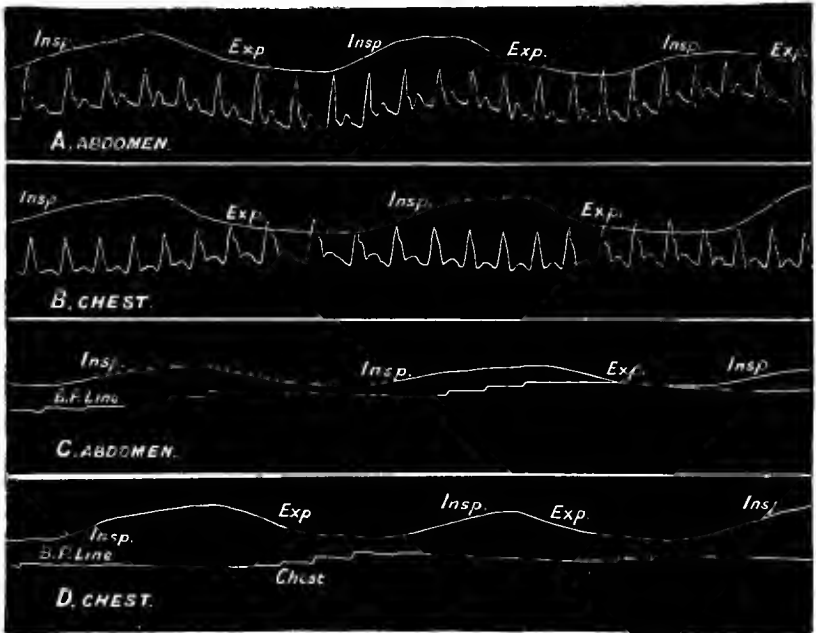

FIG. 126.—Effect of abdominal and chest breathing. (Lewis.)

the fingers, the bag is pressed down upon the radial artery of the subject, the thumb exerting counter pressure against the back of the wrist. The index finger of the other hand feels when the pulse is obliterated, while the second finger prevents, if necessary, the pulse getting through from the anastomoses with the ulnar artery. The water used for the meniscus is made alkaline with potash to avoid the effect of grease in the tube. If the meniscus does not rise to the side hole, blow through this and try again.

The air-chamber acts as a spring, and the instrument is a spring manometer. The meniscus is set before each reading, so as to avoid errors due to alterations of temperature and barometric pressure. The

instrument is graduated empirically. While taking the reading the hand of the subject must be placed on the same level as the heart, so as to avoid the influence of gravity.

Measurement of Systolic Pressure with Hill-Barnard Armlet and Mercurial Manometer.—Strap the armlet lightly around the middle of the upper arm. Palpate the radial artery. By working the pump, raise the pressure in the cuff until the radial pulse is imperceptible. Now manipulate the exhaust stop cock so that the pressure in the cuff very gradually falls, and observe carefully the height of the mercury in the manometer. Whenever the radial pulse reappears, note the pressure. Continue the decompression (best by slightly lowering it a few mm. at a time), and note the pulsations of the

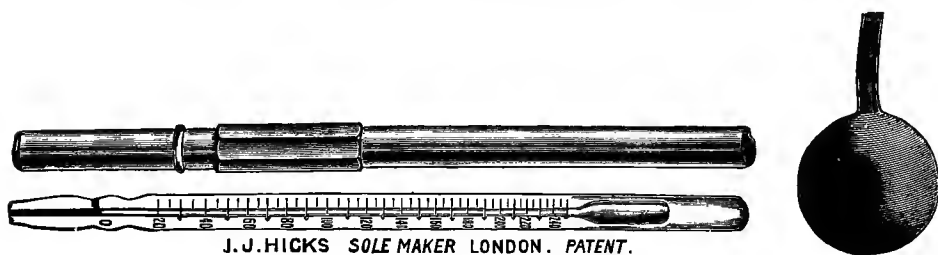

FIG. 127.—Leonard Hill sphygmometer.

mercury, which became evident at the systolic pressure, get gradually of greater amplitude until, by further lowering of pressure, they become smaller again. The pressure at which the pulsations are of maximal amplitude is the *diastolic* pressure.

The difference between the two pressures is the *pressure pulse*.

Repeat the above observations until constant results are obtained. Then let the observed person run up and down stairs several times, and repeat the observations.

Try the effect of putting the hand in very hot water, and palpate the artery at the elbow and wrist. The pulse will disappear earlier at the wrist. A contracted artery conducts the crest of the systolic wave better than a softened artery. The effect of the hot water is more evident after exertion, when the pulse waves are larger.

The systolic arterial pressure is 100–110 mm. Hg in healthy young men. It may fall during sleep 10–20 mm. Hg, and rises to 130–140 and to even 200 mm. Hg during mental excitement or severe effort. The arterial pressure is as constant as the body temperature from day to day. In the horizontal posture the arterial pressure will be found to be the same in all the big arteries. In the erect posture the pressure is

higher in the post-tibial than in the brachial by the height of the column of blood which separates the two arteries. The effect of gravity is compensated. The reverse is the effect in states of debility, and the pulse frequency is then greatly accelerated in the vertical posture. The venous pressure may be obtained by placing the armlet round the fore-arm, raising the pressure in it, emptying the blood out of a vein

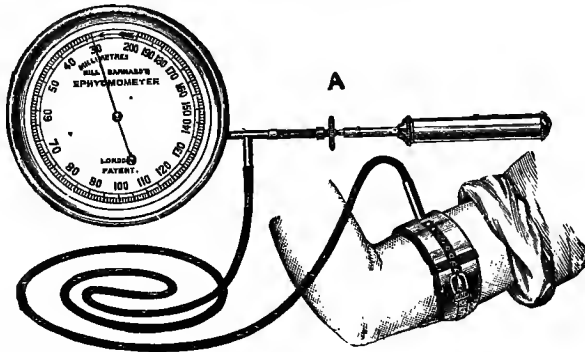

FIG. 128.—Spring sphygmometer. The leather armlet encloses a rubber bag. The bicycle pump is used to raise the pressure. The spring manometer indicates the maximal pulsation and the pressure.

above the armlet by digital pressure, and then diminishing the pressure until the vein suddenly fills. Note the pressure when this happens.

Place the other armlet round the upper arm and raise the pressure in it nearly to the systolic pressure, keep it at that, and observe that the venous pressure rises after a minute or so to this pressure. Observe the effect on the veins of holding the arm in the dependent posture and motionless, of contracting the muscles, of raising the arm, etc.

CHAPTER XXXIII.

BLOOD. THE HAEMOGLOBINOMETER AND THE HAEMACYTOMETER.

Gowers-Haldane Haemoglobinometer.—The maximal error of this admirable instrument is not more than 0·8 per cent. The standard solution in tube D is a 1 per cent. solution of ox blood saturated with coal gas.¹ The oxygen capacity of the ox blood from which the standard was prepared was 18·5 per cent. This was determined by

¹ Coal gas contains carbon monoxide as an impurity.

displacing the oxygen from laked ox blood with ferri-cyanide of potassium, and measuring the amount of gas. The percentage of haemoglobin corresponding to 18.5 per cent. is about 13.8 per cent. The normal human blood when saturated with CO and diluted with water to the mark 100 in tube C corresponds in tint to the standard, and has therefore an oxygen capacity of 18.5 per cent.

Add distilled water to tube C up to the mark 20. Take exactly 20 c.mm. of blood in the pipette, and blow it into C. Pass a narrow glass tube connected with a gas burner into the free part of tube C. Turn the gas on and push the glass tube down near to the blood. The gas tube is then withdrawn, and tube C quickly closed with the finger to

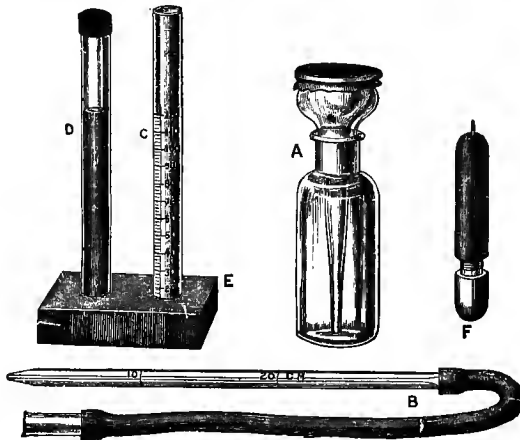

FIG. 129.—Gower's haemoglobinometer.

prevent the gas escaping. The tube is then inclined up and down about a dozen times, so that the haemoglobin becomes saturated with CO.

Distilled water is then added drop by drop from the dropping pipette A, until the tint appears equal to the standard. After half a minute read the percentage, and then add another drop or drops till the tints appear just unequal. Read the percentage again, and take the mean of the two readings as correct. In comparing the tints hold the tubes against the skylight, and frequently change the tubes from side to side. Many other forms of haemoglobinometer have been contrived, but in comparison with this instrument none of them are worth notice.

The number of Corpuscles in the Blood.—The Thoma-Zeiss **Haemacytometer** consists of a counting chamber and an accurately calibrated pipette.

The finger behind the nail is cleaned with alcohol and ether, and a drop of blood is drawn by the stab of a lancet-shaped needle. The finger should not be constricted by a ligature during this operation. The point of the pipette is placed in the drop, and the blood is aspirated as far as the mark 1. The traces of blood on the point of the pipette are then removed, and the pipette is dipped into Hayem's fluid.¹

This fluid is sucked up until the diluted blood reaches the mark 101. The tip of the mouth-piece is then closed by the finger, and the pipette shaken. The glass bead in E mixes the blood and Hayem's fluid. The bulb contains 1 part blood and 99 Hayem's fluid.

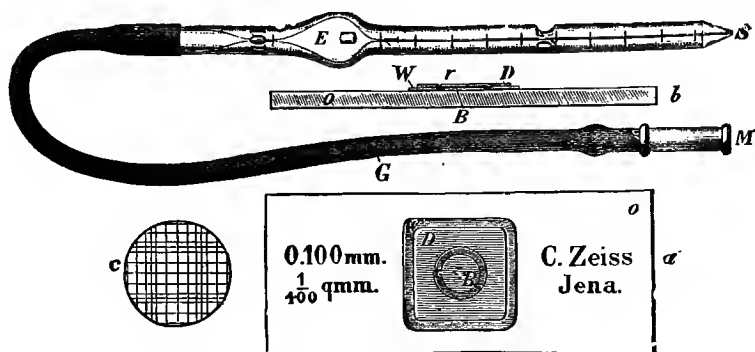

FIG. 130.—The Thoma-Zeiss haemocytometer.

Now blow gently into the mouth-piece, reject the first few drops, and then place a drop upon the centre of the counting chamber. The cover-slip is then placed in position, and the counting chamber is placed on the stage of the microscope, and left at rest for a few minutes. When the corpuscles have subsided, count the number in 10 squares, and take the average. Count those corpuscles which happen to lie on the lines on two sides of each square only. Each square covers an area of $\frac{1}{400}$ sq. mm., and has a volume of $\frac{1}{4000}$ c.mm., therefore 1 c.mm. contains 4000 times the average number found in a square. The dilution of the blood was 1:100. Thus the number in a square $\times 4000 \times 100 =$ number of corpuscles in 1 c.mm. of blood.

In counting the white corpuscles it is best to dilute the blood with 1 per cent. acetic acid. This destroys the red corpuscles and brings the white clearly into view. By comparing the number of the red

¹Sodium chloride, g. 2; sodium sulphate, g. 10; corrosive sublimate, g. 1; water, g. 400.

corpuscles in a square with the percentage of the haemoglobin, the worth of the corpuscle in haemoglobin is obtained.

$$\frac{\% \text{ of Hb}}{\text{No. in sq.}} = \text{'worth' of corpuscles.}$$

The average number of red corpuscles is 5,000,000 per 1 c.mm.; of white, 10,000 per 1 c.mm.¹

Specific Gravity of the Blood.—A number of test tubes are taken and filled with mixtures of glycerine and water, which vary in specific gravity from 1030 to 1075. A pipette is taken with the point bent at a right angle. The skin is pricked behind the finger nail, and a drop of blood is drawn into the pipette. The blood is blown in small droplets into the middle of the solution in several of the test tubes until the solution is found in which the blood neither sinks nor rises. The specific gravity of this solution is determined with the hydrometer. The behaviour of the droplet must be noted at the moment when it enters the solution. The blood quickly alters owing to osmotic change. The specific gravity of the blood is about 1060, of the plasma 1026-29. The specific gravity of fragments of muscle or other tissues may be determined in the same way. The method is thus employed to determine the amount of tissue-lymph in the organs.

CHAPTER XXXIV.

CIRCULATION OF THE BLOOD (ELEMENTARY DEMONSTRATIONS).

Proofs of the Circulation of the Blood.—A mammal is anaesthetised with ether and chloroform.

The external jugular vein is exposed and the carotid artery. A clip is placed on the jugular vein. Note the central end of the vein empties, while the peripheral end becomes enlarged. A clip is next placed on the carotid artery, the central end becomes distended and pulsates, while the peripheral end shrinks and ceases to pulsate. The clips are now removed and two ligatures placed in position (but not tied) under each vessel. The vein is pricked. Note the dark blood which flows out from the peripheral end steadily and without force. The vein is then tied above and below the opening. The artery is next pricked. Note the blood spurts out forcibly and in jets from the central end. The artery is then tied above and below the opening.

¹ After using, clean the pipettes of these instruments. Suck water, alcohol, and ether up them in turn, and let the liquids run out. Never blow down the pipettes.

A tracheal cannula is placed in the trachea and connected with the artificial respiration apparatus. The sternum is divided in the mid-line, and the thorax opened, so as to expose the heart. The pericardium is slit open. Observe the systole and diastole of the

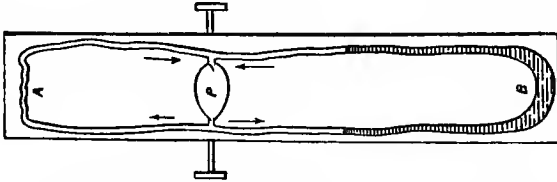

FIG. 131.—Simple model to show the effect of gravity on the circulation.

auricular appendices and ventricles. Ligatures are now passed under the superior and inferior venae cavae and tightened. The heart quickly empties. On loosening the ligatures observe the immediate filling of the right heart. A ligature is next passed under the aorta and tightened. Observe the engorgement, firstly, of the left, and then the right heart. On loosening the ligature note the effect. A ligature is next passed under the pulmonary artery and tightened. The right heart becomes engorged while the left empties. On loosening the ligature note the result. The heart is now excised, the right ventricle quickly opened. The papillary muscles may be observed contracting synchronously with the ventricular wall.

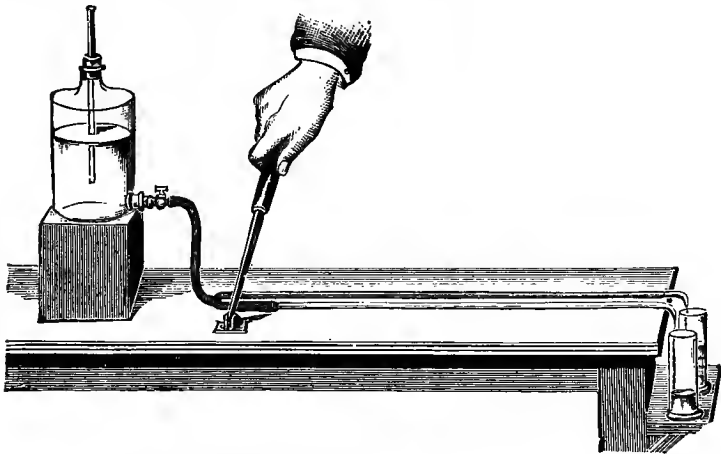

FIG. 132.—Schema to show the flow in rigid and elastic tubes. (Marey.)

The Flow in Rigid and Elastic Tubes.—Arrange an experiment as shown in figure 132. The two tubes are 1 metre long and of the same bore, but one is a rigid tube and the other elastic. A toy-rubber balloon

inserted in the course of a glass tube will act better than a rubber tube. The middle of a piece of glass tube is drawn out into capillary size and divided, so that outflow orifices are obtained of the same size. Rhythmically open and shut the compressor. The flow from the rigid tube is intermittent, while from the elastic tube it is continuous. The latter delivers more fluid in one minute than the former. Observe that the outflow from the elastic tube becomes intermittent when the outflow orifice is enlarged. The increased and continuous flow from the elastic tube is due to the potential energy stored up in the stretched wall of the tube, which maintains the flow during diastole.

The Artificial Schema.—The two ends of a Higginson syringe *B* are connected with a soft rubber tube about $\frac{1}{4}$ inch in diameter and a yard long. The tube divides into two channels; (1) a short length of wide glass tube (a lamp chimney with a cork will do) filled with shot representing the capillaries, (2) a rubber tube closed by a screw-clip. The screw-clip represents the muscular wall of the arterioles. These are connected with the inner tube of a bicycle tyre, which represents the capacious venous system. A mercury manometer is connected by a \perp tube with the artery and another with the vein. A loose cotton wad plug is placed in the open end of each manometer to prevent the mercury being accidentally forced out. The system is filled with water, and air removed by tilting the board to which the schema is fixed and working the pump; the air is allowed to escape through a side tube at the top of the schema. The schema is filled only so far that the vein is not distended and there is no positive pressure when the pump is at rest, so as to represent the conditions in the dead body. The bulb of the syringe may be worked by hand. The valves act as the mitral and aortic valves. When the screw-clip is widely open, there is little resistance to flow. The outflow from the artery into the vein ceases during the diastole of the syringe. The conditions are the same as if the artery were a rigid tube. The diastolic and systolic variations of pressure are very great, and affect both manometers to a like extent. Screw up the clip. The flow, as the resistance increases, becomes less and less intermittent and finally continuous. The mean pressure rises in the arterial manometer. The systolic and diastolic variations of pressure become greatly reduced. The systolic variation disappears in the venous manometer. When the vascular system is formed of a wide tube free from constrictions, each systolic pulse-wave travels with so great a velocity that the whole system reaches the same pressure before the next systole of the heart occurs. The conditions are otherwise when the clip is screwed up, for the friction of the blood flowing through the narrow channels prevents the blood from passing

with anything like the velocity of the pulse-wave. In the vascular system the pulse-wave travels in the arteries 8 metres per second, while the blood travels $\frac{1}{3}$ -metre.

The resistance to flow is chiefly situated in the arterioles, where the velocity is high. It is due to the friction of the moving concentric layers of blood against one another, and against the stationary layer which wets the walls of the blood vessels. It is proportional to the surface area, to the viscosity of the blood—nearly proportional to the square

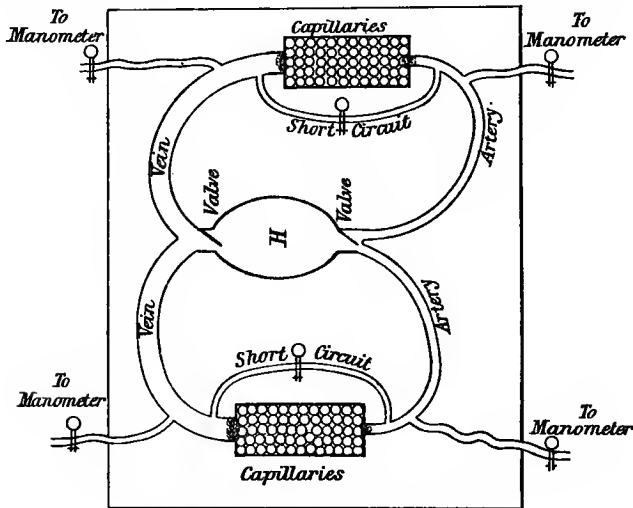

FIG. 133.—Artificial schema of the circulation.

of the velocity of flow, and inversely proportional to the sectional area of the vessel. In the arterioles the velocity is high, the total wall surface wet by the blood great, the sectional area of each arteriole very small.

In the schema the resistance is increased by diminishing the sectional area of the arterioles and increasing the velocity of flow. Owing to the resistance to the outflow the arteries are expanded by each systolic output, and the elasticity of their walls comes into play, causing the outflow to continue during the succeeding diastole of the heart. The larger part of the kinetic energy of the systolic outflow is stored up as potential energy by the stretched arteries, and converted into kinetic energy during diastole.

Stop the pump, the pressures in the manometers fall to the same level. Start the pump again. The fluid is taken from the vein and

piled up in the artery, for at each systole a greater quantity of blood is driven into the artery than can escape through the capillaries. With each succeeding systole, therefore, the pressure in the artery rises, and the pressure in the vein falls. Venous pressure cannot sink below the atmospheric pressure, for the flaccid walls of the veins collapse. The venous side is capacious, and possesses little elasticity. Thus the changes of pressure in the venae cavae, when the heart is arrested or starts beating, are insignificant. A slight positive pressure is maintained in the veins by the action of the muscles, which, at every movement of

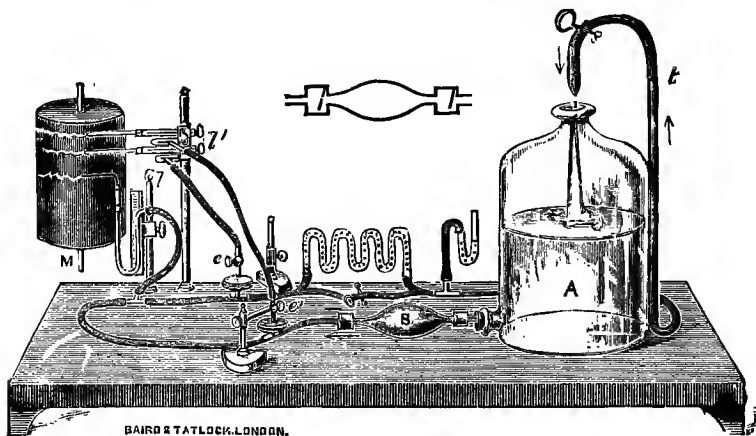

BAIRD & TATLOCK, LONDON.

FIG. 134.—Another model of artificial schema of circulation.

the body, forces the blood on past the venous valves and overcomes the effect of gravity. Raise the end of the board to which the pump (heart) is attached. The water under the influence of gravity distends the lower part of the vein, the upper part empties, and the circulation is impossible. Compress the lower part of the vein with your hands and the circulation is restored. This shows the effect of relaxation of the muscles in fainting and the method of restoring the subject by compressing the abdomen.

The continuous flow of blood established through the capillaries is due to the difference between the pressure in the arteries and veins. This difference depends: on (1) the energy of the heart, (2) the elasticity of the arteries, (3) the peripheral resistance. The energy of the heart is spent in overcoming the resistance, and is dissipated into heat.

Vary (1) by lessening the rate of the pump; vary (2) by opening the screw-clip—the difference in pressure diminishes in either case, and the flow becomes intermittent. When the screw-clip is open a

very frequent beat of the pump is required to make the flow continuous, and scarcely any fluid passes through the capillary tube. By means of the vaso-motor nerves the arterioles are similarly dilated or constricted, and the current switched on to or off an organ, according to its functional activity.

Velocity of Flow.—(1) Insert the Ludwig stromühr (Fig. 135) into the artery. It is convenient to fill one side with water, and leave the other full of air. In actual practice one tube is filled with defibrinated blood and the other with oil. Set the pump going, and find the number of times the stromühr must be turned per minute. Turn rapidly the moment the water reaches the mark X. Each turn means the flow of the quantity of water contained in one half of the stromühr. Measure the capacity of the stromühr and the diameter of the artery. The capacity of half the stromühr multiplied by the number of revolutions gives the volume, and this divided by the time and the sectional area of the artery gives the mean velocity per second. The sectional area of the artery equals the radius $\times 3.14$.

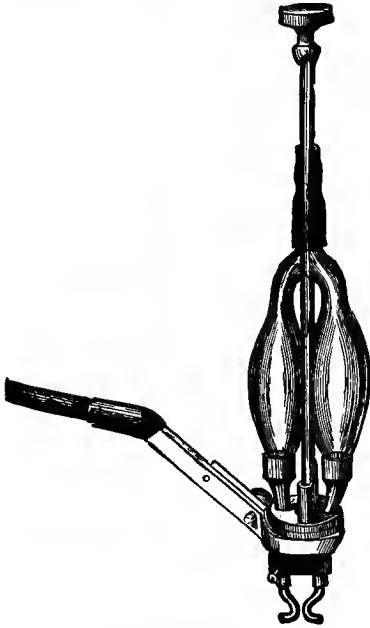

FIG. 135.—The stromühr.

Note the effect on the velocity of (1) opening the clip on the rubber tube, (2) of increasing the frequency of the pump.

If the energy of the heart is constant, then in proportion as the peripheral resistance increases so the lateral pressure rises and the velocity in the aorta lessens. On the other hand, as the peripheral resistance decreases the pressure falls and the velocity increases. If the peripheral resistance be constant, then as the energy of the heart increases or decreases both the pressure and the velocity in the aorta together become greater or less. By compensatory changes taking place in the heart and the resistance, the velocity may remain constant while the pressure varies, or the pressure may remain constant while the velocity varies.

The average velocity at any part of the vascular system is inversely

proportional to the total cross section at that part. If the total cross section of any one part of the circuit be dilated the velocity becomes slower there, while it proportionately increases in the other parts. This must be so if the blood continues to circulate round the whole system in the same time. Vaso-dilatation in one part is normally compensated for by constriction in other parts.

Velocity in the Capillaries.—Pith the cerebrum of a frog and plug the hole. Lightly curarise the frog, and spread the web over the hole in the web-board. Examine the circulation under the microscope, and with the aid of an ocular micrometer and a clock beating $\frac{1}{5}$ seconds measure the time it takes for a red corpuscle to move through $\frac{1}{100}$ mm. Note in an arteriole that the red corpuscles move the fastest in the axial stream, while the white corpuscles roll slowly along the margin.

Place on the web a drop of hot water (50° – 60° C.). The flow at first is accelerated owing to vaso-dilatation, but soon slackens as the red corpuscles clump together owing to the escape of the plasma through the damaged capillary walls.

The Influence of Gravity on the Circulation of the Snake.—Pith the brain of a grass snake or eel. (This experiment can be carried out on the frog, but is less striking.) Fasten the animal on to a board. Expose the heart, which may be seen beating beneath the skin, about 2-3 inches below the mouth. Place the animal head down in the vertical position. Notice the pericardium prevents the over-distension of the heart by the weight of the super-incumbent column of blood. Slit open the pericardium and observe the result. The heart becomes greatly congested. This is especially marked in the eel, when reflexly excited to writhe. Turn the animal head uppermost. The heart gradually empties, and becomes at last pale and bloodless. Slowly tilt the board and observe the blood as it runs up the inferior vena cava and fills the heart. Place the animal again in the vertical posture (head up), and observe that the heart fills (*a*) on compressing the abdomen from below upwards (*b*) on sinking the animal in a bath of water up to the level of the heart. In (*b*) the weight of the water outside tends to balance the weight of the blood within.

The vagus nerve may easily be found at the side of the neck in the snake, and the effect of its excitation noted. In the eel reflex inhibition of the heart is very easily brought about by striking the abdomen or gills.

Demonstration of Vaso-Motor Nerves.—A white rabbit is chosen, or one with a white ear; the brain of the animal is pithed and

artificial respiration established at once; a tube is put into trachea and connected with a small hand bellows; the ear is shaven and fixed by threads to a loop of stout wire. This wire is clamped in front of the lantern, so that the blood vessels in the ear can be plainly seen. The cervical sympathetic is exposed in the neck, where it lies behind the carotid artery, and is traced up to the superior cervical sympathetic ganglion. The thread is tied round the nerve, and the latter is cut. Observe that at this moment the blood vessels in the ear dilate and the ear becomes warmer. The palpebral fissure at the same time becomes narrowed. The change will be much more marked had the ear of the rabbit been previously exposed to cold. The cervical sympathetic exercises a tonic action. On exciting the peripheral end of the nerve with the faradic current, the vessels in the ear will be seen to constrict, and this will take place to such a degree that all the smaller vessels will disappear from view. The ear will at the same time become several degrees cooler. Note that the latent time is considerable between the excitation and the effect. Note that the pupil also dilates, the nictitating membrane retracts, and the palpebral tissue is widened. The eyeball at the same time projects forwards. The pupillo-dilator fibres arise from the first three thoracic anterior roots, the vaso-constrictor fibres from the second to the fifth, and even to the seventh, in the rabbit. If the superior cervical sympathetic ganglion be painted with nicotine, excitation of the preganglionic fibres will no longer have any effect on the ear, while excitation of the post ganglionic fibres will still be effectual. The sympathetic fibres to the head have their cell-stations in this ganglion.

The Circulation Time of the lesser Circulation.—The carotid artery is exposed. A piece of thin rubber membrane is placed beneath it. Between the membrane and the artery a piece of white paper is inserted. The artery is illuminated by a strong light.

The external jugular vein is exposed on the other side of the neck, a clip is placed on the vein below and it is tied above, and into its central end a cannula is inserted. The vein cannula is connected with a glass syringe containing a 0.2 per cent. solution of methylene blue in physiological saline at body temperature. Put a screw clip on the piston so that one-third of the contents shall be ejected. The clip is removed from the vein and at a signal from the assistant who times the experiment the syringe is pressed. The stop-watch is stopped by the assistant the moment the blue appears in the artery. The observation is repeated several times with the same amount of injection.

Demonstration of Arterial and Venous Pressure by the Method of Stephen Hales.—An incision is made in the mid-line of the neck, from the larynx to the sternum of the anaesthetised cat. The skin-flaps are pulled apart, and the sterno-mastoid and sterno-thyroid muscles separated, so as to expose the carotid artery. With an aneurism needle the artery is freed from the carotid sheath for the space of about an inch. Two ligatures are then placed beneath the artery, and one is tied at the upper end of the exposed portion. On the lower end an artery clip is placed. With sharp scissors an oblique cut is next made into the artery, and the nozzle of the arterial cannula is inserted, and tied in with the second ligature. Lastly the ends of this ligature are brought round the bulb of the cannula, and tied to make the connection secure.

The arterial cannula is **└** shaped and provided with a bulbous enlargement. This shape is chosen both to hinder clotting and to

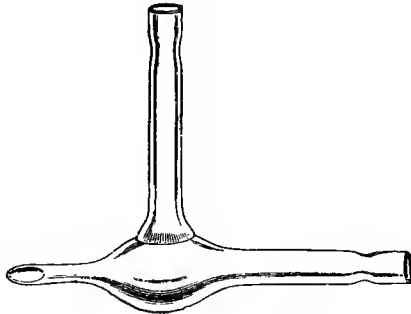

FIG. 136.—Arterial cannula.

facilitate the washing out of clots. One limb of the **└** is fitted with a short piece of rubber tube, and this is closed by a piece of glass rod or a clip. The other limb is connected by a short length of thick rubber tube (pressure tubing) to a long length of fine bored glass tubing. The latter must be at least 5 feet in length, and is held in the vertical position by a clamp. The glass tube and cannula are filled with 1 per cent. sodium citrate, and this decalcifies the blood and so prevents clotting. The solution is coloured with methylene blue, and a long strip of white paper scaled in centimetres is placed behind the tube.

By cutting through the attachment of the sterno-mastoid muscle, the junction of the jugular with the subclavian veins is next exposed. The innominate vein is picked up and cleaned with the aneurism needle. Two ligatures are placed under it, and a clip on the part nearest the

heart. One of the ligatures is tied round the junction of the jugular and subclavian veins. As the vein is clipped before the ligature is tied, it becomes distended with blood, and this facilitates the introduction of the cannula. The straight vein cannula is connected with a short length (1 foot) of glass tubing. The latter is clamped in the vertical position, and is filled with sodium citrate solution. The cannula is also filled with sodium citrate solution, and to retain the solution a clip is placed on the rubber tube, which connects the cannula with the glass tube. The positive pressure in the glass tube must not be more than 3 to 4 inches of the solution.

The innominate vein is now slit and the cannula introduced. Then the clip on the vein is removed, and the cannula is pushed down into the superior vena cava. The clip on the rubber tube is next opened so as to place the venous cannula in connection with the vertical tube. The fluid in this will now oscillate with each respiration at a level of about 2-3 inches. The clip on the artery is next opened. The fluid in the arterial tube will oscillate at a height of about 4 to 5 feet. Notice in each tube the cardiac pulsations and respiratory oscillations. The arterial pressure rises in inspiration—the venous in expiration.

1. If the abdomen be compressed the pressures will rise in both the artery and vena, but to a greater extent in the former. The heart is better filled in diastole and the peripheral resistance is increased by the compression of the splanchnic vessels.

2. If the thorax be squeezed so as to compress the heart and prevent its filling, the arterial pressure will fall very greatly, while the venous pressure will rise slightly.

Record of Arterial Pressure, Effect of Excitation of the Vagus and Depressor Nerves. Effect of Gravity. Effect of Asphyxia.—The artery is now clipped, the cannula washed out, and is connected to a mercurial manometer by a piece of pressure tubing, a L piece being interposed. The cannula and tube are filled by means of a pressure bottle or syringe with sodium citrate 1 per cent. solution, and the pressure in the manometer is raised to about the arterial pressure. The vagus nerve is exposed, ligatured in two places, and divided between the ligatures. The depressor nerve is exposed, ligatured, and divided below the ligature. The depressor in the cat runs separately from the vagus on the left side. On the right side it can generally be separated from the rest of the vagus without much difficulty. In the rabbit the depressor runs separately on both sides. In the dog it is bound up in the vago-sympathetic trunk.

The trachea is opened and a tracheal cannula inserted. This is connected with the anaesthetic bottle and by a side tube with a recording

tambour. The writing styles of the manometer float and of the tambour are brought to write on the kymograph exactly beneath one another.

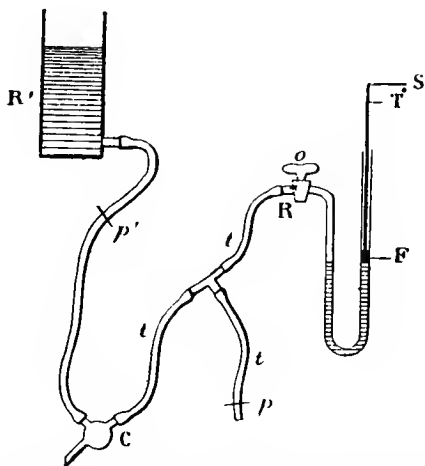

FIG. 137.—Arrangement of cannula, pressure bottle, and mercurial manometer for recording blood pressure. C, cannula; p, p', clips; F, float; S, writing style.

A clock marking seconds and an electric signal placed in the primary circuit are also brought to write on the kymograph. The primary circuit is arranged to give tetanising shocks, and shielded electrodes

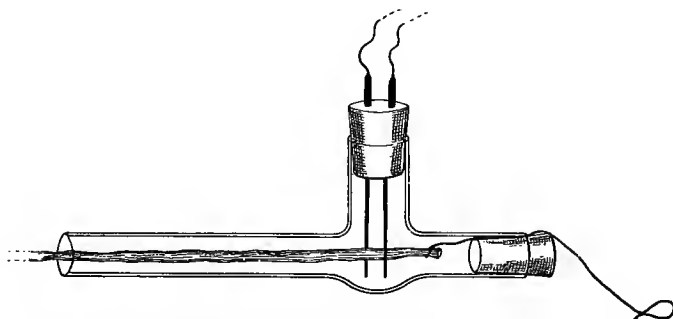

FIG. 138.—Electrodes for exciting vagus and other nerves. (Sherrington).

are connected with the secondary coil by means of a Du Bois key, and are placed in position under the peripheral end of the vagus nerve. The clip is then removed from the carotid artery and the kymograph started. Note the height of the arterial pressure, the cardiac pulsations,

and the respiratory oscillations of arterial pressure. The pulsations are distorted by the momentum of the mercury.

The inspiratory fall of intra-thoracic pressure aspirates blood into the intra-thoracic veins and thin walled auricles, and dilates the

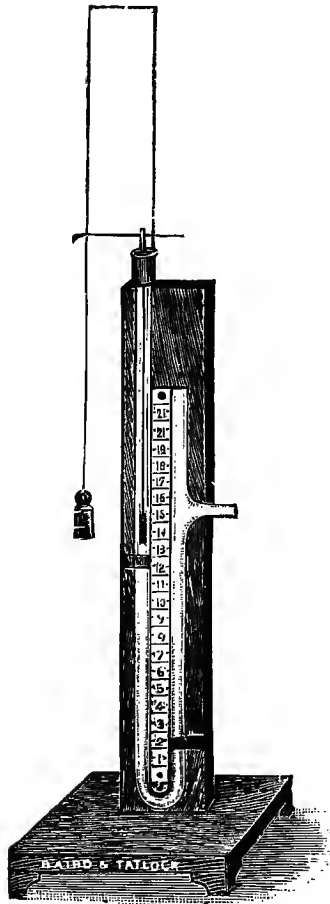

FIG. 139.—Mercurial manometer fitted with float and writing style.

pulmonary vessels. The descent of the diaphragm expresses blood from the liver and abdominal vessels into the right heart in the living animal. Thoracic and abdominal breathing have a contrary effect. Thoracic breathing produces an inspiratory fall of arterial pressure, and abdominal an inspiratory rise.

Stimulate the peripheral end of the vagus nerve. The heart is inhibited, and the arterial pressure falls. Complete arrest cannot be obtained in the cat. It is easily obtained in the dog. In the chloroformed dog with *low* blood-pressure, vagus excitation, produced by inhalation of concentrated chloroform vapour, may arrest the heart

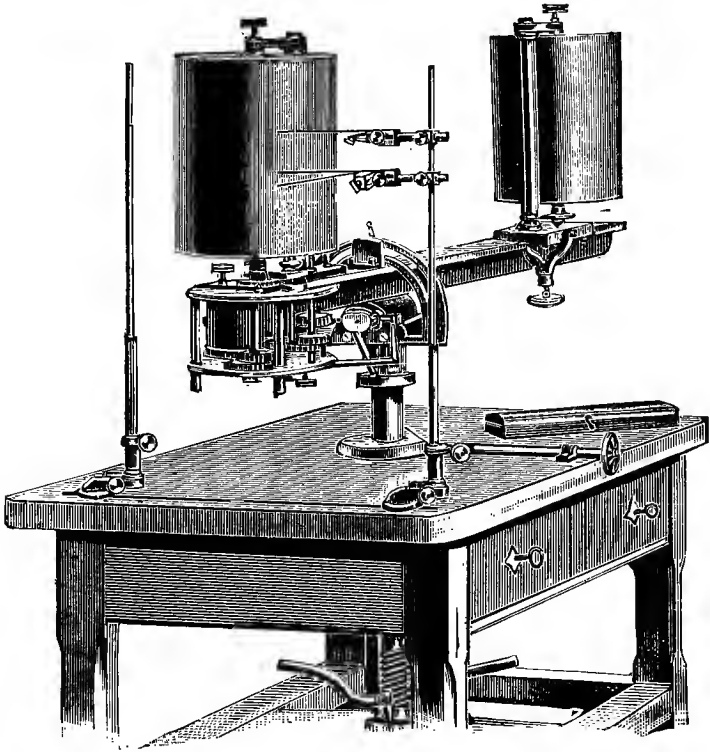

FIG. 140.—The kymograph.

for so long a period as to kill the animal. This is one cause of chloroform syncope in man. The heart soon escapes from vagus arrest if the blood pressure is high. The pressure (after vagus inhibition) for a brief space of time rises to a higher level.

The electrodes are now transferred to the central end of the vagus. Excitation produces either a slight rise (pressor effect) or a slight fall (depressor effect) of pressure. The heart rate is reflexly slowed, and the respiration is stopped with the diaphragm in inspiratory spasm.

The electrodes are next transferred to the central end of the

depressor nerve. On excitation the blood-pressure slowly falls, and remains at a lower level so long as the excitation is maintained. The rhythm of the heart is as a rule unaffected. The second vagus nerve is now exposed and divided. The heart accelerates, and the arterial

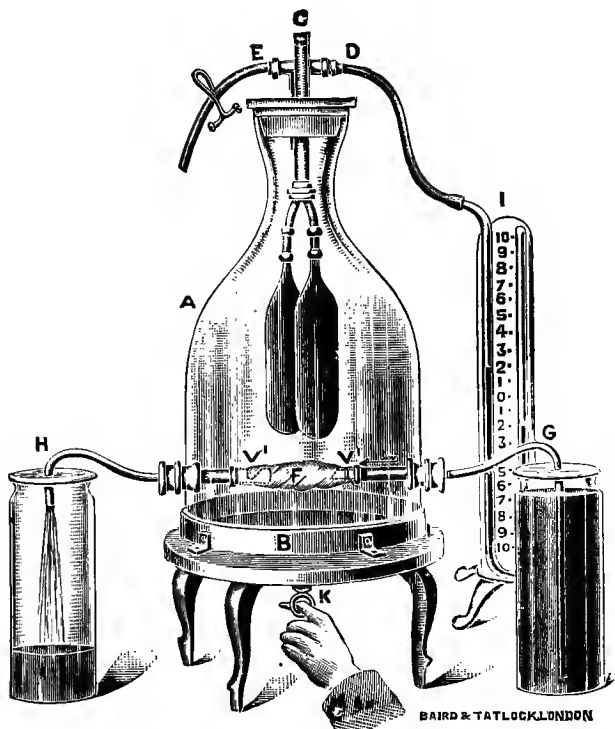

FIG. 141.—Hering's apparatus for demonstrating the action of the respiratory pump. A, Glass bell, thorax; B, air-tight base; K, diaphragm; C, trachea leading to lungs; I, manometer; E, tube opening into A; F, heart with valves V. The action of the diaphragm pumps air in and out of the lungs and water through the heart. The lungs and heart are thin rubber bags.

pressure rises. This is very marked in the morphinised dog. The vagus centre tonically controls the rhythm of the heart.

The Effect of Posture.—The animal is placed on a swing board, with the arterial cannula in the axis of rotation. A swing board can be improvised thus: through two staples on the under surface of the board on a level with the point of insertion of the carotid cannula, an iron rod is passed and the end of this clamped to two stout retort stands. On dropping the animal into the vertical posture, with the head up, the arterial pressure falls. It may rise again to, or even beyond, the

normal level in the cat. In the hutch rabbit the pressure falls, until the medullary centres become paralysed from anaemia. The weight of

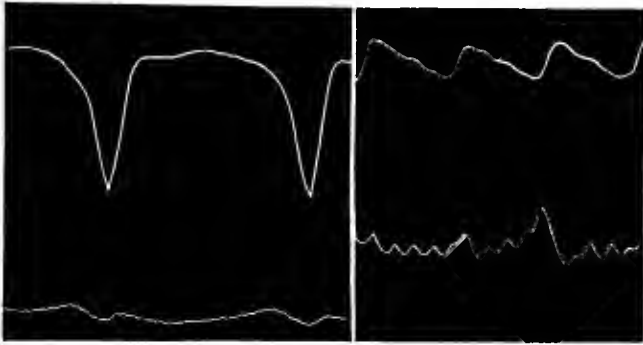

FIG. 142.—Record of arterial pressure and respiration (A) before and (B) one minute after dividing the vagi. The upstroke marks inspiration. The arterial pressure rose from 150 to 180 mm., the pulse rate from 110 to 260. Respiration fell from 24 to 10. The expirations became strenuous. (Burdon Sanderson.)

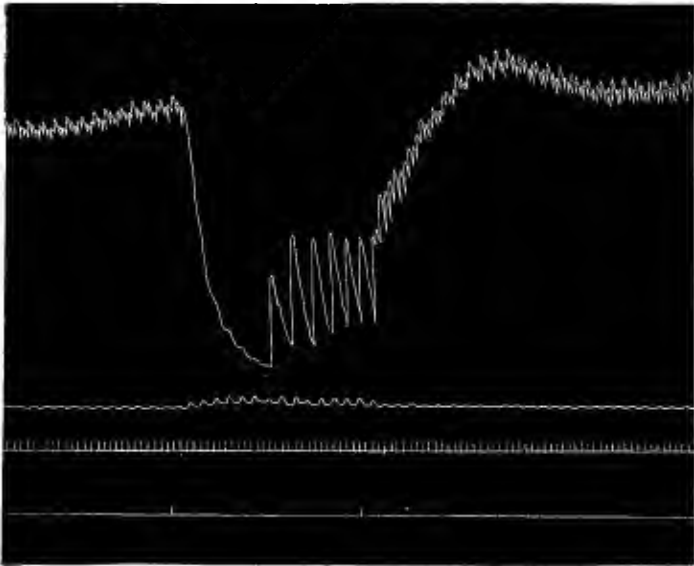

FIG. 143.—The effect of excitation of the peripheral end of the vague nerve upon the blood pressure in the aorta (top curve) and the vena cava (second curve) of a curarised animal with artificial respiration. Note the inhibition of the heart; the great fall of aortic and the insignificant rise of vena cava pressure; the escape of the heart from the vagus action and the after effect on the aortic pressure. The time is marked in seconds, and the signal line shows the duration of vagus stimulation. (L.H.)

the blood in the vertical posture is supported by the taut skin, the tone of the skeletal muscles, and the tone of the arterial system.

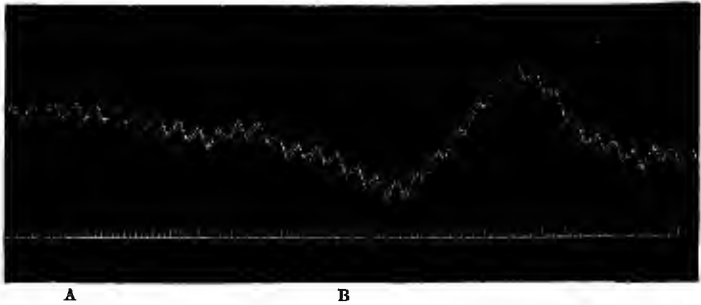

FIG. 144.—Aortic blood pressure. A, Effect of exciting the central end of vagus. The effect was depressor. B, On shifting up the electrodes to a fresh unexposed part of the nerve the effect changed to pressor. The time is marked in seconds. (L.H.)

The blood is largely returned to the heart by the action of the skeletal muscles, aided by the valves in the veins, and the respiratory pump.

If the spinal cord be divided in the lower cervical region, or the

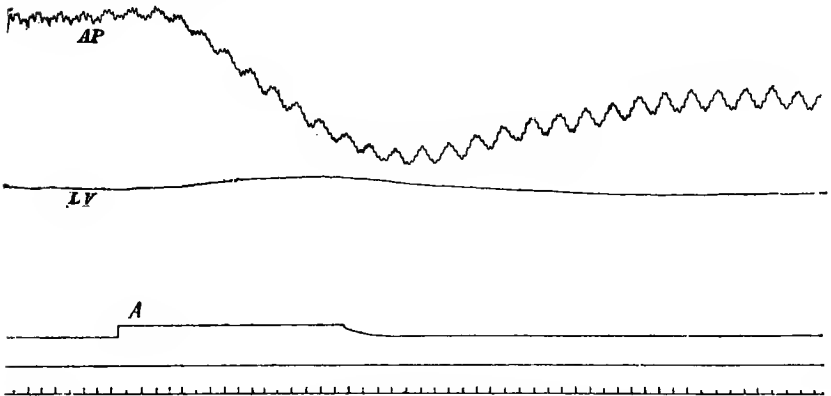

FIG. 145.—Record of arterial pressure (*AP*) and plethysmogram of limb (volume record *LY*). Excitation of the depressor nerve at signal *A*. The limb expanded in spite of the fall of arterial pressure. The time is marked in seconds. (Bayliss.)

administration of chloroform be pushed, these mechanisms are paralysed, and the blood congests in the lower parts, and the heart fails to fill. In such case the circulation is immediately restored by placing the animal in the horizontal posture.

Asphyxia.—The trachea is clamped. Note the sequence of events.

1st stage: Respirations deeper and more ample; heart accelerated and

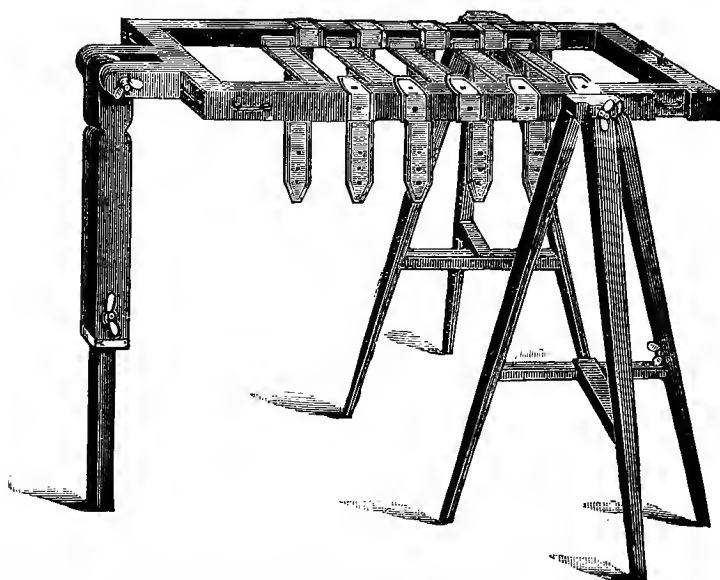

FIG. 146.—Hill's animal table. The table can be raised or lowered at one end, or be reversed.

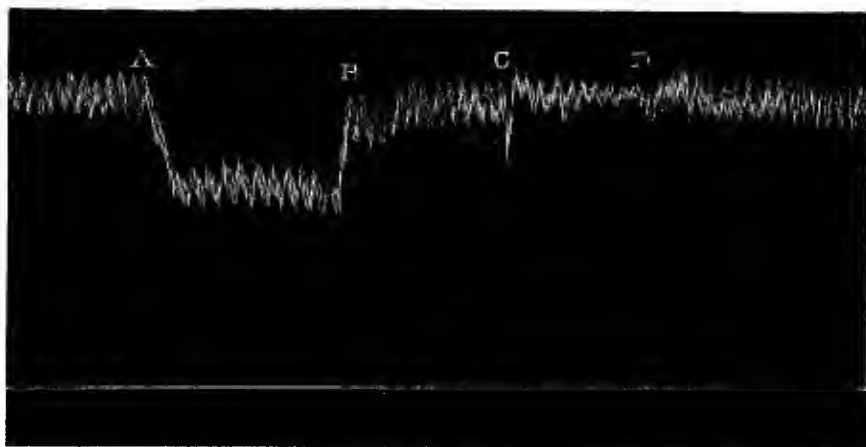

FIG. 147.—Aortic blood pressure. Effect of posture. A, Vertical head up; B, horizontal; C, vertical head down; D, horizontal. (L.H.)

more forcible. In the normal animal loss of consciousness now occurs and convulsive movements.

2nd stage: Respiration convulsive, less frequent; blood pressure rising; heart slow. At the end of the second stage the pupils dilate and emission

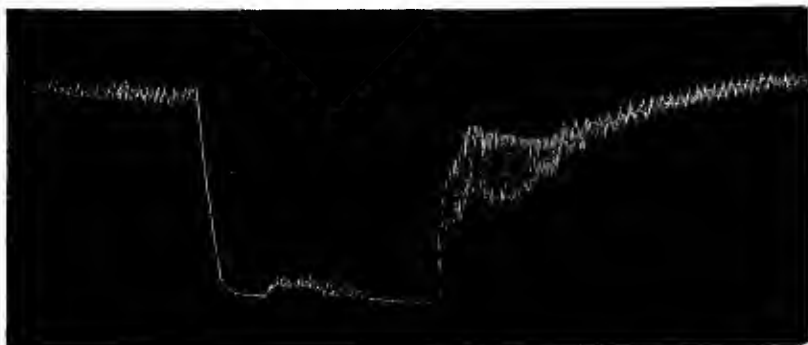

FIG. 148.—Aortic pressure. Spinal cord divided in upper dorsal region. Effect of placing animal in vertical head up posture. The heart emptied. On the return to the horizontal posture the circulation was restored. (L.H.)

takes place of urine and faeces. The veins are congested with black blood.

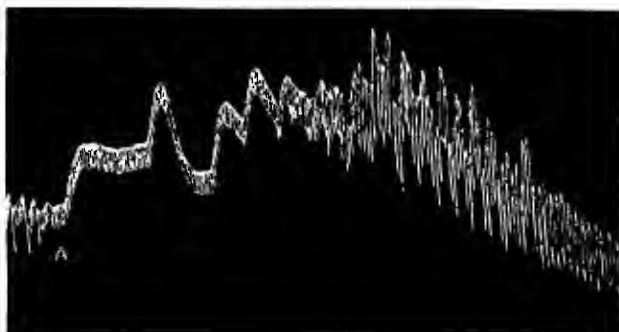

FIG. 149.—Arterial pressure; effect of asphyxia. Animal anaesthetised and curarised. At A the artificial respiration was stopped. The large oscillations are Traube-Hering curves. (L.H.)

3rd stage: The inspirations, which have occurred at longer and longer intervals, finally cease. The heart beats slowly and with great force. Finally the heart accelerates, and the blood pressure falls to zero.

CHAPTER XXXV. (*Advanced*).

THE HEART.

The Contraction Curve and Latent Time of the Stanniused Heart.—Expose the heart of a pithed frog. Pass a ligature under the two aortae, and draw the ends exactly round the white crescentic line which marks the sino-auricular junction. Tie the ligature. The sinus continues to beat, while the auricles and ventricles stand still. Record the heart by the suspension method.

Two needle electrodes passed through a piece of cork are pinned in such a position that one touches either side of the heart. The drum is set at a moderately fast rate, and the trigger key is placed in the primary circuit. A short circuiting key is placed in the secondary circuit, and the coil is arranged to give a break shock just perceptible to the tongue. Close the short circuiting key, and set the drum so that the striker is just beyond the trigger key. Then close the latter. Place the lever at a tangent to the drum, and bring the writing point lightly in contact. Then open the short circuiting key and start the drum. Stop the drum immediately after recording the contraction. Close the short circuiting key, then close the trigger key; lastly open the short circuiting key. Bring the

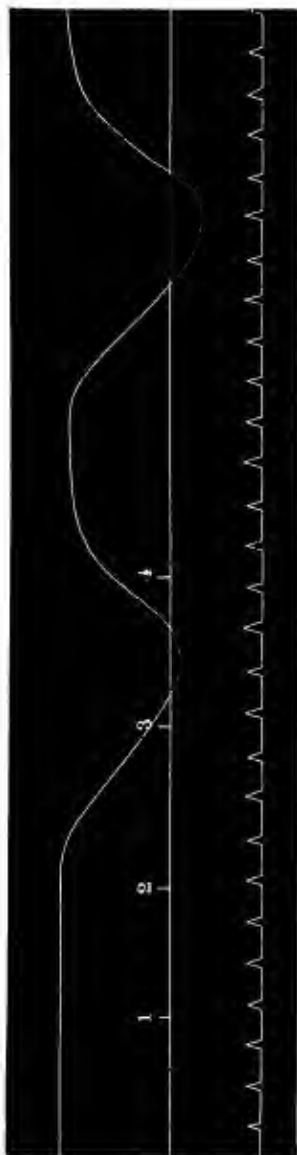

FIG. 150.—Record of contractions of a Stanniused heart. Excitations were given at the points marked 1, 2, 3, and 4. The second and third stimuli during systole were ineffectual. The fourth stimulus excited a second contraction. The contraction is represented by the down stroke. The time is marked in fifths of a second. (L.H.)

drum round slowly by hand until the striker just opens the trigger key. The heart will contract and the lever write a line marking the moment of excitation. Take another curve with the electrodes placed on either side of the base of the ventricle. The latent period will be less. In the first case the excitatory wave was delayed in the auriculo-ventricular groove. With the tuning fork (100 per sec.) take a time tracing just beneath the heart curves, and measure the latent period. It equals about 0.1 sec. The periods of contraction and relaxation will together last 2 sec. The contraction is much slower than that of striated muscle.

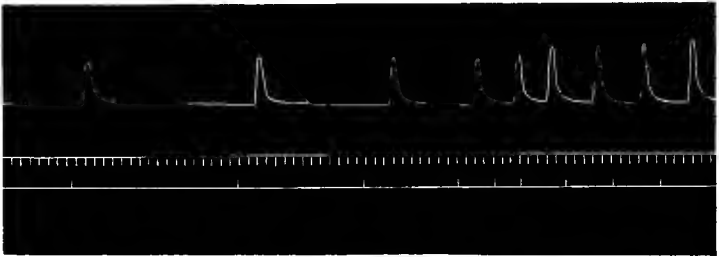

FIG. 151.—Stanniused heart. Staircase effect produced by excitations at the points marked on the lowest line. The time is marked in seconds. (L.H.)

Any Stimulus, if effective, causes a Maximal Contraction.—Place a spring key and an electric signal in the primary circuit. Set the drum at a slow rate and bring the heart lever and signal to write on the drum. Record the effect of excitation at intervals of a minute or more, with varying strengths of current. The heart gives ‘all or nothing,’ *i.e.* if excited at all it gives its full contraction.

The Refractory Period.—Record the effect of throwing in a second excitation (*a*) during the systole, (*b*) during diastole. The heart is *refractory* during the whole period of systole, *i.e.* it makes no response to a second stimulus. The excitability returns with diastole, and becomes greater as diastole proceeds. (Fig. 150).

Staircase Phenomenon.—A Stannius preparation is excited with single induction shocks once in every five seconds. The stationary drum is moved on by 2 mm. between the excitations. The heights of the first four or five contractions form an ascending series. The heart responds to any stimulus which is effective by a maximal contraction. The height of the contraction depends on the condition of the heart muscle, not on the strength of the stimulus, so long as the latter is effective. For the first few beats each contraction makes the heart more excitable. The same phenomenon is observed in the muscle

of curarised frogs with intact circulation, and also in the galvanometric records of the action current of nerve. Waller attributes the staircase effect to the influence of CO_2 formed by the katabolism of the active tissue.

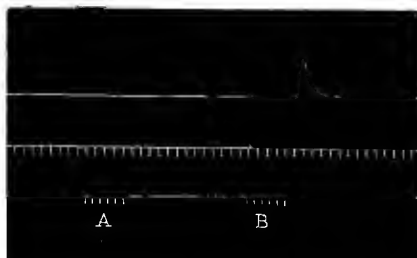

FIG. 152.—Stanniused heart. Summation of stimuli. A, ineffective, and B, effective stimuli. The time is marked in seconds. (L.H.)

Summation of Stimuli.—Pull out the secondary coil until the break shock is just ineffective, and rhythmically stimulate the Stannius preparation with this inadequate stimulus. The heart will respond to the repeated excitation, and the first few beats will show the staircase phenomenon.

CHAPTER XXXVI. (*Advanced*).

THE HEART—CONTINUED. THE ACTION OF DRUGS.

The Suspension Method of Investigating the Action of Drugs on the Frog's Heart.—Large frogs and great care are necessary for this experiment. Pass a ligature under the vena cava inferior, where it is joined by the hepatic veins and enters the sinus. Make a V-shaped incision, and tie in a fine glass cannula. The cannula must be provided with a rubber tube ending in a syphon tube. The tube is provided with a clip, and the whole is filled with Ringer's solution, which is contained in a flask. Attach a hook to the ventricle apex, and record the heart by the suspension method. A slit is made into the aorta. Open the clip, circulate the Ringer's fluid, and record a series of contractions. Now replace the flask of Ringer's solution with one containing distilled water.

1. 0.75 % NaCl solution in distilled water—followed by a Ringer or Locke's solutions until the normal beat is recovered.

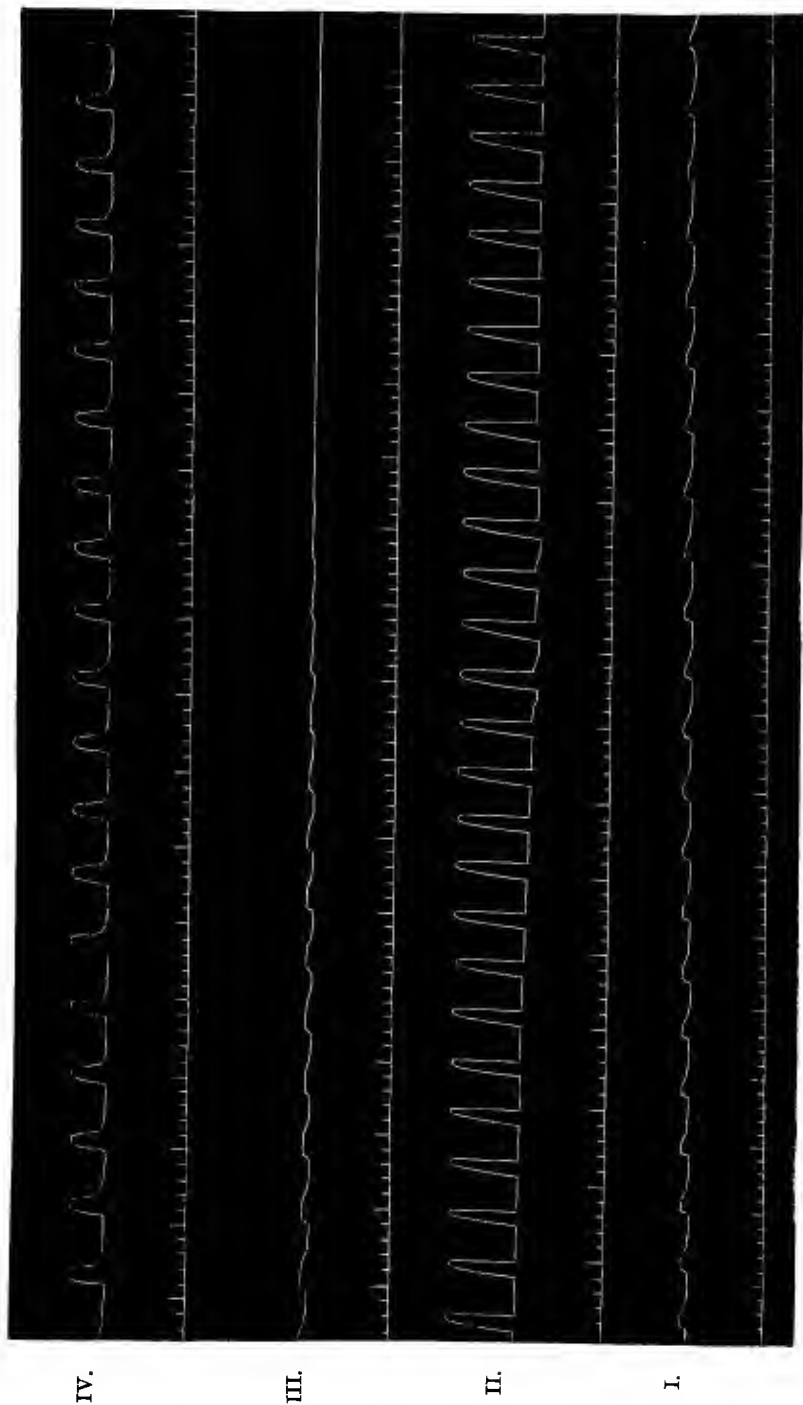

FIG. 158.—Contraction of the heart of the frog. I. Effect of distilled water. Temp. 16-25°. II. Contraction restored by normal tap-water saline. III. and IV. Repetition of the experiment. The time is marked in seconds. (Pembrey and Phillips.)

2. 0.75 % NaCl solution containing 0.3 % KCl (5 c.c. 7 % KCl solution in 100 c.c. 0.60 NaCl)—followed by Ringer or Locke's solutions until the normal beat is recovered.

3. 0.75 % NaCl solution containing a few drops of a 5 % solution CaCl_2 followed by Ringer or Locke's solution until normal beat is recovered.

4. Distilled water.

Water distilled in glass is less noxious than water distilled in copper or lead. Merely hanging a strip of copper foil in distilled water overnight increases its poisonous properties. It is calculated that there is not more than 1 part of copper in 70 million of the water. The heart is at first stimulated by sodium ions, but after some time becomes weaker, and finally stops in diastole. Tap-water contains traces of calcium salts, which are beneficial. Normal saline should therefore be made with tap-water. The calcium ions present in small quantities in the blood help to maintain contractility and irritability. Excess of calcium throws the heart into a contracted state—calcium rigour. Potassium ions in excess relax the heart and abolish excitability. Ringer's solution contains 0.7 % NaCl, 0.03 % KCl, 0.025 % CaCl, and keeps the heart in good state. A 2 per cent. solution of digitalin causes increased tone of the heart, vigorous systole, and incomplete diastole. The heart finally is arrested in a state of systolic contraction. Caffeine and veratrine also act tonically on the heart. Supra-renal extract, or adrenalin, at first slows and then increases the tone and the frequency of the heart. Adrenalin is the active principle of the medulla of the supra-renal gland. A solution containing 1 part in 10,000 constricts vessels of the conjunctiva.

Weak solutions of acid bring the heart into diastolic arrest. Alkalies produce systolic arrest.

CHAPTER XXXVII. (*Advanced*).

GASKELL'S CLAMP AND THE EFFECT OF LOCAL WARMTH ON THE HEART.

Gaskell's Clamp and the Effect of Heat on Sinus and Ventricle.—The heart of a large frog or toad is required. The contraction of the auricle and ventricle are registered by means of two levers which are

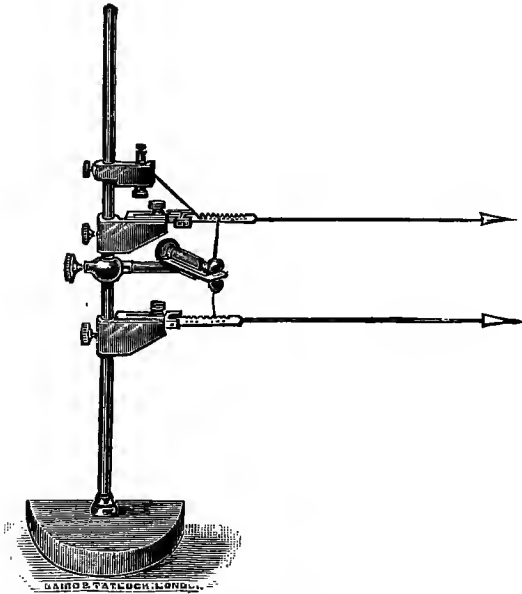

FIG. 154.—Gaskell's heart clamp and levers for recording the contraction of auricle and ventricle.

attached by means of threads to the apex of the ventricle and auricle respectively; the one lever is pulled downwards against an elastic spring and the other upwards. The heart is held fast by means of a screw clamp in the auriculo-ventricular groove.¹ The clamp is provided with a fine screw, which can easily be adjusted so as to hold the heart firmly without injuring the tissue (Gaskell). In this way the contractions of auricle and ventricle are registered separately. Take a thick copper wire, bent into a hook at one end, and place the hook round the sinus. Warm the other end of the wire in a flame.

¹ A screw clip, to the bars of which cork wedges are fastened, will do for the clamp.



FIG. 155.—Record of the contraction of auricle and ventricle (toad) by the use of Gaskell's clamp and levers. The upper tracing is the auricle and here the contraction is represented by the down-stroke. The time is marked in seconds. (L.H.)

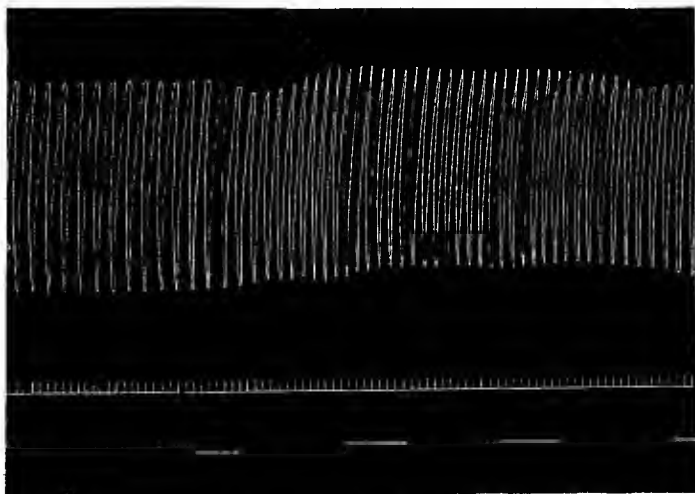

FIG. 156.—Record of the contraction of the toad's heart by the suspension method. Heat applied by the copper wire method. The signal in the third line shows the period during which the sinus was heated. Acceleration of the whole heart was produced. In this curve the down-stroke represents the contraction. The time is marked in seconds. (L.H.)

The result of warming the sinus is a great increase in the rapidity of the beats both of the auricle and ventricle.

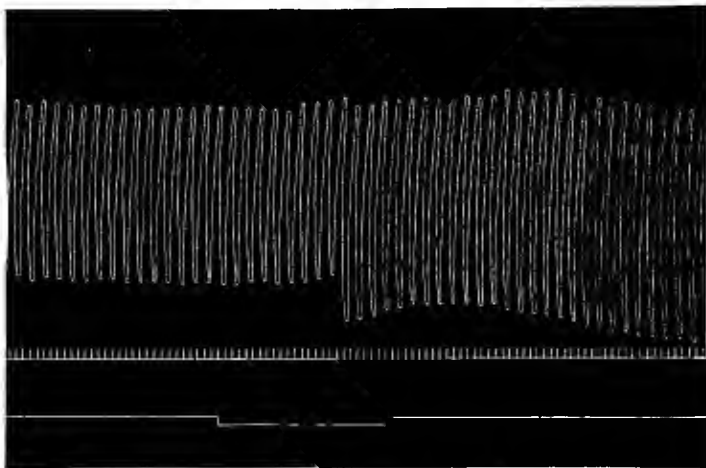

FIG. 157.—Continuation of Fig. 156. Ventricle heated. Augmentation of the ventricular contraction, but no change in frequency. (L.H.)

Now warm the ventricle in like manner. No alteration of rate of rhythm is produced by heating the ventricle, but each ventricular contraction is augmented.

The observation of the local effect of warmth may be carried out equally well on a heart recorded by the ordinary suspension method.

CHAPTER XXXVIII. (*Advanced*).

ACTION OF THE CARDIAC NERVES.

Dissection of the Cardiac Nerves in the Pithed Cat or Rabbit.—The cat has been instantly killed for you by pithing. Quickly tie out the legs of the animal to the nails on the board provided, and tie a string tightly round the lower jaw, and this to the nail at the head of the board. Pick up the skin over the neck between the fingers, and cut through it with scissors. Pick up the trachea between the fingers and incise it, and insert the tracheal tube, which is connected with the bellows which are kept working by the motor. Artificial respiration is thus set going. Separate the sterno-laryngeal muscles from the sterno-mastoid along one side of the trachea and expose the carotid sheath. Separate (Ca) the carotid artery: (P.n.) the vagus,

this is the largest; (Dep) the depressor, a fine nerve which may be traced up to where it arises by two branches, from the superior laryngeal nerve and from the vagus; (Sy) the cervical sympathetic, a slender thread, which may be traced up to the superior cervical sympathetic ganglion. In the cat vagus and sympathetic are one, and the depressor is separate on the left side only as

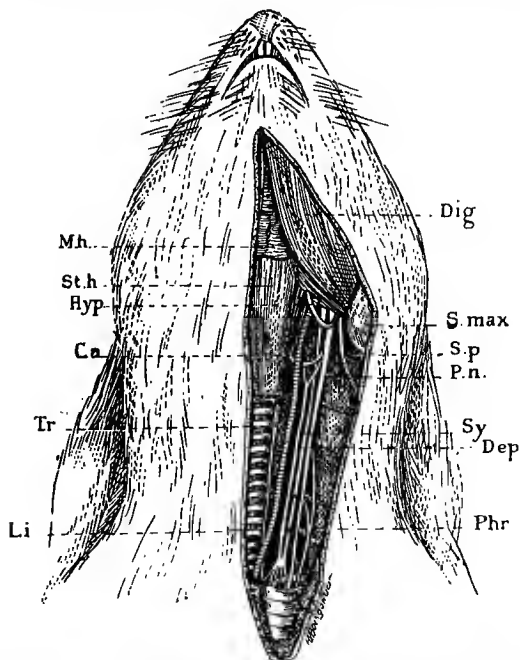

FIG. 158.- Dissection of the vagus, the depressor, and cervical sympathetic nerves in the rabbit. (Livon.)

a rule. Tie threads round these nerves, ready for their excitation. Pass two ligatures under the carotid, and tie the upper one. Put a clip on the artery below. Make a V-shaped incision, and insert and tie in the cannula. Connect the cannula with the mercury manometer by pressure tubing, and with the glass syringe fill the tube and cannula with a sat. sol. of Na_2SO_4 . Close the side tube of the cannula with a piece of rubber tube, in which a solid glass rod is inserted. Carefully raise the pressure in the manometer by means of the syringe to about 100 mm. Hg, and clip off the syringe. Open the clip on the artery, and record the blood pressure on the slow drum. Faradise the peripheral end of the vagus and observe the inhibition. Stop the artificial respiration for a short time, and observe the effect of asphyxia.

Next divide the skin over the upper part of the sternum and reflect the left skin flap.

Pass threads round the sternal ends of the left first and second ribs. Tie these and divide the ribs between the threads and the sternum. Pull the ribs outwards by means of the threads, separate the intercostal muscles with the knife, and by cutting through the spinal attachments of these ribs remove them.

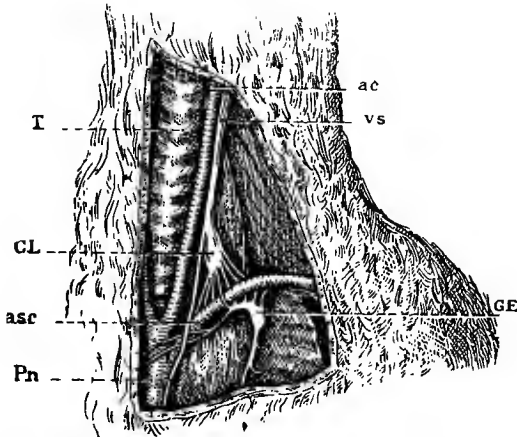

FIG. 159.—Dissection of the stellate ganglion (GE) and cardiac accelerators. The inferior cervical ganglion (CL) and vago sympathetic (vs) are also shown. (Pn) vagus; (ac) carotid artery; (asc) subclavian artery. (Dubois.)

The stellate or first thoracic ganglion may now be found and cleaned from the surrounding adipose tissue. It lies just in front of the spinal attachment of the first rib. Branches enter the stellate ganglion from the first, second, and third thoracic roots. Below the sympathetic cord is attached to it, and above a nerve passes to it from the 8th cervical root. The ganglion sends off branches, which form the annulus of Vieussens, and pass to the inferior cervical ganglion. From the annulus and from the inferior cervical ganglion branches pass to the cardiac plexus. The stellate ganglion is the cell-station of these accelerator and augmentor fibres.

The stellate ganglion is also the cell-station of the fibres which pass to the brachial plexus (vasomotor, pilomotor, sudoriferous) and to the vertebral artery.

The cervical sympathetic fibres pass through the ganglion, and have their cell-stations in the superior cervical sympathetic ganglion.

Excitation of the (1) cervical sympathetic dilates the pupil, retracts

the nictitating membrane, causes separation of pupils and projects the eye with the axis of the eyeball straight forwards.

It constricts the blood-vessels of the skin, glands, and mucous membrane of the head.

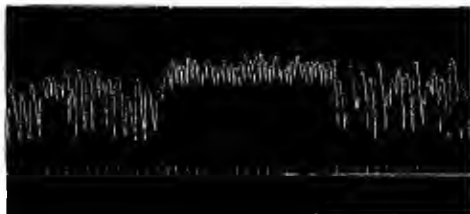

FIG. 160.—Arterial pressure. Effect of exciting the stellate ganglion (accelerato nerves). The time marked in seconds. (L.H.)

It dilates the vessels in the bucco-facial region of the dog.

It excites secretions of the glands of the head, both salivary and sweat glands.

It erects the hairs in the cat and monkey over certain regions of the face and scalp.



FIG. 161.—Record of arterial pressure. Cardiac acceleration produced by excitation of the third dorsal root during the time shown by the signal line. (Bradford.) The time is marked in seconds.

(2) The depressor nerve is an afferent nerve which runs from the heart to the spinal bulb, and causes general dilatation of the blood-vessels—especially in the splanchnic region. (See Fig. 145.)

It thus lowers the arterial pressure. The depressor is bound up with the vagus in the dog.

(3) The vagus is the inhibitory nerve to the heart, the motor nerve to the bronchial muscles.

It conveys both inhibitory and augmentary impulses to the alimentary canal.

It is a secretory nerve to the gastric glands and pancreas.

It contains afferent fibres from the heart which provoke reflex movements, pressor or depressor effects, and reflex cardiac inhibition.

The afferent fibres of the vagus coming from the lungs regulate the rhythm of respiration.

The superior laryngeal branch of the vagus is the motor nerve to the crico-thyroid muscles and the sensory to the larynx.

The inferior laryngeal branch is the motor nerve to the intrinsic muscles of the larynx.

Spinal Preparation of Mammal.—Sherrington employs the following preparation for studying blood pressure and spinal reflexes, action of vagus on heart, oncometry of kidney, action of nerves of bladder, etc. :

The animal (cat) being deeply anæsthetised with chloroform, a cannula is inserted into the trachea. Both common carotids are ligated. A transverse incision through the skin is made over the occiput and extended laterally close behind the pinnae. The skin is retracted backwards so as to expose the neck muscles at the level of the axis vertebra. The ends of the transverse processes of the atlas are then felt for and a deep incision made through the musculature just behind these processes. The large spinous process of the axis is notched with the bone forceps. A strong thick ligature is passed by a sharp-ended aneurism needle close under the body of the axis and is tied tightly in the groove left by the incision behind the transverse processes of the atlas and the notch made in the spinous process of the axis. This compresses the vertebral arteries where they pass from transverse process of axis to transverse process of atlas. A second strong ligature is then looped round the neck at the level of the cricoid and is so passed as to include the whole neck except the trachea. Decapitation is then performed with an amputating knife passed from the ventral aspect of the neck through the occipito-atlantal space, severing the cord just behind its junction with the bulb. The ligature round the neck is drawn tight at the moment of decapitation. The severed head of the deeply narcotised animal is then destroyed. Haemorrhage is extremely slight. If there is oozing from the vertebral canal it is arrested by raising the neck somewhat above the rest of the carcase. The carcase is placed on a small metal-topped table warmed by an electric lamp below. Artificial respiration is employed to ventilate the lungs, the fresh air supplied from the bellows being warmed by passing through a chamber containing a small electric lamp. The skin flaps are stitched together, covering the exposed end of the spinal cord and other structures bared

by the amputation wound. The carcase will continue for several hours to exhibit good reflexes employing the skeletal muscles, although the arterial blood-pressure is low, often not more than 80 mm. Hg. The scratch and other reflexes may be studied very well on this preparation.

CHAPTER XXXIX. (*Advanced*).

THE PULSE.

The Velocity of Transmission of the Pulse Wave.—Mackenzie's polygraph is used. The recording tambours write on a roll of paper which is unwound by the clockwork. The writing styles are wet with red ink. A time marker writes seconds. Two tambour sphygmographs are taken, and one is applied to the carotid, and the other to the radial artery. The recording tambours are brought to write exactly beneath one another on a fast drum, and a time tracing is taken with the tuning fork. Mackenzie's polygraph is most convenient for these experiments. The distance between the carotid artery and the radial is measured. The rate of transmission is about 5.8 metres a second. The rate of transmission increases as the coefficient of elasticity of the arterial wall. It is therefore greater with high than with low arterial pressure.

The velocity of transmission from carotid to radial may be lessened by placing the arm in water so as to produce vaso-dilatation. The length of the pulse wave is the product of the velocity of transmission by the time occupied by the wave in passing any given point. Calculate this value from the record. It is about 5 metres, so the pulse wave reaches the periphery before it has left the aorta.

Jugular and Radial Pulse Curves.—The jugular pulse and the radial venous pulse are simultaneously recorded in man, and by this means time relations of the cardiac cycle are determined. The jugular pulse is recorded by means of a receiving tambour, which is pressed down upon the jugular vein just above the clavicle on the right side.

The tambour is not closed by a membrane, but is pressed down on the skin by the fingers until an air-tight junction is made and a good tracing is obtained. The subject must lie down with his head slightly raised by a cushion and bent to the right side. The venous pulse shows three positive waves, *A*, *C*, and *V*. *A* marks the auricular systole. *C* is synchronous with and chiefly caused by the output of blood from the ventricles into the arteries. The carotid

artery lying close by influences the venous trace. V is due to the filling of the auricle during the ventricular systole. The negative wave

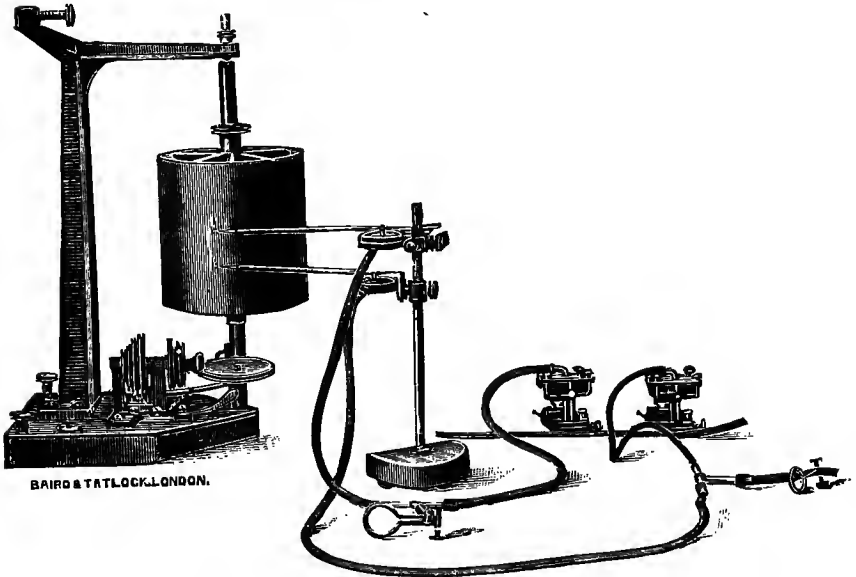

FIG. 162.—Tambour-sphygmographs arranged for measuring the velocity of transmission of pulse-waves.

after V is probably due to the rapid dilatation of the ventricle and entry of blood therein. The venous pulse and radial pulse taken simultaneously demonstrate whether the cardiac rhythm and

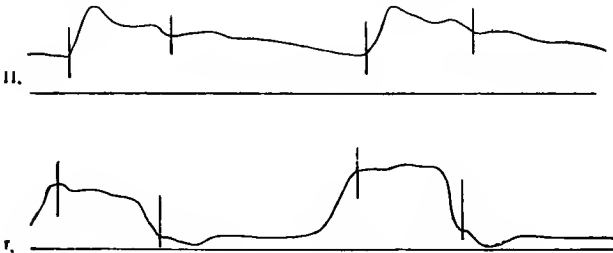

FIG. 163.—Impulse (I.) and pulse curves (II.) The vertical lines, marking the ascent of the pulse curve and the dicrotic notch, indicate the opening and closing of the semi-lunar valves.

sequence are normal. In pathological states extra systoles may occur, or the ventricle beat independently of the auricle with its own rhythm. Alterations in the auricle-ventricular bundle are

probably the cause of such disturbed action. While the record is being taken place both hands on the subject's belly and compress the abdomen ; both venous and arterial pressures rise. The rise in arterial pressure may be measured with the sphygmometer.

One tambour is now placed over the carotid and another over the cardiac impulse. The beginning of the impulse curve marks the beginning of the ventricular contraction. The beginning of the carotid pulse curve marks the beginning of the period of systolic output and the opening of the aortic valves. Between these points is the period of rising tension, when the ventricle is raising the blood pressure up to that in the aorta. The beginning of the dicrotic notch corresponds with the closure of the aortic valves and the end of output. The time lost in the transmission of the pulse-wave from the heart to the carotid artery should be deducted in making these time measurements, but it is almost negligible. In a man with a pulse frequency of 70 the duration of systole was 0.379 sec., of diastole 0.483 sec. It is interesting to repeat the observations after the frequency of the heart has been accelerated by running up and down stairs. The diastolic period is shortened much more than the systolic period. When the pulse varied in the proportion 100 : 270 the duration of a systole varied in the proportion 136 : 100.

With the two armlets and mercurial manometer and syringe bulb measure the systolic pressure in the arm and leg using the radial and posterior tibial or dorsalis pedis arteries as indices of the obliteration of the pulse. Let the subject be horizontal. Repeat after the subject has run up and down stairs, and again after he has put one hand in hot water for some minutes. The pressures which were equal will now appear unequal for the artery softened by the effect of heat conducts the pulse less well. In cases of aortic regurgitation the leg and arm readings are unequal, the leg being the higher owing to the leg arteries being stiffer and conducting the wave better. Measure the pressure in the leg and arm (1) with the subject lying horizontal, (2) with the legs raised in the L-shaped position, (3) standing erect, the observed leg being kept in an easy relaxed position and the weight thrown on the other leg. In each case measure the difference in height between the upper edges of the armlets with the metre rule. Calculate the difference in terms of mercury by dividing by 13, and compare the difference in the readings found with the calculated differences. The pressure differs by the column of blood separating the two points of measurement. The compensatory vasomotor mechanism keeps the pressure in the aortic arch and its branches about the same in all three postures, while the pressure in the leg arteries varies greatly.

CHAPTER XL. (*Advanced*).

VASO-MOTOR SYSTEM.

Innervation of the Blood-vessels.—Pith the cerebrum of a large frog and plug the hole with a blunt-pointed match to prevent haemorrhage. Curarise the frog lightly, place it on the cork board provided for studying the circulation in the web. Tie out the toes so as to spread the web over the hole in the board. Observe the rate of circulation. Next pass a pin through the occipito-vertebral membrane and destroy the spinal bulb. The circulation will become more rapid owing to dilatation of the arteries.

Now remove the frog from the board and expose the heart. Suspend the frog in the vertical head-up position. Note that the heart and large vessels are filled with blood. Pass a blanket-pin down the vertebral canal and destroy the spinal cord. The heart and vessels will soon become bloodless owing to the loss of vaso-motor tone. The blood sinks into the dilated abdominal vessels under the influence of gravity.

Perfusion of Frog's Blood-vessels.—Destroy the brain and plug the hole in the skull. Expose the heart. Tie one aorta. Place a ligature under the other, snip it with sharp scissors, and allow the blood to escape. Insert a fine-glass cannula into it pointing away from the heart. Fill the cannula with normal saline by means of a capillary pipette. Connect a rubber tube to a glass funnel and clip the tube. Fill the funnel and tube with Ringer's fluid. Connect the tube with the cannula. No air bubbles must be introduced. Snip the sinus venosus and open the clip. Hang the frog in the vertical position. The fluid circulates, runs out of the sinus, and drops from the toes of the frog into a measure glass. Measure the outflow per minute. Circulate Ringer's fluid plus 1 in 1000 sodium nitrate; the outflow is increased owing to vaso-dilatation. Supra-renal extract produces the contrary effect.

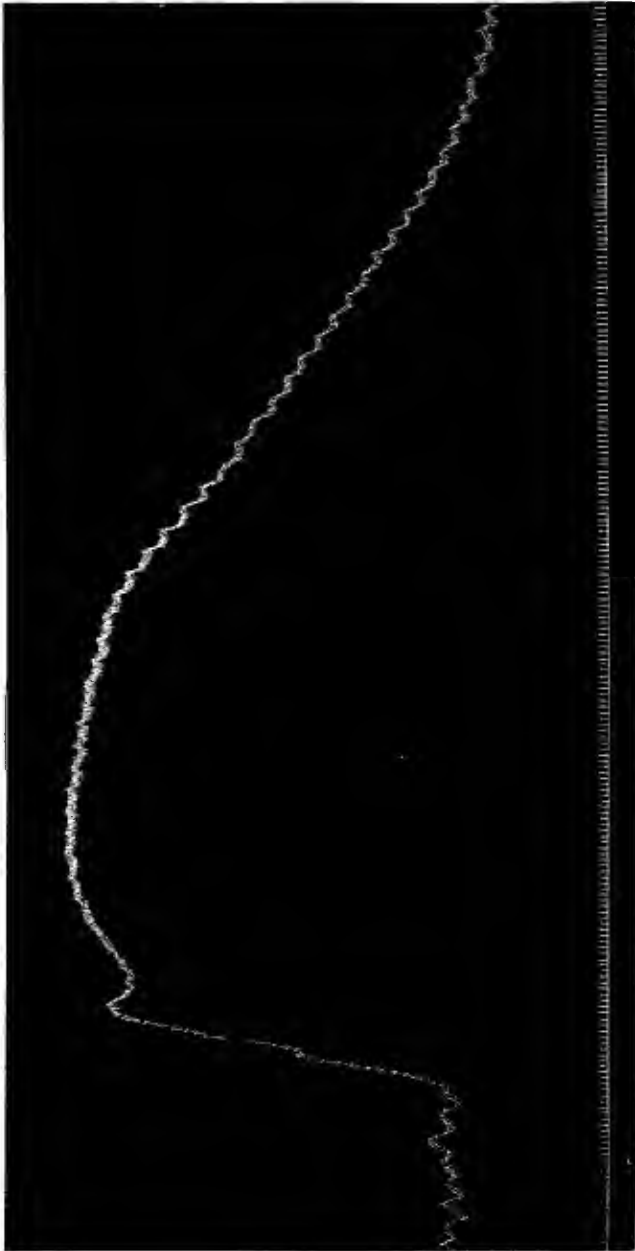

FIG. 164.—Arterial blood-pressure of cat. Effect of injecting supra-renal extract. The time is marked in seconds.

CHAPTER XLI. (*Advanced Demonstrations*).

INTRACARDIAC PRESSURE. BLOOD FLOW.

Intracardiac Pressure.—Owing to inertia the mercurial manometer is unable to respond to the rapid changes of intracardiac pressure. The pulse curves obtained by the mercurial manometer are also distorted by the swings due to the momentum of the mass. To record the changes of intracardiac pressure an instrument must be contrived which is able to follow a change of pressure equal to 1500 mm. Hg per second.

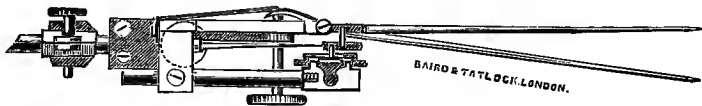
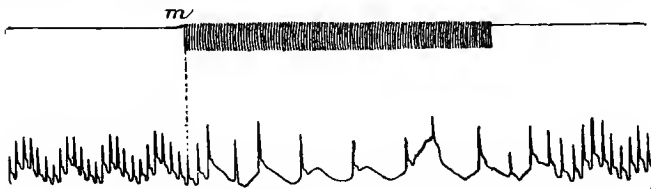

FIG. 165.—Hürthle's spring manometer.



FIG. 166.—Sphygmoscope.

Hürthle's spring manometer consists of a small tambour, 5·5 in diameter, covered with rubber membrane. A button attached to the membrane works against a steel spring. The movement of the spring is magnified by a light lever. Inertia is proportional to the mass and the square of the velocity. By making the tambour very small and the lever very light the errors due to the inertia of the fluid and lever are reduced to a minimum.

FIG. 167.—Arterial pressure recorded by a spring manometer. Effect of weak excitation of the vagus during the period marked by the signal *m*. (Dubois).

The sphygmoscope is an equally good instrument. One end of a rubber finger-stall is drawn over the end of a rubber cork. The cork is inserted into a short piece of wide tube. A glass tube passes through this cork into the small air-space which is left at the top of the finger-stall. The other end of the wide tube is closed by a rubber cork. A

glass tube passes through this cork and is connected with a recording tambour. The finger-stall acts as the spring.

Connect by side tubes the mercurial manometer and the Hürthle manometer with the artery in the artificial schema. Take records

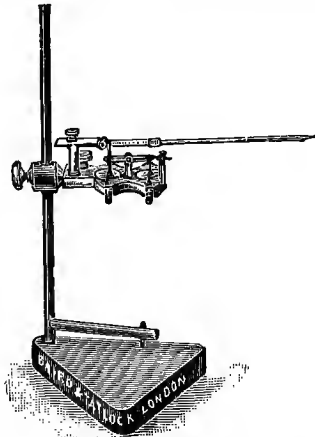

FIG. 168.—Hürthle's differential manometer.

with each instrument on a moderately fast drum, and compare the results. Connect by side tubes one side of the Hürthle differential manometer with the chamber of the pump, and the other side with

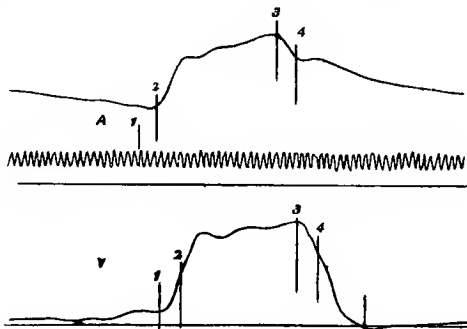

FIG. 169.—Aortic and ventricular pressure curves taken by Hürthle manometers. (Hürthle).
 1. Beginning of systole. 2. Opening of semilunar valves. 3. End of rise of ventricular pressure. 4. Dirotic notch, closure of semilunar valves.

the artery close to the valve. Take a record, and observe how the instrument records the moment when the valve opens and shuts. If a time tracing be taken, the time relations of the pump (ventricular contraction) can be exactly determined. The period of ventricular

systole is divided into three: (1) the period of rising tension, when all the valves are closed; (2) the period of output; (3) the period of relaxation. In simultaneous records of intra-ventricular pressure and aortic pressure the beginning of the aortic rise (2) marks the opening of the aortic valve and beginning of output. The end of output occurs when the semilunar valves close at the beginning of the diastolic notch (4). The period of rising tension lasts from the beginning of systole (1) to the opening of the semilunar valves (2).

Velocity of Blood Flow.—Insert the Pitot tubes E and F into a tube A through which water is flowing from a constant head of pressure B (Fig. 170). Note that the water rises to different levels

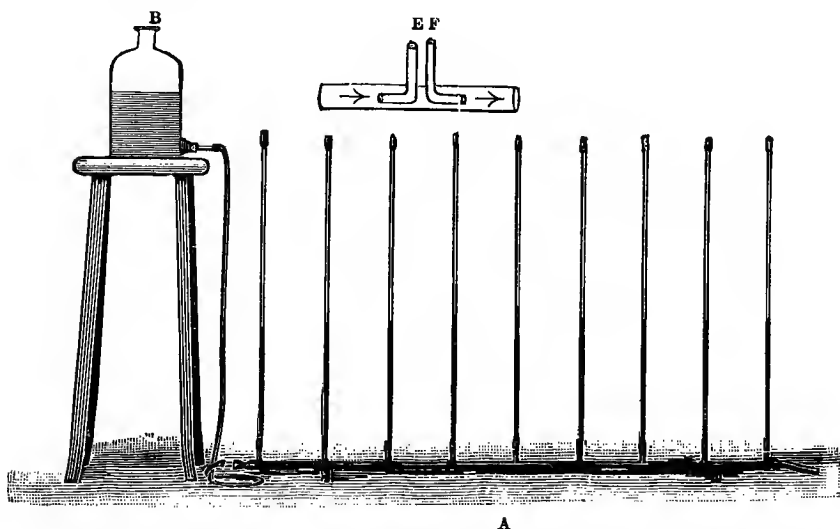

FIG. 170.—Schema to show the velocity and resistance heads. B, Pressure bottle. A, Tube with picnimeters. E F, Pitot tubes.

in the tubes. E represents the resistance head plus the velocity head. F records the resistance head minus the velocity head. Measure the outflow per minute from the tube A, and notice the difference between the heights of the menisci in E and F. Lessen the velocity by partly screwing up the clip on the end A. Measure the outflow per minute, and note that the menisci are nearer together. Close the end of A. The flow ceases, and the menisci in the two tubes reach the same level as that of the head of pressure B. Cybulski makes use of this principle in the construction of the photohaematochrometer, an instrument by which alterations in velocity can be recorded. Fig. 171.

The velocity can also be measured in the artificial schema by injecting 1 c.c. of methylene blue sat. sol. into artery, and noting by means of a stop-watch (or electric signal and drum) the moment of injection, and the moment when the blue fluid reaches the capillary tube.

The Circulation Time.—In the artificial schema measure the circulation time by injecting methylene blue into the vein V, and noting how long the blue takes to reach the venous end of the capillary tube.

The Work of the Heart.—To estimate the work of the heart in the artificial schema the mean pressure H, and velocity in the aorta V, and the volume of the systolic output Q, must be obtained.

$$W = QH \times \frac{MV_2}{2g}$$

M = the mass of the output in grammes = Q multiplied by the specific gravity of the blood.

Close the clip on the arteriole tube and start the pump. Note the mean pressure H indicated by the manometer M.

To obtain V inject into the artery, at 1 metre from the capillary tube, 1 c.c. of sat. sol. methylene blue. A side tube is provided for the purpose of making this injection. Note with a stop-watch, or by an electric signal and drum, the time between the injection and the appearance of the blue at the beginning of the capillary tube.

Having obtained V, the output can be reckoned if the sectional area (a) of the aorta be obtained and the time (t) of a cardiac cycle. Measure the diameter of the artery. Half this and obtain the radius.

$$a = \pi r^2, *$$

Count the number of pulses per minute, and by dividing the number found by 60 obtain t. Then $Q = avt$.

Now calculate the work of the pump from the data obtained. The work spent in maintaining velocity is almost negligible in comparison with that spent in overcoming resistance.

In man the output may be taken as 60 grms., the average aortic

* $\pi = \frac{22}{7}$

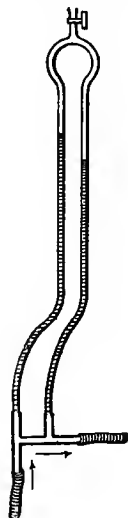

FIG. 171.—Cybulski's photo-haematometer. A cannula shaped as shown is introduced into the blood-vessel. The oscillations of the mercury-menisci are photographed.

pressure as 110 mm. Hg, the velocity of flow in the aorta as 320 mm. per sec. Mercury 13.5 times heavier than blood

$$\therefore W = 60 \times 110 \times 13.5 + \frac{60 \times 320}{2 \times 981}$$

The right heart is considered as doing one-third of the work of the left heart.

The total work of the human heart is estimated to be about 12,000 kilogramme-metres per day, or 500 kg.m. per hour. This equals about 28 kilo-calories (425 kg.m. = 1 kilo-calorie).

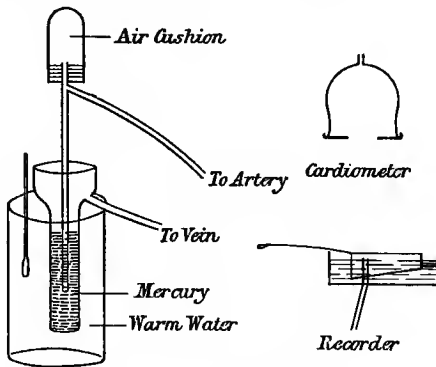

FIG. 172.—The Cardiometer.

In the dog the output can be obtained by estimating the amount of oxygen taken up by the blood from the inspired air in one minute. This can be obtained by Fredericq's or Zuntz's method (see p. 184). At the same time samples of arterial and venous blood are obtained, and the oxygen difference between the two samples estimated by the blood pump or Haldane's ferricyanide method (see p. 190). The number of heart beats per minute is also counted. Suppose 100 c.c. of oxygen are taken up per minute, the arterial blood contains 5 c.c. per cent. more oxygen than the venous blood, and the heart beats 80 times per minute. Then, as every 100 c.c. of blood carries away 5 c.c. O_2 , 2000 c.c. of blood must have passed through the heart in the minute. Thus the output

$$= \frac{2000}{80} = 25 \text{ c.c.}$$

The output in mammals is reckoned to be about .0012 of the body weight per sec.

The Cardiometer.—Demonstration of the method of recording the volume of the output of the heart. The cardiometer is made of

the end of a large thistle funnel, which is first covered with thin rubber membrane, and then a large round hole is made in the membrane by burning it with a soldering iron. The thorax is opened in the pithed cat after establishing artificial respiration, the pericardium is incised and the heart inserted through the hole in the rubber membrane into the funnel and this connected with a piston recorder. The rubber membrane fits snugly to the base of the ventricles and renders the cardiometer air-tight.

The carotid artery is connected as in the figure and the blood returns to the jugular vein, the circulation being confined by ligatures to the heart and lungs. The blood pressure is regulated by sinking the tube more or less deeply in the mercury.

CHAPTER XLII. (*Advanced Demonstrations*).

EFFECT OF HAEMORRHAGE AND SALINE TRANSFUSION.

In the anaesthetised and weighed animal a carotid cannula is introduced and another in the jugular vein. A third cannula is placed in the femoral artery. Observe the effect on the blood pressure tracing (1) of bleeding from the femoral artery, (2) running in physiological salt solution into the jugular vein.

Note the volume of blood withdrawn and saline introduced. To produce a fall of pressure 25 c.c. per kg. of body weight should be removed. After running in the saline, bleed the animal to death,

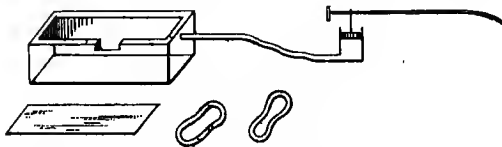

FIG. 173.—Diagram of an oncometer and piston recorder. The rubber bands fasten the glass lid in position.

and note the effect on the blood pressure tracing and the quality of the blood compared with that collected before transfusion. Look for fluid in the abdomen and observe the organs after death.

PLETHYSMOGRAPHS.

Plethysmographs and Oncographs.—In the pithed cat, tracheal, jugular, and carotid cannulae are introduced. The abdominal cavity

is opened and the greater splanchnic nerve exposed by blunt dissection where it lies just outside the supra-renal capsule. A ligature is tied round the nerve and the peripheral end stimulated.

Note that blood pressure rises. A cannula bent at right angles is placed in the bladder, and the left kidney in the oncometer. The kidney is laid on one of the pieces of the oncometer, its vessels being placed in the groove. The india-rubber bag filled with water at 38° C. is placed round it, and the other half of the oncometer put in position and the rubber bands applied. The tube of the rubber bag is connected with a water manometer, the water

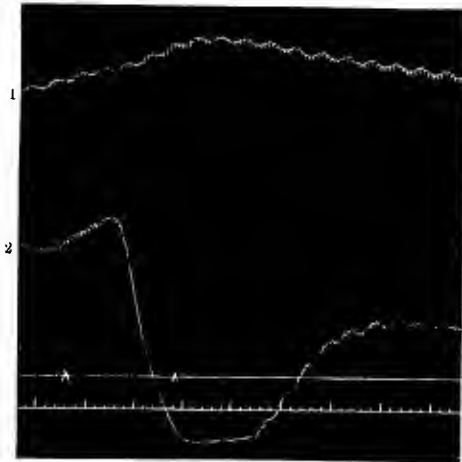

FIG. 174.—Arterial pressure (1) and oncometer tracing (2) of kidney volume. Between the points starred the 10th dorsal root was excited. The time is marked in seconds. (Bradford.)

being coloured with methylene blue. The manometer should show pulsations. Cover the abdomen with warm compresses of wool wrung out from hot 0.75 per cent. saline solution. Measure the outflow of urine for five minutes, and note the effect of stimulating the splanchnic nerve.

Note the effect of injecting 30 c.c. physiological salt solution into the jugular vein.

So long as the venous pressure is constant any increase in renal volume will denote increased blood-pressure in and increased blood-flow through the kidney. The secretion of urine varies as the volume of blood passing through the kidney per minute. (By dividing the renal nerves and exciting the spinal cord or vaso-motor centre the greatest rate of blood-flow through the kidney can be produced.) Ligature of the

renal vein stops the secretion of urine. After a temporary obstruction albuminous urine is secreted. Half a grain of citrate of caffeine injected intravenously will produce a fall of arterial pressure and a preliminary contraction of the kidney, followed by expansion and increased flow of urine. Observe the effect of extract of pituitary gland. This is the most active diuretic known (Schäfer).

Plethysmography of the Arm.—The arm is placed in the rubber gauntlet of the plethysmograph. The plethysmograph is connected with a recording tambour, a \perp -piece being interposed. Record the volume curve on a moderately fast drum. The tracing shows pulse waves and respiratory oscillations.

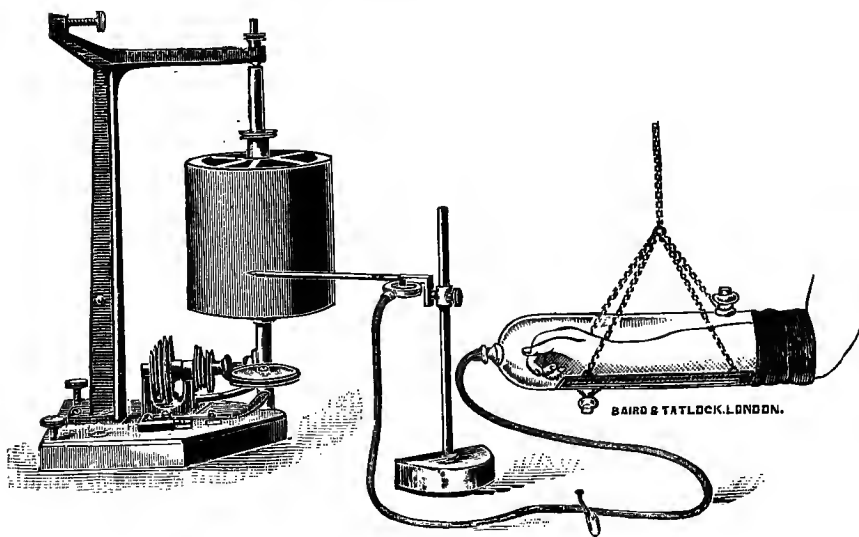

FIG. 175.—Limb plethysmograph.

Fasten the armlet of the sphygmometer round the upper arm and record the curve of venous congestion which results from raising the pressure in the armlet. Repeat this; after exertion the curve rises much more steeply. This is a good comparative method of studying the velocity of blood flow into man.

CHAPTER XLIII.

RESPIRATION.

Examination of the Chest of Man.—Much can be learned by simple methods of examination, and it is of the greatest importance that the medical student should rely more upon his sight, hearing and touch, than upon the graphic records obtained with different forms of apparatus.

Inspection.—The chest of a man stripped to the waist is examined and the following points are noted: (i) The shape, whether the thorax is strongly built and symmetrical, (ii) its mobility, whether the two sides move equally. The condition of the abdominal wall should then be examined, and attention paid to the development of its muscles and the movements during respiration.

The measurement round the chest of an adult man is about 35 inches and can be taken with a tape. The increase in circumference produced by inspiration is about 2 to 3 inches. It is impossible, however, to determine by such measurements whether a man has a good "wind" or not. A well-developed chest generally means that a man has lived an active life and has a good heart and lungs, but great variations are found in the shape of the chest of healthy men. The true test of a man's heart and lungs is whether he can respond to the demands of muscular exercise without undue breathlessness and distress. Even this test must be applied with intelligence, for the man may be under-fed, and may have led a very sedentary life.

A graphic record of the shape of the chest in different planes can be obtained with the *cyrtometer*. This simple instrument consists of two pieces of narrow lead piping hinged by a piece of rubber tubing. The hinge is placed over the vertebral column and the lead tubing is moulded round the sides of the chest in a horizontal plane; the *cyrtometer* is then opened, removed from the chest, placed in position on a sheet of paper, and its outline traced with a pencil.

The movements of the chest and abdomen should be observed and their relationship to inspiration and expiration determined. Some subjects show marked abdominal or diaphragmatic breathing, others breathe more by the thorax. In women the movement of the upper part of the chest is greater than in men; the causes of this difference are to be ascribed to the constriction of the abdomen and lower portion of the thorax by corsets and to the greater mobility of the thorax, due to the fact that in civilised countries the women do less

muscular work than the men. If hard work is frequently performed with the arms the upper portion of the thorax becomes more rigid, and this is an advantage, for it gives a better purchase for the contracting muscles.

There is no sound basis for the dogmatic teaching about thoracic and abdominal breathing of some so-called specialists in physical training. Healthy children do not need lessons in breathing, but opportunities for muscular exercise, for games in the open air. No reasonable athlete would attempt to improve his "wind" except by training it by progressively graduated runs. A good "wind" is something more complex than a big or mobile chest; it involves the heart which forces the blood through the lungs. Artificial breathing exercises are unsound; healthy games and sports train the whole body, the component parts of which are mutually dependent.

At rest breathing is performed by healthy subjects with the mouth closed, but during severe work it is opened instinctively and with advantage, for there is then less resistance to the passage of the air in and out of the chest, and the loss of heat is facilitated.

The rate of respiration in healthy adult men at rest varies from about 10 to 23 per minute: men who breathe slowly take deep breaths; those who breathe quickly take shallow breaths.

Palpation.—By placing the flat of each hand upon corresponding portions of the chest it is possible to compare the movements of the two sides of the thorax. If the subject be told to speak, to say "ninety-nine," for example, the vibration of the voice, *vocal fremitus*, is propagated through the bronchi to the wall of the chest, and thus to the hands of the examiner.

Percussion.—If a tap with the finger be given to the top of a table, the note will be dull over the part directly supported by the leg, but more resonant in the middle of the table. It is also easy for most men to detect a difference in the sense of resistance when the tap is given; it is greater with the dull note. In a similar manner the level of water in a tub can be determined. Such a method of investigation of underlying structures is known as percussion.

Firmly place the index finger of the left hand on the chest and tap it with the middle finger of the other hand. Determine the differences in note and resistance over the various parts of the thorax. On the right side the resonance extends from the apex of the lung in the supra-clavicular fossa to the beginning of the dulness produced by the liver under the 6th rib. On the left side it extends to the cardiac dulness which begins at the 4th rib.

Make the subject take a deep breath, and then by percussion

demonstrate that the limit of resonance is increased owing to the expansion of the lungs.

Auscultation.—The respiratory and cardiac sounds can be heard by placing the ear against the chest, or by means of a wooden or binaural stethoscope. Over the trachea, or at the level of the 7th cervical spine, the harsh blowing sounds, due to inspiration and expiration, are heard; these “bronchial sounds” are produced by the vibration of the air at the orifices of the vocal cords and divisions of the trachea and bronchi.

Another sound, the “vesicular murmur,” is heard on listening to parts of the chest wall where the lung is in contact. It is a soft breezy sound which increases during inspiration and dies away during the first third of expiration. There are several views about the causation of this sound; it may be due to conduction of the bronchial sounds.

CHAPTER XLIV.

INTRA-THORACIC PRESSURE.

Intra-thoracic Pressure.—The thoracic cavity, when opened, is far larger than its contents, for the lungs, owing to their elasticity, collapse as soon as the intra-pulmonary and pleural pressures become equal. The intra-pleural pressure is less than the atmospheric pressure by that amount of the atmospheric pressure which is required to overcome the elasticity of the lungs and distend these organs to the size of the thoracic cavity. The intra-thoracic pressure or elastic traction exerted by the lungs on the thoracic wall varies as follows:—

Normal inspiration	about	–	10 mm. Hg.
„ expiration	„		7 „
Deep inspiration	„	–	40 „
„ expiration	„		0 „
„ inspiration with air-way closed	„	–	100 „
„ expiration „ „ „	„	+	100 „

The intra-tracheal pressure varies from – 1 mm. Hg. in quiet inspiration to + 1 mm. Hg. in expiration. During forced breathing with the air-way closed the intra-tracheal pressure is greater than the intra-thoracic pressure by the amount of the elastic traction exerted by the lungs. All the structures, *e.g.* heart and blood-vessels, are affected by the respiratory variations of pressure.

DEMONSTRATION. The trachea of a dead rabbit is exposed, and a ligature tied round it. The skin is divided over the thorax on one side, and the ribs exposed. The intercostal muscles are carefully separated between two ribs. Note that the lung is in contact with the thoracic wall. The ligature round the trachea is now divided; the air escapes, and the lung, owing to its elasticity, will collapse. On opening the pleural cavity the pressure within and without the lung becomes atmospheric. The elasticity of the distended lung then comes into play and causes its collapse.

DEMONSTRATION. In the rabbit anaesthetised with urethane or chloral the skin is divided over an intercostal space. The intercostal muscles are then separated with care, and a piece of rib removed, while the parietal pleura is left quite uninjured. The lung will not collapse so long as the pleural cavity is not opened. On the contrary it will be seen gliding to and fro with each movement of respiration. Note how easily the pleural surface of the lung glides over the parietal pleura. A glass cannula attached to a water manometer is pushed throughout the intercostal muscles until the end comes to lie in the thoracic cavity. Notice the negative pressure indicated in the manometer, which becomes greater in inspiration and less in expiration. Note the immediate collapse of the lung on opening the pleural cavity.

CHAPTER XLV.

VENTILATION OF THE LUNGS.

THE SPIROMETER AND THE STETHOGRAPH.

THE ventilation of the lungs is determined by a gas-meter through which the subject breathes by means of an anaesthetic mask, provided with inspiratory and expiratory valves. Meters with a very low resistance are more convenient than the special instrument known as the spirometer (Fig. 176), although the latter is very useful for some experiments.

The subject of the experiment should breathe through the mask and meter for a minute or two before a record is taken, in order that he may become accustomed to the novel conditions. Then the volume of each breath and the number in periods of consecutive minutes should be determined. A table should be made to show the results obtained with each member of the class, for the differences in the rate and depth of breathing in healthy men are considerable; some men breathe slowly

and deeply, others take rapid and shallow breaths. The volume of air breathed per minute varies from 9 to 5 litres, the number of breaths from 23 to 10, and the averages for the volume of each breath from 900 to 250 c.c. It is important to remember as a general rule that what is lost in frequency is compensated in depth, so that the volume breathed per minute by a man with a frequency of respiration of 10 may be the same as that of a man whose ordinary rate of breathing is 22 per minute.

The **tidal air** is the volume of air breathed at each respiration, and it varies from 900 to 250 c.c. in different individuals. After breathing out the tidal air the subject should expire as deeply as possible; an additional 1500 to 2000 c.c. will be recorded. This is called the **supplemental air**. Now let the subject take as deep an inspiration as possible; it will be about 1500 to 2000 c.c. above the tidal air. This quantity is known as the **complemental air**.

The so-called **vital capacity** is the greatest volume of air that can be expired after the deepest possible inspiration; it is composed of tidal air 500 c.c. + complemental air 1500 c.c. + supplemental air 1500 c.c. It is about 3500 c.c., but too much

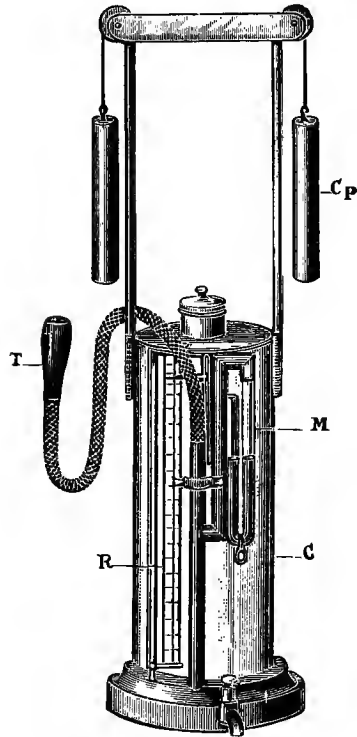

FIG. 176.—Spirometer. T, mouthpiece; M, manometer; Cp, counterpoise; R, scale.

importance should not be attached to it, for it depends largely upon practice and control of the inspiratory and expiratory muscles. A broken-winded bandsman, who is accustomed to control the blast of air which he delivers to his instrument, may have a so-called vital capacity greater than that of an athlete.

The Effect of Muscular Exercise upon the Respiration is very great; within a few minutes, varying according to the severity of the work and the condition of the subject, the volume of air breathed may be doubled, the number of breaths showing a smaller increase. The breathing is deeper, and the mouth is opened to diminish the resistance to the passage of the air in and out of the chest. Discomfort

or distress is caused by any resistance, and for this reason it is impossible to determine the true volume unless the resistance of the recording apparatus is low. Connect up two gas meters with a T-piece

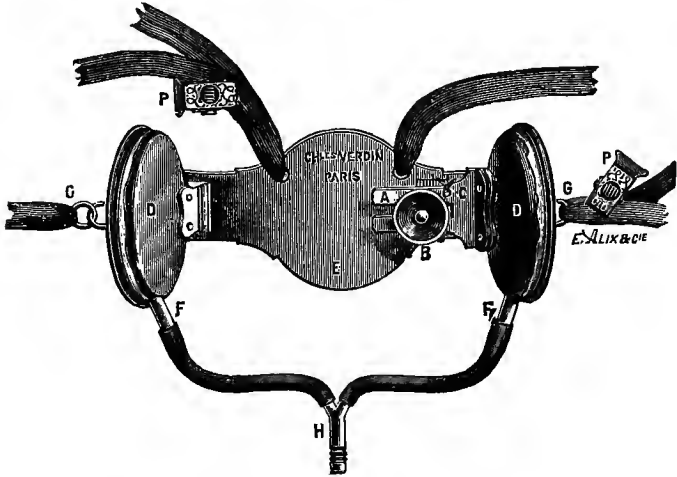

FIG. 177.—A stethograph employed to record the respiration and cardiac impulse of the rabbit or cat. The tamboours press on either side of the thorax. The T tube leads to a recording tambour.



FIG. 178.—Stethograph. A, Metal drum; B, hooks for tapes which pass round neck; C, rubber discs; D, hooks for attaching tapes which are tied round thorax; E, tube leading to the recording tambour.

and determine the volume and rate of respiration before and after running down and up a flight of stairs.

The Graphic Record of the Respiratory Movements.—For this purpose an instrument known as the *stethograph* is used. There are various forms, two of which are shown in Figs. 177 and 178. A receiving tambour constructed like a drum is fastened to the chest, and is connected with a recording tambour, the lever of which writes on a smoked drum. The subject of the experiment should not be allowed to see the movements of the lever, for the respiration is easily affected by nervous impressions. Take a graphic record of the respirations and mark the time relations of inspiration and expiration by means of a chronograph giving seconds.

CHAPTER XLVI.

CHEMISTRY OF RESPIRATION.

The Composition of Inspired Air, Expired Air and Alveolar Air.—For the analysis of these different samples of air the best apparatus is that of Haldane. The gas is measured in the graduated gas-burette A, provided with a three-way tap. Surrounding the gas-burette is a water-jacket. The whole is supported by a clamp and retort stand. The gas-burette is connected by pressure tubing to the levelling tube B, which is held by a spring clamp attached to the retort stand. A and B contain mercury, and by raising or lowering B gas can be expelled from or drawn into A. One of the connections of the three-way tap is used for taking in the sample, the other connects the burette with an absorption apparatus arranged as in the figure.

The bulb E, filled with 20 per cent. caustic potash, absorbs carbon dioxide. The bulb F, filled with alkaline pyrogallic acid solution,¹ absorbs oxygen. The water in G and H protects the pyro solution from the air. F can be emptied and refilled through K when it is necessary. The tap on the absorption pipette places either E or F in connection with the gas-burette.

The pressure in the burette is adjusted by using the potash pipette as a pressure gauge and bringing the potash before every reading of the burette to the mark M. In order to make the reading of the burette independent of changes in temperature and barometric pressure during analysis a control tube N is employed. N is connected with the potash solution by means of a T-tube. The tap at P makes it

¹ Dissolve 100 grms. of stick caustic potash in 50 c.c. of water. Add 10 grms. of pyrogallic acid to this solution.

possible to render the pressure in N equal to that of the atmosphere. At the beginning of the experiment the potash is adjusted to the mark R by altering S, P being open. P is then closed, and not opened again

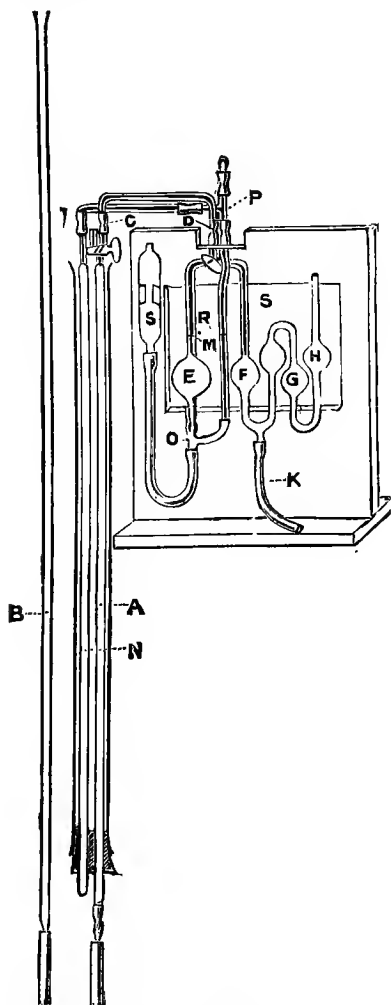

FIG. 179.—Haldane's gas analysis apparatus.

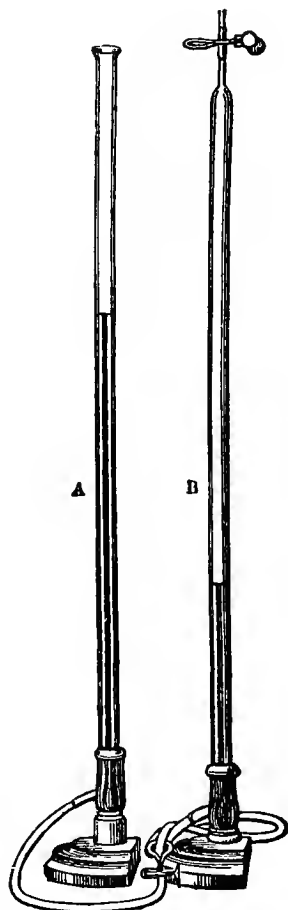

FIG. 180.—Hempel's burette for collecting a sample of expired air.

till the analyses are complete. The barometer and the temperature of the water-jacket are read. Each time a reading of the burette is made the potash is brought to the mark R by altering S, and to the mark M by means of the levelling tube B. As the control tube and the gas-

burette are kept moist, variations in the tension of aqueous vapour in the burette are also corrected by the control tube.

A sample of expired air is obtained by breathing through the tube into the burette B (Fig. 180). A and B are filled with acidulated water, and B is controlled by a clip.

The portion of B which lies beyond the clip is squeezed empty of air before it is inserted over the entrance tube of the Haldane gas-burette. The sample is then taken over by lowering the levelling tube and opening the clip.

Atmospheric Air, measured dry at standard temperature and pressure, 0° and 760 mm., has the following composition:—

Oxygen,	20.94 volumes per cent.
Carbon dioxide,	0.03 " "
Nitrogen,	78.09 " "
Argon,	0.94 " "

There are also traces of helium, krypton, neon, xenon, and hydrogen. The nitrogen and argon appear to be inert as far as the higher animals are concerned, and in ordinary analyses are given together as nitrogen.

The Expired Air varies in composition according to the rate and depth of respiration; this is shown by the following analyses made by Speck.

Type of breathing.	Volume of air expired per minute. c.c.	Percentage of oxygen.	Percentage of carbon dioxide.
Normal,	7,527	16.29	4.21
Very shallow,	5,833	15.50	4.63
Very deep,	17,647	18.29	3.17

Stated in whole numbers the composition may be given as follows:—

	Volumes per cent.		
	Oxygen.	Carbon dioxide.	Nitrogen.
Inspired air,	21	(0.03)	79
Expired air,	16	4	80

There are other differences between inspired and expired air. Under ordinary conditions expired air is warmed nearly to the temperature of the body and is saturated with water vapour; it has about 6 per cent. of moisture, whereas ordinary atmospheric air has about 1 per cent.

The expired air is a mixture of air from the so-called "dead space" of the respiratory tract and of air from the alveoli of the lungs, where the exchange of gases between the blood and the air takes place. The "dead space" extends from the nose to the alveoli and has a capacity of about 150 c.c. in an adult man. In an ordinary expiration the first portion of air to leave the nose or mouth is from this "dead space," then mixed air, and finally air from the alveoli.

The Alveolar Air.—The composition of the alveolar air is determined, according to the method introduced by Haldane and Priestley, by an analysis of the last portion of the air expired in an ordinary expiration. The experiment may be performed in the following way. An anaesthetic mask is connected by a T-piece to a piece of tubing 80 cm. long and 1·8 cm. internal diameter; to the free end of the T-

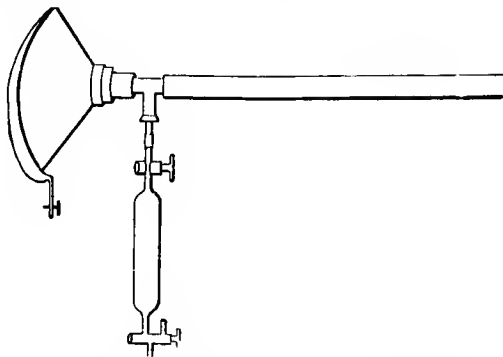

FIG. 181.—Apparatus for collection of a sample of Alveolar Air.

piece is connected (Fig. 181) a gas-sampler with a capacity of 50 cubic centimetres. The subject of the experiment fits the mask to his face and makes an ordinary expiration; as soon as the expiration ceases, the tap of the gas-sampler, the air of which has previously been removed by a vacuum-pump or gas-pump, is opened and a sample of the last portion of the expired air is collected before the mask is removed from the face. The analysis of the air is performed in the manner already described. The percentage composition is about 5·5 carbon dioxide, 14·5 oxygen and 80 nitrogen.

It is an advantage to determine the volume of each expiration by a spirometer attached to the end of the tubing, and it is important that the subject of the experiment should by a little practice with the apparatus learn to breathe naturally, otherwise a fair sample will not be obtained.

The partial pressure, or, as it is often called, the tension of the component gases is:—

Dry atmospheric air:

Oxygen approximately $\frac{21}{100} \times 760 = 159\cdot6$ mm. of mercury or 21 per cent. of an atmosphere.

Nitrogen approximately $\frac{79}{100} \times 760 = 600\cdot4$ mm. of mercury or 79 per cent. of an atmosphere.

Carbon dioxide approximately $\frac{0.03}{100} \times 760 = 0.228$ mm. of mercury
or 0.03 per cent. of an atmosphere.

The tensions of the gases of the alveolar air are calculated in a similar way, but the tension of aqueous vapour must be deducted from the pressure of the atmosphere.

CHAPTER XLVII.

DETERMINATION OF THE RESPIRATORY EXCHANGE IN MAN.

AN estimation of the intake of oxygen and output of carbon dioxide can be made by analyses of continuous samples of the air expired

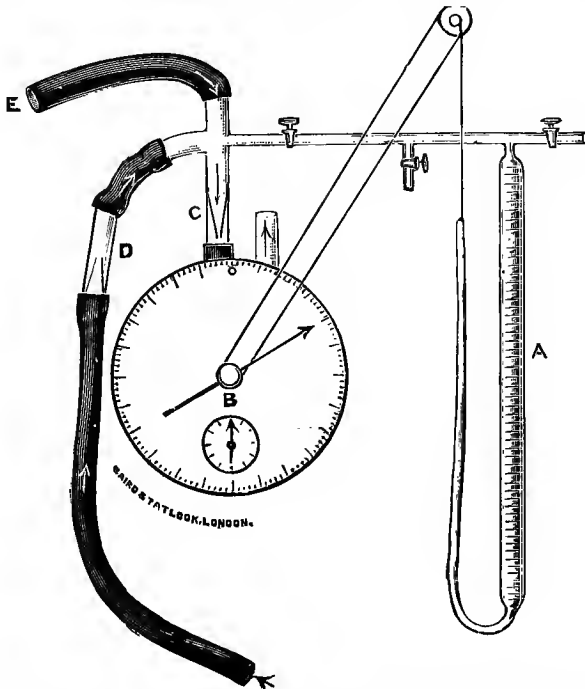

FIG. 182. Zuntz respiration apparatus. The subject expires through the meter. The inlet and outlet tubes are controlled by valves D and C, made of pieces of intestine which have been soaked in glycerine. A small sample of the expired air is steadily drawn off into the burette A by the escape of mercury from the tube which is lowered by the revolution of the meter B. The meter gives the total volume of air breathed. The measured sample in the burette is analysed by Haldane's gas apparatus.

through a meter. The method introduced by Zuntz for the purpose of collecting such a sample is illustrated in Fig. 182.

It will be sufficient if the student makes the determination in the following way. He should collect a sample of expired air and analyse it; then he should determine the average volume of air which he breathes in a minute. The methods involved have been described in previous chapters. From the data obtained a calculation can be made as follows :—

The man breathed 7 litres per minute, and the composition of the expired air was 16 per cent. oxygen and 4 per cent. carbon dioxide; he had, therefore, absorbed $21 - 16 = 5 \times \frac{7000}{100} = 350$ c.c. of oxygen and discharged $4 \times \frac{7000}{100} = 280$ c.c. of carbon dioxide. His respiratory quotient, the ratio of the volume of carbon dioxide discharged to the volume of oxygen absorbed is $\frac{\text{CO}_2}{\text{O}_2} = \frac{280}{350} = \frac{4}{5} = 0.8$.

There is a decrease of about $\frac{1}{10}$ in the volume of the expired air as compared with the inspired air, when both are measured at 0° and 760 mm.; the deficit is due to the absorption of a small quantity of oxygen which does not reappear in combination with carbon as carbon dioxide, but passes out of the body in other products of oxidation. The increased proportion of nitrogen in the expired air must be taken into account when the respiratory quotient is calculated from volumetric analysis; thus for every 100 c.c. of expired air the slightly larger volume of inspired air contained the following volume of oxygen :—

$$\text{O}_2 = \frac{20.94 \times \text{Nitrogen of expired air}}{79.07}$$

The respiratory quotient, therefore, in a case in which the percentages of nitrogen, oxygen and carbon dioxide are 80, 16 and 4, would be correctly calculated as follows :—

$$\text{Oxygen of inspired air} = \frac{20.94 \times 80}{79.07} = 21.18 \text{ c.c.}$$

$$\text{Oxygen absorbed} = 21.18 - 16 = 5.18 \text{ c.c.}$$

$$\text{Respiratory quotient} = \frac{\text{CO}_2}{\text{O}_2} = \frac{4}{5.18} = 0.77.$$

The respiratory quotient varies according to the nature of the food which undergoes oxidation in the body; thus, for carbohydrates it is 1, for protein 0.8, and for fat 0.7. The following formulae represent the oxidation of these different substances :—

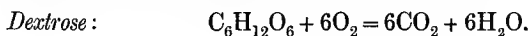

$$\frac{\text{CO}_2}{\text{O}_2} = \frac{6}{6} = 1.$$

Albumin (empirical formula) :

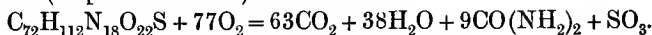

$$\frac{\text{CO}_2}{\text{O}_2} = \frac{63}{77} = 0.82.$$

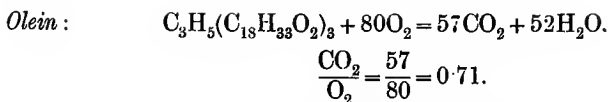

The effect of muscular exercise upon the respiratory exchange is most marked ; hard work may increase it three or four times.

For exact work upon the respiratory exchange of man a respiration chamber is required. Few laboratories possess such an expensive apparatus, but the principles can be studied in the simple form of respiration apparatus for mice.

CHAPTER XLVIII.

RESPIRATION APPARATUS.

The Haldane-Pembrey Respiration Apparatus for the Mouse.—The apparatus is constructed as in Fig. 183. Each double absorption tube is fitted with a wire loop, so that the glass need not be touched with the hand. The animal chamber—a light beaker—is provided with a thermometer and is also fitted with a wire loop. The moisture given off by the animal is absorbed by pumice saturated with sulphuric acid in the tubes AB. The carbon dioxide is removed by soda lime in the tube C, and the water given off by the soda lime is caught by the sulphuric acid tube D.

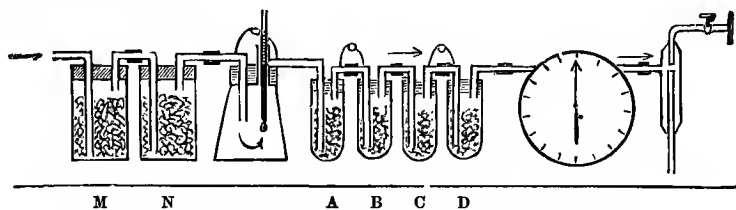

FIG. 183.—The Haldane-Pembrey respiration apparatus for the mouse.

The animal is weighed in the beaker (with the tubes closed) before and after the experiment. A dummy beaker is placed in the opposite scale pan. The tubes AB and CD are also weighed against a dummy pair of tubes. During the weighings the exit and entrance tubes are left unstoppered. By these means errors due to condensation of moisture and changes of barometric pressure or temperature are avoided, and the weighings can be carried out to less than a milligramme.

The air entering the chamber is freed from carbon dioxide and water

by soda lime in M and sulphuric acid pumice in N. The amounts of water and carbon dioxide given off in 15 minutes are determined by the increase in weight of AB and CD respectively. The amount of oxygen absorbed is found by subtracting the loss in weight of the animal weighed in the chamber from the total loss of carbon dioxide and water, for the animal absorbs during the experiment oxygen and loses water and carbon dioxide.

The ratio $\frac{\text{CO}_2 \text{ grms.}}{\text{O}_2 \text{ grms.}} \times \frac{32}{44} = \frac{\text{CO}_2 \text{ by volume}}{\text{O}_2 \text{ by volume}} = \text{respiratory quotient.}$

The effect of external temperature upon the respiratory exchange may be studied with this apparatus.

EXAMPLE. The beaker containing a full-grown mouse was placed in a water-bath at 9.5° C.; the mouse gave off from 250–315 decimgrms. of carbon dioxide per 10 minutes, and was *active*.

When the temperature of the bath was 30° C. the mouse gave off 103–116 decimgrms. carbon dioxide per 10 minutes, and was *quiet*. The rectal temperature of the animal scarcely varied during the experiment. Mammals born in a helpless condition, naked and blind, such as rats and rabbits, behave like cold-blooded animals, and are unable to compensate for low external temperature by increased metabolism; the output of carbon dioxide sinks as their body temperature falls.

CHAPTER XLIX.

THE CHEMISTRY OF RESPIRATION. THE GASES OF THE BLOOD.

IN a former chapter experiments were given to prove that the air which is taken into the lungs loses a portion of its oxygen and gains carbon dioxide; these changes correspond to differences in the gaseous contents of the blood; the venous blood loses carbon dioxide and gains oxygen in passing through the lungs, and thus becomes arterial. Analysis shows that blood contains about 60 volumes per cent. of gas, thus 100 volumes of arterial blood will yield 20 volumes of oxygen, 40 of carbon dioxide, and about 1 of nitrogen; 100 volumes of venous blood will yield 12 volumes of oxygen, 48 of carbon dioxide, and 1 of nitrogen.

Extraction and Analysis of the Gases of the Blood.—There are many forms of pump for the extraction of the gases of the blood; the general principle is the exposure of the blood to a barometric vacuum. It will be sufficient for the student to work with the simple form of

pump introduced by Leonard Hill. For other methods see Barcroft's papers on the subject in the *Journal of Physiology* or *Ergebnisse der Physiologie*, 7^{ter} Jahrgang, 1908.

The pump consists of a mercury reservoir A, which is connected with a second reservoir B by means of pressure tubing. The connection is surrounded by a mercury cup. The upper end of B is closed

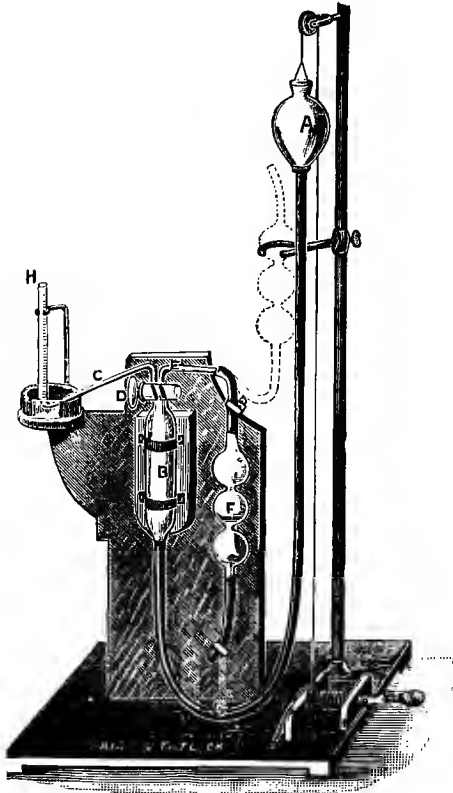

FIG. 184.—Hill's blood-gas pump.

by a three-way tap fitted with mercury cups. By means of this tap B can be put in connection with either the tube E leading to the blood-receiver F, or with the tube C leading to the eudiometer H. The blood-receiver F is constructed of three bulbs, so as to prevent the blood frothing over into B during the extraction of the gases. On the lower end of F is a three-way tap. To the upper end of F is fixed a piece of thick small-bored pressure tubing provided with a clip.

The mercury used to fill the pump must be cleaned and the pump

evacuated before use. In using the pump the manipulations are as follow: F is placed in the position indicated by the dotted line. A is raised and B is put in connection with F, and F is filled with mercury. The tap on the rubber tube at the upper end of F is then closed, and A lowered until F is exhausted, except for 2 or 3 c.c. of mercury which are purposely left within.

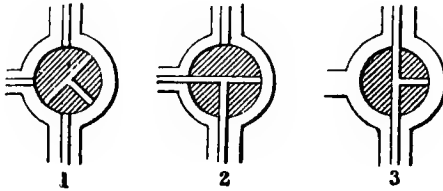

FIG. 185.—The three-way tap of the mercury pump.

The screw-clip on the lower end of F is next closed, and F is then detached from the pump and weighed. A sample of blood is collected in the following way: The arterial or venous cannula is connected by a rubber tube to F, and the tap turned so that the cannula and tube as far as the tap are filled with blood. A sufficient quantity of blood is now withdrawn by turning the tap into connection with F. It is now detached, and the blood is defibrinated by shaking it with the mercury left within F for the purpose. F is then again weighed, and the weight of the sample obtained. F is next affixed to the tube E, and E is exhausted. Finally the screw-clip between E and F is opened, and the gases are withdrawn and collected in the eudiometer. To facilitate the escape of the gases F is placed in warm water and shaken. If the blood froths too violently the frothing can be allayed by pouring some warm water on the tube E. The tap is so manipulated that the gases only, and not the water which condenses in B, are driven over into the eudiometer. The water is returned back into F. Several exhaustions are needed to extract the gases. The eudiometer tube is filled with mercury and surrounded with a water jacket to keep the temperature constant. The eudiometer is transferred to a vessel of mercury and the volume of gas read, the level of mercury inside and outside the eudiometer being the same. The temperature of the water in the jacket of the eudiometer is also

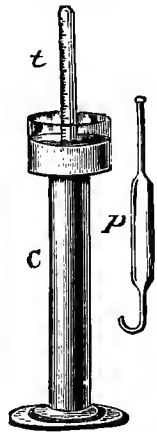

FIG. 186.—C, mercury vessel; t, eudiometer; p, pipette.

read and the barometric pressure. Potash solution 20 per cent. is then introduced into the eudiometer by means of a pipette provided with a bent end. The carbon dioxide is thus absorbed and the difference in volume read. Pyrogallic acid is then introduced and the oxygen absorbed. The remainder is nitrogen. The temperature of the water jacket is kept constant by adding cold water during the estimation. To correct the volume of gas to 0° and 760 mm. the following formula is employed:—

$$V = \frac{V'}{1+t \cdot 0.00367} \cdot \frac{H-f}{760}$$

where H = the observed pressure, f the tension of aqueous vapour at the observed temperature t . The value of $1+t \cdot 0.00367$ and of f are obtained from tables (cf. Sutton's *Volumetric Analysis*).

CHAPTER L.

THE OXYGEN CAPACITY OF BLOOD.

The Ferricyanide Method of Determining the Oxygen Capacity of Blood.—Haldane has introduced a simple method of determining the oxygen in combination with the haemoglobin of the blood. It depends upon the fact that the combined oxygen is liberated rapidly and completely on the addition of a solution of potassium ferricyanide to laked blood. The gas can be easily collected and measured with apparatus similar to that of Dupré for the determination of urea in urine.

The apparatus used by Haldane is shown in Fig. 187.

The process is conducted in the following way:—20 c.c. of oxalated or defibrinated blood, thoroughly saturated with air, are measured from a pipette into the bottle A. To this are added 30 c.c. of a weak solution of ammonia made from ordinary strong ammonia solution, sp. gr. 0.88, by diluting with distilled water to $\frac{1}{500}$ th. The ammonia prevents the evolution of carbon dioxide and the distilled water lyses the corpuscles. The mixture is thoroughly shaken to complete the laking. Into the tube B are placed 4 c.c. of a freshly saturated solution of potassium ferricyanide. The rubber cork is inserted into the bottle A and the water in the burette is brought to a level close to the top by opening the tap and raising the levelling tube. The tap is closed and the reading of the burette taken. The water gauge attached to the temperature and pressure control tube is adjusted by sliding the rubber tubing backwards or forwards on the glass tube D.

The bottle A is tilted so that the ferricyanide in B escapes and the mixture is shaken until the evolution of gas has ceased. If the pressure

gauge indicates an alteration in the temperature of the water this is adjusted by the addition of cold or warm water to the bath. After allowing the temperature to become constant and levelling the water in the burette and levelling tube, the amount of gas is read. The temperature of the water surrounding the burette and the height of

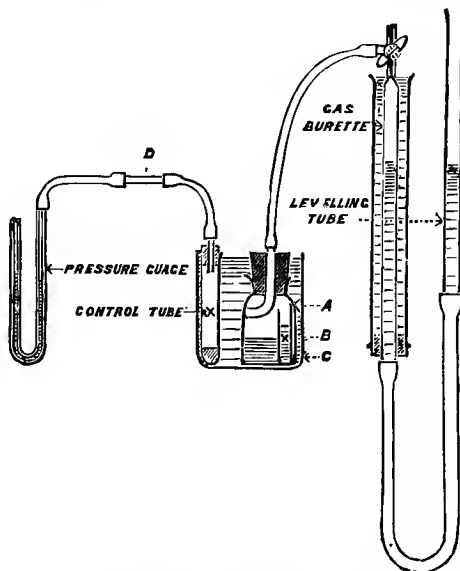
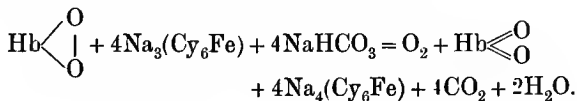

FIG. 187.— Ferricyanide method of estimating the oxygen capacity of blood.

the barometer are taken and the gas is reduced to its volume at 0° and 760 mm.

The chemistry of the process appears to be as follows:—The ferricyanide is reduced to ferrocyanide, for if ferricyanide be added to laked blood it will be found that the solution gives with ferric chloride the blue colour which indicates the presence of ferrocyanide. Oxygen is rendered available for the formation of methaemoglobin after the oxygen of the oxyhaemoglobin has been liberated.



In this case $\text{Hb} < \begin{array}{c} \text{O} \\ \diagdown \quad | \\ \diagup \quad | \\ \text{O} \end{array}$ represents oxyhaemoglobin, and $\text{Hb} < \begin{array}{c} \text{O} \\ \diagdown \quad | \\ \diagup \quad | \\ \text{O} \end{array}$

methaemoglobin, for it is held that the oxygen atoms are united together in oxyhaemoglobin but not in methaemoglobin.

CHAPTER LI. (*Demonstration*).

THE EFFECTS OF CHANGES IN ATMOSPHERIC PRESSURE.

Decreased Atmospheric Pressure.—**DEMONSTRATION.** A mouse and a frog are placed under the bell glass of the air pump (Fig. 189). A side tube is connected with a mercury manometer. The latter must be long enough to indicate the pressure of the atmosphere. On lowering the pressure $\frac{1}{2}$ - $\frac{1}{3}$ of the atmospheric pressure the mouse

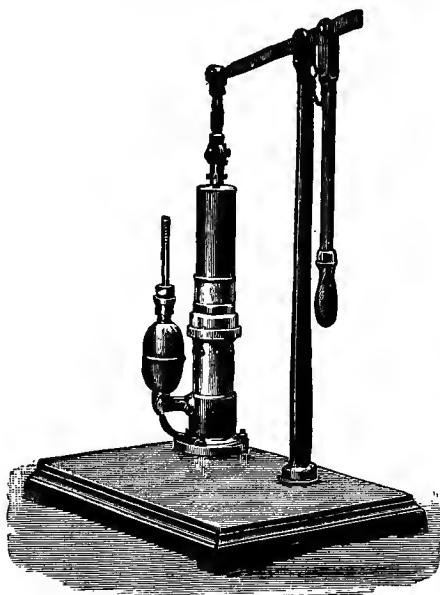

FIG. 188.—Geryk air-pump. The piston is covered with oil and opens a spring valve during its ascent.

becomes unconscious and asphyxiated, while the frog is unaffected. The effect of lessening the atmospheric pressure depends entirely on the partial pressure of oxygen. The normal pressure of oxygen is 20·94 per cent. of an atmosphere. At 10 per cent. of an atmosphere there arise restlessness and dyspnœa, and at about 4 per cent, death. A partial pressure of oxygen equal to 7 per cent. of an atmosphere corresponds to an altitude of 30 000 feet. Death from want of oxygen is common in foul wells, mines, etc.; where “choke-damp” collects, and has occurred in balloon ascents.

Increased Atmospheric Pressure.—DEMONSTRATION. A curarised frog, with the brain pithed, is placed in the high-pressure chamber, the web of one foot is spread out on a wire ring beneath one of the glass observation discs. The apparatus is screwed up and connected with an oxygen cylinder. The circulation in the web is observed with a microscope using an inch objective.¹ The pressure is increased

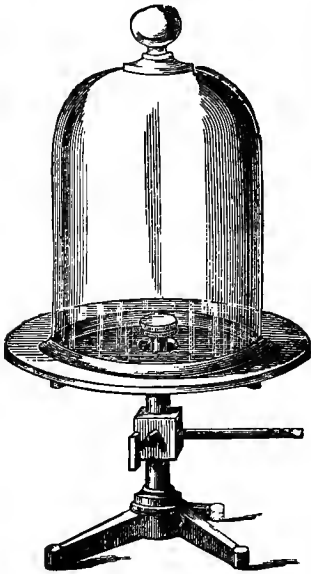

FIG. 189.—Receiver used with Geryk pump in demonstrating the influence of lowering the atmospheric pressure on animals. The apparatus may also be used as a drying chamber.

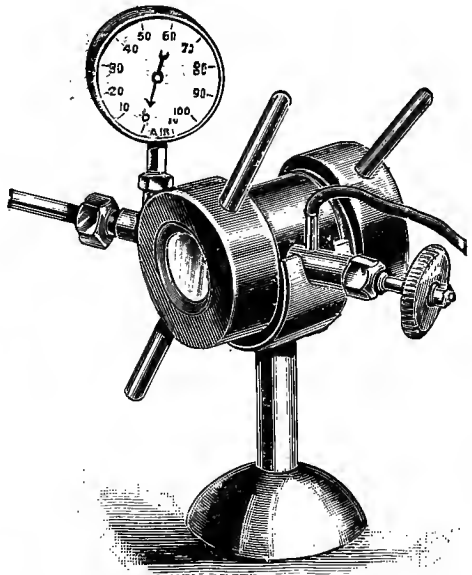

FIG. 190.—Hill's apparatus for studying effects of increased atmospheric pressure. Thick glass discs, provided with leather washers, close the ends of the chamber.

to 20-30 atmospheres. The circulation continues unaffected, for the pressure is equally transmitted throughout the fluids of the body. After ten minutes the chamber is decompressed. Emboli, formed of gas bubbles, may appear in the capillaries, and the circulation ceases.¹ Such gas emboli are the cause of the symptoms (paralysis, etc.) observed in caisson workers and divers. Every 10 metres in depth of water roughly equals one atmosphere. The workers are affected on or after decompression. Re-compression and slow decompression is the rational cure for the symptoms when they appear. Compressed oxygen is also *per se* a poison. It lowers metabolism, diminishing

¹ The image of the circulation can be projected upon a screen with the aid of an arc light.

the output of carbon dioxide and the body temperature. This can be observed in mice placed in a high-pressure chamber. A mouse is affected with dyspnoea in 10 atmospheres of oxygen, goes into convulsions and soon dies. In 50 atmospheres it is instantly killed.

CHAPTER LII.

THE INFLUENCE OF CARBON MONOXIDE.

CARBON MONOXIDE is a poisonous gas in virtue of its great affinity for haemoglobin; oxygen is displaced and carboxyhaemoglobin is formed. Unconsciousness, convulsions, and death are produced by the lack of oxygen which arises when a large portion of the haemoglobin is combined with carbon monoxide and thus deprived of its power of carrying oxygen.

Carbon monoxide is present as an impurity in coal-gas, and in water-gas, which is often used in the adulteration of coal-gas, the percentage is a very high one. It is due to this gas that death so often results from coal-gas poisoning. In the air of mines after an explosion there is present a large quantity of carbon monoxide, due to the incomplete combustion of coal dust; miners overtaken by such a disaster generally die from poisoning by this gas.

DEMONSTRATION. A white rat or mouse is selected for the experiment, for it is easier in such animals to see in the snout and feet the change of colour due to the formation of the carboxyhaemoglobin. The animal is placed under a glass bell jar and coal-gas is admitted; it becomes restless, unconscious, convulsed, and dies within a few seconds. This is one of the quickest methods of killing an animal, and has the advantage that it rapidly produces unconsciousness.

If the animal be removed to free air at the beginning of the stage of unconsciousness it may recover. The carboxyhaemoglobin is gradually dissociated and oxyhaemoglobin is formed in its place. In rabbits this occurs very rapidly; the animal quickly recovers, passing through a stage of incoordination.

Haldane has shown that the best indicator of the presence of poisonous doses of carbon monoxide is a small warm-blooded animal, such as a mouse or bird, which is affected, owing to its rapid respiratory exchange, much sooner than a man. This method has been employed with success by rescue parties entering a coal mine after an explosion.

The colour of the snout and feet of the white mouse or rat killed by carbon monoxide is pink or cherry red. The blood in the viscera has a

similar colour and the contrast between the appearance of an animal killed by ordinary asphyxia produced by a blow on the head and one killed by lack of oxygen due to carbon monoxide is very striking.

Perform this simple and practical test for carbon monoxide. Kill two animals, one by a blow on the head, the other by coal-gas. Cut open their bodies and compare the colours of the viscera. Place a drop of blood from each animal in separate test tubes, dilute with distilled water and examine in good daylight. The blood containing carboxyhaemoglobin can be distinguished easily by its cherry red colour; it is more pink and less yellow than the ordinary diluted blood. This test can be confirmed by the examination of the two samples of blood with the spectroscope (p. 346).

The treatment of cases of carbon monoxide or coal-gas poisoning is to give oxygen to increase the dissociation of carboxyhaemoglobin and to keep the patient warm in order that his metabolism and the excitability of his nervous system may be raised.

CHAPTER LIII.

THE REGULATION OF RESPIRATION.

THE ventilation of the lungs is regulated by a nervous centre in the medulla oblongata. This can be proved by a series of experiments, in which different portions of the central nervous system are destroyed.

DEMONSTRATION. The medulla of an anaesthetised animal is destroyed in the region of the calamus scriptorius; respiration ceases immediately and the animal dies of asphyxia.

By experiments upon other animals it can be proved that destruction of no other part of the central nervous system will produce this sudden cessation of all respiratory movement. If the spinal cord be divided close to the medulla the chief respiratory muscles will be paralysed, but the movements of the nares will show that the centre is not destroyed.

The respiratory centre is influenced in two ways: (i) by the composition of the blood which supplies it, and (ii) by nervous impulses which affect its excitability. Experiments upon these points can be performed by the student upon himself; he can alter the composition of the air in his lungs and thus affect the gaseous composition of his blood.

Influence of breathing air containing carbon dioxide.—The subject of the experiment breathes air through a mask and valves and the

ventilation of the lungs is determined by a meter. Then, unknown to the subject, the air to be breathed is taken from a gas bag containing air with 3 or 4 per cent. of carbon dioxide. The breathing is increased. Carbon dioxide stimulates the respiratory centre. In order to check any effects of change in resistance or of suggestion the gas bag should, unknown to the subject, be filled with pure air and the experiment repeated. Air containing 8 or 9 per cent. of carbon dioxide will produce intolerable discomfort or distress.

Influence of breathing different percentages of oxygen.—After breathing air for some time, the subject breathes pure oxygen from a bag: the rate and volume breathed generally show no change, if precautions have been taken to avoid the effects of suggestion. If the oxygen be moistened with water most men cannot distinguish it from air taken from a similar bag.

Air containing about 15 per cent. of oxygen can be collected free from carbon dioxide by breathing slowly through a flask or tin of soda lime into a gas bag. Experiments with this gas will show no change in the rate or volume of the air breathed. A fall of 5 or 6 per cent. in the amount of oxygen in the air is not detected. When the oxygen is only 10 per cent. effects are produced; these will be studied in later experiments.

Influence of holding the breath.—Hold the breath to the “breaking point” and then collect a sample of alveolar air. The carbon dioxide will rise to 7 or 8 per cent.; the oxygen will fall to about 10 per cent.

Repeat the experiment after breathing oxygen for two or three minutes. The “breaking point” will not occur so soon, but the rise in the carbon dioxide will be the determining factor, for the oxygen in the alveolar air may be above 20 per cent. at the end of the experiment. The carbon dioxide may rise to 10 per cent.

Influence of forced breathing.—Take a series of rapid and deep breaths for about half a minute, recording the movements by the stethograph. Stop breathing when a sensation of giddiness is experienced. There will be no inclination to breathe for about a minute. The condition is one of *apnoea*, due to the washing out of carbon dioxide from the lungs and blood. The composition of the alveolar air will indicate the changes which occurred, as shown by the following example. The subject breathed rapidly and deeply, 17 times in 18 seconds. A sample of alveolar air from the last expiration yielded on analysis 2·50 vols. per cent. of carbon dioxide and 19·23 of oxygen. Apnoea followed. The sample of the first expiration, when a desire to breathe was felt, had the following composition: carbon dioxide 5·59 vols. per cent., oxygen 12·59 per cent.

The experiment should then be repeated with this difference; oxygen instead of air should be breathed. The period of apnoea will be much longer, for the subject of the experiment will have more oxygen in his lungs and more in his venous blood.

Forced breathing interferes with the circulation and often produces giddiness. An examination of the pulse will show that the systolic pressure is diminished by each inspiration. If oxygen is taken in during forced breathing there is less discomfort; the brain receives more oxygen even if its circulation of blood is disturbed.

Influence of Muscular Exercise.—The subject of the experiment should take vigorous muscular exercise sufficient to produce hyperpnoea, but not long enough for the production of “second wind.” A sample of alveolar air taken immediately after the exercise will show in many cases a considerable rise in the percentage of carbon dioxide and a small fall in that of oxygen. If the exercise be continued until “second wind” has been established, the alveolar air will show less carbon dioxide and more oxygen. This accommodation varies in different subjects, but the following example may be given.

PERCENTAGE COMPOSITION OF ALVEOLAR AIR.

Carbon dioxide. Vols.	Oxygen. Vols.	$\frac{CO_2}{O_2}$	
5.27	14.32	0.79	At rest.
7.36	14.03	1.06	After running $\frac{1}{2}$ mile.
5.91	14.62	0.93	After running $\frac{1}{2}$ mile more. “Second wind.” Sweating.

“Second wind” appears to be a complex adjustment of the respiration and circulation to the demands of muscular work.

CHAPTER LIV.

CHEYNE-STOKES RESPIRATION.

IN certain cases of heart-disease a well-marked alternation of apnoea and hyperpnoea was observed and described by Cheyne and Stokes. This phenomenon is characterised by a period of waxing and waning respiration followed by a period of apnoea (Fig. 191).

In some healthy men Haldane and Douglas have shown that this type of periodic breathing can be produced in the following way. The subject breathes through a small tin of soda lime provided with wire gauze to prevent the suction of small pieces of soda lime into the

mouth, and connected at the far end with a piece of tubing about 260 cm. long and of about 2 cm. bore. The subject thus rebreathes his own expired air after it has been deprived of carbon dioxide by the soda lime. The percentage of oxygen necessarily falls, the respiratory centre becomes excited and hyperpnoea begins. Some fresh air from outside the tube will be taken in with each deep breath and the percentage of oxygen will rise. The hyperpnoea, however, has washed



FIG. 191.—Cheyne-Stokes respiration. (Pembrey and Allen).

out a quantity of carbon dioxide from the blood and air in the lungs, and apnoea results owing to lack of sufficient carbon dioxide to excite the respiratory centre. Thus this alternation of breathing and apnoea may continue for several minutes or, it may be, hours. Some healthy men exhibit Cheyne-Stokes respiration readily when they perform this experiment; others do not.

Apnoea can be abolished by either (i) air containing 3 or 4 per cent. of carbon dioxide, or (ii) pure oxygen, or (iii) air containing a deficiency of oxygen, about 12 per cent. of oxygen.

CHAPTER LV.

THE INFLUENCE OF THE VAGUS UPON RESPIRATION.

THE lungs are supplied with motor and sensory fibres from the vagus nerve; the motor fibres pass to the involuntary muscle fibres of the bronchioles and control their contraction; the sensory fibres carry impulses from the lungs to the respiratory centre to co-ordinate the respiratory movements. The latter group of fibres can be stimulated by the degree of distension of the alveoli, and may be divided into expiratory and inspiratory fibres.

DEMONSTRATION. A rabbit is anaesthetised with chloral, urethane, or ether. The trachea and vagi nerves are exposed and a cannula is placed in the trachea. The respiratory movements can be recorded and rendered visible to a large class by fastening one end of a thread to a tuft of fur in the epigastric region and the other end to a lever. The rate and depth of respiration are observed, then the effect of blowing air into the lungs, and, after an interval, the effect of sucking air out of the lungs. Positive ventilation produces expiratory apnoea, negative ventilation a condition of continued contraction of the diaphragm.

One vagus is now divided; little or no change will be observed in the rate and depth of respiration, but when the other vagus is cut the breathing becomes very slow and deep. The experiments of positive and negative ventilation are repeated. The effects previously seen are absent. It is possible, however, by excessive ventilation of the lungs to reduce the pressure of carbon dioxide in the blood and produce apnoea.

The rabbit is now killed, and the tracheal cannula is connected with a water manometer. Excitation of the peripheral end of the vagus with a faradic current will cause a small rise of pressure in the manometer, due to the contraction of the bronchial muscles.

The rhythm of respiration is maintained by the changes in the composition of the blood, not by reflex action due to alterations in the distension of the lungs. The vagus, however, influences the respiratory centre, thereby co-ordinating the respiratory movements, and, in addition, it is probable that it influences at the same time the cardiac centre and harmonises the working of the heart and lungs.

After section of both vagi the animal dies in a day or two from septic broncho-pneumonia, due to the passage of food or saliva into the trachea and bronchi. The larynx is paralysed by section of the vagi

high up in the neck, and even if the nerves be cut below the laryngeal branches, the paralysis of the oesophagus leads to such an accumulation of food therein that particles pass over into the respiratory tract. Dogs with a double oesophageal fistula have lived for months after section of both vagi; the fistulae prevent the passage of food or saliva into the trachea and lungs.

CHAPTER LVI.

ANIMAL HEAT.

Difference between Warm-blooded and Cold-blooded Animals.—

Warm-blooded animals, such as mammals and birds, regulate their bodily heat so that their internal temperature remains constant notwithstanding changes in the temperature of their environment; there is little or no difference in the internal temperature of men whether they be living in the tropics or in the arctic regions. Cold-blooded animals cannot regulate their bodily heat; their internal temperature varies with and in the same direction as that of their surroundings. There is, however, no hard and fast distinction between the warm-blooded and the cold-blooded animals. Hibernating mammals, such as the hedgehog, dormouse, and bat, are warm-blooded during the time of activity, but become cold-blooded when they hibernate. Young mammals and birds in a natural condition of immaturity, when they are naked and blind, cannot maintain their temperature at a constant level; they need the warmth of the parent's body. A similar condition is seen in delicate or premature infants.

The Temperature of Man.—The average temperature of man is 98°·4 F. (36°·89 C.). It is taken by means of a clinical thermometer which is either inserted in the rectum, axilla, or mouth, or the subject micturates over the bulb of the thermometer. Take the temperature of your mouth at each hour of the day. Chart out the results on a temperature chart and observe the daily variation (Fig. 192). Take the temperature before and immediately after muscular exercise, such as a fifteen minutes' run. The temperature may rise to 100°–101° F. (37°·78–38°·33 C.) or even more on a hot day. A rise of temperature can be constantly observed if the thermometer be placed in the rectum or stream of urine; the buccal temperature may for the reasons given below show a *fall* in temperature during muscular work. It is important to remember that the daily range in the internal temperature of a healthy man may be from 97°·0 F. (36°·1 C.) to 99°·6 F. (37°·56 C.);

and that observations taken in the mouth, even when it is firmly closed, are liable to be low, owing to the danger of cooling of the tissues of the mouth, externally by cold air, internally by the inspired air.

Heat Regulation.—Take a large frog, and insert a small thermometer in the rectum or flex up the thigh, and insert the thermometer between it and the abdomen, and record its temperature. Place the frog in warm water at 30° C. After 10 minutes observe its temperature. It will have reached the same temperature as the water. Cool the frog again in cold water and take its temperature again. Then place it for 10 minutes in a thermostat heated to 35° C. In the dry

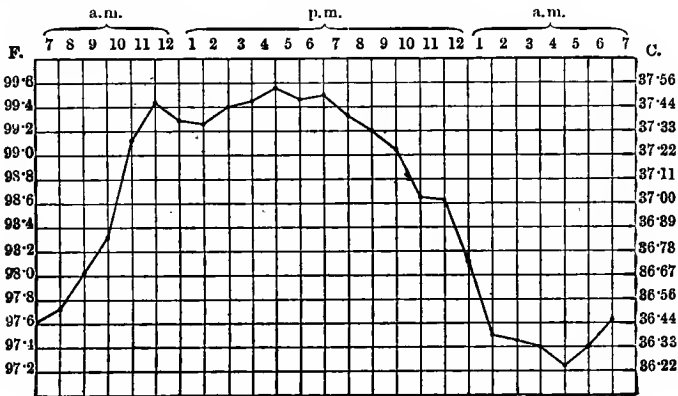

FIG. 192.—Daily variation of temperature of man. (M. S. P.)

warm air the frog's temperature will not rise to more than about 30°–33° C. This is owing to the evaporation of water from the frog's skin. Take the temperature of a mouse in the rectum and then place it in a dry thermostat at 30° C. for 10 minutes. The temperature of the animal will scarcely vary. Note the quickened respiration of the animal. This increases the evaporation of water from the lungs. Note the way it sprawls out its limbs so as to increase the loss of heat by radiation, convection, and conduction. A man cannot bear for more than a few minutes immersion in a bath of water at a temperature of 44° C., but he can stay for twenty minutes in a dry atmosphere heated to 121° C. The body temperature is then regulated by sweating.

Loss of Heat.—An approximate estimation of the amount of moisture lost by a man during exercise or exposure to heat can be made by weighing him naked before and after the exercise. Moisture is lost from the skin and lungs, chiefly from the former.

The temperature of the skin also influences the loss of heat by

radiation, convection and conduction. It may be readily taken by a mercurial thermometer with a flat bulb. A difference of 10° C. may be observed in the temperature of the skin of the hand in summer and winter; in warm weather the cutaneous blood-vessels are dilated, in cold weather they are contracted. The temperature, however, of those parts of the body which are constantly covered with clothing shows little change.

Clothes diminish the loss of heat from the body by enclosing layers of stationary air, so that the surface of the trunk and limbs is surrounded by a layer of air nearly as warm as the skin.

EXPERIMENT. Take the temperature of the skin of the hand and compare it with that of the chest or abdomen. Compare also the temperatures recorded in the air space between the coat and waistcoat, between the waistcoat and shirt, between the shirt and vest, and lastly between the vest and skin. In cold weather it will be found that the temperature of these strata of air shows a progressive rise, so that the air between the vest and the skin is almost as warm as the skin itself.

The heat lost from the skin depends upon the temperature and moisture of the air. The temperature recorded by the wet-bulb thermometer is the important factor; it can be taken by wrapping some moist cotton round the bulb of a thermometer and waving it in the air, but always keeping it upright, so that no mechanical displacement of the mercury may occur.

Sweat.—The discharge of sweat is under the control of the nervous system, and a simple experiment will prove the existence of sudorific nerves. A cat is killed by an overdose of ether or chloroform. The sciatic nerve is exposed and stimulated by a strong faradic current; after a short delay beads of sweat will be seen on the pads of the foot. The pad of the opposite leg will serve as a contrast.

Effect of Anaesthesia on the Temperature of the Body.—**DEMONSTRATION.** A small mammal is anaesthetised with chloral or urethane after its rectal temperature has been taken. If the animal be now laid on a table with its limbs spread out, and be exposed to the ordinary temperature of a room, its temperature will fall. This is chiefly due to the cessation of muscular movement and the paralysis of the central nervous system, which regulates the temperature of the body. The same effect follows curarisation; section of the spinal cord in the lower cervical region; and the administration of large doses of alcohol.

Anaesthetised patients must be protected from cold. Drunkards who fall asleep on the roadside on a winter's night are easily "frozen to death."

CHAPTER LVII.

INVESTIGATION OF THE MOTOR FUNCTIONS OF THE ALIMENTARY CANAL BY MEANS OF THE X-RAYS.

By A. F. HERTZ, M.A., M.D., F.R.C.P., Assistant Physician, late Demonstrator of Physiology, Guy's Hospital.

THE soft viscera are transparent and the salts of the heavy metals are opaque to the X-rays. When therefore any part of the alimentary canal contains food mixed with such a salt, it casts a shadow on the florescent screen, when X-rays pass through the body. Bismuth salts are those generally employed, as they are not absorbed and do not irritate the mucous membrane. The oxychloride is the most useful for this purpose, as it is unaffected by the hydrochloric acid of the gastric juice, and passes through the alimentary canal without influencing its motor functions in any way.

A small breakfast should be taken on the morning of the examination in order that the stomach may be as empty as possible when the bismuth meal is eaten. Half a pint of bread and milk mixed with two ounces of bismuth oxychloride forms the meal. A penny should be fixed over the umbilicus by means of strapping, so that the position of the stomach and intestine in relation to the umbilicus may be recognised. It is unnecessary to take photographs, but the outlines of the shadows seen on the screen should be marked out with blue chalk on a superimposed piece of glass, and subsequently copied on to paper.

Swallowing.—The examination is begun in the vertical position. A large mouthful of the bread and milk is swallowed, and its passage through the oesophagus into the stomach is watched. For this purpose the rays should pass in an oblique direction through the thorax from the front of the right side to the back of the left side in order that nothing should interfere with the view of the oesophagus, which traverses the clear area between the shadow of the heart in front and that of the spine behind. In the vertical position the food passes with great rapidity to the back of the pharynx, and thence equally quickly down the upper part of the oesophagus. A mouthful of ordinary size occupies at any given moment between one and two inches of the length of the oesophagus. If several mouthfuls are swallowed in rapid succession the whole of the oesophagus becomes visible as a dark shadow.

When the fluid reaches the cardia, its rapid progress is arrested owing to the sudden diminution in the lumen of the oesophagus. The

lower end of the column of food tapers to a point which represents the cardiac orifice of the stomach, the upper limit becoming horizontal. At a comparatively slow rate the upper horizontal limit of the shadow descends, the lower part remaining unaltered in shape and position until the last trace of the shadow has disappeared. This means that the fluid runs slowly through the narrow cardia into the stomach after having been shot rapidly down the greater part of the oesophagus.

The time which elapses between the initiation of the deglutition act and the disappearance of the last trace of fluid from the oesophagus should be measured with a stop-watch. It varies between four and nine

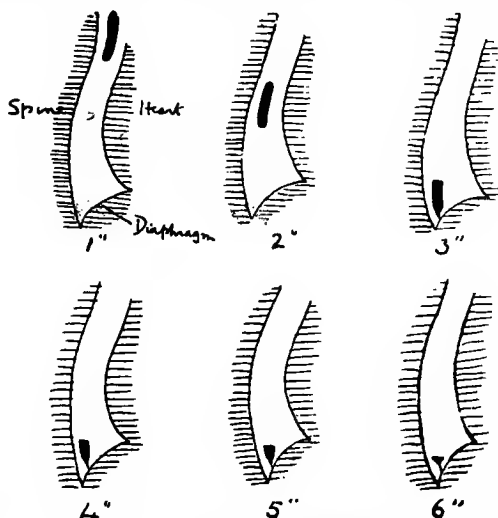

FIG. 193.—Diagrams of position of shadow in oesophagus at intervals of a second after swallowing.

seconds in different individuals. About one-half of the total period is required for the food to reach the lower end of the oesophagus, the other half being required for its passage through the cardia.

Fig. 193 represents diagrammatically the shadow as seen at intervals of a second.

In the horizontal position the fluid passes along the oesophagus slightly less rapidly than in the vertical position. A similar but more prolonged delay takes place while the food passes through the cardia, the prominent end of the column being in this case rounded. Sometimes a small quantity of the food follows more slowly, and appears as a thin streak instead of the comparatively broad band seen when the oesophagus is filled.

In the inverted position, with the head directed downwards, the

food can be seen steadily ascending the oesophagus at about one-third the rate it descends in the vertical position. Owing to its slower passage, the final delay at the cardia is less obvious. Sometimes a little fluid runs back from the stomach into the cardiac end of the oesophagus, whence it once again passes into the stomach.

The Stomach.—The X-ray tube is now lowered so that the rays may traverse the abdomen, and the individual faces directly forwards. Under the left half of the diaphragm a transparent area is visible, which

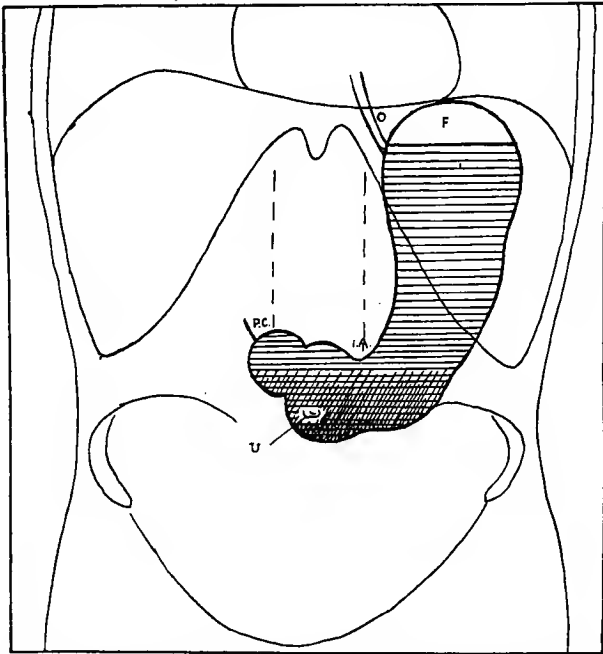

FIG. 194.—Diagram of shadow of stomach. F=fundus; Pc=pyloric canal; U=umbilicus.

represents the gas normally present in the fundus of the empty stomach. More of the bread and milk is now swallowed, and it can be seen entering the fundus to the right of this clear area; the shadow of the stomach becomes gradually more obvious as more of the food is taken. The tone of the stomach diminishes as more food enters, so that the intragastric pressure remains constant. Consequently the upper and lower limits of the shadow remain almost constant, whatever quantity of food is present. When the whole of the meal has been taken, the outline of the stomach should be marked on the screen, together with the position of the umbilicus. In nearly every case the greater

curvature reaches a short distance below the level of the umbilicus. The main part of the stomach is almost vertical, and is situated to the left of the middle line. The pyloric end, however, passes upwards and to the right across the middle line (Fig. 194). The upper limit of the gastric contents is situated about $1\frac{1}{2}$ inches below the diaphragm, and is bounded by a horizontal line, above which is the gas-containing fundus.

On voluntarily contracting the abdominal muscles the lower border of the stomach is raised several inches, and on relaxing them it generally drops an inch or two.

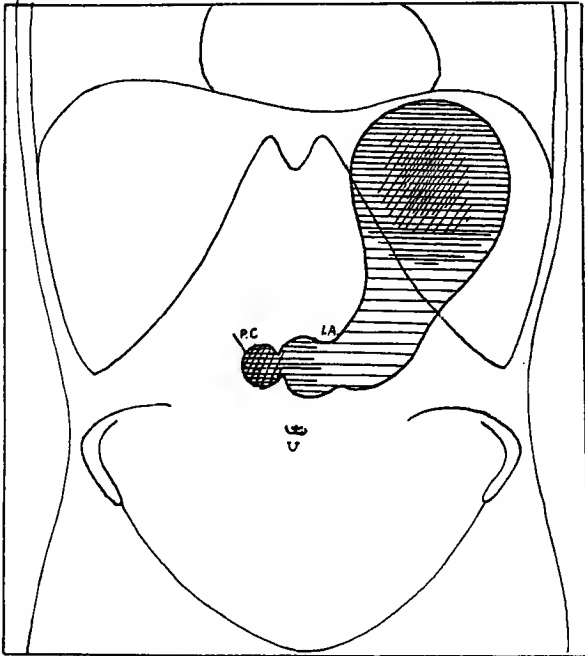

FIG. 195.—Diagram of shadow of stomach in the horizontal position.

The peristaltic waves can be seen passing from the centre of the greater curvature towards the pylorus. They can, however, be more conveniently studied in the horizontal position.

The examination should be continued in the horizontal position. The greater curvature is now seen to have risen above the umbilicus, and the clear area in the fundus is no longer visible (Fig. 195), the gas having moved to the most superficial part of the stomach, corresponding with which a resonant area can be marked out by percussion below and to the left of the area of cardiac dulness.

Peristalsis should now be studied in more detail. The waves start

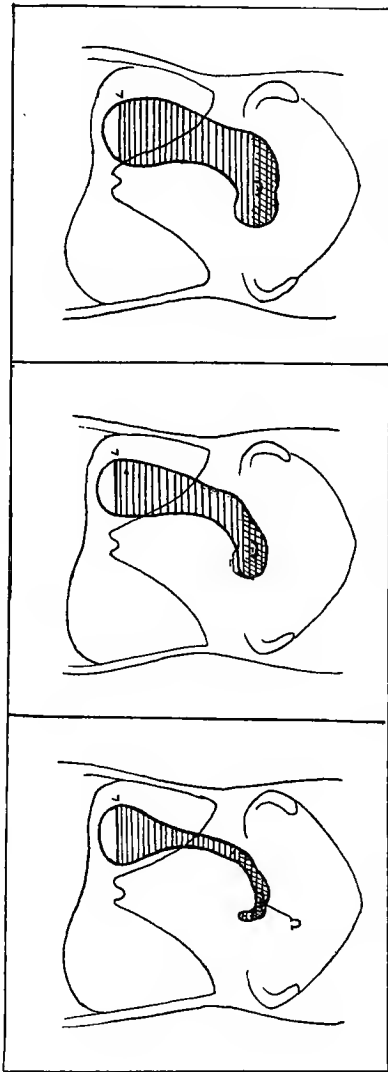

FIG. 191.—Diagrams of shadows of stomach after different quantities of fluid have been swallowed.

about midway along the greater curvature. As they pass slowly towards the pylorus they become steadily deeper, until about one inch from the entrance into the pyloric canal, the extreme pyloric end of the stomach is, as a rule, completely separated from the rest of the organ (Fig. 197). The part thus cut off gradually diminishes in size owing to the further passage of the peristaltic wave and the simultaneous contraction of its longitudinal muscle-fibres. Its contents can be seen to pass partly backwards as a reflux stream into the stomach and partly through the narrow pyloric canal into the duodenum.

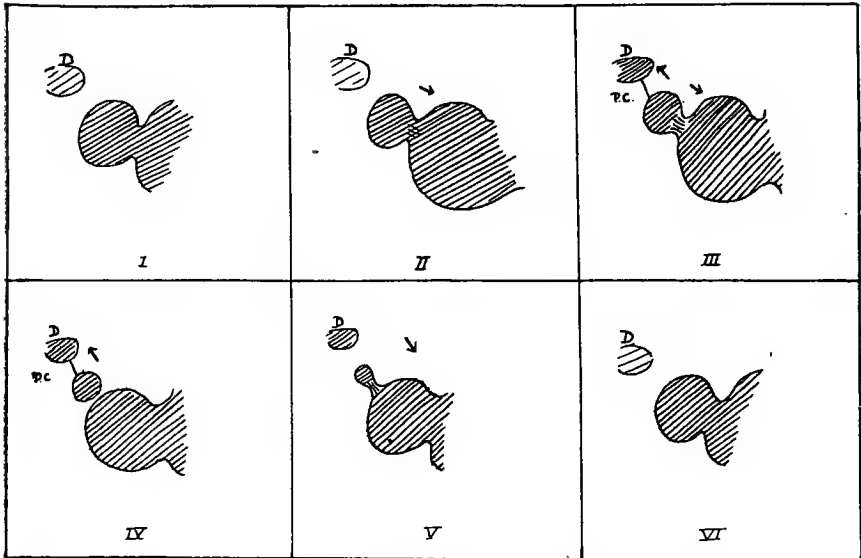

FIG. 197.—Peristalsis in the stomach.

Intestines.—The shadow of the duodenum cannot, as a rule, be very definitely seen, owing to the rapid passage of the bismuth out of it and the diminished concentration of the salt due to the large quantities of digestive secretions mixed with it. The motor activity of the small intestine can therefore only be satisfactorily studied some hours later.

A second examination should be made between four and five hours after the bismuth meal. The stomach is then generally empty. The shadow of the caecum is seen in the right iliac fossa, and in some individuals a small part of the ascending colon is also visible; the appendix can only be recognised on rare occasions. This examination shows that about four hours are required for the passage of food

through the small intestine. A diffuse shadow is generally present at this time in the pelvis. It consists of the terminal coils of the small intestine, the last few inches of which can often be recognised as they join the caecum. With a narrow diaphragm for the X-rays, short lengths of intestine can generally be clearly defined and their movements studied. A general forward movement of the shadow as a whole, due to peristalsis can be recognised. At the same time segmentation is seen to occur. The shadow of a short length of intestine, at first of uniform thickness, becomes constricted in its centre. The constriction increases until the single shadow is more or less completely divided into two. Then each half undergoes a similar division, the two central segments of the four produced by the second division joining together. The

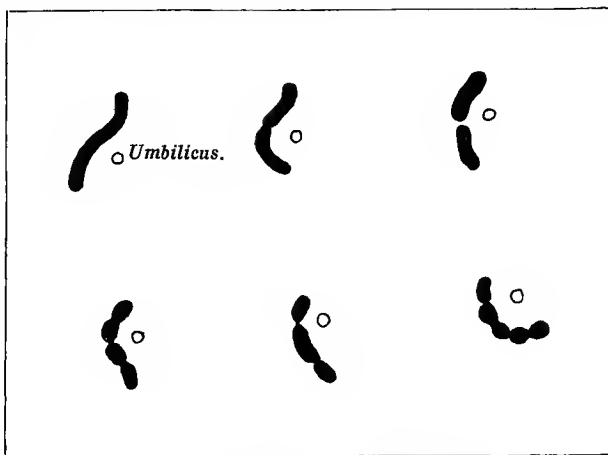

FIG. 198.—Segmentation of small intestine.

new central segment then divides again, the segmentation continuing at the rate of about seven divisions a minute. The process is shown diagrammatically in Fig. 198.

A further examination should be made on the following day as early in the morning as convenient. If possible, the bowels should not be opened before this examination. The whole of the large intestine is generally visible, and its position should be marked out in the vertical and in the horizontal position. In the horizontal position the transverse colon is approximately on a level with the umbilicus; in the vertical position it is considerably lower. Both the hepatic and splenic flexures are generally acute, especially in the vertical position, and the two limbs of the flexures may form a single shadow. The effect of straining, as it occurs in defaecation, should be observed: the

whole of the colon is greatly depressed, the caecum and ascending colon together forming a rounded shadow. Peristalsis is never seen, owing to the extremely slow progress of the waves.

The individual should now retire and open his bowels. On returning a tracing of the colon should again be made. The whole of the large intestine will be seen to have taken part in the act, even the caecum being less full than it was before. In most cases everything beyond the splenic flexure is evacuated in defaecation (Fig. 199).

The above description refers to an average case. Very considerable variations occur between different individuals; sometimes, for example, the whole of the bismuth is collected in the pelvic colon at the examination on the second morning, the rest of the colon being invisible.

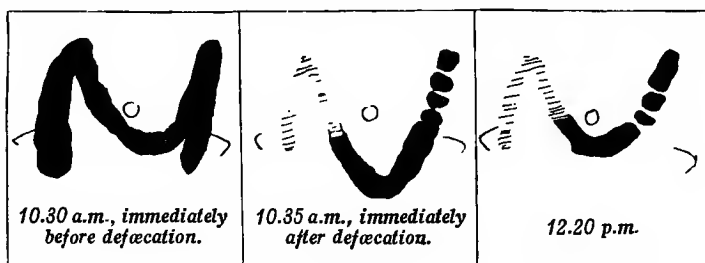

FIG. 199.—Defaecation.

Remarkable variations in the shape, size, and position of the different parts of the alimentary canal are also observed in perfectly normal individuals.

Care should be taken to expose the body, and especially the hands and the testicles, to the rays for as short a time as possible. So long as no part of the body is subjected to the direct action of the rays for more than ten minutes during the three examinations, it is unnecessary to wear any special protective covering.

CHAPTER LVIII.

SALIVARY SECRETION.

Salivary Secretion.—DEMONSTRATION. The submaxillary gland is situated within and a little behind the posterior angle of the lower jaw bone.

The animal anaesthetised with ether and chloroform is placed on its back, and its head extended. An incision is then made along the

internal border of the jaw bone. The internal border of the digastric muscle is thus exposed. This is pulled aside by a hook so as to expose the transverse fibres of the mylohyoid muscles.

The mylohyoid is carefully severed following the line of the digastric muscle. The submaxillary and sublingual ducts crossed by the lingual nerve are now exposed in the depth of the wound. Wharton's duct is the larger and external to the sublingual duct. Just where the lingual nerve crosses the ducts it gives off a small branch—the chorda tympani. In the angle formed by the origin of the chorda tympani from the lingual nerve there lies the sublingual ganglion (it is erroneous

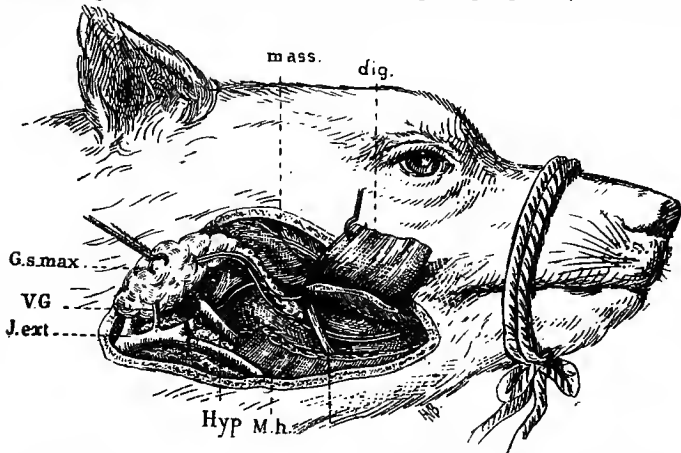

FIG. 200.—Dissection of the submaxillary (G.s.max) and sublingual glands and ducts and the lingual nerve L. The chorda tympani leaves the lingual and runs along the ducts. J.ext, external jugular vein; V.G, branch of vein to gland; Hyp, hypoglossal nerve; M.h., mylohyoid; dig., digastric; mass., masseter muscle. (Bernard).

to term this ganglion “submaxillary”). A ligature is placed beneath the lingual nerve, central to the origin of the chorda tympani, and the lingual nerve is divided central to the ligature. Two ligatures are passed under Wharton's duct, and one is tied. The chorda tympani is then tetanised and the duct filled with saliva. A V-shaped slit is then made into the duct, and a fine glass or silver cannula inserted and tied in.

The sympathetic fibres run into the gland with the arteries. To expose these the digastric muscle is divided close to its insertion on the jaw bone, and the posterior end of the muscle hooked back. A triangular cavity is thus exposed. The carotid artery with the nerves lie in the lower part of this, while Wharton's canal and the artery of the gland appear in the upper part. The gland itself lies a little more to the back.

On exciting the cervical sympathetic, or the sympathetic nerve filaments which accompany the artery of the gland, the gland will pale owing to vaso-constriction. A little thick secretion will at the same time appear in the cannula. On exciting the chorda tympani, an abundant secretion of thin watery saliva appears. At the same time the gland becomes red and turgid. The same effect may be produced reflexly by excitation of the central end of the lingual nerve.

The submaxillary gland is enclosed in a firm capsule. It is fed by a branch of the external maxillary artery which enters the hilus of the gland. The gland also receives small branches from the great or

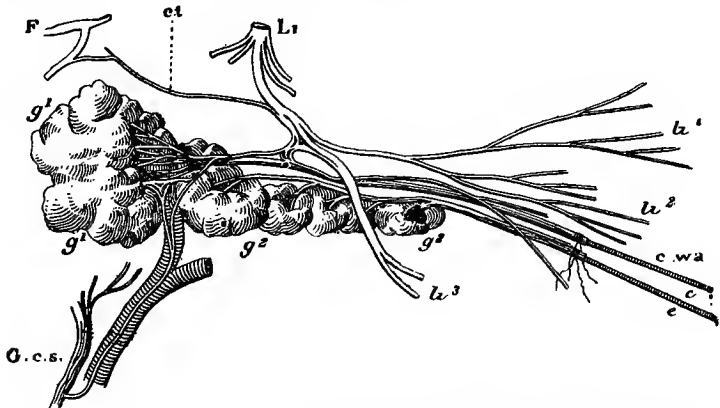

FIG. 201.—Diagram of the submaxillary and sublingual glands and ducts and their nerve supply from chorda tympani and sympathetic. F, facial; L¹, lingual; ct, chorda tympani; C.c.s., cervical sympathetic usrve; g¹, submaxillary; g², sublingual gland; c.w.a, e.c ducts of glands. (Bsrnard.)

posterior auricular artery. The veins are usually two, but are variable. One enters the internal and the other the external maxillary vein close to where these veins join to form the external jugular vein. The blood coming from the salivary gland can be collected by tying a cannula in the external jugular vein and ligating all branches excepting those coming from the gland. The exchange of blood-gases in the gland can thus be determined.

Nicotine, 30-40 mgrms. in dog, 10 mgrms. in cat, injected intravenously, paralyses the preganglionic fibres of the chorda tympani for about 15 minutes. The ganglion cells of the submaxillary gland are in or near the hilus of the gland.

Atropine sulphate, 10-14 mgrms. in dog, 5-15 mgrms. in cat, injected into the blood paralyses the secretory fibres of the chorda tympani, while it leaves the vaso-dilator fibres untouched. Pilocarpine nitrate,

1-2 mgrms., produces prolonged and plenteous secretion. The antagonism may be shown by injecting atropine into the blood and then injecting a little 2 per cent. solution of pilocarpine into the gland by way of the duct cannula.

If the duct cannula is connected with a mercury manometer and the chorda tympani stimulated, the secretory pressure will be observed to rise higher than the pressure in the carotid artery.

The submaxillary gland has been placed in a plethysmograph and its volume recorded (Bunch). Stimulation of the cervical sympathetic causes very considerable diminution in volume and a scanty secretion. Excitation of the chorda tympani is followed by diminution in volume in spite of vaso-dilatation. This is due to the copious secretion. After injection of atropine the volume is increased by chorda excitation.

When a cannula was placed in the cervical lymphatic just above where it enters the thoracic duct the effect of stimulating the salivary gland on the outflow of lymph was observed (Bainbridge).

Stimulation of the chorda or injection of pilocarpine increases the outflow of lymph $2\frac{1}{2}$ times. If Wharton's duct be obstructed the lymph flow is not so great. After injection of atropine no such increase is found. Stimulation of the sympathetic also increases the flow of lymph.

When a permanent salivary fistula is made, and the duct cannula is arranged to empty into a vessel attached to the dog's neck, it is found that the character of the secretion varies with the nature of sensory excitation (Pawlow). Stones placed in the dog's mouth are rejected without flow of saliva. Sand is washed out by watery saliva which contains almost no solid or ferment. Food provokes the secretion of saliva rich in ferment. The reflex and sub-conscious nervous mechanism which controls the secretion of saliva thus carries out actions which are similar to voluntary or willed actions.

NERVOUS SYSTEM.

CHAPTER LIX.

THE FUNCTIONS OF THE CENTRAL NERVOUS SYSTEM.

The Effects of Removal of both Cerebral Hemispheres.—In the frog the cerebral hemispheres contain only a single layer of nerve-cells and have reached only a very low stage of development. If the cerebral hemispheres be destroyed by rapidly compressing the anterior part of the skull between the blades of a pair of Spencer Wells' forceps



FIG. 202. —Diagram of the frog's brain. 1, Olfactory lobe; 2, cerebrum; 3, pineal gland; 4, thalamencephalon; 5, optic lobe; 6, cerebellum; 7, fourth ventricle and medulla oblongata.

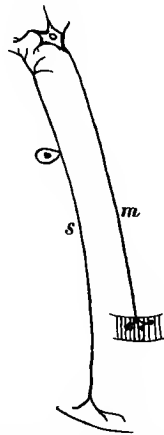

FIG. 208. —Diagram of a reflex arc, *m*=the motor nerve arising from a nerve-cell in the anterior horn of the spinal cord and ending by a motor end plate in a muscle; *s*=the sensory nerve arising from a nerve-cell in the posterior root ganglion and forming a series of dendrites around the motor nerve-cell above and possessing a sensory nerve ending in the skin below.

there will be no loss of blood and the optic thalami will escape injury. The first effect of the operation will be a general depression of the nervous system, a condition known as *shock*. This will quickly pass off and the brainless frog will show spontaneous movements, will swim if placed in water, will turn over if placed upon its back, and will behave generally as a normal frog.

If, however, the *corpora striata* and *optic thalami* be destroyed, the frog will show no spontaneous movements, will not feed, and will soon die unless the evaporation of water from its skin be prevented by placing it in a shallow plate filled with water and covered by a

bell-jar. The destruction of these portions of the central nervous system produces marked shock, but, after this has passed off, the frog will still be able to jump, swim, maintain its equilibrium, and perform other complicated and co-ordinated movements when it is stimulated in the appropriate manner.

The cerebellum and medulla oblongata are now destroyed by passing a blanket-pin through the foramen magnum of the skull, and by lateral movements of the pin breaking up the nervous tissue. The frog now lies in a limp, toneless condition; shock is well marked, and does not pass off quickly. The respiratory movements of the nares and of the floor of the mouth cease. The circulation of the blood is disordered by the destruction of the vaso-motor centre.

The "Spinal Animal."—The frog now possesses only its spinal cord, but it still shows co-ordinated movements. Its hind legs possess tone, and are drawn up against the flanks; if one leg be pulled away from the body, or be stimulated by pinching a toe, it will be withdrawn from the source of irritation. The movements are of a reflex nature, a response to a stimulus (Fig. 203).

When placed upon its back such a frog does not right itself, and when thrown into water it generally sinks to the bottom, and may or may not swim for one or two strokes.

If such a frog be suspended by the lower jaw, it does not move unless stimulated.

A small piece of filter-paper soaked in strong acetic acid will, if placed upon the skin of one flank, act as a stimulus, and the leg of the corresponding side will be raised to wipe off the offending body. If this experiment be repeated five minutes after the frog has been dipped in a beaker of water to remove the acid, and the leg be held down by the hand, then the leg of the opposite side will be raised in an apparent endeavour to wipe off the irritating piece of paper. The frog is again dipped in the beaker of water to remove the acid.

Turck's experiment upon the time of response of the spinal animal to a stimulus can now be performed. A small beaker is filled with dilute sulphuric acid (1 in 1000), and is gradually raised until the toes of one of the hind legs dip into the acid; this moment is noted, and then the interval between the application of the acid and the withdrawal of the toes is measured by a watch or a metronome (Fig. 204). After washing off the acid the

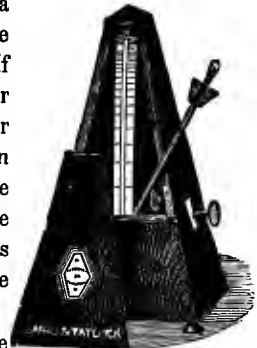

Fig. 204. —A metronome.

experiment is repeated with acid of the strength 1 in 500. In each case the time of response is much longer than the true time of a reflex action.

The Action of Strychnine and of Chloroform.—The cerebrum of a frog is destroyed by means of Spencer Wells' forceps, and then under the skin of the back are injected 10 minims of a saturated solution of strychnine (1 in 6700). In two or three minutes it will be noticed that the frog cannot readily recover its hind legs after a jump, and soon the reflex excitability of the spinal cord is so augmented that a slight touch or puff of wind upon the skin causes a general spasm of the muscles. Convulsions quickly follow, and the rigid body of the frog rests on the mouth and toes, a position known as *emprosthotonus*. This attitude is due to the different strength of the various muscles; all are thrown into contraction, but the stronger overcome the weaker. The muscles are somewhat relaxed after the spasms, but are again sent into tetanus by the slightest touch applied to the skin.

The *tonic* contractions are followed by prolonged twitches or *clonus*.

If during the stage of convulsions a probe be pushed down the vertebral canal, and thus the spinal cord be destroyed, the convulsions cease at once, showing that the strychnine acts upon the ganglion cells and their dendrites in the spinal cord. (See page 220.)

The action of strychnine should be contrasted with that of chloroform. Under the skin of the back of a frog, whose cerebrum has been destroyed by Spencer Wells' forceps, are injected 5 minims of chloroform. The first effect is one of stimulation, but this stage of excitement is quickly followed by marked inco-ordination and weakness. In about ten minutes there is marked anaesthesia, paralysis, and total absence of reflexes. If the frog be kept moist in a shallow plate full of water, and covered by a bell jar, it may recover from the effects of the chloroform in about eight or nine hours.

CHAPTER LX.

REACTION TIME.

THE time which elapses between the application of a given stimulus and the prearranged response of the subject to that stimulus is known as the reaction time. It is obviously more complex than a reflex action; this will be readily understood from a consideration of the following determination of the reaction time.

The diagram 205 shows W. G. Smith's reaction time apparatus as modified by Colls. The electro-magnetic tuning-fork, T, with 100

vibrations per second, is connected with two Daniell cells and with the chronograph C. By means of either of the two Du Bois keys, K_1 and K_2 , the chronograph can be short circuited. The key K_1 is closed and K_2 is open; the tuning-fork is set vibrating, but does not affect the chronograph. The subject, whose reaction time is to be determined, is told to listen for the sound of the opening of the key K_1 and to close the

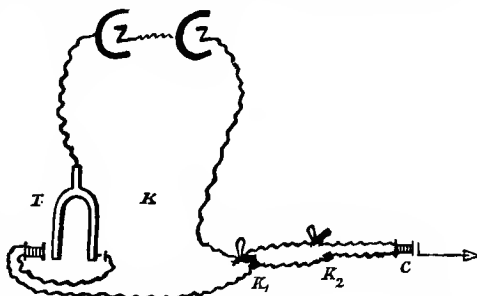

FIG. 205.—Diagram of the apparatus for the determination of reaction time.

key K_2 directly he hears the sound. When the key K_1 is opened the chronograph vibrates in unison with the tuning-fork and the vibrations are recorded upon a revolving drum; the closure of the key K_2 by the subject of the experiment brings the chronograph to rest. The number of vibrations recorded upon the drum gives the reaction time for sound in $\frac{1}{1000}$ ths of a second.

The total reaction time in this experiment is composed of—(1) the time taken by the sound to reach the ear; (2) the time taken for the reception of the stimulus by the sensory endings of the auditory nerve and the transmission of the nervous impulse to the sensory area; (3) the time for the transmission to the higher centres so that volitional impulses may be started in the cerebral motor centres; (4) the time for the propagation of those motor impulses to the nerve cells of the spinal cord; (5) the time required for the generation of impulses in these cells and their passage down the motor nerves to the muscles of the hand; and (6) the latency of the contraction of those muscles.

The reaction time for sound is about 0.150 second, for light 0.195 second, and for touch about 0.145 second.

CHAPTER LXI.

THE RATE OF DISCHARGE OF NERVOUS IMPULSES FROM THE CENTRAL NERVOUS SYSTEM.

THE rate at which nervous impulses can be discharged by the central nervous system can be investigated in the frog by exciting the nerve cells by means of a drug such as strychnine and recording the resulting incomplete tetanus; or in man by the record of the contraction of a

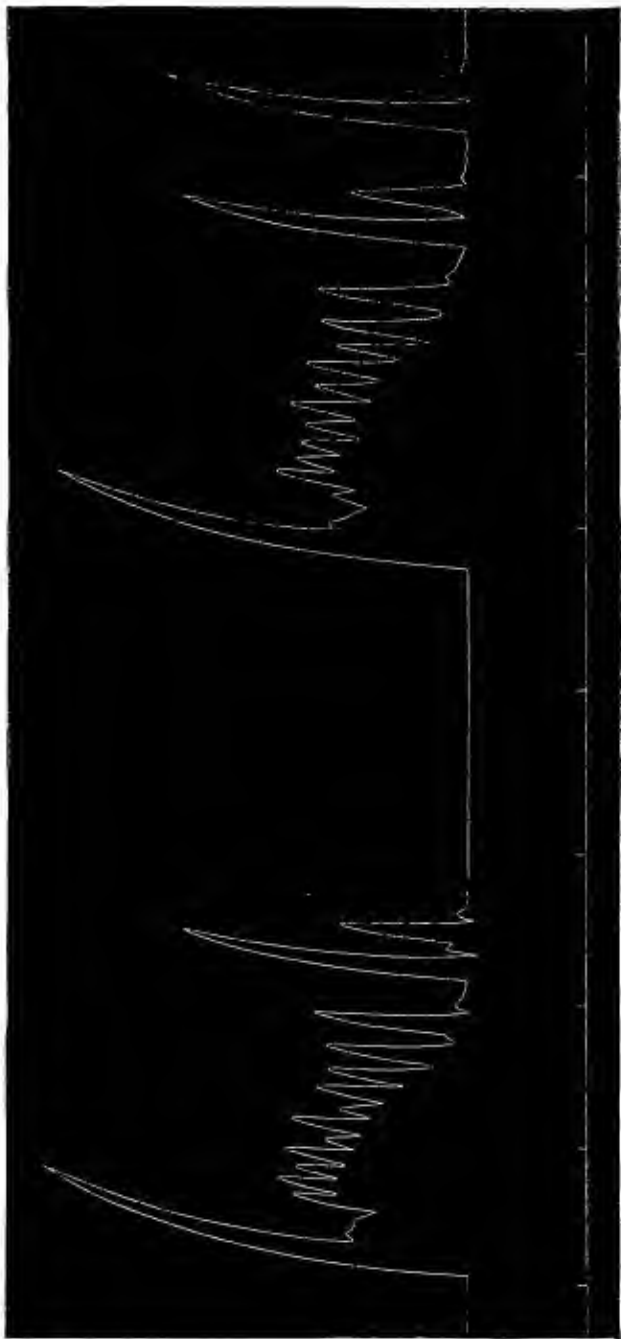

FIG. 206.—Tetanus of the gastrocnemius muscle produced by the action of strychnine upon the spinal cord of a brainless frog. The time is marked in seconds. Temperature of air = 23°. (Pembrey and Phillips.)

muscle thrown into contraction voluntarily, or involuntarily as in shivering.

(a) **The Incomplete Tetanus produced by Strychnine.**—The cerebral hemispheres of a frog are destroyed by compression with a pair of small pliers or Spencer Wells forceps, and then the gastrocnemius muscle is prepared with the circulation intact. A piece of string is placed under the gastrocnemius muscle and is then tightly tied round the upper portion of the tibio-fibula and the remaining muscles; the leg is now cut away below the ligature. In this manner haemorrhage is prevented, the circulation in the muscle is intact, and the muscle is free to move with each contraction. A strong pin is placed through the lower extremity of the femur and is pushed firmly into the cork of the myograph; a piece of moist flannel is pinned down over the body of the frog in order to prevent the contraction of the muscles of the trunk and limbs from disturbing the lever connected with the gastrocnemius muscle.

Strychnine is sparingly soluble in water, 1 in 6700, but a dose of 10-15 minims (0.592 – 0.888 c.c.) of a saturated solution of the drug in normal tap-water saline solution will in a frog produce the characteristic convulsions and death. Such a dose is injected under the skin of the frog's back. Twitches and convulsions soon begin and the contractions of the gastrocnemius muscle are recorded simultaneously with the movements of a signal marking seconds (Fig. 206). The number of contractions is about 8 or 10 per second. This is a measure of the rate of discharge of the nervous impulses from the nerve-cells of the spinal cord. The stage of incomplete *tetanus* is followed by prolonged twitches or *clonus*. If the spinal cord be destroyed by a probe during the stage of tetanus the contractions will cease at once,



FIG. 207.—Record of a voluntary contraction of the adductor pollicis. The time is marked in seconds.

showing that the convulsions were due to the action of the drug upon the nerve-cells and dendrites in the spinal end.

Record of a Voluntary Contraction.—If a finger be placed upon a muscle voluntarily thrown into contraction, a series of vibrations can be felt. These can be recorded and their rate determined in the following way.

A receiving tambour, with a button or a piece of cork fixed upon the rubber membrane, is connected with a bellows recorder (Fig. 208),

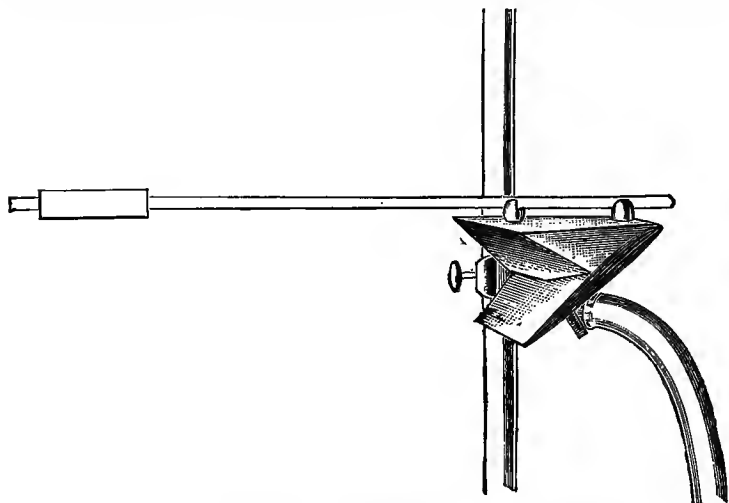

FIG. 208.—Brodie's bellows recorder. The bellows are made of aluminium plates and peritoneal membrane.

which is arranged to write upon a revolving drum. A chronograph is set up for marking the time in seconds. The button of the tambour is placed upon the adductor pollicis, or the masseter muscle of the subject. When the muscle is voluntarily contracted the lever shows a number of vibrations; these are recorded (Fig. 207). The curve obtained resembles an incomplete tetanus with 6 or 8 vibrations per second.

CHAPTER LXII

THE FUNCTIONS OF THE ANTERIOR AND POSTERIOR ROOTS OF THE SPINAL CORD. THE BELL-MAJENDIE LAW.

THE researches of Bell and of Majendie showed that the anterior roots of the spinal cord were motor, and the posterior were sensory; the former nerves are *efferent*, carrying nervous impulses from the spinal

cord to the periphery, the latter are *afferent*, carrying impulses from the periphery to the spinal cord. This law can be proved by experiments upon a brainless frog, but careful dissection and manipulation are necessary.

The following are the several stages in the experiment. A small pair of electrodes is made by passing the bared ends of two pieces of fine insulated wire through a piece of cork, and the induction-coil is arranged for single shocks. The cerebrum of a large frog is destroyed by compression with a pair of Spencer Wells forceps, and then the frog is placed belly-downwards upon a cork board, and is confined to this position by a piece of wet flannel fastened down tightly by pins. A slit is made through the flannel in the line of the vertebral column, and the skin is reflected as far as the end of the urostyle. The ilium is carefully removed on one side, care being taken to avoid cutting any large blood-vessels, for loss of blood would lower the excitability of the spinal cord and obscure the dissection. For a similar reason the medulla oblongata, which contains the vaso-motor centre, was left intact. After the removal of the ilium the nerves of the sacral plexus can be easily found and followed up to the spinal cord. Starting from the top of the urostyle the laminae of the vertebrae are carefully removed by scissors, the points of which should not be plunged deeply inwards, otherwise the spinal cord will be injured. After the removal of several laminae one of the large nerves of the sacral plexus is followed up to its intervertebral foramen, where a black swelling about the size of the head of a pin will be seen. This is the posterior root-ganglion. It is freed from the foramen by careful dissection, and the roots are traced therefrom to the spinal cord. Fine threads are placed under the roots, which are then divided in the middle of their length by clean sharp scissors.

Stimulation of the peripheral end of the motor root will cause a contraction of the muscles of the corresponding leg; stimulation of the central end with a weak induction shock will cause no movement. On the other hand stimulation of the peripheral end of the posterior root produces no movement, but a similar stimulus applied to the central end sets up a sensory impulse which produces reflex movements.

The roots of the spinal nerves are longest in the lower segments of the spinal cord; for this reason the experiment is most readily performed in this region. During development the vertebral column grows more quickly than the spinal cord, and thus the lower posterior root-ganglia in the intervertebral foramina are separated from the spinal cord by a longer length of nerve-roots than in the case of those supplying the upper limb.

CHAPTER LXIII.

MÜLLER'S LAW OF THE SPECIFIC ENERGY OF NERVES.

The Law of the Specific Energy of Nerves propounded by Johannes Müller states that each sensory nerve gives rise to its own particular sensation, whatever may be the means whereby it is excited. Thus the retina only gives a sensation of sight, whether it be stimulated by light, a blow or an electrical shock.

This law can be demonstrated by the following experiments.

Sight.—(i) Two clinical electrodes moistened with strong saline solution are connected by means of a key with a Daniell cell; one electrode is placed upon the forehead, the other upon the nape of the neck. On make or break of the constant current the subject will have a sensation of a flash of light.

(ii) The retina can be stimulated mechanically by pressure on the sclerotic. A sensation of light will be experienced.

Taste.—The end-organs of taste can be stimulated not only by sapid substances, but also by mechanical and electrical means. (i) Gentle tapping of the front of the tongue gives a sensation of a sweet taste.

(ii) When the free ends of two wires connected with a Daniell cell are placed upon the tongue and the current is opened or closed, a sensation of taste is experienced. This experiment can be performed with suitable unpolarisable electrodes, so that the objection, that electrolysis is produced and the resultant ions are tasted, may be considered negatived. Moreover, weak faradising shocks, which would cause but little electrolytic action, also give rise to sensations of taste.

The anode appears to produce an acid taste, the cathode an alkaline taste.

Smell.—The olfactory nerve-endings give rise to a sensation of smell when they are stimulated with an electric current. The experiment can be performed in the following way. The electric current is sent through the nose by one electrode connected with the nose by filling the nasal cavity with normal saline solution; the other electrode is placed on the forehead. The odour is said to resemble that of phosphorus.

Cutaneous Sensations.—Sensations of touch, cold, warmth, and pain can be evoked by gentle application of the point of a metal rod to the skin of the hand. The areas or spots which on stimulation give rise to the different sensations should be mapped out with ink.

Mechanical stimulation with a metal rod warmed to the same temperature as that of the skin of the hand will give rise to sensations of touch, temperature, or pain according to the area stimulated. Müller's law is thus demonstrated in the case of these sensations.

There is some doubt whether there are specific nerves for painful sensations; it may be that excessive stimulation of any sensory nerve causes pain.

CHAPTER LXIV (*Advanced*).

CUTANEOUS SENSATIONS. SENSATIONS DERIVED FROM MOVEMENTS.

THE sensations which arise from stimulation of the sensory nerves of the skin include four separate qualities. These cutaneous sensations may therefore be divided into (*a*) sensations of pressure, (*b*) sensations of warmth, (*c*) sensations of cold, (*d*) sensations of pain.

On the other hand, surfaces in the interior of the body, such as the membranes of the alimentary canal, etc., furnish only sensations of pain, which are bound up with sensations referred to the skin, *referred pain*. The defensive mechanism connected with pain has been designated *protopathic*, and is of a lower developmental type than the mechanism which furnishes us with the means of making the fine discriminations of touch and temperature. This more highly specialised mechanism has been designated *epicritic*. It has not yet been found possible to definitely connect these different forms of sensations with different varieties of sensory nerve endings.

By simple experiments it is easy to show that the arrangement of the machinery which originates these sensations is not regular and continuous, an important feature being the *punctiform* distribution of the cutaneous senses.

I. METHODS ADAPTED TO ASCERTAINING THE DISTRIBUTIONS OF THE CUTANEOUS SENSES.

a. The sense of pressure.—It is necessary to distinguish between those lighter pressures which affect practically only the epidermis and the heavier pressures which can excite the subcutaneous tissues. Only the first of these can be strictly considered to be concerned in the sensation of *touch*.

EXPERIMENT I. Define an area of the skin, for example, on the volar surface of the forearm, about 5 cms. square. Carefully work over this area with a small camel's hair brush,¹ lightly touching adjacent small areas and marking with coloured ink the places where the contact is felt. The subject of the experiment should close his eyes, the observer marking the spots according to the replies of the subject. Instead of a camel's hair brush, a fine hair fixed to the end of a match may be used.

b. The sense of temperature.—Bodies at a lower temperature than the skin give a sensation of cold, at a higher temperature a sensation of warmth. The distribution of these two senses of temperature is not identical.

EXPERIMENT II. The most convenient way of testing for cold or warm spots is to take several soldering irons, the points of which have been filed down to give a surface of about a square millimetre. These are kept in water at the desired temperature till required. Or, a hollow copper rod, through which a circulation of water at the desired temperature is arranged, may be adopted.

As in Experiment I. explore the defined area of skin for responses to the different contacts in respect of heat or cold. The temperature should not be extreme, about 10° above or below that of the surface of the skin is sufficient. At extreme temperatures (*e.g.* 70° C.) other sensations come into play. Mark out the distribution of heat and cold spots in inks of colours different from that used in Experiment I. It may be observed that the temperature spots are readily fatigued.

c. The sense of pain.

EXPERIMENT III. Some form of algometer is required for the purpose of stimulation. Bristles, pointed with a razor, fixed in a light wooden rod, an ordinary mounting needle, or perhaps best, a needle fixed to the end of a bristle, are alternative forms of algometers. The amount of pressure used is of consequence, and to keep this constant the degree of bending of the bristle should not vary. Mark out the pain spots with distinctive ink.

It will be found in the above experiments that there is a lack of identity in the spots, corresponding to the different sensations, but if the marks be allowed to remain for some hours and again the sensations are tested, there will be found no alteration of position.

¹ Such a brush should be .5 cm. in length and forming a bundle not more than .05 cm. at the base.

II. METHOD ADOPTED FOR TESTING TACTILE SPATIAL DISCRIMINATION.

If the skin be touched simultaneously by a pair of compasses the points of which are separated, the distance that these must be apart in order to appreciate the doubleness of the contact varies in different parts of the skin. Special instruments possessing two points, the distance between which can be adjusted, are called aesthesiometers.

EXPERIMENT IV. Using either a pair of compasses (the points of which are guarded with small pieces of cork) or some form of aesthesiometer, note the smallest distance apart the two points must be in order that the two contacts may be appreciated, in the case of the tip of the tongue, tip of the middle finger, the palm of the hand, the forehead, the back of the hand, and the back.

SENSATIONS DERIVED FROM THE CONTRACTIONS OF MUSCLE AND FROM THE ACCESSORY STRUCTURES OF MOVEMENT.

Nerve endings exist in muscles, tendons and joints, and these are liable to be affected by the contraction of muscle, and the tension of the tissues adjoining thereby initiated. It is convenient to speak of the resulting sensations as brought about by the mediation of a "*muscular sense*."

EXPERIMENT I. Gun cartridges, filled with shot, are made up to different weights. Test the power of discriminating a difference in two weights when the absolute weights are small and where comparatively great. It will be found that when the weights are low the perceptible differences between two weights is much smaller than when the weights are great.

This is in agreement with Weber's law, which lays down that the just recognisable difference between two weights is not a constant for any person, but a constant fraction of the weight lifted. Roughly speaking, an increase of 10 per cent. on a weight is just recognisable.

THE PHYSIOLOGY OF VISION.

CHAPTER LXV.

THE DISSECTION OF THE EYE.

THIS can be conveniently carried out on the fresh eye of an ox or sheep.

1. Notice in the front of the eye the transparent circular area, the **cornea**, continuous with the greyish opaque border, the **sclerotic**. This coat is continued over the sides and back of the eye, but will be found covered with fat. The external eye muscles may be traced in the fat, and their tendinous insertion seen in the front part of the sclerotic. The optic nerve will be seen penetrating posteriorly. The greyish surface of the sclerotic in front is covered by a thin membrane, the **conjunctiva**, which is continued as a lining for the eyelids.

2. Having removed the fat from a portion of the upper surface of the eye so as to expose the sclerotic, make a pair of incisions passing along the surface from before backwards, and starting a few millimetres behind the corneo-sclerotic junction, let these incisions meet posteriorly. Then carefully peel up the sclerotic towards the cornea. Observe the dark underlining of the sclerotic, the **lamina fusca**. Note the **choroid** now exposed, and anteriorly observe that it is covered by a number of pale fibres passing forward to the corneo-sclerotic junction, forming the **ciliary muscle**.

3. Remove carefully the piece of the choroid lying exposed, and note a pale membrane lying beneath, the **retina**.

4. Place the eye in a glass basin of water, and make an incision right round the eye through all the coats, so as to separate the posterior from the anterior half. Examine the posterior half in the water. Note the thin retina floating away from the choroid, eccentrically in this the **optic disc** where the optic nerve enters the eye, and the blood-vessels radiating from this region. The **vitreous humour** of jelly-like consistency will remain attached to the anterior half of the eye. Looking through this, note the **crystalline lens**, at the side of this the radial folds of the choroid forming the **ciliary processes**. The thick portion

of the retina can be traced as far as these processes, where it terminates with a wavy edge, the **ora serrata**.

5. Remove carefully the vitreous humour, and note that it adheres to the ciliary processes by its outer coat, the **hyaloid membrane**. On removing the vitreous from the more central portion, note that it appears adherent to the posterior surface of the lens. The posterior layer of the lens capsule is continuous with the hyaloid membrane. If necessary, cut away the vitreous humour so as not to dislocate the lens.

6. Make a radial incision from the edge of the sclerotic down to the edge of the lens. Carefully separate the iris and ciliary region from the lens, and the **suspensory ligament** will be seen passing from the ciliary body mainly towards the front surface of the lens. Carefully separate the lens from this, and the suspensory ligament continuous with the capsule of the lens will float up away from the iris.

7. Cut round the upper half of cornea near its junction with the sclerotic. The **anterior chamber** will be exposed containing a clear fluid, the **aqueous humour**. Note the thickness of the cornea. At the back of the anterior chamber is seen the black curtain of the **iris**, with its central aperture the **pupil**.

8. Notice that the fresh vitreous humour and lens when placed in water are not easily seen; they have almost the same refractive index as water. After death the lens slowly becomes turbid.

9. Hold up the lens and look through it towards a lighted match; it will give an inverted image.

10. Notice the segmentation of the lens; it is peculiar, and may be roughly compared to a segmentation similar to that of an orange combined with the concentric lamination of an onion.

CHAPTER LXVI (*Advanced*).

THE EYE AS AN OPTICAL INSTRUMENT.

Preliminary Consideration of the Mechanism of the Eye.—In order to understand the refraction of the rays proceeding from external objects and forming images on the retina, it is necessary, in the first place, to briefly consider the nature of such an optical system as constitutes the refractive apparatus of the eye.

The simplest form of an optical system consists of two media of different refractive powers separated by a spherical surface (Fig. 209).

If dpe be such a surface, separating a less refractive medium S from a more strongly refractive medium R , n is the centre of curvature, and is called the “nodal point.” If p be the vertex of the curved surface, a line through p and n will form the optic axis OA . Rays parallel to OA proceeding from S will be conveyed to a point F_2 on the optic axis. This point is called the **posterior principal focus**. Rays parallel to OA proceeding from R will be conveyed to a point F_1 , the **principal anterior focus**. p is spoken of as the **principal point**. These two foci, the principal point and the nodal point, constitute the **cardinal points** of such a system.

In the actual eye the arrangement is not so simple, as there are several refractive media, and three separate surfaces—the anterior surface of the cornea, the anterior surface of the lens, and the posterior surface of the lens. The arrangement of these is, however, symmetrical, and permits of the reduction to two ideal surfaces for the three actually existing. This brings the number of cardinal points to six, as each of these surfaces will possess its own nodal point and principal point, though the anterior and posterior foci will be identical.

But for practical purposes a further simplification is possible. The two nodal points are not far separated, and the two principal points are similarly very near, being distant only about .4 mm. from each other. We therefore take a “mean” nodal point and a “mean” principal point and again reduce the optical conditions to those of a simple optical system, consisting of one (ideal) refractive surface. In such a “reduced eye” the cardinal points are as follows:—

Principal point.—2.3448 mm. behind the anterior surface of the cornea, in the aqueous humour.

Nodal point.—4764 mm. in front of the posterior surface of the lens.

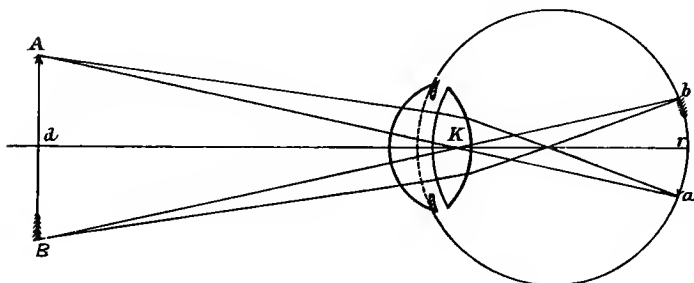
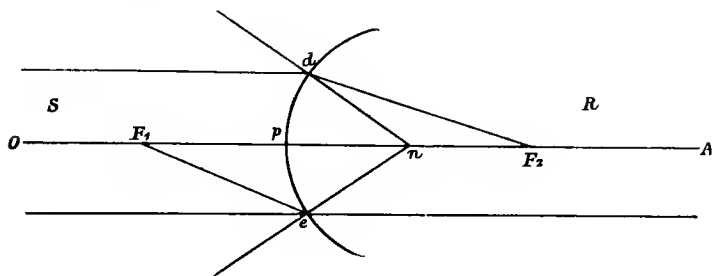

FIG. 200.—Diagrams to illustrate refraction.

Posterior principal focus.—22·647 mm. behind anterior surface of the cornea.

Anterior principal focus.—12·8326 mm. in front of the anterior surface of cornea.

Radius of curvature of ideal surface, 5·1248 mm.

With these data we are now able to understand the formation of the image on the retina, and are able to calculate the size of the retinal image of an object.

A ray passing through the nodal point *K* (Fig. 240) will not undergo refraction, and therefore will indicate the position of the image of any external point upon the retina. It follows also that the *size of the actual image* may be calculated if we know *AB* (the size of the external image), *dK* its distance from the nodal point. For

$$\frac{ab}{Kr} = \frac{AB}{dK}$$

But dK = distance of object from cornea + distance of nodal point behind cornea, which latter is equal to 7.44 mm.

Kr is equal to 15.17 mm.

$$\therefore ab = \frac{\text{size of external object} \times 15.17}{\text{distance of object from cornea} + 7.44}$$

If the image be near so as to provoke a considerable effort of accommodation, this equation will not represent the size of the formed image. In this case the anterior surface of the lens will be more curved than in viewing more distant objects, and consequently the constants for the "simple reduced eye" will not hold good. The "reduced eye" of Listing corresponds, strictly speaking, to the lens accommodated for distant objects.

The Ophthalmometer.—This is an instrument by means of which the radius of curvature of the different surfaces of the eye may be measured. The degree of curvature of a reflecting surface will affect the size of the image formed from some external object. If some device be applied for the measurement of the image and the distance of the external object from the reflecting surface be known, then the curvature of the reflecting surface can be calculated.

In Helmholtz's original form of the ophthalmometer the measurement of the image was achieved by causing the rays reflected from the cornea to undergo deviation from their direct course by passing through glass plates of a definite thickness. By introducing two glass plates, revolving in a common vertical axis, two images could be obtained, and the degree of overlapping of these images could be adjusted by altering the angle which the two plates made with one another. The distance between corresponding points in the two images could be expressed in terms of the angle representing the degree of tilt of the plates and the refractive index of the glass. The greater the obliquity of the plates the more considerable would be the displacement of the images.

Having obtained a value for the size of the reflected image the curvature of the cornea could be calculated from the equation,

$$\frac{\text{the size of a luminous body } (L)}{\text{size of its reflected image } (I)} = \frac{\text{distance of body from cornea } (d)}{\frac{1}{2} \text{ radius of cornea } (\frac{1}{2}r)}$$

$$\text{or} \quad r = \frac{2d \times I}{L}$$

A modification of Helmholtz's ophthalmometer was introduced by Javal & Schiötz, in which the double glass plate was replaced by a calc-spar crystal and a similar double image obtained. This was still further improved by Kagenaar, who substituted compound prisms for the crystal, and the instrument so cheapened and improved is generally spoken of as an *astigmatometer*. This instrument, which is essentially an ophthalmometer, is represented in Fig. 210.

It consists of a telescope, which is directed towards the subject's eye, the head of the subject rests in the frame, opposite the telescope. The eyepiece of the telescope is first adjusted by focusing a thread which lies in the plane of the image formed by reflection from the cornea.

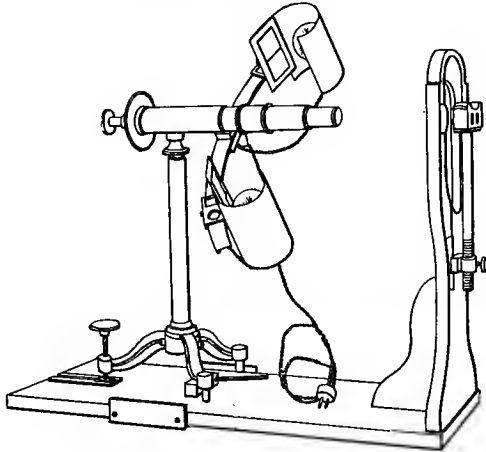

FIG. 210. —The ophthalmometer.

This adjustment is carried out by turning the telescope towards a milk glass plate on the left of the subject, and moving the eyepiece till the thread is defined. The telescope is then directed towards the subject's eye, and moved with its stand backwards or forwards towards the observed eye till either of the reflected images of the illuminated areas on the quadrant is clearly defined. In the quadrant is a fixed area opposite a white line corresponding to the number 20 on the scale. Let the quadrant be first placed in a horizontal plane, with the fixed illuminated area to the left. According to the varying position of the right illuminated area two pairs of images will now be seen reflected from the cornea, and attention should be directed to the two middle of these images, which may or may not overlap (Fig. 211). The right moveable area should now be adjusted on the quadrant so that the edge of one image just touches the edge of the other, the 'stepped' image being to the left and the rectangular area to the right. A white line on the back of the right illuminated area will now point to some number on the scale; when the images are adjusted as above, this number + the 20 corresponding to the position of the left illuminated area, will express numerically the degree of curvature of the cornea. According to the constants of the instrument if the number 337 be divided by the number expressing the curvature of the cornea as above, the quotient represents

the radius of curvature of the cornea in the horizontal meridian examined. The use of the instrument for measuring astigmatism may here be detailed.

EXPERIMENT. Method of Measuring Astigmatism.—By the use of the ophthalmometer represented in Fig. 211 the difference of curvature of different portions of the cornea can be easily ascertained.

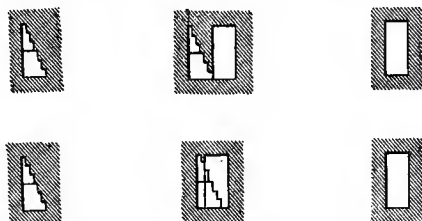

FIG. 211.—The images in the astigmometer.

The apparatus is adjusted as described above, and the horizontal meridian is first observed. If the curvature in this meridian is regular the four figures will be seen to stand on a level base. If this is not the case, the rotating quadrant must be moved till continuity of base line is obtained. The moveable illuminated area is then adjusted till the four reflected images are as in the figure.

The quadrant is then rotated, and as it approaches the vertical the two central images will probably overlap. Note the meridian where the greatest amount of overlap is observed. This will be the most refracting meridian. Each tread of the steps in the illuminated area corresponds to *one dioptré*¹ of curvature. The excess of curvature of the most refracting meridian may thus be read off at once.

CHAPTER LXVII.

THE REFRACTING MEDIA OF THE EYE.

Kühne's Artificial Eye.—The nature of the refraction produced by the various media of the eye is conveniently illustrated by means of this instrument (Fig 212). It consists of an oblong box, one of the long vertical sides being generally made of opaque material, the other of glass. The front end of the box is bounded by a curved glass surface, the hinder end is a plane sheet of glass. Various accessories are supplied with the instrument, such as a double convex lens which can be placed in the axis of the box behind the cornea, a frosted glass

¹A lens in which the focus for parallel rays is at one metre is taken as the standard lens, and its degree of refractive power is represented as one dioptré.

screen which is used as a receiving surface for the refracted rays, and an opaque screen with a central hole.

The box is first filled with water, and in order to make rays of light the clearer, a few drops of some fluorescent solution (*e.g.* eosin) are added to the water. An external luminous object is then arranged. This may be conveniently done by placing a metal plate, in which a vertical arrow has been stencilled out, in front of a good source of light, such as the naked arc light of an electric projecting lantern, with the condenser and focussing lens removed. This stencilled plate is placed four or five feet from the front of the instrument.

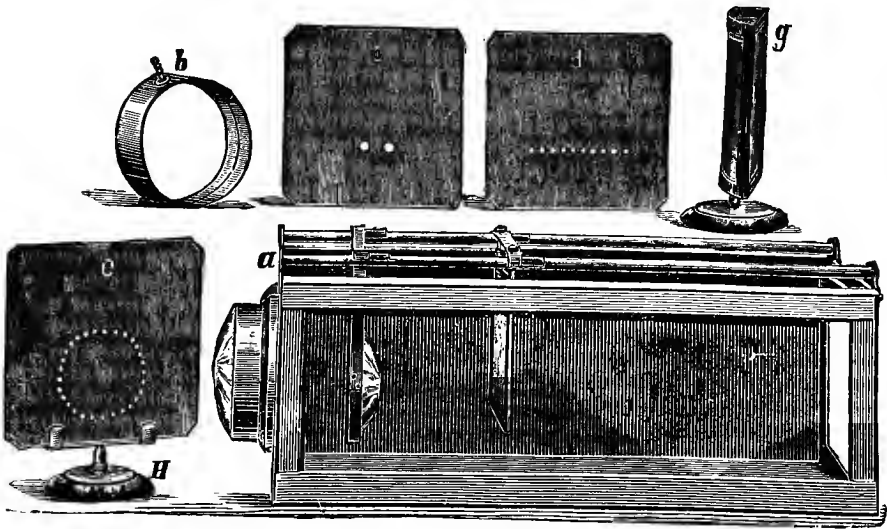

FIG. 212.—Kühne's artificial eye.

1. **The Action of the Cornea.**—If the illuminated arrow be placed approximately in the optic axis of the artificial eye, the rays of light will be seen passing through the box and converging somewhat in their progress. If the frosted glass screen be placed in the box, however far back it be arranged, no image of the arrow will be obtained. If, however, a screen be placed some distance behind the box an image will be formed. We have here illustrated the fact that without some specially strong refracting medium in the eye, external objects would be focussed behind the position of the retina and therefore not clearly visible. This is the case after the operation for cataract in which the crystalline lens is removed.

2. **The Action of the Crystalline Lens.**—Let the double convex lens supplied be now placed in the box at the front end. This at once

causes a much greater convergence of the rays, and it will be possible to obtain an image of the arrow upon the frosted glass screen, when this is placed about three inches from the hinder end of the box. This image may be easily seen on looking obliquely through the glass end, or may be projected by a convex lens on a lantern screen sufficiently clear for a number of observers to see.

3. **The Action of the Iris.** The iris improves the definition of the image by cutting out the more circumferential rays which in consequence of spherical aberration would not be focussed in the same plane as the more central. If the opaque screen having a central hole about an inch and a half in diameter be placed in front of the convex lens the total amount of light passing behind the lens is decreased, but the image is now much more sharply defined.

4. **The Position of the Image.**—It will be noticed that if the illuminated arrow point upwards the image on the artificial retina will point downwards. Images on the retina are therefore always inverted, the lower half of the retina corresponding to the upper half of the field of vision and conversely. By experience we always refer images on the retina to their proper position in the field of vision. This rectification corresponds to what is done by the second convex lens in projecting the retinal image upon the lantern screen. The effect of this second lens is to re-invert the image, so that on the lantern screen the image appears in the same position as in the original object.

5. **Accommodation.**—It is not possible with the artificial eye to mimic the changes that occur in the lens on accommodation. A clear image of objects at different distances can only be obtained by shifting the artificial retina backwards or forwards.

ACCOMMODATION.

1. The eye is able to see objects at varying distances from the eye. It has the power of adapting itself so as to form a clear image on the retina of different objects. Unless the eye had this power images of external objects at different distances would not always be formed at a constant distance behind the crystalline lens, where the retina is situated.

EXPERIMENT. Standing about 15 feet from a window and looking towards it, hold up a needle about two feet from the eye. If the needle be seen clearly the window sashes will be blurred, since the image of these will be in front of the retina. If the window sashes be looked at and seen clearly then the needle will be blurred, since the image of this is behind the retina.

2. **Range of Accommodation.** **Determination of Near and Far**

Points of Accommodation. Line of Accommodation.—At a certain distance close to the eye the power of accommodation is lost.

EXPERIMENT I. Hold a needle about 2 feet from the eye and gradually bring it nearer; it is for a certain time possible to obtain a clear image. At a certain distance, in spite of effort, the image begins to get blurred. The least distance at which one obtains a clear vision of the needle corresponds to the *near point* of accommodation. This is generally about 8 inches. In short-sighted persons a *far point* of accommodation may also be shown. If the distance between the two objects be not too great, although they are both in the line of sight, they may be seen clearly at one and the same time. That is to say that accommodation of a certain degree will enable the observer to see objects at varying distances from the eye. The maximum distance at which two objects in the line of sight may be separated will vary with the distance of the nearer of them to the eye. As the nearer object recedes from the eye the **line of accommodation** or the distance between the two objects increases.

[**ADVANCED EXPERIMENT.** Place two pins in the line of sight and note the distance apart at which they are both visible as single objects at the same time. Make observations with the nearer at 20 cm., 50 cm., 2 m. It will be found that the line of accommodation lengthens with a greater distance from the eye.]

3. Formation of Image in Excised Eye.—The excised eye is accommodated for objects at a distance.

EXPERIMENT. Remove the sclerotic and choroid from a fresh sheep eye, and place it, cornea outwards, at the end of a cylinder of brown paper. Direct it towards the window, and on looking down the tube an inverted image of the window will be seen.

This experiment can be still more easily performed on the eye of a freshly-killed albino rabbit, which, for convenience of handling, should be fixed in a ring of modelling wax or clay. In this case the sclerotic and choroid are sufficiently thin to obviate the necessity for their removal.

4. Action of Iris in Accommodation, and its Changes with Variations in Amount of Light.—The iris cuts off the more peripheral rays impinging on the cornea, otherwise the clearness of the image on the retina would be diminished. This is especially the case when viewing near objects, as here the angle of incidence of the circumferential rays is greater.

EXPERIMENT I. In not too bright a light direct the subject's attention from a far to a near object. It would be noticed that the pupil becomes smaller.

EXPERIMENT II. Make the subject close one eye and shade the open eye from the direct light. Observe the size of the pupil when the eye is shaded. Then remove the shade; the pupil will be seen to diminish in size. From this experiment it may be inferred that the amount of light entering the eye is controlled by the iris.

[**ADVANCED EXPERIMENT.** Make a pinhole near the edge of a card, and hold the card about 15 centimetres from the right eye, so that it does not interfere with the field of the light. Let a good source of light be placed about 60 centimetres from the eye, and allow a thin paper-screen to shield the light from the right eye. The left eye, when open, will look directly at the light, the right eye at the pinhole, and the illuminated paper through the hole. Close the left eye, and accommodate as nearly as possible for the distance of the pinhole. Note the size of the hole. Then alter the accommodation by attempting to look far away through the pinhole: The hole will immediately become distinctly larger, though less definite, on account of the blurring of the edges. Keep varying the accommodation, and the edge of the hole will similarly vary.

Whilst accommodated for far distance open the left eye. The sudden entry of light in the left eye will cause reflexly a diminution in size of both pupils. The pinhole will now become smaller. Close the left eye again and it enlarges. The size of the blurred image of the pinhole depends upon the size of the pupil, and hence variations in size of the pupil appear as variations in size of the pinhole.]

5. The changes in the Lens during Accommodation. Purkinje Sanson Images.—During accommodation for a near object, the ciliary muscle contracts, with the consequence that the suspensory ligament is slackened. The lens by its natural elasticity becomes more curved in its anterior aspect, and its thickness through the optical axis is increased. This change of curvature can be measured by means of the ophthalmometer. The existence of such a change may be inferred from the following experiments in which observations are made upon the images reflected from the anterior surface of the cornea, the anterior surface of the lens, and the posterior surface of the lens.

EXPERIMENT I. (PRELIMINARY). In a dark room place on a table, rather to the right of the observer, a convex lens mounted on a stand. Hold a watch glass a few inches in front of the lens, with the convex surface of the glass forward. Still more to the right let a lighted candle be placed. The candle and the observer's eye should be symmetrically arranged on either side of the optic axis of the lens and watch glass. Observe the images reflected from the surface of (*a*) the watch glass; (*b*) the anterior surface of lens; (*c*) the posterior

surface of lens. The images at (*a*) and (*b*) are erect; at (*c*) is inverted; the image at (*b*) appears to be the most deeply situated of the three.

EXPERIMENT II. In a darkened room let the observer bring a lighted candle near the eye of the subject, rather to one side of his optic axis. The observer places himself so that his eye is symmetrical in position to the candle on the other side of the optic axis of the subject. When properly adjusted there should be observed reflected from the eye of the subject three images the first bright and erect, reflected from the cornea; a second near the centre of the pupil, but much feebler than the first, and apparently the most deeply situated of all the images, this being reflected from the anterior surface of the lens; a third image represented by a mere spot of light differs from the other two in being inverted. If now the accommodation of the subject be shifted from a far to a near point, the middle image will advance but grow smaller, and will approach the corneal image. The other images do not alter.

During varying accommodation it is found that this image is the only one to change, thus indicating that the change is in the anterior surface of the lens.

EXPERIMENT III.—**The Phakoscope.**—This instrument is specially adapted for viewing the reflected images of Experiment II. It is represented in Fig. 213. Fig. 214 represents diagrammatically the arrangement and course of the rays of light. It consists of a dark box, roughly triangular in shape, with the angles of the triangle bevelled off, and at *S* and *O* fitted with windows (Fig. 214).

The observer's eye is at *O*, the subject's at *S*. At *C* two prisms are arranged vertically so as to allow two illuminated squares to fall upon the eye at *S*. The eye at *S* can either be focussed for the vertical needle at *W*, or (since this lies in an opening) for distant objects beyond the opening. With the alteration of the lens corresponding to the change of accommodation, the images from the anterior surface of the lens will vary as in Experiment II.

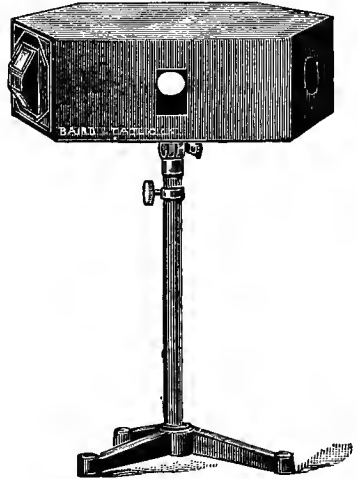

FIG. 213.—The phakoscope.

6. **Scheiner's Experiment.**—If the eye be accommodated for an object at any particular distance, the effect of preventing the retina

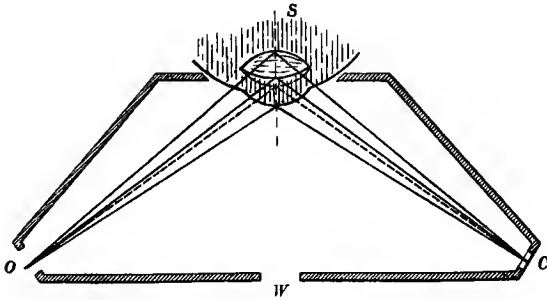

FIG. 214.—Diagram of the course of the rays of light in the phakoscope.

receiving all the rays from the object (as by a screen with holes pricked in it and held close to the cornea), is simply to diminish the brightness of the image, on account of the lessening of the amount of light entering the eye. Any object at a distance for which the eye is not accommodated will form a blurred image on the retina, and if rays from the object by this partial screening of the retina have several paths by which to impinge on the retina, there will be formed upon the retina as many blurred images as there are openings in the screen. When, however, the eye is accommodated for this second object, these blurred images fade into one clear image.

EXPERIMENT I. To form a screen take a thin piece of cardboard and prick two holes in it, separated by less than the diameter of the pupil. About one-sixteenth of an inch will answer. Place in a strip of wood about a yard long two vertical needles, distant eight and twenty-four inches from the eye. Close one eye and with the other, holding the screen close to cornea, look at one of the needles. The other needle will be also seen, but represented by a double blurred image. If the more distant needle be accommodated for, a double blurred image of the nearer will be obtained. Cover one of the holes in the screen with another card. If the right hole be covered the left blurred image will disappear, and conversely. Let the eye be now accommodated for the nearer image. A double blurred image of the more distant needle will be seen. If the right hole of the screen be now covered the right blurred image will disappear, and conversely.

EXPERIMENT II. A slight modification of this experiment and the material requisite is provided in the Milton Bradley Pseudoptics, Section I., exp. 4.

EXPERIMENT III. Experiment I. can be most instructively performed with Kühne's Artificial Eye. A special screen for the experiment is provided in which one hole is covered with red mica. Accommodation for the different distances is provided by shifting the retinal screen backwards or forwards, and the illuminated arrow can be used as an external object. It is found that if the screen be shifted forward so as to accommodate for objects beyond the arrow, that two blurred images of the arrow obtain. Covering either hole will block either image. But when the eye is accommodated for a more distant object it will be observed that covering the left hole removes the left *retinal* image. If the images be projected, as before, on the lantern screen, the opposite image will of course be removed. The apparent contradiction between Experiments I. and III. is obviously due to the fact that in I. the images are referred to the field of vision, in III. (without the use of further projection on the lantern screen) they are actually viewed as formed on the retina.

EXPERIMENT IV. The near point of accommodation can be conveniently ascertained by noting the least distance at which a single image of a needle can be seen, when using the perforated screen of Scheiner's experiment.

EXPERIMENT V. In Experiment II. note that the thread on which the needle hangs remains clear as a single thread for a certain distance on either side of the needle, but that beyond this distance it gradually bifurcates into a double thread. This singleness of the thread corresponds to the length of the line of accommodation.

CHAPTER LXVIII.

THE RETINA.

1. **The Blood-vessels of the Retina.**—The blood-vessels supplying the retina are distributed to the anterior portion of the retina, the main vessel entering the eyeball at the spot where the optic nerve passes in. These blood-vessels then lie between the vitreous and the sensitive part of the retina, and under certain circumstances they may throw shadows upon this portion of the retina.

EXPERIMENT I. Purkinje's Figures.—Make the subject of the experiment turn one eye inwards, and with a lens concentrate a good light upon the exposed sclerotic, focussing the light so as to make a small but strongly-illuminated area. Let the subject look towards a dark wall. Give the lens a gentle rocking or circular movement. The field will appear to the subject as reddish-yellow, and dark figures will be seen by the subject appearing in the field, which branch and have the character of the retinal blood-vessels, of which they are really the shadows. In the direct line of vision a small area will be seen free from these branching shadows. This is the yellow spot.

EXPERIMENT II. Through a pinhole in a card held close to the eye, look at a brightly and evenly-illuminated surface, as a white cloud or a sheet of thin white paper held in front of a lamp. Give the card an up-and-down movement, and a number of vessels will be seen running horizontally in general. Move the card from side to side, and vertically-running vessels will be apparent. Give the card a circular movement and the general distribution will be visible. Note that in the direct line of vision is a small area in which no vessels are seen, the macula lutea or yellow spot.

EXPERIMENT III. Remove the objective from a microscope, arrange the mirror for a good light, and move the microscope in the same way as the card was moved in Experiment II. The results will be as in that experiment.

In all these experiments the movement of the light or the illuminated field is essential. The retina appreciates these shifting shadows better than if they were continually applied to any fixed point of its surface. Further, a moving object will arouse attention more readily than one of constant position, which tends to be neglected.

2. **The Circulation in the Blood-vessels of the Retina.**—**EXPERIMENT.**—Look through a thick piece of blue glass at a white cloud. Many finely-illuminated points will be seen traversing the field. These

again are followed by slight shadows. Fix the gaze and note that these points move in constant directions. They probably represent small local collapsings of fine capillary blood-vessels, caused by temporary clogging of the red corpuscles. The re-filling of the vessel brings about the shadow following the bright point.

3. **The Blind Spot.**—A certain region of the retina, to the inner side and somewhat below the macula lutea, is insensitive to light, inasmuch as the optic nerve here enters the eyeball, and the layer of the retina which reacts to the stimulus of light is here absent. This insensitive region is spoken of as the optic disc or blind spot.

Experiments showing the nature of the blind spot may be conveniently carried out with the material in Section H. of the **Milton Bradley Pseudoptics** series.

EXPERIMENT I. Using cards H.2, or H.3, close the left eye and fix the gaze of the right eye on the cross. At a distance of about eighteen inches the tree in H.2 or the red disc in H.3 will disappear.

EXPERIMENT II. Arrange the cards H.4 and H.5 at such a distance that when the left eye is closed and the right eye gazes at the cross, the house in H.4 or the red spot in H.5 falls on the blind spot. It will be found that similarly, with the right eye closed and the left eye fixating, the cross, the church, and the yellow disc will be invisible. Having found the proper distance, open both eyes and place the card H.4x close to the nose and in the plane of the septum of the nose. It will be found that when the gaze is directed to the cross the surface of the cards appears uniformly white.

EXPERIMENT III. If a dot and a cross be drawn about four inches apart, the dot being about half-an-inch above the horizontal level of cross, and if then the left eye be closed and right eye gaze at the dot, at the distance of about a foot, the cross will be invisible, as its image falls on the blind spot.

When any image falls upon the blind spot it is invisible. By imagination *we fill in this region* of any image falling upon the retina by sensations similar to those in the neighbouring regions. This is well illustrated in the following experiments.

EXPERIMENT IV. Using the cards H.6, H.7, H.8, and H.9, and ascertaining the distance at which they should be placed, as in Experiment I., notice that when the coloured discs fall upon the blind spot, the place of the discs is taken by a combination of the background on which the discs lie. In H.9 in particular there seems no break in the chequered pattern forming the background to the red disc.

The blind spot may be *mapped out* with ease in the following manner.

EXPERIMENT V. Let the head rest in a fixed position, as by placing the chin in a tin mug, and place a sheet of white paper vertically in front of it at a distance of eighteen inches. Put a dot in the centre of the paper. Close one eye and with the other fixate the dot. Take a thin strip of white card-board and blacken about two millimetres of the end. Move the blackened end over the region of the field of vision corresponding to the blind spot, and note the points where the black area disappears, marking them on the white paper. A sufficient number of these points can be taken, and a curve drawn through them will indicate the margin of the field of the blind spot.

4. The Yellow Spot.—The experiments performed to exhibit the retinal circulation have shown that there is a certain region in the direct line of vision where the retinal blood-vessels are not visible. This region is coloured by a pigment which absorbs the blue and green of the spectrum, and therefore appears of a reddish-yellow colour and is called the yellow spot.

EXPERIMENT. Take a flat-sided bottle containing a fairly strong solution of chrome alum, or use a sheet of purple or violet gelatine. Look with one eye closed through the coloured medium at a bright white surface. A rose-coloured oval spot will appear in the centre of the field. The pigment of the yellow spot absorbs the blue and green, and transmits the rest, and hence the predominant red tinge imparted to the area corresponding to the macula lutea.

5. Acuteness of Vision in different Regions of the Retina.—In order to differentiate similar objects grouped closely together it is necessary that these should subtend an angle of a certain magnitude with respect to the eye. To be more precise, the angle subtended is at the nodal point of the schematic eye, and this angle again is equal to that subtended at the nodal point by the image of the differentiated objects on the retina. In order that objects be differentiated it is apparently necessary that their contiguous margins and the space between should form an image on the retina, which is of certain length. Helmholtz found that a subtended angle of $63.75''$, equivalent to a retinal distance of $.00463$ mm., was necessary for discrimination. As far as this method of investigation is concerned it appears to connect visual acuity with the distribution of the cones.

[**ADVANCED EXPERIMENT.** Set up in a good light the parallel line diagram used in the experiment on chromatic aberration (Experiment III). Or arrange a series of five black wires, separated by their own diameter, against the sky. Walk backward from either of these objects till they can just be no longer discriminated. Calculate the size of the retinal image.

The visual acuity diminishes rapidly on the retina as we recede from the fovea. The diminution is more marked in the vertical than in the horizontal meridian.]

[ADVANCED EXPERIMENT. Place on a card two dots, each 2 mm. in diameter and separated by a distance of 2 mm. Let the gaze be fixed on a mark on a vertical white sheet of paper, and let the card be moved in a horizontal meridian gradually nearer the mark till the two dots can be discriminated. Compare the vertical and horizontal meridia in this respect.]

The acuteness of vision at the fovea is ordinarily tested by noting the distance at which letters, which at a given distance subtend an angle of 5' at the eye, can be read. This method may be applied either to ascertain what error of refraction may exist in the eye, or if this be absent or corrected, what the acuteness of vision in the particular eye is.

EXPERIMENT III. Using Snellen's or Jaeger's test types, ascertain whether the letters can be correctly named at the normal distance in a good light. If this distance can be exceeded or if it cannot be reached an expression for the condition of the acuteness of vision may be written as follows :

$$V = \frac{d}{D}$$

where d = distance of person from the types and D = number of smallest type which a person can read at that distance.

6. **Mechanical Stimulation of the Retina.** — **Phosphenes.** — The retina can be stimulated by pressure on the sclerotic. An image will be produced which is referred to the opposite portion of the field of vision.

EXPERIMENT I. Close one eye and turn it as far as possible towards the nose. Press with a pencil point on the sclerotic, through the eyelid, at the edge of the orbit on the outer side. Note the circle of light which appears on the nasal side. The retina is stimulated just beneath the pressure and the image is referred to the nasal side of the field of vision.

7. **The apparent Inversion of Shadows thrown upon the Retina.**—If a beam of light falling upon the retina be intercepted by some object close to the cornea, an erect shadow of the said object will be thrown upon the retina. This, however, will be projected into the field of vision as an inverted image.

EXPERIMENT. The Experiment No. 6, Section I. in Milton Bradley Pseudoptics, illustrates the nature of retinal shadows well.

8. **The Perception of Colour in the Peripheral Portion of the Retina.** —The sensibility of the retina for colour varies in different zones of the

retina, and for different colours. Blue and yellow can be recognised at a greater distance from the fovea than red and green. Still more peripherally all colours appear as black, grey, or white.

EXPERIMENT I. Milton Bradley Pseudoptics, Section H, Experiment No. 1, conveniently illustrates the variation in the sensibility of the retina for colour.

EXPERIMENT II. If a perimeter or campimeter be used the boundaries of the field for the different colours can be defined. (See use of perimeter.)

9. **The Perception of Light in different Regions of the Retina.**—A faint light is often more easily seen when its image does not fall on the fovea, but a few degrees away from this. The recognition of a light at sea on a dark night is often facilitated by directing the gaze some ten degrees to the right or left of the supposed luminous object. Faint stars again may be seen more readily if not directly gazed at.

10. **After-images.**—After-images may be of two kinds, those which reproduce the original body in all its brightness, those that are the reverse in brightness to the original body. The first are called **positive** after-images, the second are **negative** after-images. Positive after-images may be either of similar colour to the original body or complementary in colour, negative after-images are always complementary. They are due to certain changes taking place in the retina and are best observed in the early morning after waking.

EXPERIMENT I. Close the eyes for two minutes to rest them and then for the briefest possible interval look at some bright source of light as the lamp or the window, closing the eyes again. A bright positive after-image of the source of light will be seen.

EXPERIMENT II. Look at the incandescent filament through a piece of red glass, as in Experiment I. The positive after-image will appear red. Again look at the filament but for a prolonged period of about half a minute. On closing the eyes the after-image will appear bright but greenish in colour.

By an alteration of light and dark backgrounds the after-image may be changed from negative to positive.

EXPERIMENT III. Look at an incandescent lamp for half a minute and so get a well marked after-image. If the eyes be directed to a white surface the after-image will be negative, if to a dark surface it will appear positive.

[**ADVANCED EXPERIMENT.** Note the colour of the after-images in Experiment III., and the gradual change in colour which they show. If the after-images tend to fade blink the eyes several times rapidly and they will become more marked. Notice especially the effect of

blinking on the negative after image seen on the white surface. It will become during the shutting of the eyes converted into a positive after-image.]



FIG. 215.—Disc for the experiment on after-images of motion.

[ADVANCED EXPERIMENT. Look at an incandescent lamp with the right eye, the left eye being closed. After the lapse of half a minute, shut the right eye and look with the left at a dot on a white sheet of paper, as far as possible without blinking. After a time the field will gradually darken and a positive after-image will be seen. This is really the after-image seen with the right eye, which is not visible till a certain amount of retinal insensibility has occurred in the left eye.]

[ADVANCED EXPERIMENT. After-images of motion may be shown by gazing at the disc in Fig. 215 slowly rotated and then shifting the gaze to some uniformly mottled surface.]

CHAPTER LXIX.

SENSATIONS OF LIGHT AND COLOUR.

MANY theories have been advanced to explain the phenomena connected with colour vision. The most important of these theories are those connected with the names of Young-Helmholtz and Hering.

The theories are all concerned in referring the multiplicity of colour

sensations to fusion of certain simpler sensations, which are described as primary colour sensations. In the Young-Helmholtz theory the primary sensations are those corresponding to red, green, and blue-violet; in the Hering theory they are grouped in pairs, which are the red and green sensations, the yellow and blue sensations, and the white and black sensations. It is necessary to assume the existence of certain photo-chemical substances in the retina, which can be acted upon by the light of the primary colours. The light at the ends of the spectrum would, in accordance with the Young-Helmholtz theory, act upon either the red visual substance or the violet visual substance, in the intermediate part of the spectrum upon all three visual substances to different extents. If all are affected more or less equally, the compound sensation of white is produced.

In the Hering theory there would also be assumed to exist three primary visual substances, but according to the chemical changes in any single substance, whether of the constructive or destructive variety, so a sensation corresponding to one of the complementary colours of the different pairs would be brought about.

A certain classification of colours is necessary. They may be conveniently described as varying in hue, tint, or shade. The hue of a colour is its **colour tone**, corresponding to its wave length. The **tint** of a colour depends upon its purity, or whether it is admixed with white—in other words, depends upon its **saturation**. The **shade** of a colour is an expression of its brightness or **intensity**, or, what comes to much the same thing, the degree to which it is admixed with black.

1. **Colour Tone.**—In reviewing the changes of hue that are appreciable in examining the spectrum, it is to be noticed that the changes do not occur at any regular intervals corresponding to wave lengths. Changes of colour tone are most easily appreciated in the yellow, green, and blue green. At the red end and violet ends there appears to be little or no change of hue.

The variations in saturation or tint can be seen by using the red and white discs of a colour mixed in varying proportions and noting the corresponding sensations produced.

2. **Intensity.**—Variations in intensity cause changes in the quality of colours. At their maximum brightness colours tend to give the sensation of white, though they never completely do this. The yellow will the most easily; the blue and violet approach close to it. The red is most distant in producing the sensation of white.

EXPERIMENT I. Take a small square of red paper and a similar piece of blue paper which in a light of moderate brightness appear of approximately equal intensity. Carry these to an almost dark room

and note the dulness or even blackness of the red whilst the blue may still appear bright.

3. The Fusion of Distinct Sensations of Black and White. Flicker.—This fusion depends upon the persistence of the positive after-images each separate stimulus brings about. If separate stimuli follow each other sufficiently rapidly a blending of the different sensations occurs, as is well exemplified in the presentation of the series of rapidly succeeding views in the cinematograph. The phenomena upon which this depends can be shown in a revolving disc divided into rings of sectors of white and black, increasing in number from the centre to the circumference. Such a disc is included in the Petzold series.

EXPERIMENT I. Rotate a disc such as (Fig. 216) slowly, and note that at a certain rate the peripheral ring appears as a uniform grey, a flickering sensation is produced on the neighbouring rings, but the central rings show an alternation of white and black. Increase the rate and note that these can also be caused to blend.

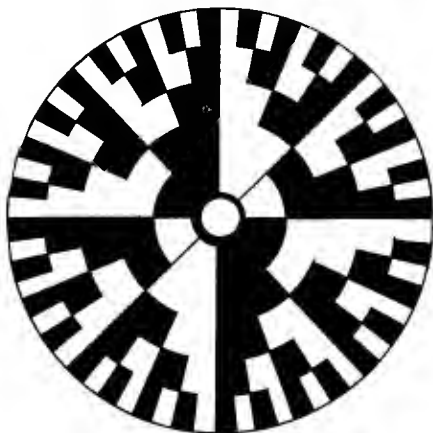

FIG. 216.

In general it may be stated that when fusion in any way occurs the resulting sensation of grey is the same as if the light reflected intermittently were replaced by the same quantity of light continuously reflected, in other words, as if a uniform grey of a certain shade were substituted for the series of sectors; moreover, if the rate at which the sectors are successively presented to the retina be increased above that necessary for fusion, the intensity of the resulting sensation is not altered. (Talbot-Plateau Law).

The rate necessary for the flickering sensation to pass into complete fusion depends upon the intensity of the light.

[ADVANCED EXPERIMENT. With a metronome, note the rate of revolution necessary to produce complete fusion in the outer ring. Darken the room and observe whether the rate be altered. It will be found that with diminished light a slower rate of revolution brings about fusion. The converse is true up to a certain limit.

The point at which flicker passes into fusion has been used as a means of determining the condition of persistence of visual sensations. It is to be noted that the flicker may be coarse or of a fine tremulous character. The transition of this fine flicker into fusion should be taken as the limiting sensation.

The excitability of any portion of the retina is influenced by the stimulation of that portion of the retina (temporal induction) and changes are simultaneously induced in neighbouring regions of the retina (spatial induction). These factors may be of very considerable influence in determining the point at which flicker passes into fusion. A 'physiological' state is brought about by a certain 'physical' stimulus, and thereby the effect of the stimulus may be increased or diminished. If then a succession of stimuli of say blue and black be presented to the retina at a certain rate flicker will pass into fusion. But if the blue be intensified by being placed on a black background this rate will no longer be sufficient. This may be shown in the following manner.]

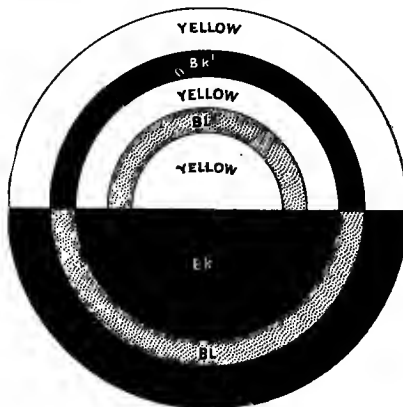

FIG. 217.

[ADVANCED EXPERIMENT. Take a disc like that shown in Fig. 217 with black and blue semi-circular rings, and yellow and black back-

grounds On rotating this disc it will be observed that the flicker persists much longer in the outer blue and black ring than in the inner blue and black ring.

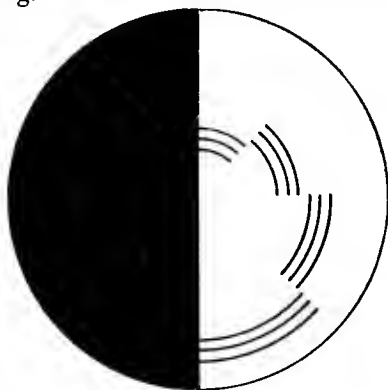

FIG. 218.

Fechner showed that certain colour effects may be produced by slow rotation of discs which consist of black sectors of increasing size on a white ground. They may also be seen in a disc showing black circular lines of different circumferences on a white semicircular area, the other half of the disc being black. Such a disc is shown in Fig. 218. It has been shown that a bright object on a dark background appears, when suddenly exposed, to be surrounded with a red border lasting a fraction of a second. If the illumination be brighter a blue green effect is visible. These facts in part explain the appearance of colours shown when the discs below are rotated.]

4. The Fusion of Colour Sensations.—Several methods have been devised with the object of enabling us to fuse separate colour sensations. These depend either upon separate colours forming images on the retina in such rapid succession as to be inseparable, or else upon separate colours forming images in the same portion of the retina so that the sensations are super imposed.

The first method is generally carried out by means of the separate colours being arranged as sectors in a circle, which is rapidly revolved about its centre, the instrument adapted for the purpose being known as a **colour-mixer**. Discs of different colours, such as the Wundt series, are obtainable, and each disc has a radial slit at one point so that these can be arranged upon a common centre and a circle may be made up of sectors of various discs. It is desirable to have discs of two sizes, one about ten inches across, the other four or five inches. It is to be remembered that these discs are not coloured with pure colours of the

spectrum, and the results of their mixture yields various colours which are largely mixed with grey.

EXPERIMENT I. Take two large discs of red and green and two small of black and yellow. Adjust the proportion of the red and green so that rapid revolution produces a yellow. This will be dark in shade and can be matched by the inner discs of yellow and black.

EXPERIMENT II. Take large discs of green and violet and small discs of blue and black. With the large discs a blue can be obtained and matched with the smaller discs.

EXPERIMENT III. Take three large discs of red, green, and violet. To bring about a good result the red should correspond to the red in the spectrum at wave-length 6300, the green to wave-length 5150, and the blue to wave-length 4700. Arrange these so that red constitutes about 118° , green about 146° , and blue about 96° . Arrange also two smaller discs of white and black. As the result of revolution the larger discs will give a grey, which can be matched by about 285° black and 75° degrees white of the smaller discs.

EXPERIMENT IV. Using the three discs of Experiment III., work gradually through the whole spectrum, using different sized sectors of each for the different regions of the spectrum. The sizes of these sectors will roughly correspond to the different degrees in which the three primary colour sensations according to the Helmholtz theory are evoked.

The best method of fusing the colours sensations is to superimpose the various colours of the spectrum by projection of the same on a white screen.¹ By means of lenses the spectrum can be recomposed as white light. By introducing shutters eliminating certain portions of the spectrum the result of fusion of the remaining colours can be examined.

5. **Complementary Colours.**—For every colour in any part of the spectrum there is a colour in another part of the spectrum which, when mixed with it, will yield a white or grey. Such colours are said to be complementary.

EXPERIMENT I. Take from the series of colour discs one of an orange colour. If no disc can be found which in any proportion with the orange disc will give a white or grey, take the blue and green discs and adjust all three so that a grey is obtainable. (This should be estimated by smaller discs of black and white). A certain proportion will exist between the blue and the green. If now the whole circle be

¹See Abney, *Colour Vision*, p. 18 *et seq.*

divided up into blue and green in this proportion, revolution will give the hue of the colour complementary to the orange originally selected.

It will be found by such experiments as this that orange is complementary to greenish-blue, red to bluish-green, yellow to blue, yellowish-green to violet, and green to purple.

EXPERIMENT II. If a coloured object be viewed on a white surface it may provoke a negative after-image in colour complementary to that of the original object.

In illustration of this perform the experiments Nos. III. and IV. of Section E in the Milton Bradley Pseudoptics series.

6. Contrast.—Besides the effect which different colours produce when presented simultaneously, or practically simultaneously, to the retina, as in colour-mixing, other effects also will come about when different colours are presented successively and comparatively slowly to the same portion of the retina, or again, when different colours are presented simultaneously to adjacent areas of the retina.

In the first of these two cases we have the conditions of **Successive Contrast**, in the second we have **Simultaneous Contrast**.

The second experiment in the section on Complementary Colours affords illustration of Successive Contrast. In general the nature of successive contrast may be shown as follows.

EXPERIMENT I. Take a number of small squares of various colours each about 1 cm. in size. Arrange also a series of fields of different colours, as well as one of white; these may be squares of 1 or 2 decimetre side. Taking a small red square, place this in the centre of the large white square and in a good light gaze at it for two or three minutes. Blow the small object away and continue the gaze. An after-image of the object will be obtained of a colour complementary to that of the original. Substitute for the large white square squares of different colour and perform the experiment again. It will be found that the after-image varies in colour according to the ground on which it is viewed. If red be the colour of the original small square, the after-image on white will be green or bluish-green. If projected on violet the after-image will be blue and if on orange a dull brown.

EXPERIMENT II. By projection successive contrast may be easily demonstrated as follows. Two lantern slide glass plates are taken, and on one is marked out, in centre of plate, two concentric circles of about 1.5 and 3 cm. radius, enclosed by black lines of just perceptible thickness and having a central dot of about the same 2 or 3 mm. diameter. On the second glass plate are fixed rings of coloured gelatine of similar size to the two circular rings, the colours

chosen being preferably complementary. The two slides are projected simultaneously and the rings are gazed at (the central dot being used as fixation point), for half a minute. The slide with the coloured rings is then suddenly removed, the gaze remaining on the dot, when the two rings will be seen in colours complementary to the original colours.

Simultaneous contrast may be shown in the following shadow and mirror experiments.

[ADVANCED EXPERIMENT. Arrange two sources of light about six inches apart, and allow each of these to throw a shadow of some opaque object upon a screen held about a yard from the source of light. (8 candle-power and 16 candle-power electric incandescent lamps answer very well for the two sources of light.) Interpose a coloured glass plate in front of the weaker light. The shadow corresponding to this will be the same colour as the plate, the other shadow will become coloured complementarily. Observe the variation in intensity of colour according to the proximity of the two shadows. If the object be moved away from the screen the two shadows will separate and the colours will be dull, if the object approach the screen closely the shadows will almost touch and the colours will be extremely vivid.]

[ADVANCED EXPERIMENT. Arrange a mirror horizontally, so as to reflect light from a white surface, *e.g.* a white lamp shade. Place a coloured glass plate over the mirror. Interpose an opaque object, a pencil or the finger, in the course of the white light incident on the mirror. Observe that two reflected images of this are seen, one from the surface of the coloured glass and of the same colour as the glass, the other reflected from the surface of the mirror and complementary in colour. Gently tilt the coloured glass so as to separate the images. It will be found that they are most brilliantly coloured when slightly overlapping.]

EXPERIMENT III. Place the dark grey papers of Experiments III. and IV., Section G, of the Milton Bradley Pseudoptics on the different coloured fields and cover with tissue paper. Observe the contrast colour that appears in the grey paper.

EXPERIMENT IV. Arrange on the colour-mixer the discs of Experiment V., Section G, of the Milton Bradley Pseudoptics. On rotating these, the black and white rings will assume a colour in contrast with that of the general field.

[ADVANCED EXPERIMENT. The Experiments I. and II., of Section G, Milton Bradley Pseudoptics, illustrate the effects of contrast in black and white alone.]

The above experiments on Complementary Colour and Contrast depend upon variations in excitability in the retinal area involved or in adjacent retinal areas. The change in excitability that occurs in any retinal area when affected by incident light is spoken of as caused by **temporal induction**, and the change that is brought about in adjacent areas as resulting from **spatial induction**. Successive contrast depends upon temporal induction, simultaneous contrast upon spatial induction. The phenomena connected with the formation of after-images are examples mainly of temporal induction.

With regard to the complementary colour of after-images, this is thought by some to be simply the result of fatigue. Others regard the phenomena as due to initiation of processes, the converse of those brought about by the original stimulus. Hering's theory of colour vision involves an explanation of these processes in accordance with the latter view.

In this connection it will not be out of place to refer to a phenomenon known as **Irradiation**.

EXPERIMENT V. Let a black square be inscribed in a white square of three times the size, and conversely, let a white square be inscribed in a black square of three times the size. The side of the inner square will be equal and should be about a centimetre long. If the two figures be placed side by side, the inner white square will appear larger than the inner black square. The material for this experiment on a larger scale is also provided in the Milton Bradley Pseudoptics, Section C, Experiment IV. The explanation of this may be due to the dispersive power of the lens, as the appearance is more conspicuous with a large pupil, or it may be due to the chemical processes of a certain kind (katabolic) in the retina tending to encroach on adjacent fields of the retina, the opposite processes (anabolic) apparently not having that tendency.

EXPERIMENT VI. A line passing through the adjacent edges of two rows of black squares, arranged so as to overlap appears oblique. See Milton Bradley Pseudoptics, Section B, Experiment V.

7. Colour Blindness.—The inability to distinguish different hues of colours constitutes the condition of colour blindness. It may vary much as regards the failure shown. A person may be red blind and then only appreciates the colour of red objects as far as they show other constituents of white light. Such a person, according to the Helmholtz theory of colour vision, would be entirely lacking in the production of the red sensation. Or a person may lack the green sensation and be green blind, and very rarely violet blindness may exist.

If a red blind person be examined as to his sensations along the range of the spectrum, he sees nothing at the extreme red end of the spectrum at all. A glimmer of what he calls dark green is seen in the position of the red lithium line, and this green gradually becomes more conspicuous to him through the yellow to the proper green. Passing to the blue green he says the colour is grey, being similar to his idea of white admixed with a certain amount of black. Passing further to the blue end he recognises the blue and speaks of the violet as dark blue. Similarly, a green blind person will recognise a grey in the middle of the spectrum, but rather more in the green than the locality thus named by the red blind.

Colour blindness can be conveniently tested by the use of a series of coloured wools of great variety of hue and tint. Such a set of wools are spoken of as Holmgren's wools. The method, however, is not a safe test.

EXPERIMENT. Spread out the wools on white blotting-paper in a good light. Avoid mentioning the names of the colours of any of these wools, but pick out a whitish green, and request the subject to collect all those wools which approximate in hue or tint to the colour presented.

If any errors are made, proceed to test whether he is red blind, green blind, or violet blind. Give him a skein of a magenta hue. If he is red blind he will pick out blue and violet; if green blind he will confuse green and grey.

The matching of colours may be also carried out by rotating the various cards of the colour-mixer, and thus matches of any colour under examination can be obtained. The same result can be obtained by projecting various portions of the spectrum as mentioned in colour mixing.

CHAPTER LXX.

BINOCULAR VISION.

THE images formed on the two retinæ of an external object amongst its surroundings will not be identical. The lack of identity enables an observer to form a judgment as to its position in space. Such a judgment is more easily formed when the object is comparatively near than when far off, as in this latter case the images are approximately similar. Though the images for objects at a certain distance are not identical, it is necessary that they should be thrown on certain corresponding parts of the retina in order that a single sensation should result.

In order that a single image then should result, it is necessary that

various movements of the eyes should occur, so that the two images should fall on corresponding points.

With reference to the movements of the eyes, it is customary to regard them as taking place about three axes: (*a*) the *sagittal* axis, corresponding nearly to the line of sight; (*b*) the *frontal* axis, extending from right to left in each eye; and (*c*) the *vertical* axis. These axes are regarded as intersecting at one point the *centre of rotation* of the eye. With the head in fixed position the extent of space in which objects can be seen by allowing the maximum of eye movement is called the **Field of Regard**. If the head and body are erect and the eyes are directed towards the distant horizon, the position assumed is spoken of as the **Primary Position**. The point upon which the eyes are fixed is called the **Principal Point of Regard**. A position which the eyes may take up which does not conform to the requirements of the Primary Position is called a **Secondary Position**. If an observer shift his gaze from the principal point of regard to some other point in the field of regard, he may pass directly to this new position, or may pass over a varied number of different points in the field of regard before reaching this final position. The amount of rotation about the different axes of the eye finally involved in adopting this new position will be the same whether the eye pass to it directly or by a number of varied intermediate positions. In other words, only one position is possible when the gaze is shifted to this second point. This is called Donders' law. An extension of the rule is seen in Listing's law, which lays down that in moving from the primary position there is no rotation at all upon the sagittal axis, but merely upon the horizontal and vertical axes.

1. Binocular Direction.—In judging of the position of near objects, they are referred not to either eye separately, but to an ideal eye situated midway between the two actual eyes, the so-called Cyclopean eye of Hering. A line drawn through the object to the centre of such an eye is the Binocular Line of Regard.

EXPERIMENT. Make a pinhole in a sheet of paper, and starting with the hole well to the right of the right eye, draw the paper across the eye horizontally, so that the pinhole will pass across each eye successively. First one and then a second image of the pinhole will be seen as it passes over each eye, but in either case the hole will be referred to the median plane or the Cyclopean eye, and will seem like a succession of two holes over this eye.

2. Single and Double Images.—If the two eyes be directed towards an object about two feet off, and a finger be held up in the binocular

line of regard about a foot from the eyes, a double image of the finger will be seen. In this case the images of the finger will fall upon non-corresponding parts of the retina, and hence the images will not combine to form a single sensation.

EXPERIMENT I. Place a rod vertically about two feet from the eyes. Adjust the vision for a clear image of the rod. Then hold up a finger in the binocular line of regard about twelve inches from the eyes. A double image of the fingers will be seen. Close the left eye, the right image will disappear. Then accommodate for the finger, and a double image of the rod will be seen. Close either eye, and the image on the same side will disappear.

This experiment may also be performed with the material in the Milton Bradley Pseudoptics, Section I., Experiment I.

The double images seen, the above experiment may be crossed or uncrossed. If crossed they are spoken of as heteronymous images, if uncrossed, as homonymous images.

In general, if the optic axes of the two eyes converge towards a certain point, and a circle be described passing through this point and the two centres of rotation of the eyes, then an object outside the circle will produce homonymous images, and an object inside the circle, heteronymous images. With a definite point of regard, then, it will be found that if a circle be described through this point as above, objects lying on this circle will be seen single. Such a circle is called a horopteric circle, and the complete surface (intersected as above by a horizontal plane, forming a circle) is referred to as a horopter.

Double images of single lines may be shown in performing the Experiments II. and III., Section I., of the Milton Bradley Pseudoptics.

When double images lie, not symmetrically with regard to the line of regard, but both to one side of that line, that nearer the line of regard is the more distinct, and the other is hardly discernible.

[**ADVANCED EXPERIMENT.** Fix the eyes on some remote object, and hold a pencil about six inches from the right eye and about two inches to the right of a line passing from that eye to the remote object. The image falling upon the right retina will alone be appreciated. Close the right eye, and the second image will also be observed.]

In general the image falling upon the nasal side of one retina will dominate over that falling on the temporal side of the other retina.]

3. Binocular Fusion of Dissimilar Images.—If two partially dissimilar images, or at any rate not absolutely identical images, fall upon

corresponding points of the two retinae, the sensations corresponding to a single image result.

EXPERIMENT I. Place on a stereoscopic slide, or on a sheet of cardboard, red and green postage stamps at a distance from each other equal to the interocular distance, and similarly arranged. Observe these in the stereoscope, and the sensation of a single image of a black or brown postage stamp will result.

EXPERIMENT II. Perform the experiment in the Milton Bradley Pseudoptics, Section K, Experiment III. The fusion of the two retinal images gives the impression that one is looking through a round hole in the hand.

4. Binocular Perception of Relief.—The perception of relief which enables a judgment as to solidity to be formed depends upon the fact that the two pictures presented to the retinae are not identical. The amount of variation in the pictures will depend upon the interocular distance and the propinquity of the objects. The first being constant, it follows that a judgment as to solidity is more easily formed in the case of near objects than distant objects. Similarly, a judgment as to the relative distances of an object from the observer depends upon the difference in position of an object with respect to surrounding objects which exists in the two views presented to the two eyes.

The difficulty in forming a judgment as to the precise position in space of an object when viewed with only one eye may be shown in the following experiment.

EXPERIMENT I. Stick a knife into the wall, and balance on the handle a cork. The height from the ground should be about five or six feet. Close the left eye, and, starting at about ten feet from the wall with the right hand extended forward, walk rapidly to the cork, and by a sweep of the hand attempt to remove the cork. A lack of success will frequently attend the effort.

It is seen from this experiment that it is difficult to locate any object precisely in space when a single ocular view is alone obtained.

On the other hand, if perfectly flat pictures be taken differing from each other to the same degree as actual pictures presented to the two eyes would differ, and if such flat pictures be combined by some form of stereoscope, or by crossing the eyes, the resulting sensations will correspond to a single picture on which the different objects are differently projected into the space embraced by the picture, in which the quality of *depth* is added to the flatness shown by each picture separately.

These effects can perhaps best be shown by examining the Martius-Matzdorff¹ series of diagrams with a stereoscope.

Visual Illusions.—The study of Visual Illusions is somewhat beyond the scope of the present work, but the student may advantageously perform various of the experiments on the Milton Bradley Pseudoptics, which illustrate many of these illusions. The Sections A, B, C, D, and J are specially recommended in this connection.

CHAPTER LXXI.

THE OPTICAL DEFECTS OF THE EYE.

1. **Spherical Aberration.**—This is probably of little consequence in the eye, as the action of the iris eliminates it largely.

2. **Chromatic Aberration.**—Rays of coloured light are refracted differently according to their position in the spectrum. Those of shorter wave length, as the violet and blue, come to a shorter focus than do those of longer wave length, as the red.

EXPERIMENT I. Look through the upper part of a window towards the sky. Pass a card before the eye with the edge parallel to the upper side of the window frame. If the card be passed from below upwards, when it has covered about half the pupil the frame will be seen to have a border of blue. If the card be passed from above downwards, when it covers half the pupil the edge of the frame will be seen to have a reddish-yellow fringe. In the first case the less refracted red constituents of the margin of the white light are cut off by the card, in the second case the more refracted blue rays.

EXPERIMENT II. Look at the incandescent filament of an electric lamp. Pass a card across the pupil with the edge parallel to the filament. When the edge of the card is almost covering the filament, the filament is seen to have a red fringe on the side nearer the card, and a blue fringe on that more remote.

3. **Astigmatism.**—It is frequently the case that the curvature of the cornea, or lens, in the vertical meridian is greater than that in the horizontal meridian. Therefore, accommodation for a horizontal bar at a certain distance means under-accommodation for a vertical bar at the same distance. Persons who have such a spoon-shaped cornea are said to suffer from regular astigmatism.

The cornea, or lens, may have irregular curvatures in various meridians, resulting in irregular astigmatism.

¹The diagrams can be obtained from Winckelmann und Söhne, Berlin; Petzoldt, Leipzig; or from Messrs. Baird & Tatlock, Cross Street, Hatton Garden, London. From the latter firm can be obtained any of the instruments mentioned above or the Milton Bradley *Pseudoptics* Series.

EXPERIMENT I. Adopting the method of ascertaining the near point of accommodation in Scheiner's experiment (Experiment IV., page 239), observe the near points of accommodation for a pin held vertically and one held horizontally. Note if the distances are identical.

EXPERIMENT II. Draw a rayed figure as follows: First, draw two lines intersecting in the centre at right angles, and each about 5 cm. long. Bisect each right angle by two other lines intersecting at the same point, and each of these smaller angles bisect further by four other lines. Bring this rayed figure to the near point of accommodation. Observe which of the lines can be distinctly seen, and which are blurred. It will generally be found that the horizontal and those adjacent will be clearly seen, when no effort will bring about definition of the vertical.

EXPERIMENT III. Using Kühne's artificial eye, place in front of the cornea the special glass trough (filled with water) designed for exhibiting the nature of astigmatism. This has a plane surface posteriorly. The anterior surface, however, is that of a cylinder, curved in horizontal meridia but not in vertical meridia. Substitute for the arrow used in earlier experiments as a source of light a stencilled cross, each bar being about 5 cm. long and $\frac{1}{2}$ cm. wide. Before introducing the astigmatic lens, ascertain the position of the retinal screen necessary for definition of the luminous object. Then place the lens in position. The image will become changed. It will be found that the upper and lower edges of the horizontal bar and the ends of the vertical bar are still distinct, but otherwise definition of the vertical bar is absent. In order to obtain definition of the vertical bar it will be necessary to move the screen much closer, when a reversed effect will be seen—viz., definition of the vertical bar, its end, however, blurred; the end of the horizontal bar clear, but its edges altogether undefined. At no intermediate position between the two foci can a clear image of the cross be obtained, and it will be necessary in order to compensate for the presence of this lens, convex in horizontal meridia, to introduce a second lens, plane on one surface, and concave in horizontal meridia. This indicates the method of correction of the defect in the human eye.

4. **Errors of Refraction.**¹—In this division of the optical defects are included the conditions of **Myopia** or short-sight, **Hypermetropia** or long-sight, **Presbyopia** or the sight of old people.

The normal eye in which the far point of accommodation is practically infinity and the near point 20 cm. (8 ins.), is spoken of as **emmetropic**.

Presbyopia.—As a result of advancing age the power of accommoda-

¹ Properly speaking, *astigmatism* should be included in this section. We have thought it best, however, to consider it in a separate section.

tion for near objects may become diminished. Parallel rays are still focussed on the retina, but the ciliary muscle is unable to bring about sufficiently increased curvature of the crystalline lens to accommodate for objects as near as eight inches. It may here be mentioned that in the normal eye continuous exercise of the full power of accommodation rapidly produces fatigue. It is impossible without fatigue to use more than a half to two-thirds of the full accommodation for any protracted period. The normal-sighted person instinctively avoids placing near objects, *e.g.* a book, closer to the eye than about sixteen inches. Similarly a presbyopic person whose near point is, say, ten inches, will hold a book at about twenty inches distance. Unless the illumination be extremely good the small size of the retinal image causes some difficulty to occur in reading. This, however, may easily be corrected by assisting the crystalline lens through using convex glasses, the degree of convexity corresponding to the extent of failure of accommodating power. These are, of course, only necessary when looking at objects close to the eye. It may be mentioned here that the distance of the near point gradually increases from infancy to old age. According to Landolt it is about 3 inches at 10 years of age, 4 inches at 20 years, $5\frac{1}{2}$ inches at 30 years, almost 9 inches at 40 years, 16 inches at 50 years, 40 inches at 60 years, at 70 years about 13 feet, and at 75 there is practically no near point, in other words the power of accommodation is generally lost.

Ametropia.—This is a term applied to all conditions of the eye in which the retina does not lie at the focus for parallel rays. The retina may lie in front of this focus when we have the condition of *hypermetropia*, or behind when *myopia* is the result, or the focus may be a linear one for any distant luminous point when we have the condition of *astigmatism*.

Hypermetropia.—In this condition the antero-posterior axis of the eye is generally too short. By some effort of accommodation, distant objects may form a clear image on the retina, but the individual suffering from this optical defect does not possess sufficient power of accommodation to focus clearly near objects. Though the emmetropic condition with much facility of accommodation is acquired at about the age of eight years, before this stage is reached the eye is naturally hypermetropic. A young child with marked hypermetropia and deficient power of accommodation will in viewing near objects (*e.g.* reading), make every effort with both eyes to accommodate for such objects. Included in this effort would be an exaggerated action of the muscles producing convergence of the optic axes of the eyes, leading to squint, but such squint will frequently be removed on correcting the optical defect.

EXPERIMENT. Using Kühne's artificial eye, place the retinal screen in the position necessary to obtain a clear image of the external luminous arrow. In this position of the retina the condition of the eye may be regarded as emmetropic. Now move the screen about an inch nearer the corneal surface. The image at once becomes blurred. This represents the condition of the hypermetropic eye. Now place in front of the cornea a very weak convex lens. The image will become much clearer, and with little difficulty a lens of sufficient converging power may be chosen which will exactly correct the defect.

Myopia.—This defect is usually congenital, the result of the antero-posterior diameter of the eye being too long. As a result parallel rays are brought to a focus in front of the retina, and the eye cannot form a clear image of an object beyond a certain distance (far point of accommodation). The most common cause of acquired myopia in children is the reading of books with insufficient light. The child brings the book close to the eye to get a sufficiently large image of the words and this finally leads to a myopic state.

EXPERIMENT. Using again Kühne's artificial eye, which, as in the last experiment, is first adjusted as the emmetropic eye, shift the retinal screen about an inch away from the cornea. The arrow now becomes blurred and the eye resembles the myopic eye. Place in front of the cornea a concave lens. The image will become much clearer if the degree of concavity corresponds to that of the defect. It is necessary in this case to use a lens of dispersive power in order that the image may be thrown back on to the retina.

CHAPTER LXXII. (*Advanced*).

THE OPTICAL DEFECTS OF THE EYE.

1. **Myopia and Hypermetropia.**—The condition of the refractive media of the eye when either hypermetropia or myopia are present are conveniently tested by what is known as the **shadow test**. If one take a concave mirror (such as that of an ophthalmoscope used for the indirect method), and reflects the light of a lamp at the side of the subject into the pupil of the eye, on looking through the aperture in the mirror the back of the eye is seen to be partially illuminated. If the subject be emmetropic the amount of illumination is small, and on tilting the mirror a little to the right or left a scarcely perceptible movement of the light area may be seen in the opposite direction of the tilt. The image of the lamp formed by the concave

mirror is the direct source of illumination of the subject's eye, and this image moves to the right when the mirror is tilted to the right, and in accordance with the inversion of the image on the retina the illuminated area will seem to pass to the left. The general impression that one obtains of the result of tilting the mirror on the emmetropic eye is that the illumination suddenly disappears. With the hypermetropic eye the illuminated area is more distinct, as a large part of it can now be seen, and the passing of this area to the right or left inversely to the tilting of the mirror to the left or right is clearly visible. In the case of myopia the observer must be beyond the far point of the eye and then will see an inverted image of the illuminate area. As the result the apparent illuminated area will be an inversion of the actual area. When therefore the mirror is tilted and the image of the lamp passes across from right to left, the apparent movement will be from left to right, so that the movement of the light on the retina appears to be the same as the tilt of mirror. A small amount of myopia cannot be made out by this method.

EXPERIMENT. If subjects possessing the defects of myopia and hypermetropia cannot be obtained, using the ophthalmoscopic mirror as directed above, observe the movement of the light on the retinal screen in Kühne's artificial eye adapted for these defects. Compare the actual movement of the light on the screen with the apparent movement when observing in front of the eye as above.

2. Imperfections of the Refracting Media, Entoptic Phenomena.—(a) Certain bright, cloudy appearances may be seen, which disappear after blinking the eyelids. Wavy lines or speckled patches may appear after rubbing the eyes. These are all due to the condition of the corneal surface, and have been more properly called 'pseudentoptic' phenomena.

(b) Dark specks or irregularly stellate figures may be seen, depending upon imperfections in the lens or its capsule.

(c) *Muscae Volitantes*. These appear as moniliform threads, clusters of bright or dark circles, and are referable to imperfections in the vitreous.

EXPERIMENT. Place a card which is pierced by a pinhole a little more than a centimetre from the eye (*i.e.* in the position of the principal anterior focus of the 'reduced' eye). Look at an evenly but brightly illuminated surface beyond, as a sheet of thin white paper held in front of a lamp. The rays of light falling on the retina are now approximately parallel, and any shadows that form in consequence of imperfections in the refracting media are rendered more distinct. Notice any of such shadows that may be received by blinking, due to imperfections in the cornea or any comparatively fixed figure due to imperfections in the crystalline lens. These may be practically absent.

No difficulty will be experienced in recognising 'muscae volitantes.' These will appear as small particles or threads which appear to move away rapidly when the gaze is directed at them. When the gaze is fixed, as by a mark on the white paper, they are still seen to move slowly downwards. This implies that actually their shadows are moving slowly upwards, and that the objects themselves are similarly slowly ascending in the vitreous.

If, whilst gazing at some distinct cluster of muscae volitantes, the eye move upwards, the cluster will appear to move upwards too. This actually means that the shadow of the cluster is moving downwards on the retina. If the card be moved downwards the same result, as far as the shadows are concerned, will occur. From this it may be inferred that the objects producing the shadow are behind the nodal point (situated in the crystalline lens), and therefore, if the movement of shadow be appreciable, on the vitreous.

Objects in front of the nodal point, such as impurities on the cornea, would appear to move upwards when the gaze is directed downwards, and conversely.

CHAPTER LXXIII.

THE INSTRUMENTS USED IN THE CLINICAL INVESTIGATION OF THE EYE.

The Measurement of the Field of Vision.— If the eye be fixedly directed to some particular point it is possible to see objects at some distance from this point. The area in which objects can be seen with the eye thus fixated is spoken of as the *field of vision*. With the head fixed and the eye allowed to move as far as possible in any direction a much larger area can be viewed. This area is spoken of as the *field of regard*.

Though fairly satisfactory results can be obtained by using a comparatively simple form of apparatus called a campimeter, it is customary to employ an instrument called a **perimeter** to obtain accurate details of the extent of the field of vision.

The perimeter (see Fig. 219), consists of a quadrant upon which a white spot can be moved, and this quadrant can be revolved about a line continuous with the optic axis. At *K* is the chin rest, double, so as to enable either eye to be adjusted against *O*. The subject having taken

his position covers one eye and fixes the eye that is to be examined on the mark at *f*. The quadrant is then placed, say in the vertical meridian, and at the back of the wheel which revolves with the quadrant is inserted in the frame a special chart adapted for recording

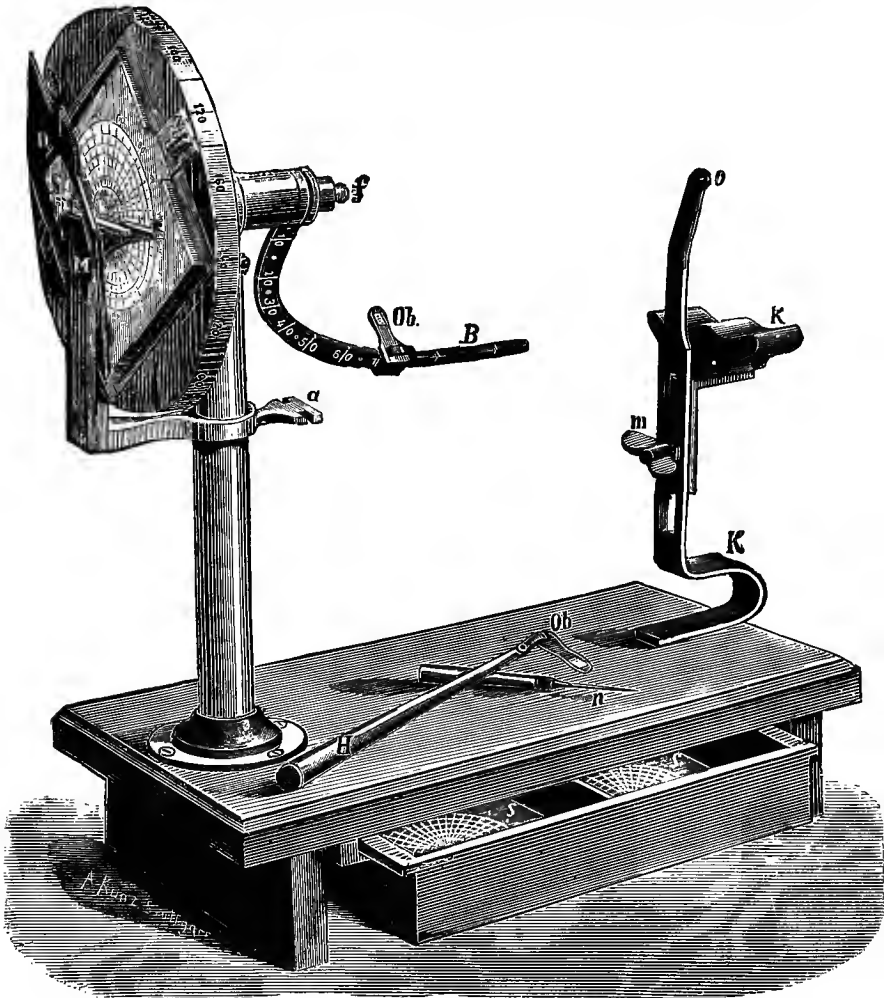

FIG. 219. —The perimeter.

perimetric observations. Starting at the extreme distance the mark *Ob* is gradually moved along the quadrant and at a certain angle the white spot will be just visible. The angle indicates the limit of vision in this meridian and can be recorded on the chart. Similar observations

are made in other meridia. In this manner the limits of vision in the different meridia of the field of vision can be recorded.

It is of course essential that the subject keep his eye fixed on f the whole time the spot is being moved.

The area bounded by a line drawn through the limiting points in the different meridia is properly the area of the field of vision. It is, however, often desirable to refer this area to the retina. If the meridia be inverted, the figure traced would then correspond to the sensitive portion of the retina. It will be found that perimeters are generally so constructed that the limiting marks in the different meridia are inverted on the chart, so that the latter becomes a chart of the extent of the sensitiveness of the retina. This is indicated in the figure above.

The Ophthalmoscope.—Prior to the invention of the Ophthalmoscope it was not possible to view the interior of the eye. The reason of this is that when the interior is illuminated an image of the source of illumination is formed in the retina, and the reflected light passing from the illuminated area out again from the eye will be subject to the refracting mechanism of the eye, and form a small image in the line of incidence of the source of light.

The Ophthalmoscope (Fig. 220) is really a contrivance to enable an observer to direct his vision along the axis of the pencil of light illuminating the subject's eye, and thereby to enable him to receive light reflected from the retina of the subject, in other words, to actually see the illuminated retina. The instrument consists essentially of a mirror, in which is a central aperture. The mirror is arranged so as to reflect light from some source through the pupil into the interior of the eye. The observer, looking through the central aperture, is able to view the illuminated posterior wall of the eye.

Two methods are usually adopted of using the ophthalmoscope, one being known as the *direct*, the other as the *indirect*. In the first case there is obtained an erect view of a small area of the retina, magnified

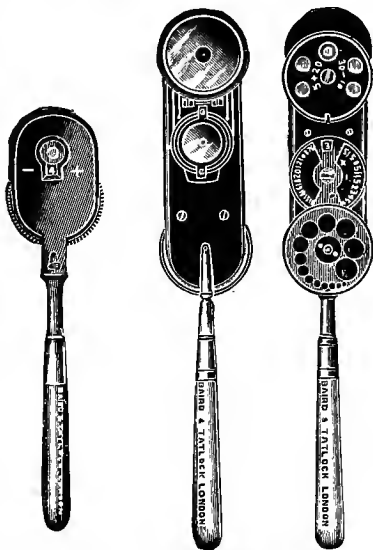

FIG. 220. —Ophthalmoscopes.

about thirteen times ; in the second case a less magnified and inverted view is obtained of a larger area of the retina.

The Direct Method.—The source of light is placed at the side of the head of the subject, so that no light falls directly on the cornea. The mirror, which is somewhat strongly concave, is held a few inches from the subject's eye, and is so tilted that light is directed into the pupil. The observer uses his left eye to examine the subject's left eye, and similarly his right eye for the subject's right eye. By bringing the light very close to the mirror, and this again close to the eye, the subject will not be able to accommodate for the image of the source of light, and consequently a dispersion circle of light will fall upon the retina. If the observer look through the aperture and the subject's eye be emmetropic he will obtain a clear view of the details of the retina. The reflected light from the subject's retina will issue as parallel rays and thus be in an appropriate state to impinge on the observer's cornea without requiring him to make any effort of accommodation.

The Indirect Method.—In this case a somewhat larger, but less concave or a plane mirror is used. The mirror is held at a distance of about eighteen inches, and if the accommodating power of the subject is intact his eye will accommodate for the source of light or its image formed by the mirror. An inverted image of the illuminated area of the retina will be formed at a certain distance behind the mirror. If the rays issuing from the eye be intercepted by a rather strong convex lens held close to the cornea a new image will be formed, smaller and more brilliant but still inverted. The observer then looks through the aperture of the mirror, and holding a lens as above against the cornea obtains a clear view of a considerable portion of the illuminated retina.

Ophthalmoscopes are generally supplied with a revolving disc of lens of different strengths, which are used to correct any error of refraction in the subject's or observer's eyes.

It is frequently a matter of difficulty to obtain a clear view of the back of the eye or fundus in the subject unless some drug previously has been applied which causes dilation of the pupil. For practice in the use of the ophthalmoscope, an albino rabbit, the eye of which has been treated with atropin, can be advantageously substituted for the human subject ; or artificial eyes, such as Frost's or Perrin's artificial eyes, may be used. In absence of these, the ocular of a microscope furnishes the material for the construction of an artificial eye. If the lower lens of this be removed and a disc painted to represent the fundus be inserted and blocked behind, an artificial eye is obtained which can be used with advantage.

HEARING.

CHAPTER LXXIV.

DISSECTION OF THE EAR IN THE SKATE.

AUDITORY SENSATIONS.

Ear of Skate.¹—1. Pare away the cartilage between the eyes of a skate. When the brain is reached continue the paring laterally, and in the cartilage at the side of the hinder part of the brain there will eventually be exposed one of the semicircular canals. When this is reached remove the upper wall as far as possible. In the hollow formed by the cartilage will be seen the fine membranous canal, dilating at one end into an ampulla. On continuing the exposure of the membranous canal it will be seen to join a rather large membranous sac, the utricle. Separated by a slight constriction is a smaller sac, the saccule, and at the anterior end of this is a small membranous projection which represents the cochlea.

2. Continue the dissection further so as to completely expose the three semicircular canals. Note also a tube leading towards the surface from the utricle, representing the recessus vestibuli.

3. Observe that the ampullae are more rigidly adherent to the cartilaginous walls than the length of the membranous canals. Open one such ampulla where comparatively free and note the crista acustica running transversely across the tube for about a third of the circumference.

AUDITORY SENSATIONS.

Range of Appreciation of Sound.—**EXPERIMENT.** In a room as free from noise as possible, let the subject sit with eyes closed and one ear plugged with cotton-wool. Let a watch be held in a line joining the

¹ A dog-fish can be used for this dissection.

two ears, and let it be placed opposite the open ear at such a distance that its ticking is just appreciable. In a quiet room this distance may vary from 2.5 to about 5 meters. Repeat the experiment with the other ear.

2. **Auditory Fatigue.**—The full effect of any sudden sound tends to temporary fatigue, to abolish appreciation of the fainter echoes which succeed it. If the full effect be avoided the fainter echoes may be heard.

EXPERIMENT I. Let a sudden intense sound (such as may be made by striking a bench with a hammer) be produced, (*a*) with the ears open, (*b*) with the ears closed for about half a second after the impact. In the first case the intense sound will alone be noticed, in the second case fainter echoes will be noticed in opening the ears.

EXPERIMENT II. Strike a tuning fork and place it on the crown of the head with gentle pressure. When the sound is no longer heard, remove it for a few seconds and then replace it again when the sound will be again appreciated.

EXPERIMENT III. Using a binaural stethoscope, sound a tuning-fork on a stand, and standing symmetrically with respect to the fork let the opening of the stethoscope be directed towards the fork. Then pinch one tube of the stethoscope, and the sound will be located by means of the patent tube only. When the sound has almost died away reopen the pinched tube, and now the sound will appear differently located and more intense to the ear which has not been fatigued.

3. **Appreciation of Pitch.**—**EXPERIMENT.** With Galton's whistle or some apparatus which will provide variation in pitch, observe the highest pitch in which tone can still be recognised. Conversely, note the lowest audible pitch in which tone can still be heard.

4. **Recognition of Absolute Pitch.**—By practice a trained musician can name the pitch of different tones. Education is required more for this probably than in naming fine differences of colour.

EXPERIMENT. Sit with the back to a piano and name the notes struck at random by the observers. In many cases this experiment may be impracticable.

5. **Beats.**—If two tones of different pitches be produced at the same time they mutually interfere and the resultant sensation is marked by a rhythmic variation in intensity, and is described as characterised by *beats*.

EXPERIMENT I. Put two tuning-forks of different pitches into vibration, and frequently the rhythmic beating is easily recognised.

EXPERIMENT II. Take two tuning-forks which produce beats when simultaneously caused to vibrate. Place one at such a distance from the ear that it can scarcely be heard. Bring the other fork gradually closer to the ear and the beats will be recognised.

6. Compound Tones.—The tones produced by musical instruments are not simple tones, but blended with other so called **overtones**. The lowest tone of the group gives the **fundamental** tone.

EXPERIMENT. Stretch a violin string between two fixed points. Set this into vibration by pulling it near one end, and immediately touch it in the centre with the finger. The tone will seem to be pitched an octave higher. The fundamental tone of the original group is obliterated, and the lowest tone now is an octave higher, and thus a new fundamental with other less evident overtones give the tone to the group.

7. Location of Tones.—**EXPERIMENT I.** Sound a large tuning-fork and press it against the vertex. The sound will appear to come from inside the head. Then close one ear, and the sound will seem to be localised in the other ear.

EXPERIMENT II. Sound a tuning-fork as above and note the effect of placing it on different parts of the head.

EXPERIMENT III. Sound a tuning-fork and let its foot rest upon the teeth. Close one ear and localise the apparent change in position of the sound.

PART II.

PHYSIOLOGICAL CHEMISTRY.

INTRODUCTION.

PHYSIOLOGICAL Chemistry, Chemical Physiology, or Bio-chemistry, is the subject which treats of the chemical processes connected with life. It comprises a study of the chemical constitution of the various tissues and of the chemical nature of the interchanges undergone by the food-stuffs in their passage through the organism.

The chlorophyll in the leaves of green plants absorbs certain of the spectral rays of sunlight (the red, yellow and orange) and utilizes the absorbed energy to bring about a reduction of carbon dioxide and water. In this process oxygen is evolved and there is formed a carbohydrate in which the energy absorbed from the light becomes locked up in potential form, as the carbohydrate can again combine with oxygen with the liberation of energy. A chemical synthesis is said to occur, and although simple carbohydrates are invariably the first products of this synthesis that we can isolate, yet, by further chemical transformations of the same nature, more complex carbohydrates, fats and proteins are evolved.

Animals eat the products of plant life and decompose them so as to liberate the potential energy, that is to say, to convert it into kinetic energy, which is then used in the functions of the animal body. The ultimate source of animal energy is, therefore, certain of the sun's rays. In thus decomposing the large molecules supplied them by the plant animals absorb oxygen and evolve carbon dioxide which again the plants absorb and thus complete the cycle.

Plants with no chlorophyll—such as the parasites and saprophytes, etc.—cannot perform these syntheses, but like animals they absorb oxygen, decompose complex molecules and liberate carbon dioxide. Even green plants exhibit this latter process, although in day light it is masked by the more active synthetic changes. In the dark, however, green plants behave like chlorophyll-free plants.

All the food-stuff digested by the animal is not decomposed, a certain amount of it being used in order to build up the tissues themselves (*e.g.* muscle, glands, etc.), and a certain amount being laid aside as storage material (*e.g.* fat, glycogen), which the organism can use as food in times of need.

The chemical substances which exist in the food-stuffs and tissues may be divided into inorganic and organic, the former include water and the mineral salts, and the latter consist of organic compounds containing the elements carbon, oxygen, hydrogen, and, in some cases, nitrogen. The organic substances are divided into two groups depending on whether or not they contain nitrogen. The nitrogenous food-stuffs include protein, which is the most important constituent of the tissues, and without which, as a food-stuff, animal life is impossible. The non-nitrogenous food-stuffs include the fats and carbohydrates, both of which may be regarded as combustion materials; fat, moreover, is the principal storage substance for surplus food-stuff assimilated.

The chemical composition of fats and carbohydrates is fairly accurately known, but at the present date we are only beginning to understand the structure of the apparently much more complex protein molecule. Much less do we know of the chemical constitution of living protoplasm of which protein is the chief constituent, for living matter cannot be analysed since it is killed by the process of analysis, and the results obtained show only the decomposition products of dead matter.

These bodies, fats, proteins, and carbohydrates, really represent the elementary constituents of the organism, and they are frequently called the 'proximate principles.'

We shall first of all study the chemical nature of the proximate principles, then the variety and amount of these contained in the various tissues and foods. We shall then be in a position to investigate the nature of the chemical interchanges in the organism, and, in order to do this, we shall require to study the chemical composition of the various excretory bodies given off in the urine and other excreta.

CHAPTER I.

CARBOHYDRATES.

Chemical Relationships.—These are compounds of carbon, hydrogen, and oxygen, in which the latter two elements usually exist in the same proportion as in water. Their general formula is therefore $C_m H_{2n} O_n$.

Carbohydrates are found chiefly in vegetable tissues, but also occur in animal tissues. They form very important food stuffs, for they are easily digested and assimilated, and moreover are much cheaper than proteins and fats. (See Diet.) The simplest form of carbohydrate is called a *monosaccharide*, and all other carbohydrates can be broken down into two or more monosaccharide molecules by the chemical process of hydrolysis. When, by this process, two monosaccharide molecules are produced, the carbohydrate is called a *disaccharide*; when more than two are produced, the carbohydrate is called a *polysaccharide*. The monosaccharides and disaccharides being sweet to the taste are together spoken of as sugars.

I. MONOSACCHARIDES.

Chemically considered, monosaccharides are either aldehydes or ketones; the former are called aldoses, the latter ketoses. The aldoses are classed according to the number of carbon atoms in the molecule, e.g. pentose $C_5H_{10}O_5$, hexose $C_6H_{12}O_6$.

Aldoses.—An aldehyde is the first oxidation product of a primary alcohol, and it contains the end group — CHO.

A *primary* alcohol is one in which the "OH" or "hydroxyl group" is attached to the last carbon atom of the molecule—as in primary propyl alcohol,

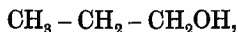

and it contains the end group — CH_2OH . If, on the other hand, the hydroxyl group be attached to a central carbon atom—as in secondary propyl alcohol,



the alcohol is called *secondary*, and contains the group — CHOH.

Thus, if ethyl alcohol be heated with potassium bichromate and sulphuric acid, it is oxidised and acetic aldehyde is formed:

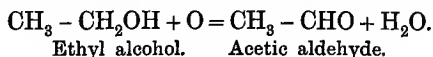

This group, - CHO, is, however, not a stable one, but very readily undergoes further oxidation to produce the acid (carboxyl) radicle - COOH,

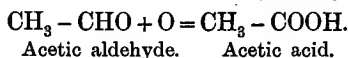

As a consequence of this tendency to absorb oxygen aldehydes are strong *reducing agents*, and it is this property which constitutes one of their most important group reactions, for the reaction is frequently accompanied by a visible change in the colour of the solution.

Their power of reducing cupric hydroxide, which is blue in colour, to cuprous oxide, which is red, and of reducing silver nitrate to metallic silver, is of especial value as a test. Similar reactions are obtained with certain bismuth and mercury salts. In order to produce these reactions, it is necessary that the liquid be alkaline in reaction.

EXPERIMENT I. Demonstrate the reducing power of a simple aldehyde, such as formaldehyde, on cupric salts in alkaline solution. Place one drop of a weak solution of cupric sulphate in a test tube. Add about ten drops of formalin (40% formaldehyde), and then, drop by drop, a strong solution of caustic soda. The first drop or so of the latter produces a precipitate of cupric hydroxide, but this afterwards becomes redissolved, provided there be only a trace of copper present. Now boil and note that a red or yellow precipitate of cuprous oxide is produced. This is called Trommer's test. The chemistry of the reaction is illustrated by the following equations:—

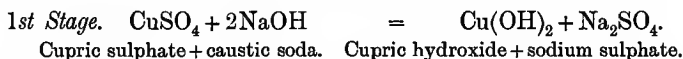

The cupric hydroxide is kept in solution by the aldehyde to form a clear blue solution. By heating it is believed that a hypothetical cuprous hydroxide is formed, thus:—

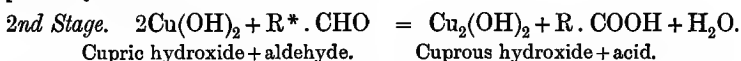

The cuprous hydroxide then loses a molecule of water and changes into the oxide: $\text{Cu}_2(\text{OH})_2 - \text{H}_2\text{O} = \text{Cu}_2\text{O}$.

EXPERIMENT II. Demonstrate the reduction of silver nitrate by a simple aldehyde. Place about 5 c.c. of an ammoniacal solution of silver nitrate (prepared by adding ammonia to a solution of silver nitrate till the precipitate formed just redissolves) in a test tube, and add to it about ten drops of formaldehyde. Boil. Reduction takes place, and the metallic silver is deposited as a mirror on the wall of the test tube: $\text{Ag}_2\text{O} + \text{R} \cdot \text{CHO} = 2\text{Ag} + \text{R} \cdot \text{COOH}$.

* R stands for the more or less complicated group or radicle to which the - CHO group is attached. In the case of formaldehyde this is H.

Reactions of Monosaccharides depending on the fact that they are aldehydes.

I. Their Reducing Power.—Dextrose is the aldehyde corresponding to the hexatomic¹ alcohol, sorbite.

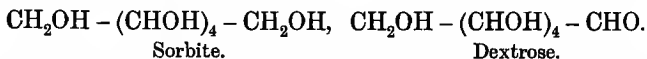

It, therefore, manifests strong reducing powers on metallic oxides in alkaline solution.

EXPERIMENT III. Demonstrate the reducing power of a monosaccharide, such as dextrose on cupric salts in alkaline reaction.

Trommer's Test.—Place a few drops of a weak solution of cupric sulphate in a test tube; add about 5 c.c. of a 1% solution of dextrose, and then, drop by drop, a 20% solution of caustic soda until the precipitate of cupric hydroxide, which at first forms, becomes re-dissolved, and a clear blue solution is obtained. Boil. Reduction is effected, a red precipitate of cuprous oxide resulting.

Repeat experiment without the addition of dextrose. A black precipitate of cupric oxide is obtained on boiling with excess of caustic soda.

EXPERIMENT IV. *Fehling's Test.*—This differs from Trommer's test in that tartrate of sodium and potassium (Rochelle salt) is added to the mixture of CuSO_4 and NaOH .² Rochelle salt has the property of dissolving cupric hydroxide forming a blue solution, which is unaltered on boiling, and is therefore of especial value when the solution to be tested contains only a small amount of dextrose or other reducing substance. Boil a few c.c. of Fehling's solution in a test tube. Add the dextrose solution drop by drop, with continued boiling, until reduction results, as evidenced by the blue colour being diminished and an orange red precipitate settling down.

EXPERIMENT V. *Nylander's Test.*—To about 5 c.c. of dextrose solution in a test tube add about 1 c.c. of Nylander's reagent (a solution containing 10% caustic soda, 4% Rochelle salt and 2% bismuth subnitrate). Boil for two minutes. A black precipitate of bismuth forms. Some substances (creatinin, uric acid) which reduce Fehling's solution do not give this test. As regards the sugars, however, where Fehling's test is positive this test will also be positive.

¹ A hexatomic alcohol is one which contains six OH groups. Glycerine is called tri-atomic, because it contains three such groups. Ethyl alcohol is mon-atomic, because it contains one.

² For the exact formula for Fehling's solution see p. 450.

EXPERIMENT VI. Boil some glucose solution with Barfoed's solution (acid cupric acetate). Reduction occurs. This test applies to the monosaccharides only. Disaccharides do not reduce Barfoed's solution.

EXPERIMENT VII. Demonstrate that dextrose also reduces ammoniacal silver nitrate to metallic silver.

II. *Monosaccharides form compounds called Osazones, with Phenyl Hydrazine.*—The compounds are very useful in identifying the various forms of sugars, as each sugar forms a slightly different compound. They are also of great interest because it was by producing them that Emil Fischer was able to convert one sugar into another and thus to discover the chemical constitution of the sugars.

EXPERIMENT VIII. The production of osazones. Add .25 gm. (enough to cover a sixpence) of phenyl-hydrazine hydrochloride and an equal bulk of sodium acetate crystals to about 10 c.c. of a 1% solution of dextrose. Warm gently till everything is dissolved, and then place for half an hour in a boiling water bath. Allow to cool, when a yellow precipitate of glucosazone will separate out. Examine this under the microscope, and notice that the precipitate is composed of branching needle-shaped crystals arranged in rosettes or sheaves (Fig. 221).

The chemical reaction takes place in two stages, the intermediate body being called a hydrazone.

The formula for osazone is

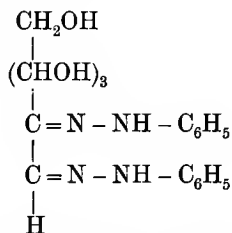

The excess of sodium acetate in the above mixture reacts with the phenyl-hydrazine hydrochloride so as to form the acetate.

When it is desired to produce osazones from dilute sugar solutions, a more certain way to proceed is as follows: Mix two drops of phenyl-hydrazine (fluid) with ten drops glacial acetic acid and add to this 5 c.c. of the sugar solution, shake, and place the test tube for one hour in the boiling water bath. After cooling examine under the microscope for the crystals. With stronger sugar solutions this method yields crystals after a few minutes' heating.

The advantage of the phenyl-hydrazine hydrochloride is that it does not readily decompose on keeping, whereas the free base does.

The osazone crystals are valuable for distinguishing between the different sugars. Besides microscopical examination, a determination of the melting point

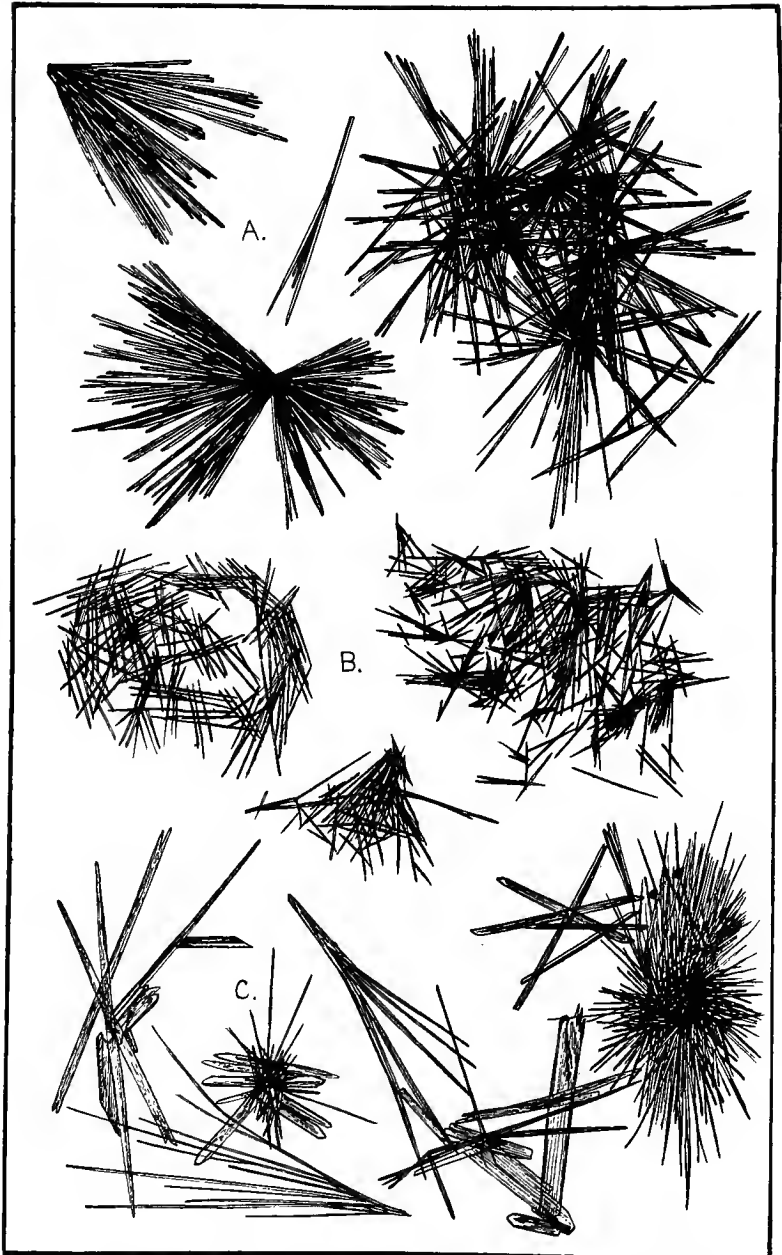

FIG. 221.—Osazone crystals. $\times 400$.

A, Phenyl-glucosazone; B, Phenyl-maltosazone; C, Phenyl-lactosazone.

is often of value. For this purpose the crystals of osazone are collected on a filter paper, washed with water acidulated with acetic acid, recrystallised from water, alcohol or acetic acid, and dried by placing in a desiccator over H_2SO_4 . They are then placed in a narrow glass tube closed at one end and tied on to the bulb of a thermometer by a fine platinum wire. The thermometer is suspended in a long necked Jena flask in which is concentrated H_2SO_4 (almost saturated with K_2SO_4 to prevent fuming) and the temperature gradually raised by heating the flask over wire gauze. The bulb of the thermometer should dip into the sulphuric acid. The exact temperature at which the crystals begin to melt and the temperature of complete fusion are noted. For accurate work, a correction is necessary because the mercury thread is cooler than the bulb of the thermometer.¹ and ²

The following are the melting points of some of the most important osazones :

Dextrosazone, ³	-	-	204-205° C.
Lactosazone,	-	-	200° C. (Begins to melt at this temp.)
Maltosazone,	-	-	206° C.

If the crystals are pure, melting occurs at once, but if they are impure there may be a considerable difference in temperature between the points of commencing and complete fusion.

If an osazone be hydrolysed by treating with fuming HCl it breaks up, phenyl-hydrazine being set free, and a body called an osone resulting. This latter has the formula $CH_2OH - (CHOH)_3 - CO - CHO$, from which it is seen that it contains both an aldehyde and a ketone group. The former of these groups can be converted into the CH_2OH group of sugar by treating with a reducing agent,

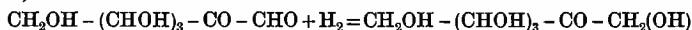

which is the formula for laevulose (a ketose).

The aldoses can thus be changed into the ketoses, and if the aldose obtained by condensation of formaldehyde be used as the starting point an interesting synthesis from a simple aldehyde to a more complex one and then to a ketose is illustrated. It is believed by some that formaldehyde is the chemical substance which, by a process of reduction, chlorophyll-containing plants first form from CO_2 and H_2O . By condensation of several (five or six) formaldehyde molecules pentoses or hexoses become formed, and from these the more complex carbohydrates. By other chemical actions fats and proteins can then be produced.

III. The simple sugars can be artificially prepared by careful oxidation of

¹To make the above correction, a second thermometer must be suspended in the flask with its bulb opposite the middle of the column of mercury of the main thermometer, the formula for correction is then $L(T-t)(0.000154)$ where L = the height of the mercury column of the main thermometer above the sulphuric acid measured in degrees; T = the reading of the main thermometer; t the reading of the air thermometer. This correction must be added to the reading T of the main thermometer.

²Too much reliance must not be placed on a determination of the melting points of osazones in identifying unknown sugars, for they vary with the rate of heating and with the method of purification of the osazone.

³Laevulose forms the same osazone as dextrose.

the corresponding alcohols or by reduction of the corresponding acids.—There are three hexatomic alcohols differing from one another in their constitutional formulae. From each of these a different aldose (or ketose) can be produced by oxidation, and the aldoses can be further oxidised to form three different mono-basic acids, or further still, to form three di-basic acids, thus :

Alcohol.	Aldose.	(Ketose).	Mono-basic ¹ Acids.	Di-basic ² Acids.
Sorbite	Dextrose	(Laevulose)	Gluconic	Saccharic
Mannite	Mannose	(Laevulose) ³	Mannonic	Mannosaccharic
Dulcitol	Galactose	—	Galactonic	Mucic

Another monobasic acid is glycuronic— $\text{CHO} \cdot (\text{CHOH})_4 \cdot \text{COOH}$ which differs from gluconic, etc., in the fact that oxidation has occurred at the C atom furthest removed from the aldehyde group. Its physiological importance will be discussed in the chapter on urine.

Ketoses.—As mentioned above, some carbohydrates belong to the group of substances called ketones. A ketone is the oxidation product of a secondary alcohol and it contains the group— CO —which is situated somewhere in the chain between other groups and not at the end of it as in the case of the $-\text{CHO}$ group of the aldehydes. The simplest ketone is acetone $\text{CH}_3 - \text{CO} - \text{CH}_3$ which may be obtained by oxidation of secondary propyl alcohol,

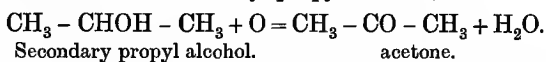

Ketones form compounds with phenyl hydrazine, but only some of them reduce metallic oxides in alkaline solution. Those ketones which belong to the carbohydrates manifest this reducing power. The only well-known ketose is laevulose. There are several reactions characteristic of ketoses, of these the following is important.

EXPERIMENT IX. Selivanoff's Test.—Mix a few cubic centimetres of a solution of laevulose with half its volume of concentrated HCl. Add a few crystals of resorcin and heat the mixture. A deep red colour develops and later a brown precipitate. The colour can be extracted by shaking with amyl alcohol.

Repeat this experiment with pure dextrose solution instead of laevulose. A slight red colour develops but no precipitate.

¹ The formula for these monobasic acids is $\text{CH}_2\text{OH} - (\text{CHOH})_4 - \text{COOH}$.

² The ,, ,, dibasic ,, $\text{COOH} - (\text{CHOH})_4 - \text{COOH}$.

³ Laevulose when oxidised does not form the same products as mannose or dextrose but breaks down into products with fewer carbon atoms than itself. This is because it is a ketose.

CHAPTER II.

CARBOHYDRATES—CONTINUED.

OTHER REACTIONS OF CARBOHYDRATES.

THERE are, however, other reactions of carbohydrates which do not depend on their being aldehydes or ketones. The most important of these are :

I. Molisch test.—This is an extremely sensitive test, being especially suitable for the detection of minute traces of carbohydrate. For example, most proteins (*e.g.* egg albumin) give it, on account of the carbohydrate groups which they contain.

EXPERIMENT I. To about 2 c.c. of a very dilute sugar solution, or of a strong solution of egg albumin, add a drop of a saturated alcoholic solution of α -naphthol. Then carefully pour about an equal volume of pure concentrated H_2SO_4 down the wall of the test tube so that it forms a layer at the bottom. On standing a minute or so a deep violet ring forms at the line of contact of the two fluids. The greenish colour which also develops is due to the reagents and is no part of the test.

II. Fermentation with Yeast.—By allowing yeast to grow on a solution of dextrose, the latter is split up into alcohol and carbon dioxide,

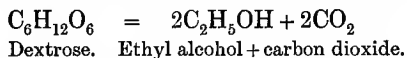

All carbohydrates do not give this reaction, so that it is of value as a distinguishing test for the presence of dextrose in the urine. Commercially it is the agency employed in the preparation of alcoholic beverages.

To ascertain whether the addition of yeast to a solution produces fermentation, the process should be allowed to proceed in an inverted tube over mercury, or in a Southall's ureometer (see Fig. 244), so that any carbon dioxide gas which develops may be collected, and if necessary tested.

EXPERIMENT II. Shake up a 1 per cent. solution of dextrose, which has been previously boiled to expel the air and then cooled, with a piece of yeast the size of a split pea. Pour the opalescent solution thus obtained into a Southall's ureometer (p. 421) so that it completely fills the vertical tube. Now place the tube aside in a warm place for some time, when it will be found that a certain amount of gas has collected at the top of the tube. This gas is CO_2 as can be shown by

adding some NaOH to the tube by means of a pipette and shaking: the gas disappears. As a control, a tube filled with water and yeast should also be incubated. This should yield no gas.

EXPERIMENT. Repeat the above experiment with similar solutions of maltose, lactose and cane sugar, and note that, after 24 hours, lactose has not undergone any fermentation, whereas it is marked in the case of maltose; cane sugar also shows a certain amount of fermentation. Yeast contains an invertase (maltase) which readily hydrolyses maltose into dextrose, on which the zymase of the yeast then acts, forming alcohol and carbon dioxide. Another invertase in the yeast acts on cane sugar. These invertases have no action on lactose.

III. Rotation of Polarised Light.—All simple carbohydrates rotate the plane of polarisation of polarised light to the right except laevulose, which rotates to the left.

This effect is due to the presence in the molecule of asymmetrical carbon atoms.

6 carbon aldose (hexose).

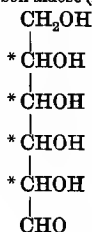

6 carbon ketose.

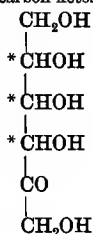

* Denotes an asymmetrical carbon atom.

Examination of the above formulae shows that the aldoses contain four asymmetrical carbon atoms, whilst the corresponding ketoses contain only three. The different arrangements in space of the hexose carbon atoms allow of the existence of sixteen different hexoses, of which twelve have been identified. Only two, however, are of physiological importance, dextrose and galactose. The different spacial arrangement of the atoms in the molecule accounts for the difference in rotatory powers shown by these aldoses and also for slight differences in chemical properties, such as crystalline form and melting point of the osazones.

Polarisation of Light.—When two slices of tourmaline, a semi-transparent mineral, are cut parallel to the axis of the crystal and laid over one another, it will be noticed that the amount of light which passes through the combination varies according to the relative positions of the two slices to one another. If the slices be at right angles to one another no light passes through, and in intermediate positions only a certain amount, so that an opaque combination is obtained. A ray of ordinary light contains vibrations in all planes passing through the ray; but when the light passes through a tourmaline plate it vibrates in one plane only. Ordinary light may, therefore, be likened to a wheel, the axle representing the ray of light and the spokes the planes along which it vibrates. On passing through the tourmaline plate, however, the

light is capable of vibrating in one plane only, which would correspond, in our example, to two opposite spokes. The light which vibrates in one plane is called plane-polarised light, and cannot be distinguished by the naked eye from ordinary light. By placing a second, similarly cut, tourmaline plate in its course, however, it can be detected, for it will pass through this only if its axis corresponds to the axis of the first plate. The first plate is called the *polariser* and the second plate the *analyser*. The mechanism of this action of the analyser and polariser can be easily illustrated by a piece of string stretched between two posts; it can vibrate in all planes. If a comb be placed in the course of the string the vibrations can only take place along one plane corresponding to the direction of the teeth of the comb. This comb represents the polariser. If now, a second comb be placed along the string it will permit the vibration of the string or stop it, according to the position of its teeth; if these be in the same direction as those of the first comb the string will go on vibrating, but if they be placed at right angles the string will cease to vibrate. Polarisation of light by tourmaline illustrates the principle of the polarimeter but in this instrument itself it is found more convenient to use a polariser and analyser made of a *Nicol's prism*. A Nicol's prism consists of a crystal of Iceland spar. Such a crystal has the power of splitting light into two rays, one of which, the *ordinary ray*, passes through it as it would through glass, and the other one, the *extraordinary ray*, is more refracted. Consequently, on looking at a dot on a sheet of paper through a piece of Iceland spar laid flat on the paper, a double image of the dot is obtained, and if the crystal be rotated, one of the dots—the extraordinary ray—will be seen to move round the other—the ordinary ray—which remains stationary. Now both these rays are polarised, but in different planes. If the crystal be cut across along a diagonal line and the two surfaces re-cemented by means of Canada balsam, the ordinary ray, when it meets the balsam, will be totally reflected and pass out at the side of the crystal, whereas the extraordinary ray will be transmitted through the balsam, and will finally emerge at the end of the prism, parallel to its original direction; but, of course, plane polarised. To detect the polarisation a similarly constructed prism, or analyser, must be used.

Certain other bodies, *e.g.* a quartz plate, a solution of sugar or albumin, have the power of *rotating the plane of polarised light*. Thus, supposing that the plane polarised light vibrates along a vertical plane, one of these bodies will cause it to vibrate in an oblique plane. If the analyser be so placed that none of the plane polarised light can pass through it (*i.e.* the field is black), and if a piece of quartz be inserted between the polariser and analyser, it will be found that now a certain amount of light passes through the analyser (*i.e.* the field becomes opaque), and, in order to obtain darkness again, it is necessary to rotate the analyser in the direction of the hands of a watch, as seen by the observer. Consequently, rotation has taken place to the right, *i.e.* dextro rotation is said to have occurred. If a solution of albumin or laevulose be employed the rotation of the analyser must be to the left, *i.e.* against the hands of the watch. When the plane of white light passes through the quartz plate, however, the various colours of the spectrum are rotated to a different degree, so that, instead of having a mere opacity (as is the case with intermediate positions of two 'tourmaline' plates) different colours are obtained according to the amount of rotation. There are also samples of quartz which rotate the plane of light to the left.

Dextrose and a quartz plate produce the same amount of rotation, and therefore it is possible to determine the rotatory power of a solution of the former by compensating its rotation by means of a quartz plate of known rotatory power.

We are now in a position to understand the construction of a **polarimeter** or **saccharimeter**. It consists of the following parts:

(1) A Nicol's prism, called the *polariser*. This polarises light in a vertical plane.

(2) A biquartz, or other device for rotating, in opposite directions, the two halves of a polarised beam. A biquartz consists of a disc of quartz made of two semicircular halves of equal thickness, but of opposite rotatory powers.

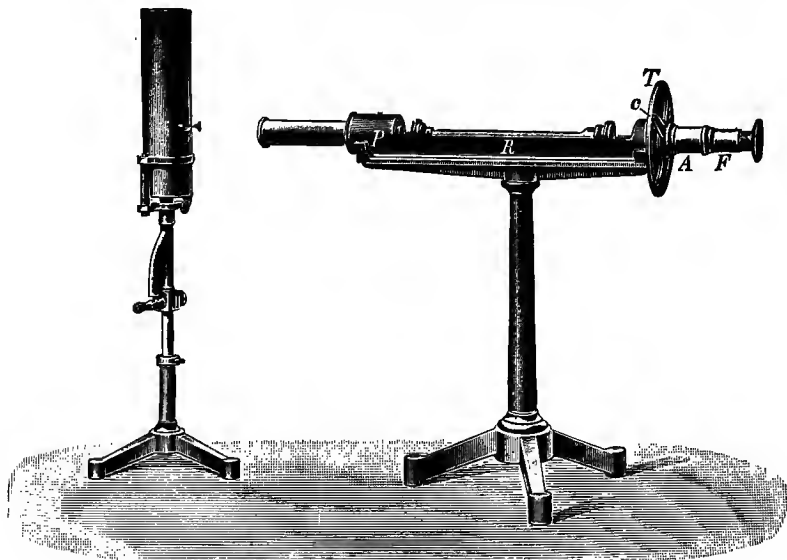

FIG. 222.—Polarimeter of Mischerlich with Laurent's polariser. *P*, polariser and device for obtaining half shadow; *R*, fluid container; *T*, scale with vernier *c* attached to pointer; *A*, compensator and analyser; *F*, lens.

Each half is of such a thickness that it rotates the plane polarised light to 90° in opposite directions so that, on emerging from the disc the plane of light is now horizontal. Instead of a biquartz many instruments contain a semi-circular plate of quartz.

(3) A tubular **liquid holder** to hold 10 c.c of the liquid to be examined. If the length of this tube be 188.6 mm. the amount of rotation in angular degrees will correspond to percentage of dextrose in the fluid (*e.g.* urine) examined.

(4) **A Compensator**.—This shows how much rotation has been produced by the solution. It is connected with a scale representing angular degrees, and the pointer carries a vernier, so that tenths of a degree can be read off. In some instances the compensator consists of two wedge-shaped pieces of quartz, so arranged on one another that the total thickness of quartz inter-

posed in the path of the polarised beam can be varied by means of a screw. In other instruments the quartz plates are dispensed with, the amount of rotation being measured by rotating the next part of the instrument, namely the

(5) **Analyser**, so as to obtain uniformity of tint in the two halves of field.

(6) **A Lens**.

When the tube (3) is filled with water or an optically inactive fluid, and the compensator or analyser rotated until a violet colour of uniform tint fills the field, the indicator will be seen to stand at zero (if not so, the error must be noted). If now, an optically active fluid be placed in the tube the two halves of the field will become of different tints, *i.e.* rotation of the plane of polarised light has occurred. In order to measure the amount of this rotation, we must move the screw or pointer connected with the compensator or analyser until the uniform tint is again obtained.¹ The amount of 'compensation' necessary is read off on the scale and, if the holder be not 188.6 mm. long, the necessary calculation is made in order to ascertain the strength of the solution (for formula see below).

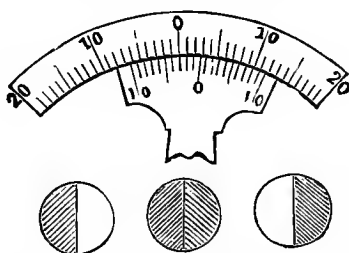

FIG. 223.—Diagram of scale and field of vision of polarimeter. Above is represented the scale for measuring the compensation necessary. In the position represented in the diagram the reading is 2.7 dextro rotation. The lower part of the diagram shows the three appearances of the field of the polarimeter, the central one representing the appearance at zero, *i.e.* when there is no rotation.

To estimate the percentage of sugar in urine the chief precautions are, (1) to see that it is *perfectly clear*, and (2) to see that it contains no protein.

In order to obtain a specific or comparative number (*i.e.* a result always obtained under the same conditions) it is necessary to adopt a standard. This consists of the rotation, in degrees of a circle, produced by 1 gr. of the substance dissolved in 1 c.c. of fluid and contained in a tube 1 dcm. long. This is called the *specific rotatory power* and is represented by $(\alpha)D$.² It is determined by the following formula :

$$(\alpha)D = \pm \frac{\alpha}{p \times l},$$

where α = the observed rotation,

l = the length, in decimeters, of the tube in which the solution is placed,

p = the weight, in grammes, of the substance contained in 1 c.c. solvent.

The rotation produced by a substance depends upon its concentration in a solution; if, therefore, the index $(\alpha)D$ of any substance be known, and its

¹ In the best modern polarimeters the field is divided into three; when at zero these are of the same tint otherwise the central band takes a different colour.

² The 'D' indicates that sodium light is used.

rotation be ascertained, its percentage P in any fluid can be ascertained by the formula.

$$P = \frac{100\alpha}{sl}$$

where $s = (\alpha) D$.

For rapidly and accurately determining the percentage of sugar in any fluid (*e.g.* urine) the polarimeter—and especially that form of it in which the scale reads percentages of sugar—is a very valuable instrument. It is much used for this purpose in the continental clinics.

The Specific Rotatory Power¹ of certain of the sugars is as follows :

<i>Monosaccharides</i> :	Dextrose :	+52·7°.
	Galactose :	+81°.
	Laevulose :	-93°.
	Invert sugar :	-20·2°.

Disaccharides.—The $(\alpha) D$ of these carbohydrates changes when they are hydrolysed.

Cane sugar : +66·5°—after hydrolysis becomes laevorotatory (*vide* invert sugar).

Maltose : +137°—after hydrolysis becomes much less.

Lactose : +52·5°—after hydrolysis becomes slightly more.

IV. Moore's Test.—When heated with caustic soda a dark substance called caramel is produced. This is also produced when sugar is burnt. Caramel contains several chemical bodies, the most important of which is an acid called levulinic acid ($\text{CH}_3 - \text{CO} - \text{CH}_2 - \text{CH}_2 - \text{COOH}$).

EXPERIMENT III. Mix equal quantities of a 1% solution of dextrose, and 40% NaOH in a test tube; heat. A yellow to brown colouration results, and an odour of burnt sugar (caramel) is produced. This odour becomes very evident if, after cooling, the solution be acidified with H_2SO_4 .

The Chief Monosaccharides are dextrose, laevulose and galactose.

Dextrose, grape sugar or glucose ($\text{C}_6\text{H}_{12}\text{O}_6$), is found in many fruits, and is an important food-stuff. In the healthy animal body it occurs in the blood and muscles. In normal human blood the amount of glucose is usually from 0·1 to 0·15%, but in disease it may rise to such a degree that it appears in detectable amount in the urine (see p. 447). Commercially it exists as a syrup much used in making confections. It is easily crystallised.

It is soluble in water and in alcohol. It has only a slightly sweet taste. It rotates polarised light to the right ($(\alpha)D = +52·7$).

¹ The rotatory power of a solution of a sugar is frequently different when the solution is freshly made from what it becomes on standing. This phenomenon is called mutarotation. The figures given are all for solutions which have been kept long enough to be in equilibrium. Temperature also affects the rotatory power of a solution, particularly in the case of laevulose and invert sugar.

Glucose readily combines with alcohols, acids, phenols, etc., to form *glucosides*. These are resolved into their constituent groups by hydrolysis with acid. To understand their structure, the formula for glucose is best written with four of its C atoms in a ring thus:

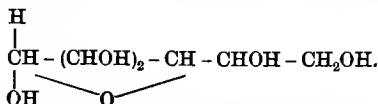

When the H atom of the hydroxyl group of the C atom which exercises aldehydic functions in the open chain formula for dextrose is replaced by some radicle a glucoside results. Since this C atom is assymmetric, two stereoisomeric glucosides (α and β) are possible. These show striking differences from one another in their susceptibility to ferment action.

Laevulose ($\text{C}_6\text{H}_{12}\text{O}_6$) is found along with dextrose in fruits and honey and results from the hydrolysis of cane sugar (see Disaccharides). It is very rarely found in animal tissues. It is crystallisable with great difficulty, being usually obtained as a putty-like mass. It is laevorotatory ($(\alpha)\text{D} = -93^\circ$).

Galactose ($\text{C}_6\text{H}_{12}\text{O}_6$) is a dextro-rotatory sugar produced, along with dextrose, by hydrolysing lactose (see Disaccharides). Protagon, a lipid substance in brain tissue, yields galactose on hydrolysis. Certain gums also yield it on hydrolysis. It differs but slightly from dextrose in its reactions. Its presence can be detected by the fact that when oxidised, as by boiling with nitric acid, it yields mucic acid (see p. 278) which forms characteristic crystals.

EXPERIMENT. Test for galactose. Add 3 c.c. pure HNO_3 (con.) to 10 c.c. of a strong solution of lactose in a small evaporating dish. Boil gently over a free flame for three minutes, and then gently lower the flame and allow to evaporate till the volume is reduced to about 3 c.c. Transfer to a test tube, cool under the tap, add 2 c.c. water, and allow to stand. Crystals of mucic acid separate out.

II. DISACCHARIDES.

Chemically, each molecule of a disaccharide consists of two molecules of a monosaccharide less one molecule of water,

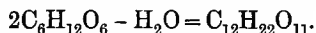

Their structure can be demonstrated by hydrolysing them, *i.e.* by causing them to take up a molecule of water, in consequence of which they split up. In disaccharides the two monosaccharide molecules are linked together in the same manner as glucose and the other constituent radicle in glucosides.

The chief means of hydrolysing include boiling with *dilute* acid and the action of certain ferments called invertases, which are contained in

the succus entericus and in the protoplasm of many cells such as the yeast plant (see p. 280).

The members of this class are cane sugar, maltose and lactose, and of these cane sugar does not reduce metallic oxides in alkaline solution, nor does it form an osazone, whereas lactose and maltose give both these reactions. With yeast maltose and cane sugar are first hydrolysed, and the monosaccharides thus produced then undergo alcoholic fermentation.

Cane Sugar ($C_{12}H_{22}O_{11}$) is the common sugar obtained from sugar cane, beet root, etc. It is very soluble in water and has a sweet taste. It does not reduce metallic oxides in alkaline solution.

EXPERIMENT IV. Perform Trommer's test with some cane sugar solution. Notice that, although no reduction occurs, the cane sugar, like other sugars, is capable of holding the cupric hydroxide in solution, so that a clear blue colour is produced.

By hydrolysis, reducing sugars (dextrose and laevulose) are developed.

EXPERIMENT V. Boil some cane sugar solution with a few drops of 25 % sulphuric acid. Now neutralise the acid and apply Trommer's or Fehling's test and note that reduction occurs. The monosaccharides developed are dextrose and laevulose, the mixture being called invert sugar.

It is often better to employ an organic acid such as citric acid to produce the hydrolysis, because the organic acid does not hydrolyse starch or glycogen, whereas mineral acids do.

EXPERIMENT VI. Apply Seliwanoff's test for ketose to a solution of cane sugar (Experiment IX. p. 278). The reaction is as marked as for laevulose, owing to hydrolysis of the cane sugar by the hydrochloric acid employed.

EXPERIMENT VII. Heat some cane sugar solution with strong hydrochloric acid. Note the reddish colour developed. This reaction is given by other sugars, but not so readily.

A solution of cane sugar is dextro-rotatory ($(\alpha)D = +66.54$), but after hydrolysis it is laevo-rotatory, the laevo-rotatory power of the laevulose being stronger than the dextro-rotatory power of the dextrose formed. On this account the process of hydrolysis is sometimes called inversion, and the hydrolysing ferments in the succus entericus, etc., are often called invertases.

EXPERIMENT. Examine a ten per cent. solution of cane sugar with the polariscope. Note the rotation and calculate $(\alpha)D$. Place exactly 50 c.c. of a twenty per cent. solution of cane sugar in a 100 c.c. measuring flask; add 1 gr. citric acid and boil over wire gauze for five minutes. Cool, neutralise with NaOH solution, and fill with distilled water to the 100 c.c. mark. Examine this solution with the polariscope and calculate $(\alpha)D$.

Lactose ($C_{12}H_{22}O_{11}$) is the sugar found in milk, and it has been detected in the urine of nursing mothers.

It is not very soluble in water, and is quite insoluble in alcohol and ether. It has only a slightly sweet taste. It does not ferment with yeast in 24 hours, but it undergoes a special fermentation with the *bacillus acidi lactici* which develops in sour milk. This fermentation results in the production of lactic acid.

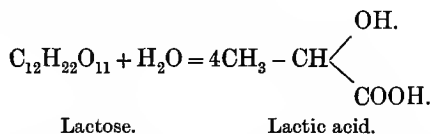

By hydrolysis it yields dextrose and galactose. It reduces metallic oxides in alkaline solution. It is dextro-rotatory ($(\alpha)D = 52.5$). By oxidation with nitric acid it yields mucic acid (cf. p. 278).

Maltose ($C_{12}H_{22}O_{11}$) is important physiologically because it is the sugar produced from starch by the action of ptyalin (the ferment of the saliva), of amylopsin (a ferment in the pancreatic juice) and of glycogenase (a ferment in the liver, blood serum, etc.). Maltose is therefore mainly an intermediary substance in the animal body.

Maltose is also produced by the action of malt diastase, which is obtained by moistening barley and allowing it to germinate in heaps at a constant temperature. The diastase acts on the starch of the grain and produces maltose. The product when dried is called *malt*. When malt is dissolved in water, and the yeast plant allowed to grow on the solution, malted liquors, such as beer and ale, are obtained. In this process the maltose is first of all inverted into two molecules of dextrose by the invertase contained in the yeast, and the dextrose then undergoes alcoholic fermentation.

It reduces metallic oxides in alkaline solution, but is feebler in this regard than dextrose. It rotates the plane of polarised light more strongly than dextrose ($(\alpha)D = +137.04^\circ$). After hydrolysis, therefore, the reducing power shows an increase and the rotatory power a decrease.

EXPERIMENT VIII.—Boil lactose or maltose solution with Barfoed's reagent (Experiment VI. p. 275.) There is no reduction. This reagent is not reduced by disaccharides.

Isomaltose.—This sugar is closely related to maltose, differing from it in the fact that its osazone melts at a much lower temperature, $158^\circ C$. It has been prepared by pure chemical synthesis—*e.g.* the condensation of dextrose by strong acids. It is of special interest because it is probably the sugar produced as a result of the reversible action of maltase.

CHAPTER III.

CARBOHYDRATES—CONTINUED.

III. POLYSACCHARIDES.

A POLYSACCHARIDE is the condensation product of more than two monosaccharide molecules, and has accordingly the general formula, $(C_6H_{10}O_5)_n$, where n stands for a variable number.¹ Polysaccharides can be hydrolysed, in which process they yield, first of all, polysaccharides (dextrines) of lower molecular weight (*i.e.* with n of less value), then disaccharides and, finally, monosaccharides.

Thus, when acted on by diastatic ferments, dextrines (polysaccharides of lower molecular weight) and maltose (disaccharide) are formed. When boiled with acid, on the other hand, the hydrolytic cleavage goes further and, although dextrine and maltose occur as intermediary products, yet the final product is monosaccharide.

The most important members of this group are the starches, the dextrines, glycogen, the celluloses, and the gums. They are very widely distributed in vegetables, and constitute a most important class of food-stuffs.

General Characters. They do not form crystals, nor, with few exceptions, are they soluble in cold water. Few possess any sweet taste. As a rule they do not diffuse through parchment and are therefore colloids. Their solutions are optically active. They do not reduce metallic oxides in alkaline solution, they do not form osazones and they cannot be fermented with yeast. Like other colloids, they are precipitated when their solutions are saturated with certain neutral salts, such as ammonium sulphate. They may be sub-divided into three sub-groups, the starches, the dextrines and the celluloses.

1. **The Starches.** These include ordinary starch and glycogen $(C_6H_{10}O_5)_n$. Starch is the most widely distributed carbohydrate in the vegetable kingdom, for it is in this form that plants store up their excess of carbohydrate. Animals store their excess of carbohydrate partly as glycogen, but mainly as fat. If the amount of dextrose produced in the leaves be in excess of the present needs of the plant, it is stored up as starch. These starch grains may be seen in various parts of the plant. They show, under the microscope, concentric markings. In its minute structure the starch granule is

¹ It is impossible to give a definite value to n because the molecular weight is unknown. The symbol n signifies that the formula within the brackets is to be multiplied an indefinite number of times.

thought to be composed of a fine interlacement of acicular crystals, the density of the interlacement varying in different portions of the granule, so as to give the appearance of concentric markings. The outside of the granule has densely packed crystals, so that ferments slowly attack it. By boiling, the crystals absorb water and swell up, so that, after cooling, ferments more readily penetrate and digest the granule.

The exact shape of starch grains varies according to the plant from which they are obtained. In this connection they may be divided into two groups: (1) a group in which the contour of the grains is even, such as wheat, barley, arrowroot, potato; (2) a group in which the contour is marked by facets, either completely, as in oats and rice, or only partially, as in tapioca and sago.

EXPERIMENT I. Examine some wheat flour, a scraping of potato, and some ground rice under the microscope. To do this, mix the flour, etc., with a drop of water on a slide, and examine under a cover slip.

Starch, like most other polysaccharides, is insoluble in cold water, but it swells up in hot water, an opalescent mixture being formed. This is not a true solution, for it does not depress the freezing point of water (*e.g.* has no osmotic pressure, etc.). It is a colloidal solution. Starch does not pass through a dialyser.

EXPERIMENT II. Place some powdered starch in a test tube, and half fill up with cold water—no solution occurs—now boil, when an opalescent mixture will be produced, and, if of sufficient concentration, this will gelatinise on cooling. Try Trommer's test—no reduction occurs.

The standard test for starch is with iodine solution.

EXPERIMENT III. To an opalescent cold solution of starch add a drop or two of a very dilute solution of iodine in potassium iodide: a blue colour results, which disappears on gradual heating and returns again on cooling. Excessive heat must be avoided, since the iodine is volatile.

Starch granules also give this reaction under the microscope. The cut surface of a potato gives it.

Hydrolysis can be effected by boiling with a weak acid or by the action of ferments such as ptyalin, amylopsin, and malt diastase.

EXPERIMENT IV. Place some starch solution in a flask, add to it a few drops of 25% sulphuric acid and boil for about a quarter of an hour. Neutralise and apply the iodine test and note that, instead of a blue, a reddish brown colour is produced (due to dextrine). Apply Trommer's or Fehling's test, and note that reduction occurs.

EXPERIMENT V. Place some of the starch solution in the mouth, and after a minute or so transfer it again to the test tube; now apply Trommer's or Fehling's test—reduction occurs.

Try the same experiment with some unboiled starch, and note that, with Trommer's test, there is no reduction (*i.e.* the resistant external layers have not been hydrolysed).

The sugar produced by hydrolysing with an acid is dextrose, whereas that produced by ferment action is maltose.

Glycogen ($C_6H_{10}O_5$)_n. Just as plants store up excess of carbohydrate in the form of starch, so do animals store it partly in the form of glycogen. The chief seats of this storage are the liver and muscles. Glycogen forms a non-crystalline, white powder, the particles of which have no characteristic appearance under the microscope. It is soluble in water and the solution is opalescent. Solutions of glycogen are dextro-rotatory.

EXPERIMENT VI. A simple method for the preparation of glycogen is that introduced by Fränkel. It consists in grinding up fresh liver or the common shell-fish, mussel, in a mortar with about three times its volume of a 3% solution of tri-chloroacetic acid. This reagent coagulates the proteins. The glycogen is contained in the extract, and can be precipitated by alcohol.¹ After collecting on a filter dissolve some of the glycogen in water and notice that the solution is opalescent. Add to this a drop or two of iodine solution: a port-wine colour results, which disappears on heating, and returns on cooling.

EXPERIMENT VII. Place 5 c.c. of glycogen solution in a test tube and add ordinary alcohol carefully until a precipitate forms. Note approximately how much alcohol requires to be added to obtain this (about 55%).

EXPERIMENT VIII. Try Trommer's test with the glycogen solution; no reduction occurs, but the $Cu(OH)_2$ is held in solution.

EXPERIMENT IX. To some of the solution add a few drops of 25% H_2SO_4 and boil for about ten minutes; dextrose is produced, as can be shown by applying one of the reduction tests.

EXPERIMENT X. Mix some glycogen solution with saliva and place the test tube in water at body temperature. After about ten minutes apply one of the reduction tests. It will be found that a reducing sugar has been produced.

The Dextrines ($C_6H_{10}O_5$)_n. During the hydrolysis of starch and glycogen dextrines are formed as an intermediate product. British

¹ Where not otherwise specified in these experiments, alcohol refers to the commercial product containing from 92-96% pure alcohol.

gum is dextrine produced by heating starch to 200° C. This substance is much employed as the adhesive substance on stamps and envelopes. There are several varieties of dextrine, varying from one another in molecular weight. The highest dextrine is called amylo-dextrine, the next erythro-dextrine, then achroödextrine.

Dextrine is an amorphous powder, soluble in cold water, and forming a *clear* solution with which the following reactions can be obtained :

EXPERIMENT XI. Add some iodine solution ; a brownish red colour, like that obtained with glycogen, results, which disappears on heating and returns on cooling. It is only one form of dextrine—erythro-dextrine—which gives the reaction ; achroödextrine gives no reaction with iodine. The bluish tint sometimes obtained is due to the presence of starch.

EXPERIMENT XII. Try Trommer's test : no reduction is obtained, but $\text{Cu}(\text{OH})_2$ is held in solution.

EXPERIMENT XIII. Hydrolyse some dextrine solution and then apply Trommer's test : reduction occurs.

The Quantitative Estimation of Glycogen in Animal Tissues.

The importance of a rapid and accurate determination of the amount of glycogen in animal tissues has led to the publication of many different methods. To within a few years ago, however, none of these has been of sufficient accuracy, the difficulty being to separate the glycogen from protein without losing any of the glycogen. It is to Pflüger that we owe a method which is unquestionably far superior to any of its predecessors. This method depends on two facts : firstly, that glycogen is not affected by heating it on a water bath with thirty per cent. potassium hydroxide solution, whereas protein under such conditions is destroyed ; and secondly, that by the addition of an equal volume of water to the above solution (which will bring the percentage of potassium hydroxide to fifteen) and the subsequent addition of two volumes of alcohol (96%) all the glycogen is precipitated, whereas practically all of the degradation products of protein remain in solution. The method is as follows¹ :

The liver is cut into small pieces and mixed in an Erlenmeyer flask (Bohemian glass) with 100 c.c. 60% KOH.²

¹The following description is for 100 gr. liver, but much less than this amount is sufficient for most purposes. Thus, in the case of a dog, fed on the previous day with bread and meat, 20 gr. liver is a suitable amount, and in the case of a rabbit fed with carrots or other-carbohydrate-rich food, 10 gr. is sufficient. In the case of muscle, it is best to take 100 gr., as the percentage of glycogen in this tissue is practically never more than one.

²Pflüger specifies 'Merck A' KOH, but for most purposes 'KOH pure by alcohol' is of sufficient purity. The strength is best adjusted by the use of a hydrometer (alkalimeter), the specific gravity of such a solution being 1.438 at 15° C. or 44 on the Baumé scale.

The flask is closed with a cork, having a wide glass tube about five feet long passing through it to serve as a reflux condenser, and it is then immersed in a boiling water bath and left there for three hours, with occasional shaking. (Less time than this suffices to completely destroy the protein of liver.) On removal from the water bath, the contents of the flask are allowed to cool, and are then thoroughly shaken, with 200 c.c. water (thus bringing the percentage of KOH to fifteen). 800 c.c. of ordinary (96%) alcohol are then added to the solution, the mixture shaken and allowed to stand for several hours (preferably overnight).

The more or less white precipitate of glycogen will by this time have settled down, so that the supernatant reddish fluid can with care be poured off into a beaker, after which it is filtered through a filter paper of suitable size, so as to collect on the filter any particles of glycogen which the decanted fluid may contain. The precipitate of glycogen is now thoroughly shaken with about ten times its volume of 66% alcohol (about 700 c.c. alcohol and 300 c.c. water) containing 1 c.c. per litre of a saturated solution of NaCl. This washing fluid removes many of the impurities which adhere to the glycogen.

After settling, the wash fluid is decanted into the same beaker as was employed for receiving the original supernatant fluid, and filtered through the same filter. This process is repeated at least once again, after which the precipitate is shaken with ordinary alcohol (about 10 times its volume), and the suspension thrown on to the same filter paper as used above.

When the alcohol has all drained off, the precipitate is washed on the filter paper with ether. All the washed glycogen has thus been collected on the filter paper and must now be dissolved, for which purpose the filter is filled up with boiling water, and the solution of glycogen allowed to filter through into a clean Erlenmeyer flask. When the first added water has completely drained through the filter, the filter is filled up with boiling water a second and a third time. It is essential to allow the filter to drain completely before adding more water. To be certain that all the glycogen has been dissolved, some of the final filtrate should be tested with alcohol for glycogen.

The resulting opalescent solution can now be employed either for the preparation of pure glycogen or for its quantitative estimation. For the former purpose the glycogen is precipitated by alcohol; for the latter purpose the glycogen solution is made up to a litre in volume, and of this 200 c.c. are taken, mixed with 10 c.c. HCl (conc.) (*i.e.* 5 c.c. HCl to a 100 c.c. of glycogen solution), and heated in a flask on the water bath for three hours.¹ Complete hydrolysis of the glycogen is certain within this time, although the resulting solution often contains a flocculent precipitate which is probably of some protein body. The solution, after cooling, is neutralised with 20% KOH and filtered into a 250 c.c. measuring flask through a small filter (10 cm.) paper.

The flask used for inversion is rinsed three times with distilled water, the washings being each time poured on to the filter and added to the contents of the measuring flask. In this way the volume of the dextrose solution is brought exactly to 250 c.c.

Where only 10 or 20 gr. of liver were originally employed, the above measurements must of course be altered, it being usually best to take all of

¹ If the glycogen be reprecipitated and redissolved in a known volume of water the resulting solution can be examined in the polarimeter and its glycogen content calculated according to the formula on p. 284. (α) $D = 196 \cdot 63$.

the glycogen solution for inversion and bring it to a definite volume after neutralising.

For the estimation of the dextrose formed Pflüger uses a special gravimetric method (*see Dictionnaire de physiologie*, par C. Richet, t. vii.), but Bang's method, described in the following section, is of sufficient accuracy for most purposes.

Quantitative Estimation of Sugars.

All the methods employed for this purpose consist in determining the reduction brought about by a measured amount of sugar solution in a known alkaline solution of cupric salts. They may be divided into two classes :

(i) Methods in which sugar solution is added to a measured volume of the cupric salt employed, until the reduction to cuprous salt or oxide is complete. To this class belong the methods of Fehling, Pavy and Gerrard, which are described in Chapter XX. For the estimation of sugar in urine they are usually of sufficient accuracy, and are widely employed for this purpose. Their great advantage is simplicity.

(ii) Methods in which excess of cupric salt is employed. In Pflüger's method the precipitated cuprous oxide is weighed. In Bang's method the excess of cupric salt is determined by titration. In both these methods it is possible to keep the conditions of different titrations exactly similar except as to the excess of cupric salt employed, which will naturally depend on the amount of cupric salt reduced by the sugar in the determination. Now it is found that the larger the excess of cupric salt present the greater is the reduction caused by a given amount of sugar. The reduction is therefore not proportional to the amount of sugar employed in the determination, and it is necessary to construct a table, representing the amount of reduction caused by different known amounts of sugar, from which the results of any given determination can be calculated. These methods are more accurate than those of the first class.

EXPERIMENT. Bang's Method.

Principle.—In the presence of carbonates and sulphocyanides cuprous oxide forms cuprous sulphocyanide, which becomes dissolved to form a colourless solution in the presence of excess of potassium sulphocyanide. A solution of cupric carbonates containing potassium sulphocyanide is boiled for exactly three minutes with an amount of the sugar solution, which is insufficient to reduce all the cupric salt; after rapidly cooling, the amount of cupric salt which has not been reduced by the sugar is then determined by titration in the cold with a standard solution of hydroxylamin (sulphate). This, like sugar, reduces cupric salts to the cuprous state to form, as above explained, a colourless solution. The hydroxylamin solution must not be run in too quickly, else a precipitate forms and the results are vitiated. Shake sufficiently to prevent the precipitate forming. At least 30 seconds should be taken in titrating. The hydroxylamin solution is of such a strength that 1 c.c. of it exactly decolourises 1 c.c. of the copper solution. From the amount of hydroxylamin solution required to reach the decolourisation point, the sugar content is obtained by using tables which have been constructed for this purpose.

Preparation of Solutions. Solution I.—12.5 gr. CuSO_4 (purified as directed in the footnote¹) are dissolved by heat in 75 c.c. water and the solution cooled to 25° C. In a large porcelain basin 250.0 gr. potassium carbonate, 200.0 gr. potassium sulphocyanide and 50.0 gr. potassium bicarbonate are dissolved by stirring in 600 c.c. water. During the process of solution of these salts the temperature at first rises and then falls. If the potassium bicarbonate does not become dissolved the basin must be placed on a water bath and the temperature raised to 40° C. (but no higher). The solution is then cooled to 15° C. and the copper solution mixed with it in small quantities at a time with frequent shaking, so as to prevent any large amount of precipitate forming. The solution is then made up to 1 litre in volume.

Solution II.—6.55 gr. hydroxylamin sulphate or 5.56 gr. hydroxylamin chloride² is dissolved in water and the solution added to one of 200 gr. potassium sulphocyanide in 1500 c.c. water. The volume is then brought up at 2000 c.c.

Titration.—The amount of sugar added must be less than 0.06 gr. (to which limit the table has been constructed). If, therefore, the solution to be examined contain less than 0.6 per cent., 10 c.c. of it are taken for the estimation; if it contain more, then such a number of c.c. must be taken as will yield a total amount less than 0.06 gr. In all cases the sugar solution must be made up to 10 c.c.³

Mix the 10 c.c. sugar solution with 50 c.c. of the copper solution in an Erlenmeyer flask. Place on wire gauze over a Bunsen burner and bring to the boil. Maintain the boiling for exactly three minutes. Cool the solution quickly by holding the flask under the cold water tap. Place under a burette containing the hydroxylamin solution, and add this, with constant shaking of the flask until the blue colour is just discharged.

The weight of dextrose corresponding to the amount of hydroxylamin solution used is then read off on the following table. (See p. 295.)

Pentoses.

Besides the hexoses, animal tissues also contain small amounts of pentoses, that is, sugars containing five carbon atoms, $\text{C}_5\text{H}_{10}\text{O}_5$. Being aldehydic in nature, they possess reducing powers and form osazone crystals. They do not ferment with pure yeast, but they all rotate the plane of polarised light. In the animal tissues pentoses do not exist in a free state, being, as far as is known, bound to guanylic acid (see p. 310). They are very plentiful in plants, where they

¹ Filter a hot saturated solution of copper sulphate into a large evaporating dish, and after covering with a sheet of filtered paper allow to stand for some hours. Collect the crystals which separate out on a filter, and after all the mother liquor has drained, open up the filter and spread out the crystals between several folds of filter paper. Press then between the folds of filter paper, removing them to fresh paper, until perfectly dry. This is ascertained by placing a glass rod on the crystals and then tapping it. If dry no crystals will stick to the rod.

² The sulphate is recommended by Bang, but we have found the chloride quite as suitable.

³ Where there is no previous knowledge as to the strength of the sugar solution a preliminary titration should be made by boiling 10 c.c. of the solution with 50 c.c. of the copper solution for three minutes. If the blue colour disappears, repeat with 5 c.c., and so on until the amount is found which does not discharge the blue.

TABLE FOR CALCULATION OF AMOUNT OF DEXTROSE FROM HYDROXYLAMIN SOLUTION USED IN BANG'S METHOD.

Hydroxy-lamin solution. c.c.	Dextrose. mg.	Hydroxy-lamin solution. c.c.	Dextrose. mg.	Hydroxy-lamin solution. c.c.	Dextrose. mg.	Hydroxy-lamin solution. c.c.	Dextrose. mg.
43·85	5	29·60	19	17·75	33	7·65	47
42·75	6	28·65	20	16·95	34	7·05	48
41·65	7	27·75	21	16·15	35	6·50	49
40·60	8	26·85	22	15·35	36	5·90	50
39·50	9	26·00	23	14·60	37	5·35	51
38·40	10	25·10	24	13·80	38	4·75	52
37·40	11	24·20	25	13·05	39	4·20	53
36·40	12	23·40	26	12·30	40	3·60	54
35·40	13	22·60	27	11·60	41	3·05	55
34·40	14	21·75	28	10·90	42	2·60	56
33·40	15	21·00	29	10·20	43	2·15	57
32·45	16	20·15	30	9·50	44	1·65	58
31·50	17	19·35	31	8·80	45	1·20	59
30·55	18	18·55	32	8·20	46	0·75	60

exist as polysaccharides called *pentosanes*. Thus, in gum arabic there is a pentosane which yields *l*-arabinose when hydrolysed by heating with mineral acid, and in wood or bran another pentosane yields *l*-xylose on similar treatment, which is the variety of pentose present in the nucleic acid of animal cells. Pentose sometimes occurs in the urine—the condition being called pentosuria—the variety being racemic arabinose (inactive optically). From what source this is derived is difficult to determine, for it is independent of the pentoses in the food, and its structure is different from that found present in the tissues. It is mostly combined with urea.

EXPERIMENT. Hydrolyse gum arabic by heating a solution of it in a water bath for twenty minutes with 5% HCl. Arabinose is formed. After neutralising, apply reduction and yeast fermentation tests to portions of the solution. To another portion apply the following characteristic test for pentoses (Tollens). Add phloroglucin ($C_6H_3(OH)_3$) in small quantities at a time till no more dissolves to a solution of about 5 c.c. of equal parts of concentrated HCl and water. Then add a few drops of the arabinose solution and warm until a red colour develops. Examine with the direct vision spectroscope when an absorption band will be seen between D. and E. lines. By further heating, a precipitate forms which becomes dissolved in amyl alcohol when this is shaken with the solution. The amyl alcoholic solution shows the above spectrum very clearly. Tollens' test can be applied to urine. Repeat this test, using dextrose solution.

EXPERIMENT. Heat about 5 c.c. of Bial's reagent (500 c.c. HCl, sp. gr. 1·151, 1 grm. orcinol, 25 drops 10% ferric chloride solution) to boiling in a test tube, and run in not more than 1 c.c. of the pentose-containing solution, and again heat just to boiling point. A greenish-blue colour rapidly develops. This colour can be extracted with amyl alcohol, when it shows an absorption band in the red.

Repeat this test, using a dilute solution of dextrose instead of pentose, when practically no colour change will occur.

TABLE OF CHARACTERISTIC REACTIONS OF CARBOHYDRATES.
I. MONOSACCHARIDES AND DISACCHARIDES.

Sugar.	Reducing power (compared with that of dextrose).	Effect of hydrolysis on reducing power.	Rotatory power on polarized light. (α)D.	Effect of hydrolysis on rotatory power.	Fermentation with yeast.	Ossazone crystals (melting point).	Solubility in absolute alcohol. ¹	Special tests.
Dextrose.	Marked.	None.	+52.7.	None.	Marked.	Long thin needles, 204° C.	Soluble -.	—
Laevulose.	Same as dextrose.	None.	-93.	None.	Marked.	Same.	Soluble +.	Seliwanoff's test.
Galactose.	Same as dextrose.	None.	+81.	None.	Very slowly.	Melting point about 186° C.	—	Mucic acid on heating with HNO ₃ .
Maltose.	33% weaker. ²	Increases.	+137.04.	Decreases.	Marked.	Shorter thicker needles, 206° C.	Slightly soluble.	—
Lactose.	26.5% weaker.	Increases.	+52.5.	Increases.	None.	Mass of needles very compact, 200° C.	Insoluble.	Forms mucic acid on heating with HNO ₃ .
Cane Sugar.	No reducing power.	Becomes same as dextrose. ³	+66.54.	Becomes -20.2°.	Marked.	None (if hydrolysis prevented).	Soluble.	Seliwanoff's test.

POLYSACCHARIDES.

Polysaccharide.	Solubility in water.	Appearance of solution.	Solubility in alcohol.	Reaction to Iodine.	Special tests.	Special rotatory power. (α)D.
Starch.	Soluble with heat.	Opalescent.	Insoluble.	Blue.	Microscopic.	+202° for 2.5-4.5% solutions.
Glycogen.	Soluble in cold.	Opalescent.	Precipitated by 55% alcohol.	Reddish brown.	Precipitated by basic lead acetate.	+196.63.
Erythro-dextrine.	Soluble in cold.	Clear.	Precipitated by 85% alcohol.	Reddish brown.	Not precipitated by basic lead acetate.	+195 (about).
Achroo-dextrine.	Soluble in cold.	Clear.	Requires more than 85% alcohol to precipitate.	No reaction.	—	—

¹None of the sugars are more than slightly soluble in absolute alcohol. Cane sugar is fairly soluble. In the above table the solubility of cane sugar is taken as the standard, the minus sign indicating less solubility, the plus sign more solubility than this.

²These percentages are only approximate. For the exact relative reducing powers of the various sugars tables such as those of Kjeldahl must be used. 10 c.c. of Fehling's solution is reduced by 0.060 grm. dextrose or laevulose, 0.0676 grm. lactose, 0.074 grm. maltose, 0.0475 grm. cane sugar (after inversion by acid). 0.475 grm. cane sugar, when inverted, has the same reducing power as 50 grm. dextrose.

CHAPTER IV.

THE PROTEINS.

THIS group of bodies, as their name signifies (protos = first) are bodies of great importance. They occur in all animal and vegetable cells; indeed they are intimately connected with the life of the cell. Without them as food-stuffs animal cells cannot live. At present, too, they are bodies of purely biological origin, no effort to make them in the laboratory having as yet been successful. Most of the members of the group are amorphous bodies of high molecular weight. The molecule is made up of the elements carbon, hydrogen, nitrogen, oxygen, and sulphur. The amounts of the elements vary considerably in different proteins, as can be seen from the following table:—

Protein.	C.	H.	N.	O.	S.
Fibrinogen,	52·93	6·90	16·66	22·26	1·25
Serum albumin,	52·08	7·10	15·93	21·96	1·90
Serum globulin,	52·71	7·01	15·85	23·32	1·11
Keratin, - .	50·65	6·36	17·14	20·85	5·00
Elastin,	54·32	6·99	16·75	21·94	—
Gelatin, - .	49·83	6·80	17·97	25·13	0·7

The nitrogen and the sulphur are usually contained in two forms, loosely combined and firmly combined. The loosely combined portions can be split off from the molecule by boiling with a caustic alkali (caustic soda, caustic potash, or soda lime).

All proteins when heated alone give a smell of burnt feathers, due to the evolution of ammonia, pyridine, etc.

EXPERIMENT I. Evaporate to dryness some of the protein solution provided. Heat strongly. Notice the charring and smell of burnt feathers.

EXPERIMENT II. **The loosely combined Nitrogen.**—To about five c.c. of diluted egg-white add a few drops of 20 % caustic soda; warm slowly, and hold a piece of moistened red litmus paper over the mouth of the test tube. The litmus turns blue, showing that ammonia gas is being evolved. The ammonia may also be detected by its smell, or by holding the stopper of the concentrated hydrochloric acid bottle over the mouth of the test tube when fumes of ammonium chloride are formed.

EXPERIMENT III. **The loosely combined Sulphur** (lead sulphide test).—To about five c.c. of 20 % caustic soda add two drops of lead acetate solution and some solution of egg-white. Boil. A brown to black colour is developed, due to the lead sulphide which is formed.

Recent research has shown that nitrogen may be detected in the protein molecule after complete hydrolysis with 30 % sulphuric acid as :—

(1) *Amide or Ammonia Nitrogen*. This is the loosely combined nitrogen mentioned above.

(2) *Diamino Nitrogen*, precipitated by phosphotungstic acid after the amide N has been removed.

(3) *Monamino Nitrogen* estimated in the residuum when the above two have been removed.

By this means the difference in composition of proteins is further brought out :—

	Total N.	Amide N.	Diamino N.	Monamino N.
Caseinogen, - - -	15·62	1·61	3·49	10·31
Edestin (from hemp),	18·64	1·88	5·91	10·78
Gliadin (from wheat),	17·66	4·20	·98	12·41
Glutenin (from wheat),	17·49	3·30	2·05	11·95
Zein (from maize),	16·13	2·97	·49	12·51

(T. B. Osborne.)

The complex constitution has been studied recently in two ways—(1) by working out the products of hydrolysis (breaking down) of the different proteins; (2) by endeavouring to link together simple cleavage products, and thereby produce some form of protein. As the result of the first method of procedure, we now know that the proteins of the various parts of the body differ greatly in composition; for example, the protein of the spleen is different from that of the thymus or of the pancreas. Further, the protein of the same tissue differs in animals of different species, *e.g.* the serum albumin of the blood of one animal has a different constitution to the serum albumin of an animal of another species; likewise, the chief protein (caseinogen) of milk. We can understand, therefore, why it is that the proteins of the food have to be broken down into such numerous end products in the digestive tract. From these end products chiefly those are required which are of value in building up the animal's own particular forms of protein, forms, as we have seen, differing in various parts of the body, and wholly different from the protein ingested. It is only, therefore, by very complete hydrolysis, that these valuable end products can be obtained free from products of lesser value. (See also under Digestion.)

In the following table will be seen the varying yields of the different amino acids obtained from 100 parts of various proteins, after complete hydrolysis with hydrochloric or sulphuric acid. Tyrosin and cystin are separated by crystallisation, after neutralising and concentrating the liquid. The diamino acids—arginin, histidin, lysin—are separated from the rest of the products by being precipitated by phosphotungstic acid in acid solution. Tryptophan is separated by precipitation with mercuric sulphate in the presence of 5 % sulphuric acid after tryptic digestion. The other amino acids are separated (after hydrolysis of

the protein with hydrochloric acid) by fractional distillation of their ethereal salts under greatly reduced pressure. It will be noticed that the figures given for any one protein do not by any means add up to 100%. This is due to the occurrence of some inevitable loss in the method of separation, and to the fact that doubtless all the components of protein have not yet been isolated.

End products.	Serum Albumin.	Egg Albumin.	Serum Globulin.	Caseinogen (cow).	Fibrinogen.	Edestin.	Keratin.	Gelatin.	Elastin.
Glycin, - -	0	0	3.5	0	3.0	3.8	4	16.5	25.8
Alanin, - -	2.7	2.1	2.2	.9	3.6	3.6	1.2	.8	6.6
Leucin, - -	20.0	6.1	18.7	10.5	15.0	20.9	18.3	2.1	21.4
Aspartic acid,	3.1	1.5	2.5	1.2	2.0	4.5	2.5	.6	+
Glutamic acid, -	7.7	8.0	8.5	11.0	8.0	6.3	3.0	.9	.8
Cystin, - -	2.3	.2	.7	.1	—	.3	+	—	—
Histidin,	—	—	—	2.6	—	1.1	—	—	—
Lysin, - -	—	—	—	5.8	—	1.0	—	28	—
Arginin,	—	—	—	4.8	—	1.7	2.3	7.6	.3
Phenyl-alanin,	3.1	4.4	3.8	3.2	2.0	2.4	3.0	.4	3.9
Tyrosin, - -	2.1	1.1	2.5	4.5	3.5	2.1	4.6	0	.3
Tryptophan, -	+	+	+	1.5	+	+	0	0	—
Other amino acids,	3.1	2.3	2.8	5.3	5.4	4.1	10	9.6	2.7

The results of the synthetic method of procedure have also been highly interesting. This has been mainly the work of Emil Fischer and his pupils. Starting with a simple end product, such as glycin, monamino-acetic acid, two of these are combined together, forming a *di*-peptide glycyl-glycin with the elimination of water, thus:—

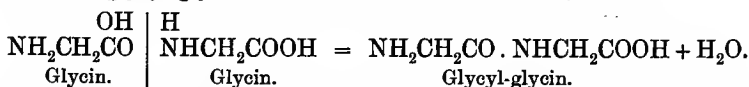

The addition of another molecule forms a *tripeptide*, and so on until *polypeptides* (*many* linkages) are formed. Pentaglycyl-glycin, for example, is:—



But not only has glycin been combined to glycin—other end products, such as alanin, leucin, phenylalanin, tyrosin, etc., have been combined together, giving such bodies as leucyl-glycyl-alanin, and so on. For example, the polypeptide (*do*-deka-peptide) leucyl-deca-glycyl-glycin has the formula:—



By many such operations, polypeptides have been obtained, which, if

not actually having the same composition as any known peptone (see later), have many resemblances to peptones.

The proteins have for the most part many physical and chemical reactions in common.

THE PHYSICAL AND CHEMICAL PROPERTIES OF PROTEINS.

I. Solubility.—All proteins¹ are insoluble in alcohol and ether. They vary as to their solubility in water, the more common proteins (albumins and globulins) being soluble in water (albumins) or in weak saline solutions (globulins). Some, however, are not soluble, even in concentrated saline solutions.

EXPERIMENT IV. From the undiluted egg-white provided prepare a solution of egg albumin by adding 10 volumes of distilled water and mixing thoroughly in a flask. An opalescent solution is thus obtained, the opalescence being partly due to the colloidal nature of the solution, although in part to some other protein (ovo-mucin), which has not gone into solution. This can be removed by filtering through fine muslin. Note that this solution, like all colloidal solutions, *gives a persistent froth on shaking.*

The solution prepared above can be used in the subsequent experiments, unless otherwise stated.

II. Diffusibility.—As the proteins give only *colloidal solutions*, these solutions will not dialyse, that is, diffuse through animal membranes or parchment paper. In this they are unlike *crystalloids*, such as inorganic salts, which readily diffuse through such membranes. Of the various forms of dialyser, a tube of parchment is the simplest.

EXPERIMENT V. Place a mixture of diluted blood and of a 10% sodium chloride solution in the dialyser provided. Test a sample of distilled water with silver nitrate, and note that no haze of silver chloride occurs. Place the dialyser in a beaker of this water and allow dialysis to proceed for a day. On now testing the water in the beaker for chlorides with silver nitrate, it will be found that a white precipitate of silver chloride occurs, showing that the chlorides have diffused through the parchment. It can be shown, however, that no protein has dialysed through, *by the absence of pigment* and by applying the tests for protein given below.

III. Heat Coagulation.—Most of the so-called native proteins (albumins and globulins) coagulate when their solutions are heated. Different proteins coagulate at different temperatures, varying usually from 56°C.–78°C. A faint degree of acidity and the presence of much neutral salt greatly favour heat coagulation.

¹ Some vegetable proteins are soluble in alcohol.

EXPERIMENT VI. Fill a narrow glass tube with some egg-white solution, faintly acidulated with acetic acid, and fasten off one end. Now fix this to the lower end of the thermometer by means of small elastic bands. Gradually heat in a test tube placed in a water bath and observe the temperature at which the albumin becomes opaque and set.

IV. **Crystallisation.**—Most proteins crystallise with difficulty; the blood pigment of certain animals, however, crystallises readily. (See later under Blood, Chapter VIII.) Egg albumin and serum albumin

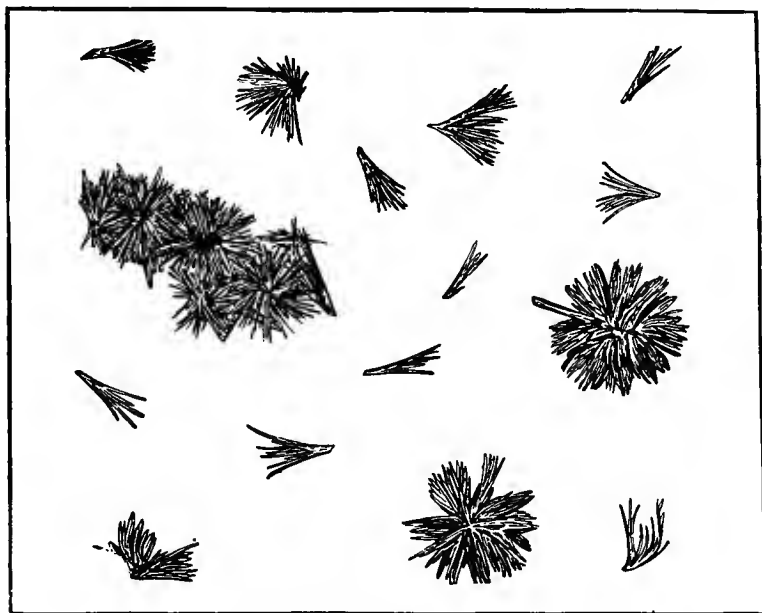

FIG. 224.—Crystallised albumin. $\times 600$.

have, however, been crystallised. Certain vegetable proteins, *e.g.* the globulin of hemp seed (edestin), crystallise more easily.

DEMONSTRATION. Some hemp seed has been thoroughly pounded, extracted with warm 5 % sodium chloride (50°C .) and placed in a dialyser overnight. As the result of dialysis, crystals of edestin have become deposited in the tube. Examine those placed under the microscope. Crystals of edestin may also be obtained, on standing, by cooling with ice the extract of hemp seed.

To obtain crystals of egg albumin the whites of several eggs are mixed with an exactly equal amount of a fully saturated solution of ammonium sulphate. This precipitates the globulins. The ammonium sulphate solution must be exactly neutral in reaction and should be added to the egg-white in small quantities at a

time, the mixture being briskly stirred between each addition. The precipitated globulin is filtered off, and the filtrate, which reacts alkaline to litmus, is treated with ammonium sulphate, drop by drop, until a faint haze of precipitated albumin is obtained. A drop of water is added, so that the haze just disappears. The solution is now treated with 10% acetic acid, drop by drop, until a precipitate of albumin just forms. The flask is set aside; in about twenty hours it will be found that a large number of needle-shaped crystals have become deposited (see Fig. 224).

V. Rotation of Light.—All proteins are laevo-rotatory. Some combined proteins, such as haemoglobin and nucleo-protein, are dextro-rotatory, but their protein portion is laevo-rotatory.

VI. Colour Reactions. This group of reactions is very important, as each reaction yields information as to the constitution of the protein molecule. The meaning of each test should therefore be carefully noted.

(a) **The Biuret Reaction (Piotrowski's test).**

EXPERIMENT VII. Pour a drop of weak copper sulphate into a test tube. Now add some 20% caustic soda until a pale blue colour is obtained (about 15 c.c.). Divide this into three portions, A, B, C. Keep A as control colour. To B add a few drops of diluted egg-white. To C add the same number of drops of the commercial peptone provided. Note the *violet* colour with albumin, the *pink* colour with the peptone solution.

It is important to keep control tube A, since in using very weak solutions a slight change in colour can be detected by comparison with the control.

All proteins give either a purple or pink colour with this test. It shows that the protein contains two or more CO-NH- groups linked together. The same reaction is given by the body biuret formed when urea is heated, hence the name.

(b) **Xanthoproteic Reaction.**

EXPERIMENT VIII. To about 5 c.c. of the solution of egg-white add a few drops of strong nitric acid; a white precipitate results. Warm this and the precipitate changes to a yellow curd. Cool under the tap. Add a few drops of strong ammonia; the yellow colour changes to a brilliant orange. The name xanthoproteic (*yellow* protein) will help the student to remember the colour of the curd obtained. This test shows the presence of the benzene ring in the protein molecule; hence only proteins containing such a ring give this test.

(c) **Millon's Reaction.**

EXPERIMENT IX. Add a few drops of Millon's reagent (which consists of a solution of mercurous and mercuric nitrates) to some of

the egg-white solution. A white coagulum occurs, which on warming changes to a brick-red curd.

This reaction differs from the xanthoproteic only in depending upon the presence of the benzene ring with an hydroxyl group attached to it in addition, or, in other words, the phenolic group.

(d) **The Glyoxylic Acid test** (Hopkins' modification of Adamkiewicz's Reaction).

EXPERIMENT X. To some egg-white solution in a test tube add about 1 c.c. of glyoxylic acid solution, and run in carefully without mixing ordinary strong sulphuric acid. A violet ring is obtained at the junction of the fluid, which extends into the supernatant egg-white solution when the tube is gently agitated.

This test depends upon the presence of tryptophan (indol amino-propionic acid) in the protein molecule, and is only given by proteins containing such a grouping.

(e) **The α -Naphthol test** (Molisch's test).

This has already been given under carbohydrates (*q.v.*). Proteins containing a carbohydrate moiety yield this test. The purple colour should be very pronounced before the test is deemed positive. The green colour obtained plays no part in the reaction. The test is not very reliable.

VII. Precipitation by Neutral Salts ("Salting out").

(A) Ammonium Sulphate.

EXPERIMENT XI. To some egg-white solution add an *equal* amount of saturated solution of ammonium sulphate = *half saturation*. A white precipitate of globulin is produced. Filter; keep the filtrate. After washing the residue with saturated ammonium sulphate dissolve it in a little water and boil. Note that the protein is coagulated in fine flakes. Divide the filtrate:

(a) Add crystals of Am_2SO_4 in excess (*full saturation*). The albumin is now salted out.

(b) Boil; flakes of coagulated protein show the presence of coagulable protein (albumin). Half saturation with Am_2SO_4 therefore precipitates globulins; full saturation precipitates albumins.

(B) Magnesium Sulphate.

EXPERIMENT XII. *Fully saturate* (*i.e.* add crystals) the solution of egg-white with MgSO_4 . A precipitate of globulin results. Filter. Prove by heat coagulation and by fully saturating with Am_2SO_4 that protein (albumin) is left in the filtrate. Magnesium sulphate in full saturation precipitates globulins, but not albumins (see table, p. 312).

(C) *Sodium Chloride, Ammonium Chloride.* These salts resemble magnesium sulphate in their "salting out" properties.

(D) *Sodium Sulphate* possesses at 30° C. the same protein precipitating powers as ammonium sulphate. It is of great advantage when it is desired to estimate the amount of protein in any fluid. By precipitating with sodium sulphate and determining the total nitrogen in the precipitate by Kjeldahl's method (see Urine) the amount of protein is found by multiplying by 6.25.

(E) *Zinc Sulphate* has also been used for salting-out purposes.

VIII. **Coagulants of Proteins.**—A coagulum differs from a precipitate in that it is no longer soluble in its original solvent; in other words, its physical or chemical nature has undergone some change. Such is the case in the coagulation of protein by heat. Other coagulants of protein are:—mechanical agitation, mineral acids and salts, and other acids such as tannic, picric, etc.

EXPERIMENT XIII. Violently shake some egg-white solution with sand. Strings of coagulated protein are deposited.

EXPERIMENT XIV. To some egg-white solution add gently some strong HNO_3 . A white precipitate appears, which is insoluble on heating (cf. Proteoses).

EXPERIMENT XV. Acidulate some egg-white solution strongly with acetic acid, then add strong potassium ferrocyanide—a whitish yellow precipitate.

EXPERIMENT XVI. Add picric acid—a white precipitate. Many other acids, such as phosphomolybdic, phosphotungstic, trichloroacetic and salicyl sulphonic are used to precipitate proteins.

Alcohol precipitates all proteins. At first it forms a precipitate; but if the action be prolonged this changes to a coagulum. Peptone and fibrin ferment (thrombin) take longer to undergo this change; advantage is taken of this to separate these bodies from other proteins (see Preparation of Fibrin Ferment, 336).

CHAPTER V.

PROTEINS—CONTINUED.

THE CLASSIFICATION OF PROTEINS.

THE following classification has now been adopted for proteins. It is based partly upon the results of chemical investigation, partly upon such properties as solubility, "salting out," etc. It cannot, therefore, be regarded as complete.

- | | |
|------------------------|----------------------|
| (1) Protamines. | (2) Histones. |
| (3) Albumins. | (4) Globulins. |
| (5) Phospho-proteins. | (6) Sclero-proteins. |
| (7) Compound proteins. | |

The Protamines.—These substances are the simplest proteins known (Kossel). They occur combined with nucleic acid in the spermatozoa of certain fishes, such as the salmon, sturgeon, mackerel and herring. *Sturin* from the sturgeon has the formula $C_{36}H_{69}N_{19}O_7$; *salmin* (salmon) and *clupein* (herring) have the formula $C_{36}H_{57}N_{17}O_6$. They are difficult to obtain in a state of purity, and the technique is complicated. Upon hydrolysis they yield large amounts of the hexone bases arginin, lysin, histidin, especially arginin.

Monamino acids are combined into the protamines, but only one *cyclopterin* has so far yielded a ringed amino acid grouping.

The protein nature of the protamines is shown by the fact that *they yield the Biuret test.*

The Histones occur mainly in combination. Perhaps the best known example is the *globin* portion of haemoglobin. They also occur combined in the nuclei of blood corpuscles, *e.g.* in the red corpuscles of the goose and in the white corpuscles of the thymus gland.

The histones are somewhat more complicated than the protamines. Bang gives the following characteristic reactions:—

- (a) They are precipitated from watery solution by ammonia—the precipitate being soluble in excess.
- (b) In presence of salts they are coagulable by heat.
- (c) They give a precipitate with nitric acid in the cold, soluble on heating, reappearing on cooling (*cf.* Proteoses and Peptones).

THE ALBUMINS AND GLOBULINS.

These two groups have been already studied in the preceding experiments with the egg-white solution. The main difference between the albumins and the globulins is that of solubility. It has also been shown chemically that the products of hydrolysis differ, the albumins yielding no glycin. Upon hydrolysis all yield members of the chief amino acid groups (see table, p. 299).

Albumins are soluble in distilled water and in saturated solutions of all neutral salts except ammonium sulphate and anhydrous sodium sulphate, in which they are insoluble. They are, however, soluble in half-saturated solutions of these salts (see table, p. 312).

Globulins are insoluble in distilled water and in saturated solutions of all neutral salts. They are, moreover, insoluble in half-saturated

solutions of ammonium sulphate and anhydrous sodium sulphate. They are soluble in weak saline solutions (see table, p. 312).

The chief kinds of albumins are egg albumin, serum albumin (see Blood), and lactalbumin (see Milk).

The most important globulins are egg globulin, serum globulin, fibrinogen (for both see Blood), and myosinogen (see Muscle).

THE PHOSPHOPROTEINS.

The chief members of this group are the caseinogens of milk and the vitellins from egg-yolk. They derive their name from the large amount of phosphorus contained in their molecule. They differ, however, from nucleoproteins in containing *no* purin bases.

Dissolve some commercial caseinogen in 2 % caustic soda, and perform the following EXPERIMENTS :—

- (I.) Note that it is precipitated with 1 % acetic acid, the precipitate being soluble in excess of acid.
- (II.) Perform the colour tests for protein, and record your results.
- (III.) Perform the "salting out" tests with Am_2SO_4 and MgSO_4 .
- (IV.) Heat the solution.

With the solid substance perform the following experiments :—

- (V.) Heat some solid caseinogen upon a piece of broken porcelain with "combustion mixture" (a mixture of sodium carbonate and potassium nitrate). When cool, extract with nitric acid, filter, add ammonium molybdate in nitric acid, and heat. The canary yellow precipitate denotes phosphates.
- (VI.) Heat a little caseinogen with 1 % NaOH in the incubator or on a water bath at 37° C. for twenty-four hours. Phosphoric acid is broken off. Precipitate the phosphoric acid, after acidifying with acetic acid and filtering, by the addition of ammoniacal magnesium citrate. Filter. Dissolve the precipitate in nitric acid, and test with molybdate as above.
- (VII.) Make a solution of caseinogen in lime water. Show that it is clotted by rennet.

In connection with the above experiments it will be found that caseinogen yields all the colour tests except Molisch. It therefore contains no carbohydrate group (see p. 279). The xanthoproteic, Millon's, and the glyoxylic tests will be very well marked, showing that caseinogen is rich in tyrosin and tryptophane.

In "salting out" caseinogen behaves like a globulin, being pre-

cipitated by full saturation with magnesium sulphate and half saturation of ammonium sulphate.

Caseinogen is *not* coagulated by heat (see table, p. 312).

THE SCLERO-PROTEINS.

This comprises the group of proteins formerly termed albuminoids. They are obtained mainly from "the hard" or supporting structures of the body.

Collagen, the precursor of gelatin, forms the chief constituent of white fibrous tissue and of the organic substance of bone. It also exists in cartilage, where, however, it is mixed with several other bodies (see under mucinoids, p. 308).

Preparation of Collagen.—A piece of tendon is macerated overnight in 1% caustic alkali to remove other proteins, and then washed with water till alkali free. The resulting mass is collagen. Place a piece of this in a flask and boil it for ten minutes with water which is rendered faintly acid with acetic acid. By this treatment, the collagen is transformed into gelatin and, on cooling the solution, it gelatinises.

Gelatin.—This is really the hydride of collagen, the boiling with acidulated water in the above experiment having caused the collagen to take up a molecule of water. Conversely, the gelatin can be reconverted into collagen by heating it to 130° C., whereby it loses water.

EXPERIMENT VIII. Divide a solution of gelatin in lukewarm water into five portions, to which apply the following tests: (1) the Biuret reaction: a violet colour is produced. (2) the xantho-proteic reaction: only a slight colouration is produced. (3) the Millon's test: only a slight reddening of the precipitate occurs on boiling. (4) the glyoxylic test: absent or very faint. (5) half saturation with Am_2SO_4 : salted out.

The reason why the second, third and fourth tests are not very distinct, is because gelatin does not yield aromatic bodies on decomposition, and both these tests depend on the presence of aromatic bodies. Some varieties of gelatin give these reactions more distinctly than others, but absolutely pure gelatin is said not to give them at all, so that their presence is held to depend on native protein in the gelatin.

The other sclero-proteins are unimportant. They are **Keratin**, which occurs in the skin and its appendages and in the medullary sheaths of nerves; it is remarkable for the large percentage of sulphur which it contains; **Elastin**, which is found in elastic fibres, and contains a very small percentage of sulphur, but a considerable amount of aromatic bodies.

All these sclero-proteins except keratin yield glycine as their chief

decomposition product. They also yield the hexone bases, since protamin forms part of their molecule (see table, p. 299).

EXPERIMENT IX. With pieces of finger-nail show that keratin gives xanthoproteic, Millon's, and lead sulphide test.

THE COMPOUND PROTEINS.

In this group we have proteins to which groups other than protein are united to form a complex molecule. The chief groups are:—

- (i) The chromo-proteins.
- (ii) The gluco-proteins.
- (iii) The nucleo-proteins.

The Chromo-proteins.—As the name signifies these are “coloured” proteins, and its members are pigments, of which the chief is haemoglobin. (See chapter on Blood.)

The Gluco-proteins are compounds of protein with a large carbohydrate group. Many proteins not contained in this class, such as egg albumin and nucleo-proteins, contain carbohydrate, but not in such large amounts. The chief members of the class are the *mucins*.

EXPERIMENT X. Collect some saliva in a test tube, note its viscosity; add to it a few drops of 1% acetic acid; a stringy precipitate of mucin results. It is insoluble in excess of acetic acid. Filter. To residue add a few drops of weak sodium carbonate solution, when the precipitate will dissolve. Test this with protein colour tests, including Molisch.

EXPERIMENT XI. Mucin has been prepared from connective tissue where it is very abundant, by extracting the latter with a weak alkali (lime water). The mucin has been precipitated by a weak acid. The resulting precipitate has then been boiled for about ten minutes with hydrochloric acid (1 part concentrated acid + 3 parts water), and the resulting solution cooled and neutralised. Examine portions of the resulting solutions. Divide the solution into portions, *a* and *b*.

To (*a*) apply the Biuret reaction—a violet or pink colour is produced, showing the presence of the protein moiety.

To (*b*) add a drop of copper sulphate solution, and, if necessary, some caustic alkali till a blue solution is obtained. Now boil, when reduction to cuprous oxide will occur, demonstrating the presence of the carbohydrate moiety.

Besides forming the ground substance of the connective tissues, mucin is also secreted on to the surface of all mucous membranes, where it acts as a lubricant.

Besides the mucins, this group also contains the *mucinoids*, bodies distinguished from mucin in not being viscous in nature and not being so easily precipitated by

acetic acid, the precipitate when formed being soluble in excess. They are represented by the mucoïd of ovarian cysts, the ovo-mucoïd of white of egg, and bodies (sometimes termed chondro-proteïds) which occur along with collagen in cartilage. These last on decomposition with an acid yield protein and a reducing body called chondroitin-sulphuric acid, which can further be decomposed to yield chondrosin, a body containing nitrogen, but more strongly reducing than dextrose. This body can still further be decomposed to glucosamine, the usual carbohydrate moiety of the mucins. Of this the mucins contain about 30 %.

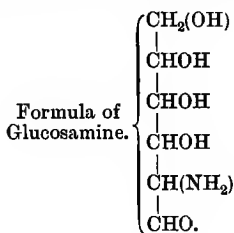

The Nucleo-proteins.—These consist of protein in combination with *nuclein*, and form the chief constituent of the nuclei of cells. Nuclein itself is a compound of protein, with an organic acid known as *nucleic acid*.

PREPARATION OF NUCLEO-PROTEIN.

METHOD I. A cellular organ, such as the thymus or pancreas, is minced and macerated overnight with water made faintly alkaline with caustic soda or ammonia. The extract is then strained through muslin, litmus added, and then weak acetic acid. When the reaction becomes faintly acid, a copious precipitate of nucleo-protein occurs. The nucleo-protein is filtered off and dissolved in weak alkali (1% sodium carbonate).

METHOD II. Demonstration.—The minced organ is pounded in a mortar, with an equal amount of solid NaCl. Upon throwing the mass into excess of water in a tall cylinder, the nucleo-protein rises as a stringy mass to the top of the water. This is collected and dissolved in 1% sodium carbonate.

EXPERIMENT XII. Some of this alkaline solution is supplied—

- (1) Add acetic acid—white precipitate soluble with difficulty in excess. (Cf. mucin, which is insoluble, and caseinogen, which is readily soluble.)
- (2) Perform the protein colour tests.
- (3) Ascertain how it is “salted out.”

Demonstration.—The precipitate of nucleo-protein has been digested with pepsin hydrochloric acid for twenty-four hours. The protein has become converted into peptone—the liberated *nuclein* has fallen down as a brown sediment.

This brown sediment can be further decomposed into *nucleic acid* and protein by dissolving it in alkali and adding 0.3% hydrochloric acid in alcohol. This precipitates the nucleic acid. If this be collected and heated in a sealed tube with hydrochloric acid, it splits into a number of simpler bodies. Guanylic acid, the simplest nucleic acid found in the pancreas, yields phosphoric acid, guanine, and pentose. Other nucleic acids which occur with the guanylic acid yield phosphoric acid, guanine, and adenine, laevulinic acid (probably from decomposition of a hexose), the pyrimidine base cytosine, and probably other pyrimidine bases.

SCHEMA OF RELATIONSHIP OF NUCLEIN, ETC.

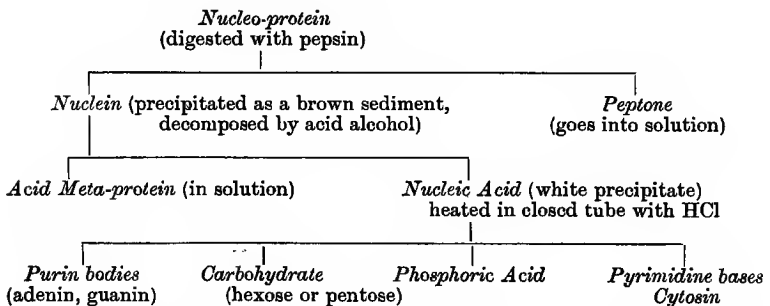

The presence of phosphorus in nucleo-protein may be demonstrated by heating it with combustion mixture (cf. phospho-protein). Its phosphoric acid, however, is *not* split off by incubation with 1% NaOH at 37°C. for 24 hours; nor are nucleo-proteins clotted by the rennet enzyme.

We come lastly to the products of protein hydrolysis, which will be dealt with more fully under Digestion. When albumin is subjected to the action of a weak acid or weak alkali it is transformed into a *derived protein* or *meta-protein*. These closely resemble the globulins.

Acid and Alkali Meta-protein.

EXPERIMENT XIII. To some diluted egg-white add two or three drops of 10% HCl. Place in water bath at body temperature for five minutes. Acid meta-protein is formed.

Note.—(a) That no coagulum now appears on heating.

(b) It is precipitated by making the solution neutral or very faintly alkaline.

(c) It is salted out by *half* saturation with ammonium sulphate (like a globulin).

(d) If neutralised and suspended in water it is coagulated on boiling.

EXPERIMENT XIV. Render dilute egg-white alkaline, and treat as above. Alkali meta-protein is prepared. It gives similar reactions to acid meta-protein. As, however, in making alkali meta-protein some of the loosely combined nitrogen and sulphur are split off, it cannot be changed into acid meta-protein. The reverse change is, however, possible. Acid meta-protein when prepared from muscle (myosin) is often called *syntonin*. Alkali meta-protein when prepared by the action of strong alkalis on protein is termed "Lieberkühn's Jelly." Acid meta-protein is one of the first products of peptic digestion of protein, alkali meta-protein of tryptic digestion.

Proteoses and Peptones.—These occur as the first stages of protein cleavage under the action of such agents as mineral acids, superheated steam, the proteolytic enzymes. They will be more fully studied under Digestion. (See p. 384).

EXPERIMENT XV. Use the solution of Witte's peptone provided and perform the following tests :

- (a) Biuret reaction is *pink*. (*Proteoses and Peptones*.)
- (b) On faintly acidifying with acetic acid and boiling—*no coagulum*.
- (c) Add a little HNO_3 —a white ring. This dissolves on heating and reappears on cooling. Salicyl-sulphonic acid produces the same effect, but the reaction is more delicate.
- (d) To the solution add an equal amount of Am_2SO_4 (half saturate). A white precipitate of the *primary proteoses* (except hetero-proteose) which are salted out. Filter.
- (e) Saturate the filtrate with crystals of Am_2SO_4 . The *secondary proteoses* are salted out. Filter.
- (f) With the filtrate perform Biuret and xanthoproteic tests. To obtain the *Biuret test* in the presence of a large quantity of Am_2SO_4 a large excess of caustic soda is required. As peptones are not precipitated by HNO_3 the xanthoproteic test manifests itself by a yellow colour on heating the solution, turning orange with ammonia. The positive results show the presence of *peptones*.

From these experiments we learn :

- (1) That proteoses and peptones give a pink Biuret.
- (2) That they are not coagulable by heat.
- (3) That proteoses give a precipitate with HNO_3 soluble on heating. Therefore, in the presence of other proteins, precipitated by HNO_3 , such as albumin and globulin, they can be separated by warming the solution and filtering hot.

The precipitates of albumins and globulins do not dissolve on warming.

- (4) Primary proteoses¹ are salted out by *half* saturation with ammonium sulphate.
- (5) Secondary proteoses² are salted out by *full* saturation with ammonium sulphate.
- (6) All proteins but peptones are salted out by full saturation with ammonium sulphate (see table below).

(The other products of protein hydrolysis are fully dealt with under Digestion).

Protein.	Solubility.	Diffusibility.	Action of heat.	Biuret test.	Salting out action of Am_2SO_4 Saturation.	Salting out action of MgSO_4 (full saturation).	Action of HNO_3 or salicyl-sulphonic acid.	Action of alcohol.
Globulin.	Saline but not pure water.	Nil.	Coagulated.	Violet.	By half.	+	Precipitate <i>insol.</i> on heating.	Precipitated then coagulated.
Albumin.	Water.	Nil.	Coagulated.	Violet.	By full.	-	Precipitate <i>insol.</i> on heating.	Precipitated then coagulated.
Primary ¹ proteoses.	Water.	Small.	Not coagulated.	Pink.	By half.	+	Precipitate <i>sol.</i> on heating.	Precipitated.
Secondary ² proteoses.	Water.	Small.	Not coagulated.	Pink.	By full.	-	Little or no precipitate <i>sol.</i> on heating.	Precipitated.
Peptones.	Water.	Great.	Not coagulated.	Pink.	Not.	-	No precipitate.	Precipitated.
Caseinogen.	Weak alkali.	Nil.	Not coagulated.	Violet.	By half.	+	—	Precipitated.

¹ Hetero-proteose is an exception.

² See fuller table on page 386.

CHAPTER VI.

FATS, FATTY ACIDS, PHOSPHORISED FATS AND CHOLESTEROL.

THESE bodies are classified together because they are soluble in the same liquids. After extracting an organ or tissue with alcohol, ether or chloroform, and evaporating off the solvent, a more or less syrupy mass is left behind consisting of a varying mixture of the above mentioned substances. They are often called collectively *the lipoids*.

Method for the Extraction of an Organ or Tissue with Ether.—The simplest method is by means of Soxhlet's apparatus (fig. 225). This consists of an extracting chamber into which opens, near the top, a side tube, connected below with a flask, in which is placed the ether; above it is connected with a condenser. The flask is placed on a water-bath, and the ether passes into the chamber, and then into the Liebig's condenser, where it is condensed and trickles back into the extracting chamber. The ether thus gradually accumulates in the extraction chamber until it reaches the level of the bend in another side tube opening near the bottom of the extracting chamber, when syphon action is established, and the whole of the ether drains back into the distilling flask. The dried tissue or organ to be extracted is finely ground and placed in a cartridge of porous paper, which is inserted in the extracting chamber. The warm condensed ether as it accumulates in the chamber dissolves out the fat, and carries it into the distilling flask. The process should be allowed to proceed for several hours. The contents of the distilling flask are then removed to a flat dish, and the ether allowed to evaporate. The residue contains the lipid substances.



FIG. 225.—Soxhlet's apparatus.

FATS AND FATTY ACIDS.

Neutral fats are the ethereal salts of the fatty acids with the tri-atomic alcohol glycerine, and have therefore the general formula :

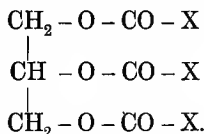

They are named according to the fatty acid they contain, thus : stearin, olein. *The fatty acids* are monobasic organic acids, containing one carboxylic group (COOH) attached to a hydrocarbon radicle. They belong to two classes, the saturated and the unsaturated. The saturated acids have the general formula $\text{C}_n\text{H}_{2n+1}.\text{COOH}$. Those commonly occurring in fats are stearic acid, in which $n = 17$, and palmitic acid, in which

$n = 15$. Thus the formula for stearic acid is $\text{CH}_3 \cdot (\text{CH}_2)_{16} \cdot \text{COOH}$. The first member of this series is acetic acid, $\text{CH}_3 \cdot \text{COOH}$.

The unsaturated acids contain relatively less hydrogen in the hydrocarbon chain attached to the carboxylic group. This is due to the fact that there are one or more double bonds (unsaturated) between the carbon atoms of the chain. Thus oleic acid, the commonly occurring unsaturated acid of fats, has the formula: $\text{CH}_3 \cdot (\text{CH}_2)_7 \cdot \text{CH} = \text{CH}(\text{CH}_2)_7 \cdot \text{COOH}$, and belongs to the series $\text{C}_n\text{H}_{2n-1} \cdot \text{COOH}$. Other unsaturated acids, containing two, or even more, double bonds occur in the fat of the liver, heart and kidney, and in drying oils, such as linseed oil. The unsaturated nature of these acids is shown by their combining directly with chlorine or bromine, thus becoming saturated.

EXPERIMENT I. Shake up some oleic acid or its alcoholic solution with dilute bromine water. The colour of the bromine disappears. Repeat with an alcoholic solution of stearic acid, when the colour of the bromine persists.

Under suitable conditions unsaturated fatty acids and fats will also combine with iodine. The proportion of iodine with which a given mixed fat will combine therefore represents the amount of unsaturated acid present. This is called the Iodine Number of the mixed fat (See p. 322). Common fats are made up almost entirely of varying proportions of stearin, palmitin (which are solid at ordinary temperatures) and olein which is liquid. The more olein a fat contains, therefore, the lower will be its melting point and the higher its iodine number.

All the fatty acids possess one property in common, viz. that they form salts. These salts are called *soaps*. By boiling neutral fat with caustic alkali, it is split up (by a process of hydrolysis) into its constituents, the glycerine being set free and the fatty acid uniting with the alkali to form a soap. This process is called *saponification*.

EXPERIMENT II. *Saponification of Neutral Fat*.—Place about 50 c.c. of strong caustic soda in a dish, and add about 10 grammes of fat. Heat to near the boiling point and stir the mixture frequently. When all the fat has disappeared allow the mixture to cool. The soap forms a jelly or cake, and can be washed in cold water to remove any excess of caustic soda. A hard soap is formed if caustic soda is used; but with caustic potash a soft soap is obtained.

EXPERIMENT III. *Separation of Fatty Acid from Soap*.—Place about 40 c.c. of 20 per cent. sulphuric acid in a small beaker, and heat it nearly to boiling point; drop into this pieces of the washed soap, stirring with a glass rod between each addition. The acid displaces the alkali from its combination with the fatty acid, and the latter separates out on the surface of the water as an oily layer.

EXPERIMENTS IV. *Reactions of Fatty Acids.*—Remove some of the fatty acid with a clean glass rod, and place it on a piece of ordinary paper ; a greasy stain will result.

In order to purify the fatty acid allow the contents of the beaker to cool, when the fatty acid will solidify and can be easily removed with a penknife, and transferred to distilled water in a small beaker. This removes a great part of the adherent sulphuric acid. But to free it completely it is necessary to dissolve the fatty acid in alcohol, and pour the resulting solution into excess of cold distilled water. The fatty acid which separates is filtered off and washed with distilled water. Use the purified fatty acids for the following reactions :—

A. Demonstrate that fatty acid is *acid* in reaction. For this purpose place some alcohol in a test tube, add a few drops of an alcoholic solution of phenolphthalein (an indicator which turns red with alkali, but is colourless with acids), and then a few drops of weak $\frac{N}{10}$ caustic soda. Warm the resulting red solution on the water-bath, and drop into it small pieces of fatty acid. The red colour will disappear. Repeat the experiment with a piece of neutral fat ; the result is negative.

B. Add a piece of fatty acid to some half saturated solution of sodium carbonate, and warm ; the fatty acid dissolves, carbon dioxide is liberated, and a solution of soap is obtained. Neutral fat is insoluble in cold sodium carbonate solution.

C. Press out some fatty acid between filter paper until it is dry, and apply the acrolein test as described in Experiment V. (p. 316). The result is negative.

D. To a solution of soap add : (a) a few drops of a solution of calcium chloride—a white precipitate of a calcium soap falls down ; (b) some lead acetate solution—a white precipitate of lead soap falls down (lead plaster).

The fatty acids prepared by the above method mainly consist of a mixture of palmitic, stearic and oleic. To separate these from one another, advantage is taken of the fact that they differ in the readiness with which they form salts (soaps) with lead acetate.

ADVANCED EXPERIMENT. **To separate the Solid from the Fluid Fatty Acids.**—Melt the fatty acids in a beaker, and add to the resulting fluid about four times its bulk of 70 per cent. alcohol. Place the beaker on the boiling-water bath for a few minutes, and then filter quickly through a folded filter. Allow the filtrate to cool, when the solid acids will separate out as a crystalline mass, whereas the oleic acid will remain in solution. The two can then be separated by filtration. The further separation of stearic from palmitic acid is a laborious process, and consists of the addition of an alcoholic solution of lead acetate in small quantities

at a time to a solution of the acids in alcohol. Each addition produces a precipitate, which is filtered off and treated with dilute hydrochloric acid and ether. The hydrochloric acid decomposes the lead salt, and the liberated fatty acid goes into solution in the ether. This process is called fractional precipitation, and the higher the melting point of the acid the more easily is it precipitated by the lead acetate.

Besides these reactions of the fatty acid produced from it, neutral fat gives an important reaction, depending on the glycerine which it contains. This is called the *acrolein reaction*.

EXPERIMENT V. Place a small piece of fat in a thoroughly dried test tube, add to it three or four times its bulk of acid potassium sulphate,¹ and heat. A pungent vapour of acrolein² is given off, which blackens a piece of filter paper which has been dipped in ammoniacal silver nitrate solution. This reaction demonstrates that the vapour acts as a reducing agent.

Emulsification.—When oil is mixed with water it floats to the surface, but when a soap is present in solution in the water the oil globules remain suspended, and an emulsion results. This is more permanent if some suspending medium such as mucilage be added.

EXPERIMENT VI. In one test tube (*a*) place some soap solution; in another (*b*), some water. To each add some neutral olive oil and shake. Allow to stand, and note that *a* remains emulsified, *b* does not.

EXPERIMENT VII. Place some rancid oil (i.e. containing free fatty acid) in a test tube, add some weak caustic potash solution and shake; an emulsion forms, soap being formed by the alkali combining with the fatty acid.

EXPERIMENT VIII. Divide the emulsion produced in Experiment VII. into two parts; to one of these add a little mucilage or egg-albumin and shake, and note that the emulsion "stands" much longer than that to which no suspending medium has been added.

LECITHINS.

Soluble in acetone, and otherwise very closely related to the fats, is a group of bodies called lecithins. The lecithins are present in greater or less amount in all the cells of the body. Most plentifully, they occur in the envelope and stroma of the red-blood corpuscles, in nervous tissues and in bile. They are also found in plants. Chemically these bodies consist of a glycerine molecule, two of the hydroxyl groups of which are combined with fatty acid and the remaining one with

¹Commercial acid potassium sulphate is often impure and gives a pungent reducing vapour by itself. It is well, therefore, to make a preliminary test with the crystals alone. The impure salt can be readily purified by crystallisation.

²Acrolein is the aldehyde of allyl alcohol and has the formula $\text{CH}_2=\text{CH}-\text{CHO}$.

products. For example, when they are saponified, as above described, they yield fatty acid, glycerinphosphoric acid and cholin. Glycerine-phosphoric acid is readily formed by bringing together glycerine and phosphoric acid.

CHOLESTEROL.

Although soluble in the same solvents as fats and the lecithins, cholesterol is not a fat, but belongs to an entirely different

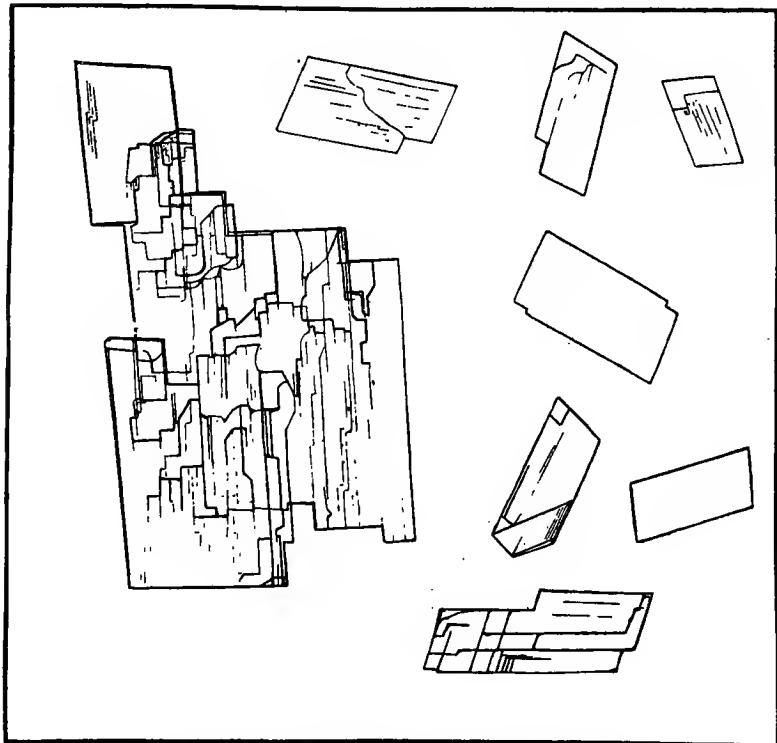
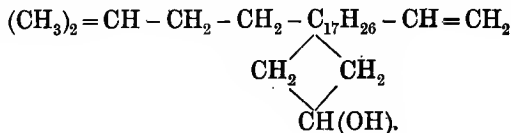

FIG. 226.—Crystals of cholesterol magnified 300 diameters.

chemical group, namely, that of the terpenes. The terpenes are common in plants, examples of them being camphor and turpentine. By its reactions, cholesterol can be shown to contain a double linking and an alcohol-hydroxyl group. The following formula has been suggested for it:—



Like the lecithins it is very widely distributed in the animal body. In the free state, it is present in the envelope and stroma of the red blood corpuscles; as an ester, it is present in the blood serum. It is also present in bile, and it may separate out from this to form calculi, following a catarrhal state of the mucosa of the bile ducts. A variety of cholesterol, called isocholesterol, is found in lanolin (purified wool fat). Although we do not know much about its functions in the animal body, yet there are indications that these must be important. Thus, if added along with lecithin to a suspension of red blood corpuscles, it prevents haemolysis. It also antidotes the haemolytic action of saponin. (See p. 462.)

ADVANCED EXPERIMENT. Preparation of Cholesterol from Gall-Stones.—The gall-stones are finely ground and boiled with 95 per cent. alcohol. The alcoholic extract is filtered hot and allowed to cool, when crystals of cholesterol separate out and can be filtered off, preferably with suction, using a perforated porcelain plate fitted in a glass funnel and covered with a disc of filter paper. The crystals are washed with a little cold alcohol, and may be re-crystallised from hot alcohol.

ADVANCED EXPERIMENT. Preparation of Cholesterol from Tissues, e.g. Brain.—The tissue is minced and then ground in a mortar with sand and about three times its weight of plaster of Paris. After standing for some hours the mass, which has now set hard, is ground in a mortar and cold acetone gradually added. This extracts the cholesterol alone. The acetone is filtered and the extraction repeated three times. On evaporation of the extract almost pure cholesterol is obtained. This may be re-crystallised from hot alcohol. (Rosenheim.)

Cholesterol is recognised by a number of colour reactions, of which the most important are described in the following experiments:—

EXPERIMENT IX. Place some cholesterol crystals on a microscopic slide and distribute them with a glass rod, and examine under the microscope; or better, dissolve some in absolute alcohol, place a drop of the solution on a slide, and allow it to evaporate. The crystals are colourless, glancing rhombic plates having usually a square piece removed from one corner. (Fig. 226.) The crystals give distinctive colour reactions.

Place some cholesterol crystals under a cover slip on a microscopic slide, and allow a drop or so of a mixture of 5 parts sulphuric acid (conc.) and 1 part water to run under the cover slip. Note that the edges of the crystals become red. Now run in a drop of iodine solution, when it will be noted that a play of colours results (brown, violet, blue, etc.).

Other colour reactions can be obtained with solutions of cholesterol.

EXPERIMENT X. Dissolve some cholesterol crystals in a few c.c. of chloroform, and add an equal volume of sulphuric acid (conc.).

Shake gently. On settling, it will be seen that the chloroformic solution becomes coloured blood red and afterwards purple, and the sulphuric acid shows a green fluorescence. If the chloroformic solution be moistened with water, as by pouring it into a moistened test tube the colour disappears. (Salkowski's reaction.)

EXPERIMENT XI. Dissolve some cholesterol in acetic anhydride, and, after cooling, add some sulphuric acid (conc.). A play of colours results. (Liebermann's reaction.)

PROTAGON.

This name is given to a crystalline substance containing phosphorus and nitrogen. It can be prepared from brain tissue by various methods, but perhaps most simply by extraction, by means of hot acetone, of a mixture of gypsum and brain tissue (see p. 319), from which the cholesterol has been previously removed by treatment with cold acetone. The hot extract, after filtration, deposits crystals of so-called protagon on cooling. By fractional precipitation, or by treatment with different solvents, protagon can be shown to be a mixture of different lipoids, some of which contain large amounts of phosphorus (sphingomyelin), whilst others are phosphorus free (phrenosin). Hydrolysis of protagon yields galactose, choline, and other bases. (See table, p. 321.)

FAT VALUES.

For many reasons it is important that the physiologist and hygienist should be acquainted with the chemical methods used for distinguishing the various fats. It is by an application of such methods that the physiologist has been able to show, among other things, that forced feeding with a fat-rich diet (after previous starvation) leads to the deposition in the tissues of fats very similar to those contained in the food. By such methods, also, the hygienist is able to tell when butter, for example, is of proper composition, for it is easy for the merchant to substitute other fats (oleomargarine) for it.

The following are the most important of these methods:—

I. **Melting Point.**—The method for estimating this has been given on p. 277. The absorbability of a fat from the intestine varies inversely with its melting point, *e.g.* mutton fat with a melting point of 44° – 51° C. is absorbed much more slowly than is pig fat with a melting point of 36° – 46° C.

II. Specific Gravity.

EXPERIMENT. Melt pieces of butter and of oleomargarine in two small evaporating dishes, and drop the melted fats into alcohol at room temperature (15° C.). The butter will sink, but the oleomargarine will float, since it is composed of fats of lower specific gravity than those of butter.

III. **Acid Value.**—This refers to the amount of free fatty acid which the specimen of fat contains. When fats become rancid, the acid value rises considerably.

TABLE OF THE CHIEF REACTIONS WHICH DISTINGUISH FATS, FATTY ACIDS, LECITHIN, AND CHOLESTEROL.

	SOLUBILITIES.		Reaction of alcoholic solution towards phenolphthalein.	Acrolein reaction.	Saponifiability with alcoholic potash.	Behaviour towards lipase.	Product on incinerating.	Remarks.
	In alcohol ether, CHCl_3 , etc.	In sodium carbonate solution.						
Neutral fat.	Soluble.	Insoluble.	Neutral.	Positive.	Saponifiable.	Split into fatty acid and glycerine.	Nil.	
Fatty acid.	Soluble.	Soluble.	Acid.	Negative.	Combines with alkali to form soap.	Unaffected.	Nil.	Some fatty acids form characteristic crystals.
Lecithin.	Soluble (less so in ether).	Insoluble.	Neutral.	Positive.	Saponifiable.	Split into fatty acid, glycerine, phosphoric acid and cholin.	H_3PO_4 .	H_3PO_4 and cholin are produced by saponification.
Cholesterol.	Soluble.	Insoluble.	Neutral.	Negative.	Unsaponifiable.	Unaffected.	Nil.	Under microscope forms characteristic crystals; crystals and solutions give characteristic colour reactions.

EXPERIMENT. Dissolve 1 grm. of fat (butter) in as little alcohol as possible (with the addition of ether, if necessary), and, after adding a few drops of phenolphthalein titrate with $\frac{N}{10}$ KOH. The result is expressed as the number of milligrams of KOH required to neutralise the fatty acid of 1 grm. of fat. In the subjoined table the result is calculated as oleic acid on the basis that 1 c.c. $\frac{N}{10}$ KOH equals 0.0282 grm. oleic acid.

IV. The Saponification Value.—This is a measure of the total amount of fatty acid (both free and combined) contained in the fat. The fat is saponified with a known amount of caustic potash which is in excess of that required to produce complete saponification, and the caustic potash which is not neutralised in the process is ascertained by titration against standard acid.

EXPERIMENT. Weigh a dry, clean, wide-mouthed Erlenmeyer flask, and add to it 2 grm. of melted and filtered fat. By means of a pipette add exactly 25 c.c. alcoholic potash, a sample of which has just previously been titrated against $\frac{n}{2}$ HCl, using phenolphthalein as an indicator. Close the flask with a cork having a wide glass tube passing through it. This serves as a reflux condenser. Place the flask on a boiling water bath for half an hour, and shake frequently. Then remove the flask, add 1 c.c. phenolphthalein solution and titrate against $\frac{n}{2}$ HCl. The difference between the amount of acid now required and the amount of acid corresponding to 25 c.c. of the alcoholic potash, as determined by the previous titration, corresponds to the amount of fatty acids. The result is usually calculated in terms of the number of milligrams of KOH required to saponify 1 grm. fat. 1 c.c. $\frac{n}{2}$ KOH contains 0.028 gr. KOH.

V. The Ester (ether) value represents the amount of fatty acid which is combined with glycerine. It is obtained by deducting the acid value (III.) from the saponification value (IV.).

VI. The Iodine value is the percentage amount of iodine which a weighed quantity of fat can absorb. This is proportional to the amount of unsaturated fatty acid (oleic, etc.) in the fat (see p. 314). The iodine value is of great importance in physiological investigations, since by it we can form an estimate of the relative amount of unsaturated fatty acids in fats. Its determination involves the use of carefully standardised solutions, and is too complicated for description here.

VII. The Reichert-Meissl value indicates the amount of volatile soluble fatty acids present. It is of great value in testing the purity of butter, because this contains a considerable proportion of such acids, whereas the cheaper fats, which are sometimes used as substitutes for butter, do not contain much of them.

EXPERIMENT. 5 grm. melted fat is saponified with alcoholic potash, the alcohol evaporated, and the resulting soap dissolved in water acidified with sulphuric acid, and distilled. The distillate, which contains the volatile acids, is collected in a flask and titrated with $\frac{n}{10}$ NaOH, the result being expressed as the number of c.c. of decinormal acid contained in the distillate from five grammes of fatty substance.

The following table gives some of the above values for the fats of greatest physiological importance:—

Name of fat.	Specific gravity at 15° C.	Melting point °C.	Acid value expressed as per cent. oleic acid.	Saponification value.	Iodine value.	Acetyl value of the fatty acid. ¹	Reichert-Meißl value.
Butter, - - -	0·926-0·940	28-33	0·84-2·4	220-245	26-38	9·6-18·2	25-32·8
Mutton, - - -	0·937-0·961	44-51	0·72-9·3	195·2-196·5	32·7-46·2	—	—
Dog, - - -	0·923	37-40	0·7-1·5	194·4-196·4	58·5	9·5-12·3	0·5-0·63
Cat, - - -	0·9304	39-40	1·15-12·8	190·7	54·5	10	0·9
Horse, - - -	0·919-0·933	20-42	0·87-1·22	195·1-199·5	78·8-94	6·6-14	0·44-2·14
Ox, - - -	0·931-0·938	42-49	0·4-0·5	195·8-198·1	39·2-51	—	1·1
Pig, - - -	0·931-0·938	36-46	0·2-2·0	193-200	50-70	—	—
Rabbit, - - -	0·9345-0·9435	35-38	2·35-4·85	198·3-200·3	96·9-102·8	41·7	—

¹The acetyl value indicates how much "hydroxyl" the fatty acid contains.

CHAPTER VII.

MILK.

MILK contains proteins, fats, carbohydrate, salts and water. The fat is suspended in the form of a fine emulsion. The proportion of these bodies varies in the milks of different animals. Naturally that provided by the animal is the best for its own species. The more quickly a young animal grows the greater is the percentage of protein and salt, in the mother's milk. Thus, a puppy doubles its weight in eight days; its mother's milk contains 7.1 per cent. of protein and 1.3 per cent. of ash. On the other hand, a child takes half a year to double its weight; human milk contains only 1.5 per cent. protein and 0.2 per cent. ash. The mother's milk forms a perfect food for the young growing animal—but it is deficient in iron. It has been shown that the young animal has sufficient iron stored within itself until it can begin to get its own further supply of iron. Thus the young rabbit contains within itself a sufficient supply until it is able to eat green food. This is important from the medical point of view, and shows the necessity of weaning a child at the proper time in order that a proper supply of iron may be obtained in the food.

In everyday life the two kinds of milk of the greatest importance are cow's milk and human milk. As hinted above, the two milks vary in composition.

	Water.	Protein.	Fat.	Carbohydrate.	Salts.
Cow's milk,	87.4	3.4	3.7	4.8	.7
Human milk,	90.2	1.5	3.1	5.0	.2

Other milks used for human consumption are :—

	Water.	Protein.	Fat.	Sugar.	Salts.
Goat's,	87.3	3.5	3.9	4.4	.8
Ass's,	92.5	1.7	.4	5.0	.4

It will be seen that, as regards cow's and human milk, the amount of fat and of carbohydrate is nearly the same in both, the amount of protein and salts is more in cow's than in human milk. To make cow's milk, therefore, of approximately the same *percentage composition* as human milk, it is usual to dilute it with an equal bulk of water and to add fat and carbohydrate in proportion. This fat is usually in the form of cream, but, in the case of the very poor, cotton-seed oil will serve a similar purpose. Similarly with the carbohydrate—that of milk is milk-sugar or lactose and is expensive—but the addition of cane sugar serves well and if anything renders the milk more palatable. In passing, it may also be noted that a good non-skimmed

condensed milk diluted in suitable proportions, such a 1 in 12 to begin with, forms a good inexpensive substitute for human milk.

But when these alterations have been made in cow's milk it has only the same percentage composition—and certain well-marked differences must be pointed out. Such differences are:—

(1) The proportion between the amount of the different kinds of protein in cow's and human milk.

Cow's milk,	3.02	per cent.	caseinogen,	.53	per cent.	lactalbumin.
Human „	1.00	„	„	.50	„	„

It will be seen that human milk contains relatively far more lactalbumin than does cow's milk, so that even when cow's milk is diluted there is the discrepancy between the relative amount of the proteins to be taken into account. It is stated that if lactalbumin be added to diluted cow's milk it causes it to yield the same light form of clot as does human milk. It is also interesting to note that the first secreted milk, colostrum, is very rich in lactalbumin.

(2) The caseinogens of the two milks are not of the same composition either in percentage or actual composition. It has recently been shown that a carbohydrate group is attached to the caseinogen of human milk, such a group is absent from that of cow's milk.

(3) The percentage of the salts present differs in the two milks—cow's milk contains more calcium, iron and phosphoric acid; human milk more potassium and chlorine.

(4) There is a provision in the mother's milk of protective bodies for her offspring. Perhaps the strongest argument for the human mother to nurse her child wherever it is possible, is shown by the "changeling experiments" of Ehrlich. This eminent researcher performed the following remarkable experiments. He immunised a male and a female mouse to the poison abrin before they were allowed to reproduce. He then crossed the immunised male with a non-immunised female, and the immunised female with a non-immunised male. Upon the birth of the young, it was found that those of the immunised female possessed an immunity to the poison, which *increased after birth*, and was therefore not derived from the placenta alone; whereas the young of the non-immunised female—that is, of the immunised male—possessed no immunity towards the poison. The families were now changed over, the immunised mother suckling the non-immune young, and *vice versa*. It was then found that the once non-immune young acquired an immunity, whereas the immune-born young quickly lost theirs. These results are all the more remarkable, because a similar immunity cannot be produced in the adult animal by feeding it upon

an immunised cadaver, yet the young mouse can be immunised through its food. This points either to a special condition of the antitoxins in the milk of the mother or to a special condition of digestion in the young.

In order to study the chemistry of milk, we usually employ cow's milk, because it is easily obtainable.

Cow's Milk.—This is an opalescent solution, possessing a characteristic taste, and of amphoteric reaction.

EXPERIMENT I. Place a drop of fresh milk on a piece of red litmus paper, and wash it off with distilled water; a blue stain is left: if the drop be placed on blue litmus, a red stain is left. This peculiar reaction is due to the fact that milk contains a mixture of acid and alkaline salts. By ascertaining how much decinormal acid or alkali are required to produce neutralisation with the aid of different indicators the amount of each of these kinds of salt can be determined. (See Titration Methods.)

The *specific gravity* of fresh milk varies between 1·028 and 1·0345. The more fat (*i.e.* cream) the milk contains the lower is the specific gravity.

EXPERIMENT II. Estimate by a hydrometer (p. 409) the specific gravity (*a*) in skimmed milk and (*b*) in fresh milk. In the former it is about 1·0345, in the latter 1·028. By adding water to (*a*) the specific gravity obviously falls, and by removing the cream from (*b*) it rises. In dairy hygiene, a rough estimate of the richness of milk in cream is obtained by ascertaining its specific gravity, but it is clear from the above experiment that some of the cream can be removed and the consequent rise in specific gravity masked by the addition of water. This fraudulent trick of some dairymen must, therefore, be borne in mind before giving an opinion of the quality of the milk.

Fresh milk does not coagulate on boiling, but a skin forms on its surface. A similar skin is produced when any emulsion containing protein is boiled, and in the case of milk it is composed chiefly of caseinogen entangling some fat globules.¹ Its formation is due to drying of the protein at the surface of the milk.

THE CHEMICAL CONSTITUENTS OF MILK.

I. Proteins.—The chief protein of milk is a phospho-protein called *Caseinogen*. This can be precipitated by adding to the diluted milk a

¹ An emulsion of cod-liver oil in diluted blood-serum is given round; warm it to about 50° C., and a skin will form on the surface. Be careful not to heat above 50° C., as then coagulation of the proteins will be produced.

weak acid, or by saturating it with a neutral salt. (See Phosphoproteins, p. 306.)

EXPERIMENT III. Place about 5 c.c. of milk in a test tube, and dilute with an equal bulk of water. To this diluted milk add, drop by drop, a weak solution of acetic acid; a precipitate of caseinogen, entangling fat, falls down. Filter off this precipitate and wash it with water. Now add to it a weak solution of Na_2CO_3 ; the precipitate dissolves, and an opalescent solution of caseinogen, still, however, containing some fat, passes through the filter. By repeated reprecipitation and filtration comparatively pure caseinogen can be obtained, from which the last traces of fat can be removed by treating with ether.

The chief property of caseinogen is its power to clot when treated with *rennin* (a ferment contained in gastric juice) in the presence of soluble calcium salts.

EXPERIMENT IV. Take a pure solution of caseinogen. Divide it into two portions, *a* and *b*. To both add about ten drops of rennin ferment. To *b* add also a few drops of a 5% solution of calcium chloride. Place both in the water bath at 40°C .; after about five minutes examine to see if clotting has occurred. It will be found that clotting has occurred in *b* where both rennin and soluble Ca salts were present.

EXPERIMENT V. Make similar experiments with milk, taking five tubes, *a*, *b*, *c*, *d*, *e*.

a = milk + rennin only.

b = milk + rennin + CaCl_2 .

c = milk + rennin (heated).

d = milk + rennin + potassium oxalate solution.

e = milk + rennin + potassium oxalate solution (heated after 10 minutes).

It will be found that *a* clots, but not so quickly as *b*; *c* does not clot, because the enzyme has been destroyed; *d* clots only after the addition of CaCl_2 ; *e* clots also on the addition of CaCl_2 any time even after the rennin has been destroyed.

From these experiments we learn that the clotting of milk takes place in two stages.

(1) The rearrangement of the soluble caseinogen into the form of soluble casein by the enzyme rennin.

(2) The combination of the soluble casein thus formed with calcium salts to form insoluble casein or clot.

Note that the enzyme rennin does *not* clot the protein; it merely rearranges it in such a form that it can be clotted.

The rennin comes from a precursor pro-rennin in the gastric mucous membrane.

The stages can therefore be tabulated as follows :

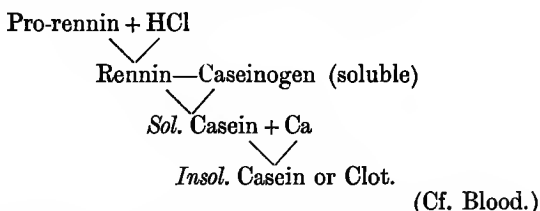

In order to study the conditions necessary for the clotting of milk a solution of caseinogen may be prepared by the following method (Ringer's):

300 c.c. of milk are mixed with an equal bulk of water, and 10% acetic acid is added till all the caseinogen has been precipitated. The precipitate is filtered off and thoroughly washed with distilled water until the washings are no longer acid in reaction. It is then removed from the filter paper, and ground up in a mortar with solid calcium carbonate. The resulting paste is thrown into 500 c.c. of water placed in a tall vessel, and the solution is allowed to stand for several hours. The fat, which was contained in the precipitate, rises to the surface, the calcium carbonate sinks to the bottom, and the intervening fluid contains the caseinogen in combination with calcium as calcium caseinogenate, which is soluble in water (Osborne).

Three samples of the opalescent solution are removed by means of a pipette, and placed in three test tubes labelled *A*, *B*, and *C*. To *A* are added a few drops of rennin; to *B* a few drops of a 0.5% phosphoric acid and some rennin; to *C* a few drops of a 0.2% solution of calcium chloride and some rennin.

The three test tubes are placed in the water bath at 40° C., when it will be noticed that coagulation occurs only in *B* and *C*, in which, besides the ferment, soluble calcium salts are present.¹ In *A*, although no visible change has taken place, the caseinogen has been converted into the so-called *soluble casein*, and all that is necessary for the production of clotting is the presence of calcium in solution. That this is so can be demonstrated by boiling the solution *A* so as to destroy the ferment, then cooling and adding a few drops of a 2% solution of calcium chloride, when a clot will at once form.

The fluid left after the clotting of the caseinogen is known as whey—in this case rennet whey. If the caseinogen be got rid of by acid, it is known as “acid whey”; if by “salting out,” as “salt whey”; if by alcohol, “alcoholic whey,” and so on. These wheys are different in composition; for instance, rennet whey and acid whey contain lactalbumin, salt whey and alcoholic whey do not.

EXPERIMENT VI. Apply the xanthoproteic reaction to some acid whey: a positive result is obtained. Apply also the other protein colour tests. Acidify some of the whey with acetic acid and boil; the

¹The phosphoric acid added to *B* brings some of the Ca salts suspended in the opalescent fluid into solution.

protein is coagulated. The proteins are called lact-albumin and lact-globulin.

II. The Carbohydrate Lactose.

EXPERIMENT VII. Boil some rennet whey which has been weakly acidified with acetic acid. Filter off the coagulated proteins. To the filtrate apply Trommer's or Fehling's test; reduction is effected. Barfoed's reagent is not reduced.

Lactose does not, like dextrose, readily ferment with yeast, but it is capable of undergoing a special fermentation, which changes it into lactic acid. This is called the lactic acid fermentation. It depends on the presence of a microbe, the *bacillus acidi lactici*. It occurs in two stages as follows:—

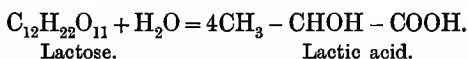

Some of the lactic acid is then further split up into butyric acid.

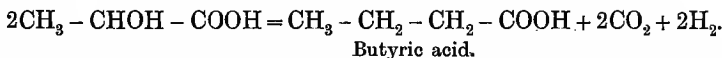

The presence of these free acids in the milk leads to the *precipitation* of caseinogen, and this explains the production of the *curd* in sour milk. It is quite a different thing from the *curd* which is produced by rennin. Thus, it can be dissolved by means of a weak alkali, and if rennin be added to the resulting solution true clotting will follow.

Milk, however, will undergo alcoholic fermentation by a special fungus, known as the kephir fungus. From cow's milk the drink *kephir* is formed, from mare's milk the drink *koumiss*. They contain from 1–3 % of alcohol, and when clotted give a fine clot. For this reason they have been recommended for invalids.

EXPERIMENT VIII. Take some sour whey. Add a few drops of it to Uffelmann's reagent,¹ when the dark purple colour of the latter will be changed to yellow. Test for lactic acid (see p. 379).

III. The salts of milk are chiefly phosphates and chlorides of the alkalis and alkaline earths. A trace—0.00035 %—of iron is also present.

EXPERIMENT IX. THE DETECTION OF PHOSPHATES AND CHLORIDES. —Add to 5 c.c. of protein-free whey half its bulk of nitric acid and about twice its bulk of a solution of molybdate of ammonia in nitric acid. Warm gently on the water bath, and a yellow precipitate of *phosphate* forms. In rennet or acid whey the phosphates may be precipitated by ammoniated magnesium citrate. Filter. Dissolve

¹This reagent is made by adding a trace of ferric chloride to a 1% solution of carbolic acid.

precipitate in nitric acid and heat as before with ammonium molybdate. Show the presence of chlorides by means of silver nitrate test—a white precipitate insoluble in nitric acid, soluble in ammonia.

EXPERIMENT X. THE DETECTION OF CALCIUM SALTS.—To some whey, freed from protein by boiling, add a few drops of a solution of potassium oxalate—a white haze of calcium oxalate results.

IV. The Fats of Milk.—Examine a thin film of milk under the microscope, and note that the fat consists of small spherical bodies, which are transparent and do not adhere to one another.

The fat can be removed by shaking the milk with ether after the addition to it of a few drops of weak NaOH solution.

EXPERIMENT XI. To about 5 c.c. of milk in a test tube add two drops of caustic soda (20 %), and then about 5 c.c. of ether. Cover the top of the tube with the thumb and shake the mixture, occasionally lifting the thumb slightly to allow the vapour of ether to escape. The ether will dissolve the fat, and the milk will become much less opaque. By adding alkali, a certain amount of the caseinogen is changed in its physical condition, so that the caseinogen films, which lie between and thereby hold apart the fat globules, are diminished, and consequently the fat globules are dissolved by ether. So long as they are surrounded by caseinogen molecules they are not acted on by ether. Not only alkalis, but also acids can effect this change.

When the milk stands for some time, the fats, being specifically lighter, rise to the surface to form the *cream*, and if this be mechanically agitated it solidifies to form *butter*. Analysis of an ethereal extract of milk shows that the fats are olein 40 %, palmitin 33 %, stearin 16 %, and about 7 % of lower fatty acids, such as butyrin. There are minute traces of lecithin and cholesterol.

Colostrum.—The milk which first appears during lactation is yellow in colour and of higher specific gravity than that secreted later. On boiling, it yields a distinct coagulum of albumin and globulin, and if examined under the microscope it will be found to contain numerous cells—*colostrum corpuscles*—in the protoplasm of which fat globules are present. These cells are, in reality, secretory cells of the mammary glands which have been extruded in the first portions of milk.

The Quantitative Determination of the various Bodies in Milk.—The methods here described can be employed for other fluids besides milk.

(1) **The Percentage of Water.**—A weighed quantity of milk is mixed with a weighed quantity of fine quartz sand, which has been previously heated to redness and then cooled in a desiccator. The weight of the mixture is accurately determined, and it is then placed in a hot air bath heated to 100° C. until all the water has been driven off and the weight is constant. The amount of weight lost corresponds to the amount of water which the sample of milk contains.

(2) **The Percentage of Protein.**—Three grs. of milk are diluted with four times its volume of distilled water, a few c.c. of a solution of sodium chloride are added, and then a solution of tannic acid until all the protein has been precipitated. The precipitate is filtered off through an ash-free filter paper, and thoroughly washed with distilled water. The filter paper with the precipitate is removed to a Kjeldahl's combustion flask, and the nitrogen estimated as described on p. 410. The result multiplied by 6.37 gives the total amount of protein contained in the sample of milk.

(3) **The Percentage of Fat.**—The dietetic value of a milk depends to a large extent on the amount of fat it contains. There are, therefore, numerous methods employed for the quantitative estimation of this, some of which are only approximate. The following method (Adam's) will be found very simple and sufficiently accurate for most purposes :

Measure 5 c.c. milk and drop it on to a strip of Adam's fat-free porous paper ;¹ allow this to dry in the air bath at 60° C., then roll it up and place it in the extractor of Soxhlet's apparatus (see p. 313). The weight of the distilling flask is ascertained before beginning the extraction, and then again after the extraction has been allowed to proceed for about one hour and the ether has been distilled off; the increase of weight gives the amount of fat in 5 c.c. of milk. Sufficient ether should be used to fill the Soxhlet one and a half times, and it should be made to siphon over at least twelve times.

(4) **The Percentage of Sugar.**—Ten c.c. milk are mixed with twice that amount of alcohol (meth. spt.) so as to precipitate all the protein, which is then filtered off. The precipitate is thoroughly washed with alcohol, and the washings are then placed on the water-bath till all the alcohol has evaporated. The contents of the evaporating basin are then carefully washed into a 100 c.c. measuring cylinder, and the volume made up to 100 c.c. This is then placed in a burette and titrated with boiling Fehling's solution, as described on p. 45.0 Ten c.c. Fehling's solution correspond to 0.0676 g. lactose, therefore the number of c.c.'s of the diluted extract required contains 0.0676 grm. lactose. In order to calculate the percentage it must be remembered that each c.c. of the solution in the burette corresponds to 0.1 c.c. of the original milk.

(5) **The Percentage of Ash.**—A weighed quantity of milk is evaporated to dryness on a water bath in a weighed crucible. The crucible is carefully heated over a free flame until a perfectly dry and black ash has been obtained. The flame is now strengthened and the ash is heated until it becomes white. The crucible is then allowed to cool in a desiccator, after which it is weighed.

CHAPTER VIII.

BLOOD.

To the unaided eye, ordinary vertebrate blood appears to be a homogeneous red fluid, but microscopical examination shows that the red colour is really due to certain formed elements, the red corpuscles,

¹ The paper can be obtained from any of the dealers.

suspended in an almost colourless fluid, the plasma. In this fluid, too, are certain other corpuscles, which, being colourless, are known as the white corpuscles. When blood is shed, it sets at first to a red jelly. After a time this jelly contracts and gradually squeezes out a pale yellowish fluid, known as the serum. The blood of different species clots at different rates, but the process is essentially the same.

THE CLOTTING OF BLOOD.

Demonstration.—Inspect the blood clot in the large vessel placed for demonstration purposes. Notice that the shrunken clot floats in the serum. If it be a clot of horse's blood, notice the "buffy coat" at the top, due to the fact that the heavier red corpuscles have had time to sink before the blood clotted, thereby leaving the white corpuscles in abundance at the top. These form "the buffy coat."

EXPERIMENT I. Carefully sterilise a needle, prick the finger, and draw some blood into a fine capillary tube. Place aside and examine under the microscope at the end of the lesson.

In order to study the nature of the processes involved in the coagulation of blood, it is essential to stop clotting from taking place. This can be done in several ways, such as by receiving blood into certain neutral salts ($\frac{1}{4}$ volume of magnesium sulphate, equal volume of sodium sulphate), or into a soluble citrate, oxalate, or fluoride. How these bodies act we shall consider later. Upon standing, the corpuscles will gradually sink, and the supernatant plasma can be pipetted off, or, what is better, the mixture can be centrifugalised and the plasma more quickly obtained. The plasma bears the name indicating its method of preparation; we get therefore "*salted plasma*," with magnesium sulphate and sodium sulphate, "*oxalate plasma*," "*fluoride plasma*," and so on.

EXPERIMENT II. Of the "salted plasma" provided, take about 5 c.c. in three tubes, *a*, *b*, *c*. Dilute each six times with water. Leave *a* as it is. To *b* add a few drops of serum. To *c* add a few drops of serum which has been previously heated for several seconds at 60° C. Place all three in a water bath at 37° C. Note that *a* and *c* clot at about the same time, *b* clots much more quickly.

From this we learn:—(1) that salted plasma clots on dilution; (2) that the process is quickened by the addition of serum; (3) that the quickening power of the serum is destroyed by previously heating to 60° C.

EXPERIMENT III. Take about 5 c.c. of oxalate plasma in four tubes, *a*, *b*, *c*, *d*. Leave *a* as it is. To *b* add a few drops of serum. To *c*

add a few drops of calcium chloride solution. To *d* add an equal volume of saturated sodium chloride solution. Filter off the flocculent precipitate and keep for the next experiment, which should be performed as soon as possible. To the filtrate add some calcium chloride solution. Place all in a water bath at 37° C. It will be found that *a* has not clotted, that *b* and *c* have clotted, that the filtrate *d* has not clotted.

From these experiments, we gather (1) that blood will not clot when the calcium salts have been removed by an oxalate; (2) that serum can clot oxalate blood (that is, blood without the presence of calcium salts), because it contains the necessary enzyme already formed in it; (3) that oxalate blood will clot when calcium is added to it, because with free calcium available the coagulating enzyme is formed; (4) that the body

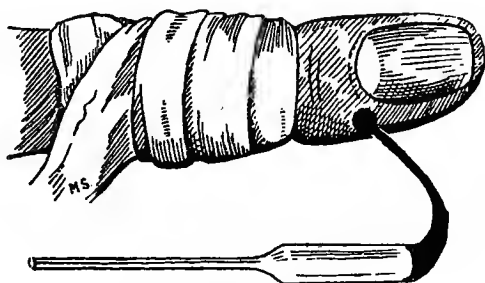

FIG. 227.—Collection of blood.

coagulated is a protein thrown out of solution by half saturation with sodium chloride solution. This body is known as *fibrinogen*. It is insoluble in distilled water and easily thrown out of solution by saturation with salts, and, therefore, belongs to the globulin class of proteins.

EXPERIMENT IV. Quickly redissolve in water the precipitate obtained in Experiment III. *d*. The salt adhering to the precipitate forms a dilute saline solution, in which the precipitate dissolves. Test the solution obtained for protein by the colour tests.

EXPERIMENT V. Into the bent capillary tubes provided collect, as shown in Fig. 227, some of your own blood, first introducing a small quantity of anti-coagulant fluid, preferably 10% sodium citrate, since sedimentation is most rapid with this solution; 1% potassium oxalate or 3% sodium fluoride may also be used. Having sealed off the ends, under the demonstrator's supervision, hang it upon the centrifuge by the bent end. With the plasma so obtained, perform experiments such

as those given in Experiment III. Sodium citrate, it will be found, acts like oxalate. This is not because it precipitates the calcium, but because it combines with it to form a soluble citrate, a salt which does not ionise (dissociate) in solution, and therefore leaves no calcium free to aid in the formation of thrombin. If fluoride has been used, it will be found that the addition of calcium salts to the plasma does *not* cause a clot to form, showing that the fluoride in some way prevents the formation of the enzyme from the pro-enzyme.

We are now in a position to discuss the chief phenomena concerned in the coagulation of blood. We have learnt that a soluble protein, fibrinogen, under the action of an enzyme called thrombin, is turned into an insoluble protein termed fibrin. In the absence of calcium salts blood will not clot, not because this enzyme cannot act, but because it cannot be formed from the pro-enzyme thrombogen in the absence of such salts. It has recently been shown also that the admixture of tissue juice plays an important part in the liberation of the enzyme from the pro-enzyme. It is well known that jagged wounds stop bleeding more easily than clean-cut wounds, as also do wounds through a thick piece of skin compared to those through a thin piece. Similarly, the coagulation of bird's blood, which normally clots very slowly if the blood has not come in contact with foreign tissues, can be greatly hastened by the addition of some tissue juice. This body existing in the tissue juice is known as thrombokinase. The pro-enzyme is present in the plasma, as it is precipitated with fibrinogen from bird's plasma on the addition of distilled water. In mammals the thrombokinase is also yielded by the disintegration of the white corpuscles and the platelets.¹ We can therefore draw up the following table for the coagulation of blood:—

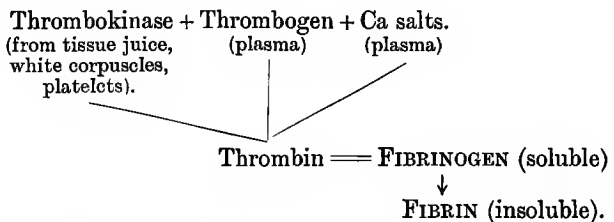

(Compare this with the clotting of milk (p. 328), noting the difference

¹ Different authorities hold different views as regards blood platelets. Some regard them as an actual corpuscle. Others look upon them rather as products of asphyxiated blood—coming either from the disintegration of the white corpuscles or the fine coagulation of the blood proteins.

in the action of the calcium salts and in the part played by the enzyme.)

Conditions which retard Clotting.—(1) *Cold*—receive the blood into a vessel placed in ice (*i.e.* keep it at a temperature a little above freezing point). The enzyme action is inhibited by cold. The blood clots on warming.

(2) *Contact with blood-vessel wall.*—“The living test tube.” This is made by ligaturing in two places a vein of a large animal, such as the jugular vein of the horse. In the tube thus formed the blood does not clot, and if it be hung up the corpuscles gradually sink to the bottom, leaving the unclotted plasma above.

(3) Addition of *certain neutral salts.*—“Salted plasma” (cf. Experiment II.).

(4) Addition of *a soluble oxalate.*—“Oxalate plasma” (cf. Experiment III.)

(5) Addition of *a soluble citrate.*—“Citrate plasma” (see Experiment V.).

(6) Addition of *a soluble fluoride.*—“Fluoride plasma.” This plasma will not clot upon the addition of calcium (see Experiment V.).

(7) Addition of *leech extract* (Hirudin).—This is a secretion produced by the salivary glands of the leech, and which can be obtained by extracting the heads with water. It acts because it contains an anti-thrombin.

(8) *Contact with oil.*—Receive the blood into a smooth vessel smeared with oil.

(9) *Intra-vitam methods.*—These consist in injecting certain substances into the blood-vessels of the animal before bleeding it. These substances are:—

(a) Commercial peptone, which consists mainly of proteoses.

(β) Soap solution.

(γ) A weak alkaline solution of nucleo-protein injected *slowly*—the so-called “*negative phase*” of nucleo-protein injection.

Peptone acts by causing the liver to form a large amount of *anti-thrombin*, which normally keeps blood from clotting inside the vessels. The exact action of nucleo-protein is not well understood.

Conditions which hasten Clotting.—(1) *Body temperature.*

(2) *The addition of some clotted blood* (clot or serum).

(3) *Agitation, e.g.* whipping the blood with a bunch of twigs. This is a very general method of keeping blood fluid when it is not desired to study the phenomena of clotting.¹

¹It is important to remember that this is no longer normal blood, but de-fibrinated blood.

(4) *Contact with a rough surface* (cf. effect of receiving into oil).

(5) *Addition of calcium salts.*

(6) *Intra-vitam methods* causing blood to clot within the vessels:—

(a) Injury or death of blood-vessel wall. When an artery is crushed, as in a contused or lacerated wound, a clot forms, which acts as a natural plug to prevent haemorrhage. When the arterial wall undergoes degeneration a clot or *thrombus*, as it is termed, may form. Similarly, when a blood-vessel is ligatured the inner coat is injured, and a clot forms for a short distance from the ligature. This clotting is due to the liberation of thrombokinase from the injured tissues, causing the formation of some thrombin. That the clot does not extend indefinitely in the blood is due to two causes: (a) thrombin is adsorbed into the fibrin it precipitates; and (b) the formation of anti-thrombin.

(b) *Rapid* injection into a vein of a strong alkaline solution of nucleo-protein; the so-called "*positive phase*" of nucleo-protein injection.

Preparation of Fibrin Ferment.—Blood serum, or some defibrinated blood, is mixed with twenty times its bulk of alcohol. A copious white precipitate is obtained. Allow this to stand under the alcohol for two months. By this time all the other proteins present will be coagulated, except fibrin ferment. The fluid is pipetted off, the sediment carefully collected on a filter, and after the alcohol has drained off ground up in a mortar with water. This extracts the fibrin ferment. Filter, and keep filtrate.

BLOOD SERUM.

Proteins. EXPERIMENT VI. Divide into three portions—*a, b, c.*

(a) Allow *a* to drop gradually into a beaker filled with distilled water; a cloud forms round each drop as it mixes with the water. This is due to the precipitation of the globulin present, as there is now too little saline present to keep it in solution.

(b) Saturate *b* with crystals of magnesium sulphate; a precipitate of globulin occurs. Filter. Show that the filtrate contains albumin (i) by faintly acidifying with acetic acid and heating in a water bath—note the temperature at which the albumin coagulates (77° – 79° C.); (ii) fully saturating the solution with ammonium sulphate.

Redissolve the precipitate of globulin in water; faintly acidify and note the temperature of heat coagulation (75° C.).

(c) To *c* add an equal amount of fully saturated Am_2SO_4 (*half* saturation). The globulin is precipitated. Filter and *fully* saturate (add solid crystals) with Am_2SO_4 ; a precipitate of albumin results.

Salts.

EXPERIMENT VII. Faintly acidify the serum and boil to coagulate the proteins. Filter. Test the filtrate for:—

- (a) chlorides by silver nitrate—white precipitate insoluble in nitric acid ;
- (b) phosphates—white precipitate on addition of ammoniacal magnesium citrate solution. Filter off this precipitate. Dissolve in nitric acid, and heat with nitro-molybdic acid—yellow precipitate ;
- (c) sulphates—white precipitate with barium chloride, insoluble in hydrochloric acid.

In all three tests phosphates are precipitated, but in (a) they are soluble in nitric acid, in (c) they are dissolved by hydrochloric acid. (Cf. salts of urine.)

The amount of sulphate present is usually very small. This filtrate may also be tested for sugar by Fehling's or Nylander's test.

The Estimation of Sugar in Blood.—To estimate sugar in blood it is necessary that the proteins and haemoglobin be removed. This is most easily done by *Waymouth Reid's method*. Into a beaker of about 600 c.c. capacity are placed 250 c.c. of a 7% solution of phospho-tungstic acid containing 2% HCl and the whole is weighed. The blood is then added, the contents well stirred, and the beaker again weighed. The difference in weight gives the amount of blood added. The beaker is then heated on a sand bath (or better still an oil bath), its contents being meanwhile briskly stirred. The proteins including the haemoglobin are, by this treatment, precipitated and form at first a brown gummy mass floating in a clear liquid. After a little the coagulum becomes brittle and sinks to the bottom of the beaker. Great care must now be taken that the beaker does not crack. When all the coagulum has settled to the bottom, the beaker is cooled and the supernatant fluid filtered through paper into an evaporating dish, the paper well washed into the same dish, the contents of the latter nearly neutralised with NaOH, but left faintly acid, and the evaporating dish then placed on a boiling water bath.

While the above fluid is evaporating the brittle protein precipitate is removed from the beaker to a mortar, ground up with some water till a chocolate-like paste is obtained and then washed on to a large suction filter plate and sucked dry. It is washed with water three times. The washings are then transferred to a 2 litre flask, nearly neutralised and boiled down to a small volume (50 c.c.) with the flask on the slant. The evaporated washings are then mixed with the contents of the evaporating dish (the evaporated supernatant fluid) and the whole brought to a volume of 50 c.c., after which it is cooled, almost neutralised, filtered through a small filter paper, the filter washed and the volume of the filtrate and washings brought up to 100 c.c. The sugar is then estimated in this by one of the methods described on page 450.

Blood Plasma.—All the above bodies are present in plasma, which contains one substance in addition, namely, Fibrinogen. We have already shown this (Expt. III. d). Plasma, however, does not contain thrombin ; serum does.

When we remember the function of the blood it is obvious that there are many bodies other than the above present in both plasma

and serum in small quantities. Thus the blood carries the food materials to the tissues, and the products of metabolism away from them. We have, therefore, in addition to ammonia, small quantities of nitrogenous extractives:—urea, uric acid, creatinin, xanthin, hypoxanthin, etc.; of non-nitrogenous extractives, fats, cholesterol, lactic acid, and other organic acids.

In the plasma, too, in very minute quantities, are bodies which play an important part in regulating bodily functions—namely, the internal secretions of such glands as the thyroid, parathyroid, suprarenal, pituitary and sexual organs; also such protective bodies as immune bodies, antitoxins, haemolysins and precipitins.

The percentage composition of the plasma varies with different animals. The following are two analyses:

Water,	-	90.29	}	90.80
Solids,	-	9.71		9.16
Proteins	< fibrin,	.40		1.01
	other,	7.88		7.76
Extractives,	-	.56		.52
Inorganic salts,	-	.85	.81	

It will be seen that the amounts of the different proteins present vary in the plasma. This can also be seen from the following table showing the amount in 1000 parts of plasma:

Animal.	Total protein.	Albumin.	Globulin.	Fibrinogen.
Man,	72.6	40.1	28.3	4.2
Dog,	60.3	31.7	22.6	6.0
Sheep,	72.9	38.3	30.0	4.6
Horse,	80.4	28.0	47.9	4.5

When it is remembered that each of these proteins has probably also a different composition, it can easily be realised how different in composition are the plasmas of different animals (see also chapter on Precipitins, etc.).

THE CHEMISTRY OF THE LEUCOCYTES.

These are morphologically the same as other cells, and they contain the same chemical substances. The *protoplasm* consists mainly of water. The solids consist of various proteins, which chiefly belong to the group of compound proteins (gluco-proteins and nucleo-proteins), and there is also a small amount of albumin and globulin. The protoplasm may also contain such substances as glycogen, fat, mucin, etc., which have either been produced by the activity of the protoplasm, or which are simply deposited in the cell for storage purposes.

The *nucleus* seems to consist mainly of nucleo-proteins, nuclein and nucleic acid. The nucleo-protein of the nucleus is said to contain a higher percentage of phosphorus than does that of the protoplasm.

THE HAEMOCYTES OR RED BLOOD CORPUSCLES.

Structurally these are said to consist of a **stroma** containing in its meshes a chromo-protein called **Haemoglobin**. It is, however, impossible to demonstrate this stroma histologically, and some authorities believe that the haemoglobin is merely contained in a colloidal state in a protein envelope.

Chemically they contain about 60 % of water and nearly 36 % of haemoglobin, the remaining 4 %—represented by the so-called stroma—consisting of lecithin, cholesterol and nucleo-protein.

Haemoglobin.—This is a compound protein containing 0.4 % of iron. When decomposed by acids or alkalies it splits up into a protein of the nature of a histone (see p. 305) called **globin** and into a pigment called **haematin**, which contains all the iron. A pure solution of haemoglobin can be obtained by centrifugalising defibrinated blood,¹ removing the serum with a pipette, shaking up the corpuscles with a 0.85 % sodium chloride solution² (which is nearly *isotonic* for the blood of the ox, horse, or man), and again centrifugalising.

By this means the corpuscles are thoroughly washed free of serum, etc. They are then collected and treated with two or three times their bulk of distilled water, in this the haemoglobin dissolves, a deep red solution resulting.

EXPERIMENT VIII. Heat carefully some haemoglobin solution. It decomposes at about 60° C., and the protein coagulates on further heating. Also test the solution for protein; it gives several of the ordinary protein reactions, but in each case a splitting into protein and haematin simultaneously ensues.

Besides being dissolved out by distilled water the haemoglobin may be set free from the red corpuscles by (i) warming to 50° C.; (ii) the addition of a little ether, or of dilute ammonia solution; (iii) the addition of bile, saponin, or the serum of another species of animal. The “laking” of blood can be recognised by the greater translucency of the laked blood (see also chapter on Haemolysis).

EXPERIMENT IX. Compare tubes of :—

- (a) whipped blood diluted with distilled water;
- (b) whipped blood diluted with physiological saline.

¹Horses' blood should be used for this purpose as the corpuscles sink more quickly than do the corpuscles of any other blood.

²A salt solution of this strength has the same osmotic pressure as the contents of the red blood corpuscle, and consequently no swelling or crenation of the corpuscle is produced.

That haemoglobin contains iron can be shown by the following experiment:—

EXPERIMENT X. Dissolve some dried blood by heating with strong nitric acid. Evaporate nearly to dryness in a dish. Dissolve in water and add potassium sulphocyanide solution. A blood-red colour indicates the presence of iron.

Crystals of haemoglobin.—These are most easily obtained from such animals as the rat or guinea-pig; with more difficulty from man and most other mammals.

EXPERIMENT XI. Mix a drop of rat's blood with a drop of water upon a slide. After several minutes examine under the microscope for haemoglobin crystals.

Haemoglobin, as we have seen, is a compound protein consisting of two parts, the iron containing portion "*haematin*" and the protein portion "*globin*." Haematin has the formula $C_{32}H_{32}N_4O_4Fe$. It itself does not crystallise, but a compound of haematin with hydrochloric acid and some other body (acetic acid, or an alcohol according to the method of preparation) called haemin can be obtained from haemoglobin, which crystallises in chocolate-brown rhombic plates. This forms one of the chemical tests for blood.

EXPERIMENT XII. *Preparation of Haemin Crystals.*—Place a drop of blood upon a glass slide and warm until dry. Scrape loose the brown residue, add a little glacial acetic acid, cover with a cover glass and warm very gently until bubbles form. Remove from flame. If necessary add a little more acid, and warm again till bubbles form. Repeat the operation two or three times. When cold examine with microscope for the dark-brown haemin crystals (Fig. 228).

There is sufficient chloride in blood to give the test without the addition of any sodium chloride. If, however, an old blood stain be used, it is necessary to add a small crystal of sodium chloride in case the chloride of the blood has been washed out. Bromide or iodide may be used instead of chloride, yielding a haemin with a corresponding change in composition.

Another chemical test for blood depends upon the fact that the iron containing portion of the haemoglobin will, in the presence of such oxidising agents as hydrogen peroxide, or old "ozonised" turpentine, convert a coloured body like tincture of guiac (red) to another coloured derivative (blue).

EXPERIMENT XIII. Boil some diluted blood. Add 2 drops of tincture of guiac (or of an alcoholic solution of guaiconic acid), then sufficient alcohol to dissolve the precipitate, and *lastly* a little ozonic ether, ozonic alcohol, or old oil of turpentine. A blue colour

is formed in the presence of blood. Ascertain in what dilution blood gives this test. Ozonic ether and alcohol contain hydrogen peroxide.

The solution is first boiled to destroy any oxidising enzymes present. These bodies can effect the same change, as also can many salts of metals, such as copper, iron, gold, cobalt, strong sodium chloride solution, and various other fluids such as milk, saliva, mucus, sweat,



FIG. 228—Haemin. $\times 1500$.

and juices of vegetable origin (extract of pea flour, fruit juices, etc.). If, however, the solution be first boiled, in the absence of metallic salts, the reaction is to be regarded as a reliable one for blood. In any case, if the test be *negative*, most investigators regard it as certain that *blood is absent*.

Other bodies such as aloin, benzidin, the leuco-base of malachite green and phenol-phthalin can take the place of guiac.

Aloin is said not to be so sensitive as guiac, benzidin is generally reported to be more sensitive, but according to Kastle the most sensitive is phenol-phthaline, with which he has detected 1 in 8,000,000 of blood.

EXPERIMENT XIII. *a.* To 1 c.c. of blood solution add 2 c.c. of phenol-phthaline and hydrogen peroxide reagent.¹ Note the purplish-pink colour which develops upon standing from 5 minutes to 1 hour. Ascertain in what degree of dilution a blood solution will give this test.

Another test for blood is the biological test (see chapter on Precipitins).

The function of haemoglobin is to carry oxygen to the tissues. This power of taking up oxygen can easily be demonstrated by shaking up venous blood with air (see under Spectroscope). The oxygen carrying capacity of blood can be ascertained as follows:—

EXPERIMENT XIV. In the bottle of a Dupré apparatus (see Fig. 242 in chapter on Urea) take 20 c.c. of oxygenated blood. Cover with dilute ammonia. In the small tube take 5 c.c. of fresh saturated potassium ferricyanide solution. Having adjusted the water to the zero of the apparatus by means of the clip—upset the ferricyanide into the blood. Shake well. Readjust the level of the water and read how much oxygen has been given off.

CHAPTER IX.

THE SPECTROSCOPIC EXAMINATION OF HAEMOGLOBIN AND ITS DERIVATIVES.

A SPECTROSCOPE consists essentially of a screen, in which there is a small *slit*, through which light from any desired source can pass, a *prism*, and a series of lenses forming the *telescope*, through which the observer looks.

For qualitative work the small direct vision spectroscope (Fig. 229) is serviceable. When the position of the bands, however, is required, one of the larger compound forms is necessary.

Adjustment of the Spectroscope.—It is necessary to have an exact focus of the image of the slit. In the *small direct vision spectroscope* this

¹ This reagent is prepared as follows:—Phenol-phthaline is added in excess (over .032 grms.) to 1 c.c. of $\frac{N}{10}$ NaHO. A little *redistilled* water is added. Shake well. Filter. To filtrate add 20 c.c. $\frac{N}{10}$ NaHO and make up to exactly 100 c.c. with redistilled water. Add .1 c.c. of 3% commercial H₂O₂. This solution is best kept in the dark. It may go faintly pink but not sufficiently to affect its value in testing for blood. Water redistilled from glass should be used, ordinary distilled water being distilled from copper. If this be used, the reagent will not keep (Kastle).

may be obtained by directing the instrument towards a white cloud, and moving the eye-piece till the various Fraunhofer lines are clearly defined, or, in absence of daylight, obtaining a clear image of the upper and lower edges of the slit, *i.e.* of the upper and lower edges of the spectrum. The slit should not be too widely open. If the source of light include a sodium flame, a clear image of the D-line will be obtained when the slit is in focus.



FIG. 229.—Small direct vision spectroscop.

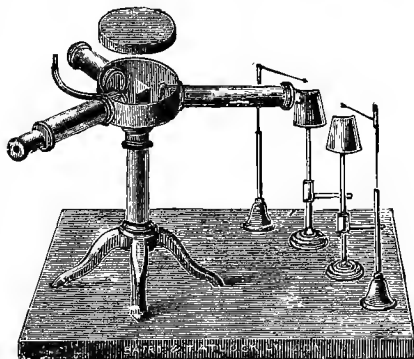

FIG. 230.—Compound spectroscop.

In the larger forms of spectroscop, three tubes are generally found radiating from the central prism or prisms¹ (Fig. 230). One of these has its end blocked by a screen, in which there is a slit where width can be varied by a small screw. Attached near to the slit there is generally a small prism, which can be moved so as to cover half the slit, and affords the means of introducing a second source of light into the instrument. The tube, at the end of which is the slit, is called the *collimator* tube, and contains a lens so that the image of the slit can be brought to bear on one face of the prism. The distance of the slit from the lens is variable, and should be adjusted so that the rays issue from tube into the prism as parallel rays. After refraction through the prism they are

¹For studying absorption spectra, the two-prism form with its greater dispersion of the spectrum is less well adapted.

collected by a second tube, *the telescope*, and the eye-piece of this should be arranged to receive parallel rays from the surface of the prism. The eye-piece is frequently fitted with cross wires, if so, the eye-piece should be first adjusted so that they are seen distinctly.

It will be found that the telescope has some lateral movement so that the vertical cross-wire can be made to coincide with any required part of the spectrum.

The third tube will contain a small scale which can be focussed on to the surface of the prism and will then become reflected along the axis of the telescope. It will be necessary first to adjust the movable end of the scale-tube so that the scale is in focus, and it may be necessary to move it laterally so that the scale is brought into the field of the telescope.

The scale must remain in a fixed position during any series of observations.

Construction of a chart for determining wave-lengths of bands on the spectrum.

With the scale in fixed position, notice the position on the scale of the sodium line, and the lines observable when the sodium flame is replaced by one coloured with a salt of strontium, calcium, lithium, barium, caesium, and potassium. Take observations of the positions of about twelve of these lines, the wave-lengths of which are known. Obtain the values corresponding to these wave-lengths, and on a piece of paper, ruled in squares, plot out their position, regarding the abscissae as degrees of the scale and the ordinates as wave-lengths. Draw a curve through the several points. The wave-length of any part of the spectrum can now be ascertained. Observe where such a part intersects the scale, follow the ordinate corresponding to the degree of the scale to the point of intersection with the curve, and a line parallel to the abscissae line will indicate the wave-length.

Having arranged the spectroscope so that the scale is illuminated and visible through the eye-piece, and the slit is illuminated by a light (an argand or incandescent burner) placed about one foot off; notice the position of the D-line on the scale. If sodium chloride be sprinkled into the illuminating flame, the D-line will be manifest, but a better method is to arrange between the illuminating flame and the slit a Bunsen flame in which asbestos soaked with a strong solution of sodium chloride is placed.

A piece of glass tubing about two feet long may be taken, which has the lower six inches bent back to form an angle of 60° with the main stem. This is filled with 6 p.c. solution of sodium chloride. The short arm is then plugged with asbestos. At the end of the long arm is a short piece of rubber tubing clamped fairly tightly. This tube is held by a burette clamp, and the projecting asbestos can be allowed to just touch the Bunsen flame. In this manner a constant D-line is furnished.

1. **The visible Spectrum of Oxyhaemoglobin.**—Take some defibrinated blood which has been thoroughly shaken with air, and dilute

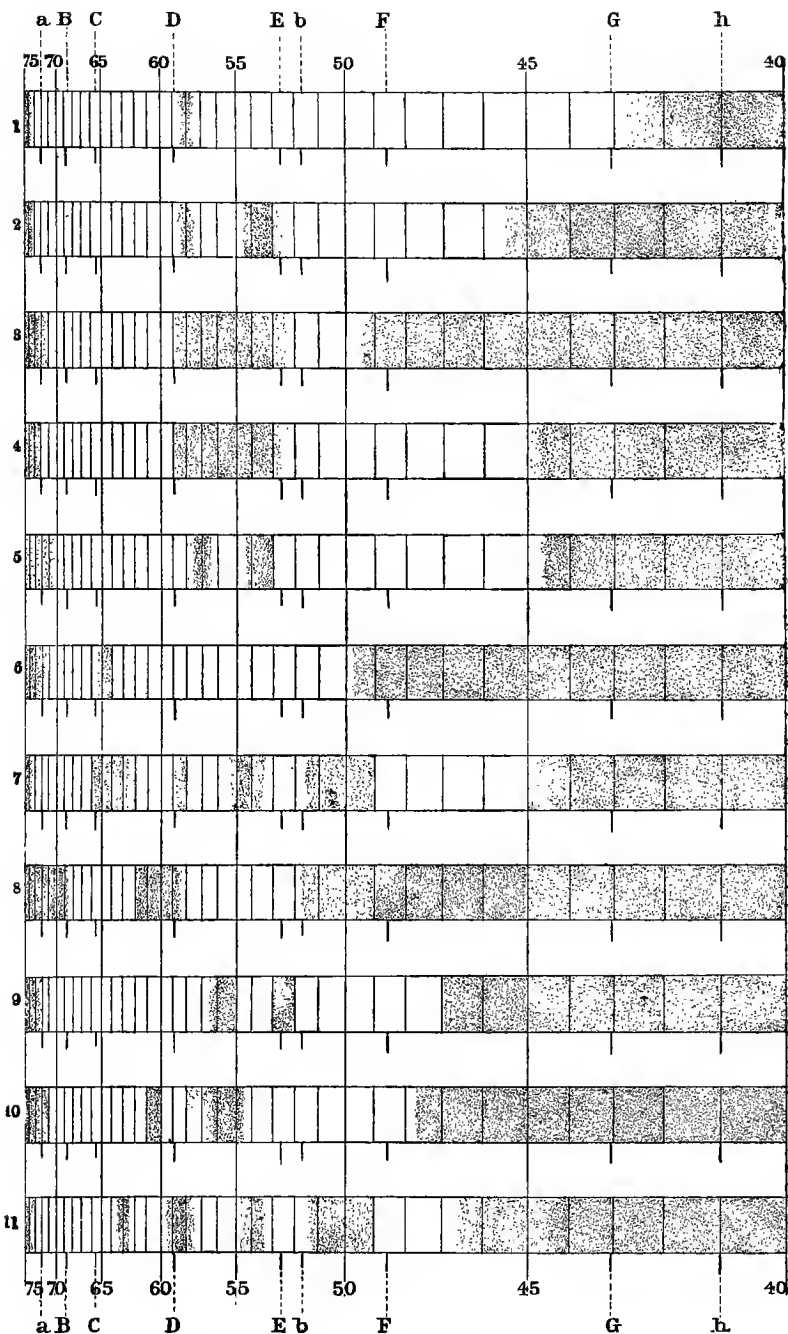

FIG. 2.1.—Absorption spectra.

1, Oxyhaemoglobin (very weak solution); 2, Oxyhaemoglobin (weak solution); 3, Oxyhaemoglobin (strong solution); 4, Haemoglobin (reduced haemoglobin); 5, Carbonmonoxide haemoglobin; 6, Acid haematin; 7, Acid haematin (etheral extract); 8, Alkaline haematin; 9, Haemochromogen (reduced haematin); 10, Haematoporphyrin (acid solution); 11, Haematoporphyrin (alkaline solution).

it with about ten times its volume of water. Place some of this behind the slit of the spectroscope, preferably in a flat-sided vessel about 1 cm. thick, but a test-tube will answer fairly well. It will be noticed that the whole of spectrum is blocked out except a portion of the red end.

Dilute this solution carefully. At a certain stage some of the green will be evident (see Spectrum 3 in Chart), there being a wide absorption band between the red and green. On diluting still further, this wide absorption band will resolve itself into two bands (Spectrum 2). These two bands are both on the blue side of the D-line, and their centres correspond to λ 579 and λ 543.8. Note carefully the position of these centres on the scale and the width of the bands. Observe also the limits of the visible spectrum at the red and blue ends.

On diluting still further it may be possible to cause the band on the blue side to disappear, whilst the band on red side is still just appreciable (Spectrum 1).

2. **The visible Spectrum of Haemoglobin (reduced Haemoglobin).**—If some diluted defibrinated blood be left standing undisturbed for 24 hours, the oxyhaemoglobin will lose its oxygen. This result may be arrived at more rapidly by treating some diluted defibrinated blood which shows fairly wide oxyhaemoglobin bands with a reducing reagent, such as ammonium sulphide or Stokes' reducing fluid.¹ If ammonium sulphide be used, the mixture should be warmed. It will now be noticed that the blood loses its bright scarlet appearance and becomes more purple in tint. Examine this by the spectroscope, and it will be found that the two bands of oxyhaemoglobin have disappeared, and are replaced by one band, the centre of which is between the two bands of oxyhaemoglobin. The band is a broad one, shading off more gradually on the red side, and the darkest part corresponds in wave-length to λ 550 (Spectrum 4 in Chart).

3. **The visible Spectrum of Carbon-Monoxide Haemoglobin.**—If a stream of carbon monoxide, or even of coal-gas, be passed through some diluted defibrinated blood, the scarlet tint is changed to a carmine or cherry colour. The oxygen is replaced by carbon monoxide. Examined spectroscopically the blood shows two bands differing from those of oxyhaemoglobin in being slightly shifted towards the blue end. The two bands have centres corresponding in wave-length to λ 575 and λ 540 approximately (Spectrum 5).

The proportion of red and blue unabsorbed at the ends of the spectrum is different in oxyhaemoglobin and CO-haemoglobin, there being more

¹ 2 gms. of ferrous sulphate are dissolved with 3 gms. tartaric acid in 100 cc. of water. Ammonia is added till the solution is alkaline. Stokes' fluid must be freshly prepared.

blue unabsorbed in CO-haemoglobin than in the former. Hence, comparing dilute solutions of similar strength in test tubes of the same diameter, the CO-haemoglobin has a distinct bluish tinge, contrasting markedly with the yellowish-red of the oxyhaemoglobin. This difference of end-absorption can be best shown as follows: Take a fairly dilute solution of oxyhaemoglobin showing the two characteristic bands clearly, but not strong enough to produce any intermediate shading. Note as carefully as possible where the red and blue are first visible. Pass a stream of coal gas or carbon monoxide through the solution by means of a fine nozzle for two or three minutes. Note the change in colour produced, and again examine the spectrum. It will now be found that rather more of the blue is visible, whilst the red is unaltered or slightly more absorbed.

An important difference between oxyhaemoglobin and CO-haemoglobin is seen in the effect of reducing reagents. If CO-haemoglobin be treated with Stokes' fluid or ammonium sulphide, it is unchanged.

4. **The visible Spectrum of Methaemoglobin.**—To a solution of oxyhaemoglobin, in which the two bands are so wide as to partially overlap, add a few drops of a strong solution of potassium ferricyanide. The colour changes to a chocolate tint. If this be spectroscopically examined, a distinct band is seen on the red side of the D-line, the wave-length of its centre being about λ 635 (Spectrum 12). On diluting the solution down, other bands may be seen—one just on the blue side of the D-line (λ 581), another still further towards the blue (λ 540), and a fourth may be made out on the bluish-green (λ 500) (Spectra 13 and 14). The two middle bands are probably not due to any traces of oxyhaemoglobin, but are characteristic of methaemoglobin.

If such a solution of methaemoglobin be treated with ammonium sulphide, a transient spectrum of oxyhaemoglobin may be seen, succeeded by a permanent spectrum of reduced haemoglobin.

If the solution of methaemoglobin be rendered alkaline with ammonia, the colour changes to a more distinct red, and the absorption band in the red disappears and is replaced by a band immediately on the red side of the D-line (Spectrum 15 in Chart).

By the action of nitric oxide on oxyhaemoglobin, a product is formed called **nitric oxide haemoglobin**. This is characterised by two bands, which are between the D and E-lines: the band on the red side is somewhat nearer the red end than the corresponding band of oxyhaemoglobin (Spectrum 16).

If oxyhaemoglobin be treated with a nitrite, as sodium nitrite or

amyl nitrite,¹ there is formed a certain amount of methaemoglobin and a certain amount of nitric oxide haemoglobin. The combination of the two gives a spectrum very similar to simple methaemoglobin (Spectrum 17 in Chart).

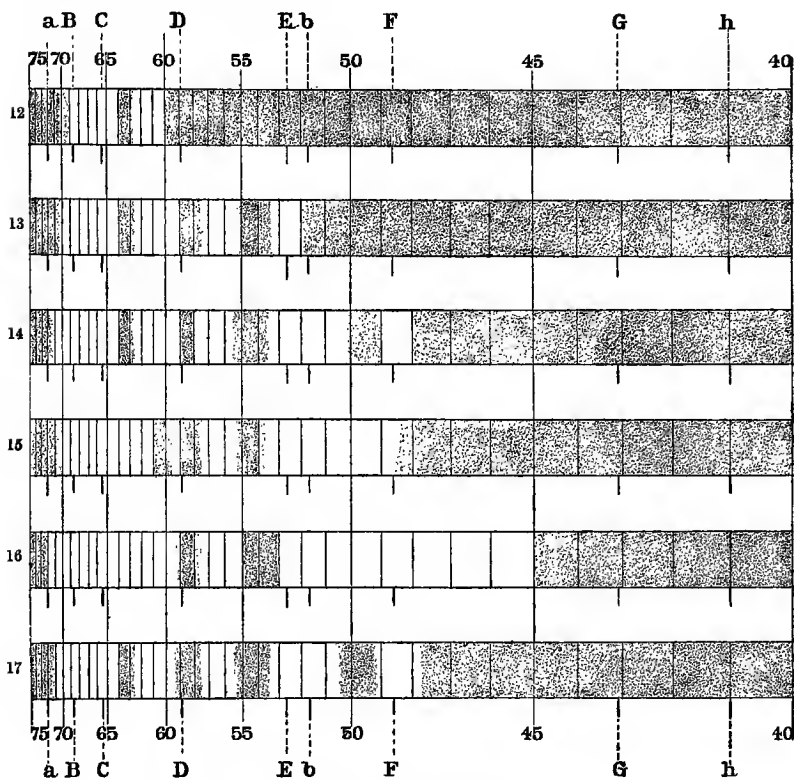

FIG. 232.—Absorption-spectra.

12, Methaemoglobin (strong solution); 13 and 14, Methaemoglobin (weak solutions); 15, Methaemoglobin (alkaline solution); 16, Nitric oxide haemoglobin; 17, Mixture of Methaemoglobin and nitric oxide haemoglobin.

If the product of the action of nitrites be treated with ammonium sulphide, the spectrum passes through a transient oxyhaemoglobin stage, succeeded by reduced haemoglobin, and later becomes nitric oxide haemoglobin.

5. **The visible Spectrum of Acid-haematin.**—If some diluted defibrinated blood be treated with a little glacial acetic acid and gently warmed, it will assume a dark brown colour. If it be diluted suffi-

¹Care must be taken to avoid excess of amyl nitrite, or so-called photo-methaemoglobin, characterised by one broad band between D and E, will be formed.

ciently, and examined spectroscopically, it will present a spectrum characterised by one band on the red, the wave-length corresponding approximately to $\lambda 645$. The blue end of the spectrum will be very largely absorbed (Spectrum 6 in Chart).

There is frequently a considerable amount of general absorption in the acid-haematin prepared as above, and the band referred to may only be made clear by filtering the solution. More satisfactory results are obtained by extracting the colouring matter with ether, or treating with chloroform and excess of acetic acid, as follows:—

(a) Take defibrinated blood, and add about half its volume of glacial acetic acid and about an equal quantity of ether. Shake at once. The ether will extract the colouring matter, and, on examining the same spectroscopically, three distinct bands will be seen—one on the red similar to that already described, but apparently shifted nearer the D-line ($\lambda 640$), one on the green ($\lambda 550$), another on the green but nearer the blue ($\lambda 515$). A very indistinct band may be seen on the yellow ($\lambda 590$) (Spectrum 7 in Chart).

(b) Take defibrinated blood, warm and add half its volume of glacial acetic acid. Cool and add half the volume of chloroform, and more acetic acid if any precipitate appears. The solution will become clear and give a spectrum similar to that shown in the ethereal extract.

6. **The visible Spectrum of Alkaline Haematin.**—Take some diluted defibrinated blood, and add a few drops of strong caustic soda, and warm. The colour will change to a greenish-brown tint, and when the solution is examined spectroscopically, it will show a single band on the orange (wave-length, $\lambda 600$). A more satisfactory method of preparing the alkaline haematin is to form a paste of potassium carbonate and defibrinated blood; dry it over a water-bath and extract with alcohol, when a reddish-brown solution is obtained which shows the distinguishing absorption band clearly (Spectrum 8 in Chart).

7. **The visible Spectrum of Haemochromogen (reduced Haematin).**—If a watery solution of alkaline haematin be warmed with a few drops of ammonium sulphide, the brownish colour is replaced by a more marked red. If the solution be examined spectroscopically, the one band of alkaline haematin is found to be replaced by two bands on the green, the wave-lengths of their centres being approximately $\lambda 557$ and $\lambda 525$ (Spectrum 9).

8. **The visible Spectrum of Haematoporphyrin.**—Take some strong sulphuric acid (10 c.c.) in a test tube and add a few drops of blood, and shake up the mixture. A purple colour will result, due to the decomposition of the haemoglobin and the formation of the iron-free pigment, haematoporphyrin. This examined spectroscopically will, in the above

acid solution, show two bands, the centres being approximately λ 605 and λ 565 (Spectrum 10 in Chart).

If a large excess of water is added to the above a precipitate is thrown down. If this be dissolved in a little caustic soda, a solution of haematoporphyrin in an alkaline medium is obtained, which shows a four-banded spectrum when examined, the positions of the bands being λ 630, λ 580, λ 550, and λ 520 approximately (Spectrum 11 in Chart).

Haematoporphyrin may be regarded as iron-free haematin, and identical in composition with bilirubin. The following equation represents the change brought about by sulphuric acid:—

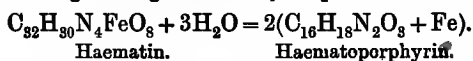

Solutions of haematoporphyrin exhibit a red fluorescence. This pigment must be regarded as normally present in small quantities in urine.

CHAPTER X.

MUSCLE.

MUSCLE forms the most abundant tissue in the body. It is here that a great part of the food-stuffs undergo combustion, as a result of which energy is liberated and appears either as a muscular movement or as heat. The food-stuffs, along with the oxygen necessary for their combustion, are carried by the blood to the muscle, and the effete products are removed by the blood coming from the muscle.

Muscle also constitutes one of the commonest food-stuffs, meat being the form in which we take much of our protein and a considerable amount of our fat (see chapter on Food).

The Chemical Composition of Muscle.

Water, - - - - -	75 per cent.
Proteins, - - - - -	20-21 „
Organic Extractives, - - - - -	0·3-·4 „
Fat, - - - - -	2-3 „
Inorganic Salts, - - - - -	1·0-1·3 „

The Proteins.—To study these we require a muscle extract.

Preparation of Muscle Extract.—A rabbit is killed, and a cannula tied into its aorta, by which the blood-vessels are washed free of blood. The muscles are then removed and quickly passed through the mincing

machine. The mince is mixed with a 5% solution of magnesium sulphate, the mixture being placed on ice and left standing all night.

Divide some of the extract provided into two parts, *a* and *b*.

EXPERIMENT I. (*a*) Dilute with four volumes of water, and place in the water-bath at body temperature. A clot forms, leaving *muscle serum*.

(*b*) Add some acetic acid. A precipitate forms. Filter. Neutralise the filtrate with Na_2CO_3 solution, and dilute it with water. Place it in the water-bath at 37°C ., and note that no coagulum forms.

These two experiments show us that the extract contains in solution a substance which is precipitated by acetic acid, and which becomes transformed into an insoluble clot under suitable conditions. This body is protein in nature. Prove this by dissolving the clot in (*a*) in 10% sodium chloride and applying the protein tests. The soluble body is called *myosinogen*, and the clot *myosin*.

Besides myosinogen the extract contains, however, other proteins.

EXPERIMENT II. Take some of the muscle serum in (*a*), or of the filtrate in (*b*), and half saturate with ammonium sulphate. A precipitate of *globulin* results. Filter off this globulin and test the filtrate for *albumin* by full saturation with Am_2SO_4 , or by coagulation by heat after faintly acidifying.

EXPERIMENT III. Use the saline extract of muscle provided. Heat 5 c.c. carefully in a test tube in the water-bath. Note the temperature of the first signs of coagulation. Filter off coagulum and heat the filtrate, noting the temperature at which the flocculi of a second coagulum appear. It will be found that the first protein (paramyosinogen, also termed myosin) is coagulated at 47°C ; the second protein (myosinogen, also called myogen) at 56°C .

Both these bodies serve as the source of the coagulated myosin in muscle. In the clotting associated with rigor mortis it is stated that paramyosinogen is converted directly into myosin; whereas myosinogen is first converted into a soluble form (soluble myosin), which is then turned into insoluble myosin. Soluble myosin can be identified by its low-heat coagulation point (40°C).

The coagulation points of the chief proteins of frog's muscle have already been graphically studied (see Heat Rigor, p. 34.)

EXPERIMENT IV. Show that the *watery* extract of muscle provided contains less protein than the saline extract. It contains albumin, but not globulin. Demonstrate this fact. Coagulate the albumin by heat, and save the filtrate to test for phosphates later.

Organic Extractives. These are organic substances which are soluble in water, but not protein in nature. They may be divided into two

classes, (a) nitrogenous, (b) non-nitrogenous. The chief members of the first group are creatin ($C_4H_9N_3O_2$), and the purin bodies hypoxanthin ($C_5H_4N_4O$) and xanthin ($C_5H_4N_4O_2$). The most important non-nitrogenous extractive is sarcolactic acid ($C_3H_6O_3$).

Creatin is the most abundant extractive in muscle, amounting to .4 - .45 % in rabbits, .3 % in bullocks, .26 % in frogs, and .2 % in hedgehogs. Chemically it is closely related to urea, and can be changed into this body and a substance called sarcosin by boiling with baryta water.

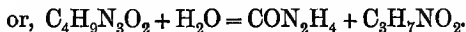
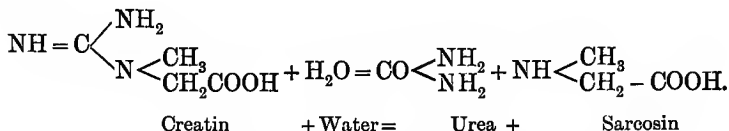

Although this reaction takes place outside the body, there is no evidence that such is the fate of creatin in the body, although many attempts have been made to prove that such is the case. Injection of creatin into the body leads to no increase in the formation of urea of the body.

Another interesting relationship of creatin is to the substance called *creatinin*. If creatin be boiled with dilute mineral acids it loses a molecule of water and becomes changed into creatinin.

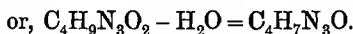
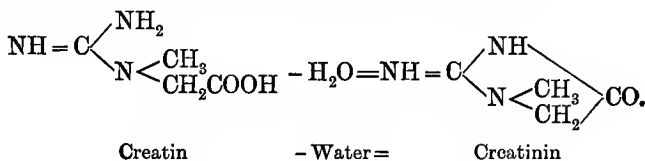

This reaction is the best means of recognising creatin, since it gives no characteristic tests, whereas creatinin does.

EXPERIMENT V. Take about 10 grammes of fresh muscle, grind with alcohol, filter, evaporate at about 50° C. Dissolve in water and divide into two equal portions, *a* and *b*. To *a* add 15 c.c. of saturated picric acid solution and 5 c.c. of 10 % caustic soda. Allow to stand 5' and dilute to 500 c.c. Note that there is no change in the colour of the solution, therefore creatinin is absent. To *b* add half its volume of N. HCl and heat in a flask fitted with a cork and glass tube to act as air condenser on water-bath for five hours. Neutralise with caustic soda, add picric acid solution and caustic soda, and dilute as before.

Note *red* colour, due to picramic acid. *Creatinin is now present.* (For other tests for creatinin see chapter on Urine.)

The exact relationship of creatin to creatinin in the body is still a matter of doubt. It was thought at one time that the creatin of the muscles gave rise to the creatinin of the urine. This now appears not to be the case, since creatinin is never present in muscle even after very prolonged muscular exercise. The amount of creatinin in the urine is extremely constant under all conditions, and it is therefore regarded by Folin as a measure of the endogenous metabolism of the body. Whence it arises is not certain, but the recent work of Mellanby points to the fact that creatinin is formed in the liver from unknown precursors. From the creatinin thus formed the creatin supply of the body is replenished, and the creatinin that is not wanted is excreted by the kidney in the urine. We thus see that creatinin probably gives rise to the creatin of the body, and not the creatin to the creatinin. Further work is required to amplify these facts and also to find out the fate of creatin in the body, which is at present unknown. Recently Cathcart has pointed out that creatin, which does not normally appear in the urine, is present when the carbohydrate supply of the body is cut off. (See also small print at end of chapter.)

Hypoxanthin and Xanthin. These are members of the group of bodies known as the purin bodies. They are thus termed because the so-called purin ring

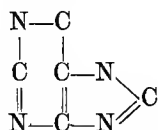

is the basis of their constitution, purin itself, a synthetic body being

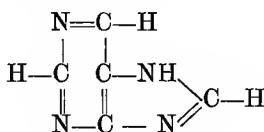

or more simply $\text{C}_5\text{H}_4\text{N}_4$

Hypoxanthin is monoxypurin, and is represented by the formula

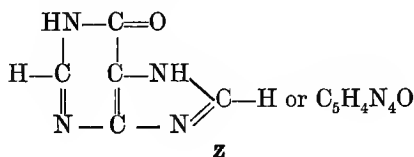

Xanthin is dioxypurin :

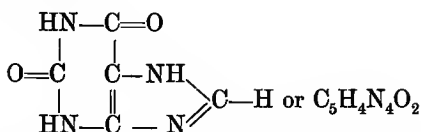

Lastly trioxypurin, which occurs in muscle only in traces, is *uric acid*, $\text{C}_5\text{H}_4\text{N}_4\text{O}_3$. (See Chapter XVIII. p. 422.)

Hypoxanthin and xanthin result in part from the breakdown of the nuclein present in the muscle, but their amount is normally so large compared to the amount of nuclein present that this cannot be their sole source; the other source of supply is at present unknown. It is probable that they normally give rise to uric acid, since it is found that some time after muscular exercise the uric acid output of the urine is considerably increased. (For the isolation of these bodies from muscle extract see end of chapter.)

Lactic Acid ($\text{C}_3\text{H}_6\text{O}_3$). This variety of lactic acid differs from that obtained by the fermentation of lactose, which does not rotate the plane of polarised light. The lactic acid of muscle, often termed *sarcoplactic acid*, rotates the plane of polarised light to the right. This behaviour depends upon a difference in position of the various side chains in relation to the central carbon atom. (Cf. carbohydrates, p. 280.) The amount of lactic acid increases very much during the death of a muscle, and also during muscular activity. These points can be shown by the following experiments :

(a) To some of Uffelmann's reagent (a mixture of ferric chloride and carbolic acid) add some of the muscle extract provided. This probably contains lactic acid from the dying muscle; if it does the violet colour of Uffelmann's reagent will be turned to yellow by the lactic acid present.

(b) *Hopkins' Test for Lactic Acid.* Take about 5 c.c. of strong sulphuric acid in a dry test tube, add 1 or 2 drops of a solution of muscle extract, 2 or 3 drops of saturated solution of copper sulphate. Warm in boiling water for about two minutes; cool and add a few drops of alcoholic thiophene solution (20 minims in 100 c.c. alcohol), and warm gently. With lactic acid a cherry red colour develops.

(c) Take a pithed frog which has been kept on ice for half an hour. Quickly cut off the muscles of one hind limb; cut off the other limb at the pelvic girdle, and stimulate electrically until irritability is nearly lost. Cut off the muscles. Treat both sets of muscles as follows: Grind with cold absolute alcohol and sand, filter, evaporate the alcohol, dissolve in water, heat with a little animal charcoal, filter, evaporate, and

apply the thiophene test. It will be found that the muscles of the tetanized limb give a positive reaction; those of the non-tetanised do not. The tetanised limb having no circulation was poorly supplied with oxygen. If it had been kept in an atmosphere of oxygen, the lactic acid formed on tetanisation would have rapidly disappeared, so that fatigue would have developed more slowly, and would have disappeared rapidly on keeping the limb at rest in the oxygen of the ordinary room temperature (Fletcher and Hopkins). The explanation is that with plenty of oxygen any lactic acid formed is rapidly destroyed with the evolution of carbon dioxide. With an intact circulation lactic acid is certainly formed in the muscles with even short periods of violent exercise, since Ryffel has shown that under these conditions lactic acid is present in increased amount in the urine. This being the case it is probable that the formation of this acid is one of the causes leading to the hyperpnoea which attends hard muscular exercise (see page 459).

Another important nitrogen-free extractive is **glycogen** ($C_6H_{10}O_5$) $_n$. The relative amount of this is small (0.5 to 1%), but it varies in different animals, and is much diminished after muscular activity. Although the percentage is small the *total* amount contained in all the muscles of the body has been found, in the case of the cat at least, to be nearly the same as that contained in the liver.

The less important extractives are: **Urea**, **carnic acid** ($C_{10}H_{15}N_3O_5$) (which exists in muscle combined with phosphoric acid as phospho-carnic acid), **dextrose** (trace), **inosite** (hexahydroxybenzene), and **lecithin**.

Carnic Acid.—If a weak solution of ferric chloride be added to a muscle extract (from which the proteins have been removed by boiling and the phosphates by the addition of calcium chloride and ammonia) a brown precipitate is obtained. This is called *Carniferrin*, and consists of the iron salt of phospho-carnic acid. If, further, the phosphoric acid and iron be split off from this we obtain carnic acid, and this, curiously enough, has the same formula as, and gives nearly all the reactions of, one of the varieties of peptone known as anti-peptone.

Inorganic Salts.—These consist of salts of the alkalies and alkaline earths. The chief acid radicle present is *phosphoric acid*, and this exists in several states—(a) Inorganic phosphates, (b) phosphorus of lecithin, (c) phosphorus of nuclein, (d) phosphorus of phospho-carnic acid, (e) besides these the watery extract contains another phosphorus-containing organic compound of unknown composition.

Phosphorus, therefore, seems to be a very important constituent of muscle, and its form of combination changes after muscular work, the organically combined phosphorus being split off as inorganic phosphates

which are then washed out of the muscle by the blood, and appear in the urine. It is on this account that the phosphates in the urine are increased after muscular work.

EXPERIMENT VI. The watery extract of muscle has been freed of proteins by boiling it. Add to the clear filtrate an ammoniacal solution of magnesium citrate. A white precipitate of phosphates results.

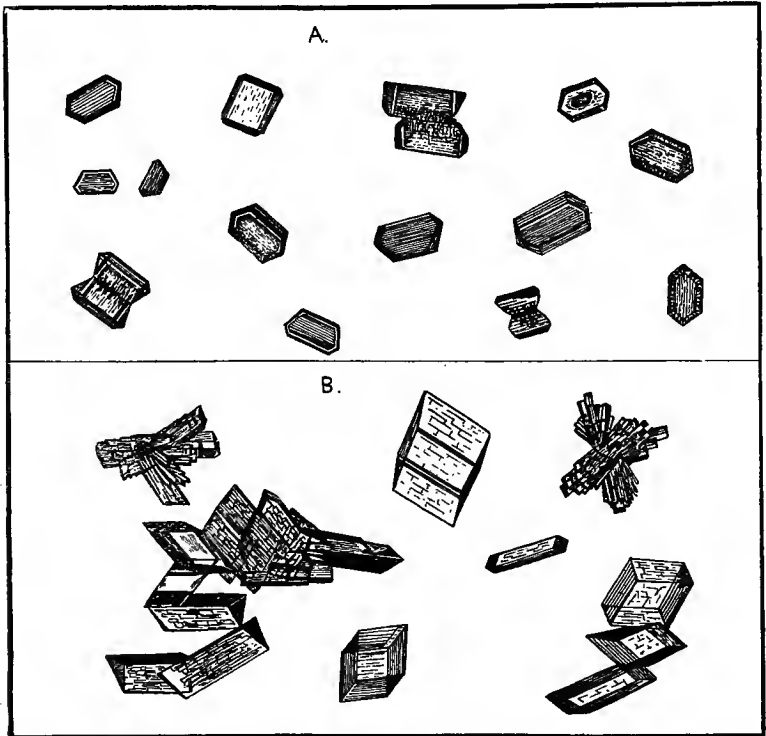

FIG. 233.—Crystals obtained from meat extract, mostly creatin, a few sodium chloride.

Show that this precipitate consists of phosphates by dissolving it in nitric acid and testing with ammonium molybdate.

EXPERIMENT VII. As a general revision experiment test the solution of commercial extract of meat provided for proteins, glycogen, creatin, creatinin, mineral salts, etc.

Preparation of Extractives of Muscle.—500 grammes of meat, from which as much fat and tendon as possible have been removed, are finely minced; the mince is thoroughly mixed with 500 c.c. of water and heated for half an hour on a water-bath at C. The extract is strained through muslin and the residue extracted several times in a similar manner, the extracts being mixed together.

The protein in the extract is then coagulated by boiling, and, after cooling, the coagulum removed by filtration.

A similar extract may be prepared by dissolving some commercial meat extract in water.¹

To remove the phosphates and the last traces of proteins from this extract a saturated solution of subacetate of lead is added to it until no more precipitate is produced. (Care should be taken that an excess of the subacetate solution is not added. This may be ascertained by filtering samples of the extract and seeing if these yield further precipitates with the subacetate solution.) The precipitate thus obtained is removed by filtration.

The excess of lead is precipitated from the filtrate by passing a current of sulphuretted hydrogen through it. The precipitate of lead sulphide is removed by filtration. The filtrate is then evaporated to small bulk (any sulphur which may separate out being removed by filtration) and allowed to stand on ice for two or three days, when a large number of oblique rhombic crystals of creatin will have separated out. (See Fig. 233.) These are collected on a filter (for which purpose a suction pump will be found necessary) and are thoroughly washed with alcohol until no more pigment is removed. The filtrate is preserved for the isolation of the other extractives.

Xanthin and Hypoxanthin.—The creatin-free filtrate is made strongly alkaline with ammonia, and is then mixed with ammoniacal solution of silver nitrate. The purin bodies are thus precipitated. The precipitate is collected on a filter paper and thoroughly washed with dilute ammonia, and the hypoxanthin and xanthin are separated from it by the following method: the precipitate is removed from the filter paper and dissolved in boiling nitric acid (spec. grav. 1.1), a few crystals of urea being added to the solution so as to destroy any nitrous acid which may be present, and which would decompose the purin bodies. When all the precipitate has dissolved the solution is quickly filtered hot, and the filtrate is allowed to stand over night, when it will be found that a precipitate consisting of fine needle-shaped crystals (Fig. 234) has separated out. This consists of hypoxanthin silver nitrate combined with nitric acid; to remove the nitric acid wash it with distilled water, transfer it from the filter to a small beaker and boil it with ammonia until the crystals break up and become amorphous, and then, to remove the silver, pass in H_2S , filter off the silver sulphide, and evaporate the filtrate slowly to dryness, when a white chalk-like mass of *hypoxanthin* will be obtained. In order to obtain the xanthin silver salt the filtrate from hypoxanthin should be treated with ammonia, when a few yellow flakes of the salt will be obtained. To separate the *xanthin* this precipitate is treated in exactly the same way as for hypoxanthin.

Test for Hypoxanthin.—Place a piece of hypoxanthin in a small evaporating dish with a few drops of concentrated pure nitric acid and evaporate slowly to dryness: a brilliant yellow residue is obtained. Cool, and then add a drop of sodium hydrate solution, when the residue will change to orange. If the residue be dissolved in water and the solution again evaporated to dryness the orange

¹The following amounts are suitable for this preparation: Ten grm. bovril are dissolved in 200 c.c. water, and to this is slowly added 60 c.c. of a saturated solution of subacetate of lead. After the precipitate has settled down a sample of the supernatant fluid is removed by a pipette to a test tube and tested with the subacetate solution to be certain that no more precipitate is produced.

colour persists, thus differing from the murexide stain which, when similarly treated, loses its colour (see p. 425).

Test for Xanthin.—Repeat the same test as for hypoxanthin and note that the sodium hydrate produces in this case a deep red colour, which persists on dissolving in water and evaporating.

Sarcolactic Acid.—The ammoniacal filtrate, from which the alloxuric bodies have been separated, is treated with sulphuretted hydrogen gas so as to remove the silver which it contains: the silver sulphide is filtered off, and the filtrate

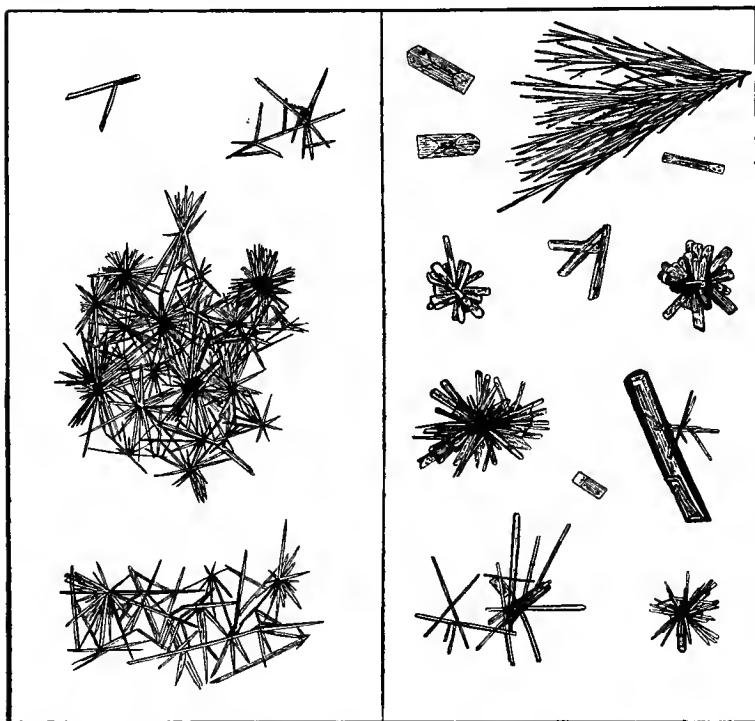

FIG. 234.—Hypoxanthin silver nitrate. $\times 300$.

FIG. 235.—Zinc sarcolactate. $\times 300$.

evaporated till all the ammonia has been expelled. It is then made strongly acid with phosphoric acid, and the lactic acid, which is hereby liberated, is dissolved out by shaking it in a separating funnel with ether.

After extracting three or four times, the ethereal extracts are combined and the ether evaporated away by placing on a water bath heated to about 60°C ., the flame underneath which has been extinguished. An acid syrup remains behind; this is impure lactic acid. In order to purify it, dilute three times with water, bring the resulting solution to the boil, and then carefully add powdered zinc carbonate until the reaction is neutral. Filter. Evaporate the filtrate to small bulk, and add an equal bulk of spirit and allow to stand, when *zinc sarcolactate*

will crystallise out (Fig. 235). The zinc salt is filtered off, washed several times with spirit, dissolved in water,¹ and the zinc separated by passing a stream of sulphuretted hydrogen through the solution. The zinc-free filtrate is then freed of water by evaporation, when the *lactic acid* is obtained as a syrup.

CHAPTER XI.

DIETETICS, FOOD, METABOLISM.

FOOD is taken into the body for two purposes—(1) to replace tissue waste ; (2) to supply energy for work and for heat.

It is necessary that such food should be taken in a proper amount, in a digestible form, and adapted to the climatic circumstances and occupation of the eater. It is also essential that the food should be as varied as possible, for experience shows that an unvaried diet is not eaten with relish and may impair the general health and resistance to disease. The appetite of a healthy man is the best guide for the selection of his food ; it is the expression of physiological needs which have not been investigated sufficiently to justify dogmatic statements as to what a man should and should not eat.

We may, therefore, divide the proximate principles² of food into two groups, viz. :

Tissue formers—Protein, inorganic salts, water.

Combustion material—Protein, fats, carbohydrates.

It will be observed that, of the organic food stuffs, protein may act in either capacity, and hence, that a diet containing protein and salts alone can serve as an efficient food. That this is so is proved by the fact that the Indians of the Pampas live entirely on flesh. Without protein it is impossible to maintain life ; but if more than is necessary for the repair of the broken-down tissues be supplied, the excess serves as a fuel.

The most serviceable combustion material seems, however, to be carbohydrate ; next comes protein, and the least available is fat, this latter being pre-eminently the form in which the excess of food over

¹The watery solution should be evaporated until the crystals of zinc sarcoc-lactate begin to appear, this being ascertained by examining a drop under the microscope.

²These nutritive constituents are called the *proximate principles* of food, because, consisting as they do of carbon, hydrogen, oxygen, and nitrogen combined into highly complex bodies, they are really elementary constituents of the organism.

present requirements is laid by for future use. Thus, during summer, hibernating animals store up a large quantity of fat, and this is called upon during the winter sleep to furnish the energy necessary for life.

In judging whether any diet be efficient the first thing we must determine, therefore, is whether it contains a sufficient amount and a suitable mixture of the nutritive constituents of food. In practice it is found that these facts can be determined by estimating the amount of *carbon* and of *nitrogen* which the diet contains. We can find out how much of these two elements is necessary by estimating the amount of them contained in the excreta.

An ordinary man under ordinary circumstances eliminates about 300 grammes of carbon per diem (chiefly as carbon dioxide), and about 15 grammes of nitrogen (chiefly as urea, etc., in the urine). Now, the only food-stuff which contains both these elements is protein, and to supply the required amount of nitrogen it would be necessary to give only about 100 grammes of this. Such an amount would, however, only furnish about one-sixth of the necessary amount of carbon. This difficulty could be surmounted by giving about 600 grammes of protein, but then the tissues would be supplied with six times more nitrogen than they required. It is advantageous, therefore, to mix with the protein some food stuff containing an excess of carbon, but no nitrogen. Such a food stuff is fat or carbohydrate. Experience teaches us that of these two the more serviceable is carbohydrate, and for two reasons: firstly, because it is more easily digested; and, secondly, because it is cheaper.

When muscular work is performed the excretion of carbon rises, whereas that of nitrogen is scarcely affected at all, so that in such cases the diet should contain an abundance of carbon.

Another method of determining how much food will be required, is to estimate *how much energy* must be liberated in order to meet the needs of the organism. We can do this by placing the person in a respiration-calorimeter in which all the actual heat which leaves the body is collected and measured. By adding this result to the thermal equivalent of the muscular work which he meanwhile performs, we obtain the total amount of energy eliminated. This result is expressed in calories, a kilo-calorie being the amount of heat necessary to raise the temperature of one kilo of water through one degree centigrade. In this way it is found that about 3,500 kilo-calories are necessary per diem for an adult doing ordinary work.¹

¹In physical chemistry the unit of heat chosen is one thousand times smaller than the physiological Calorie, it being in this case the amount of heat necessary to raise the temperature of one gramme of water through one degree centigrade.

Having determined how much energy will be required, we must now find out how much food must be supplied to yield it. We can determine the caloric value of the various food-stuffs by burning them in a chemical calorimeter. Since the end products of the combustion of fats and carbohydrates (*viz.*, CO_2 and H_2O) are the same in the body as *in vitro*, their physical caloric values for 1 grm. of the dry substances are the same as their physiological, *viz.*, 4.1 for carbohydrates and 9.3 for fats. A very important end product of the metabolism of protein is, however, urea, which still contains some potential energy, so that it has a physical heat value of its own. In order to find the physiological heat value of protein, therefore, we must deduct from its physical value the physical value of the amount of urea arising from it. By this means it has been shown that the physiological heat value of protein is practically the same as that of carbohydrate, *viz.* 4.1.

By an examination of the diets taken by various classes of people, averages of the relative amounts of the various classes of food-stuffs have been obtained. Such a table for a man doing an ordinary amount of work is the following:

Protein,	125 grammes. ¹
Carbohydrate,	500 grammes.
Fat,	50 grammes.

This diet yields:

	Carbon.	Nitrogen.	Kilo-Calories.
Protein,	62 grm.	20 grm.	$125 \times 4.1 = 512.5 \text{ C.}$
Carbohydrate,	200 grm.	—	$500 \times 4.1 = 2050 \text{ C.}$
Fat,	38 grm.	—	$50 \times 9.3 = 465 \text{ C.}$
Total,	300 grm.	20 grm.	3027.5 C.

Such a diet is represented approximately by: $\frac{1}{2}$ lb. prime lean meat; $1\frac{1}{2}$ lbs. bread; 2 oz. butter; $\frac{1}{2}$ pint milk; 1 lb. potatoes; and $\frac{1}{4}$ lb. oatmeal.

Demonstration.—The quantities of foods given above have been

The small calorie is written with a small "c," the large one with a capital "C." The heat unit can be transformed into units of work by multiplying by 425.5, a unit of work being expressed as the amount of force necessary to raise a weight of one gramme to a height of one metre—a gramme metre—or of one kilogramme to the same height, a kilogramme metre.

¹ Dryweight.

weighed out. Carefully gauge the amounts so as to gain an idea of the food necessary daily for a person doing *light muscular* work.

For persons leading a sedentary life only 2,500 to 2,700 calories are required. For moderately hard muscular work it is well to allow 3,300—3,700 C., for hard and very hard muscular work from 4,150—5,000 C. are required. Specimen diets are given in the following table:

	Protein.	Fat.	Carbohydrate.	Calories.
Sedentary, - -	88	108	345	2,501
Moderate hard work, -	{ 125	137	476	3,364
	{ 116	158	538	3,762
Very hard work, - -	{ 145	195	557	4,223
	{ 145	235	666	4,954

Most investigators have given diets fairly closely resembling these; and although some of them include more fat than the specimen diet we have taken, it must be remembered that fat is considerably dearer as an article of food.

Chittenden, as the result of his experiments, believes that the body is better with a low protein diet that is considerably less than those given above. It has recently been shown, however, that the constituent parts of the protein vary considerably in their value for the maintenance of health. The ringed amino-acids (tyrosin, tryptophan, etc.) appear to be the most important. Bodies without these, such as gelatine, cannot support life. Yet if these bodies be added to gelatine or other such inadequate diet (*e.g.* the products of digestion not containing the benzene ring), such addition renders the diet adequate. It is worthy of note, also, that the diet supplied to the young animal contains much protein (caseinogen), rich in such "ringed" bodies. The kind of protein in a diet must, on this account, be taken into account. It would seem therefore that it is well, as the analyses of the diets of different nations show, to have about 125 grammes of protein in a diet in order to ensure an adequate supply of substances from which the organism can select what is needed for its nutrition.

These facts, too, show us how important it is to know the exact composition of the various food-stuffs, so that we may be in a position to draw up an adequate diet sheet.

The organic food-stuffs may conveniently be divided into two classes, the animal and the vegetable.

The Animal Food-Stuffs.—One of the most important of these, *viz.* *milk*, has been discussed in a separate chapter. Meat and eggs form another important class of animal foods. (See Table, p. 366.)

Eggs.—A hen's egg weighs about two ounces or fifty grammes. The *shell* forms about 12% of the total weight, and consists mainly of

carbonate of lime. The *white* consists of a multitude of very fine fibrous envelopes filled with a solution of protein (chiefly egg-albumin, but also traces of egg-globulin and egg-mucoid), containing traces of sugar (0.5 %), fatty substances, and inorganic salts. About 85 % of the white is water. We have already studied this. (See Proteins.) The *yolk* contains about 51 % of water, the solids being mainly fats (31.75 %), the chief of which is the phosphorised fat lecithin. It also contains about 16 % of protein, and this is mainly of the nature of a phospho-protein called vitellin. The proteins and fats are intimately united with one another in the yolk, the exact nature of the resulting compounds not being clearly understood.

The yolk contains about 1 % of inorganic salts, and it is important to note that the *phosphorus exists mainly in organic combination* (partly as lecithin and partly as phospho-protein). The same is true of the iron, which also exists in organic combination. Both these inorganic bodies are much more easily assimilated when presented to the tissues in organic combination.

Meat.—As meat consists mainly of the muscle of certain animals, we have already studied its composition in the previous chapter. It contains beside muscle a small amount of connective tissue and of fat. (See Table, p. 366.) Much of this fat is not visible to the naked eye, being situated between the muscle fibres. The amount of this fat varies in different animals, and in the same animals constitutes one of the chief differences between “prime” and “inferior” meat. Owing to the large amount of assimilable protein, meat forms one of our chief sources of nitrogen.

EXPERIMENT I. Cut very finely the piece of meat provided; grind with saline. Filter, and test the filtrate for proteins and salts.

The Vegetable Food-Stuffs.—The most important groups of these are the *pulses* and the *cereals*.

Pulses.—The pulses include such bodies as peas, lentils, beans. They contain relatively little water, and are rich in proteins, carbohydrates, and salts. (See Table, p. 366.) They are therefore a very valuable form of food-stuff, more particularly so owing to their cheapness; although it must be remembered that they are not so easily digested as meat, and more is found undigested in the faeces.

EXPERIMENT II. Extract some of the pea-meal provided with saline. Note the precipitate of globulin on adding a drop to water. Perform the general protein tests. Also extract some with cold water. On heating, a coagulum is obtained showing albumin. Filter. Test filtrate for salts.

Cereals.—These are obtained from the seeds of various artificially

cultivated grasses, and they all contain representatives of the various nutritive constituents of foods. The following table gives their general average composition :—

Water,	10-12 per cent.
Protein,	10-12 per cent.
Carbohydrate,	65-75 per cent.
Fat, -	0-5-8 per cent.
Mineral matter, -	about 2 per cent.

The more important varieties have the following composition : ¹

	Water.	Protein.	Fat.	Carbo- hydrate.	Cellulose.	Ash.
Wheat, -	12·0	12·11	1·7	71·2	2·2	1·9
Oats,	10	10·9	4·5	59·1	12·0	3·5
Barley,	12·3	10·1	1·9	69·5	3·8	2·4
Rice,	12	7·2	2	76·8	1·0	1·0

The most important of the cereal foods is wheat, of which it is estimated that 6 bushels per head of population are consumed every year. It is in the form of flour and bread that wheat is mainly consumed.

FLOUR.

Ordinary white flour is obtained from the endosperm of wheat grains and contains from 70 to 75 % of starch, about 8 % of protein, and about 1 % of fat. The protein is mainly of the nature of a globulin, and it has the property of becoming viscid when mixed with water. This viscid body is called *gluten*, and it is in virtue of this body that dough is formed when water is added to flour, as in the manufacture of bread.

EXPERIMENT III. Roll up some flour loosely in a piece of muslin ; place the bag thus formed in a small beaker containing some water and knead it. The starch grains pass through the muslin into the water, so that this soon becomes opaque and a sample placed in a test tube gives a blue colour with iodine. Apply Trommer's test to another sample and note that no sugar is present. After kneading for some time remove the bag and examine the contents, when it will be found that a sticky mass has been produced—gluten. Remove a piece of this and suspend it in water in a test tube. Apply Millon's and the xanthoproteic tests to it, and note that the suspended pieces of gluten react positively to both tests.

¹Taken from Hutchison's *Food and the Principles of Dietetics*.

The gluten is formed from two proteins in the flour, gliadin (a protein soluble in 70 to 80 % alcohol) and glutenin (soluble in alkali). It is to the gliadin portion that gluten owes its viscosity; grains poor in gliadin do not form dough when mixed with water, *e.g.* rice, oats, etc.

Good flour does not contain sugar, and if that be present it shows that a certain amount of germination has occurred.

Whole flour is obtained by crushing the entire grain minus the husk and outer portion of the bran. It contains somewhat more protein and fat than does white flour and is accordingly more nutritious, but on account of the admixture of bran which it contains, it is less digestible and acts as a mild laxative on the intestine.

BREAD AND BREAD MAKING.

The gluten which is formed when water is added to flour cannot be directly used as a food, for, on account of its soddenness, it is impervious to the digestive juices, and cannot therefore be digested. Before it can be digested it must be aerated, *i.e.* rendered porous, and in this state it forms *bread*. The agency employed to aerate the bread is carbon dioxide gas, which is generated in the mass of gluten or "dough" by the action of the yeast plant on sugar.

The following is a brief account of the process of bread making:—The first stage in the process consists in preparing an active culture of the yeast plant. This was originally done by allowing dough to stand exposed to the air, when some of the yeast cells, which appear to be omnipresent in the atmosphere, settled on it, and grew and multiplied there until a fermenting mass or "*leaven*" was obtained. Unfortunately for this process, however, the atmosphere contains other bacteria which also settle on the dough, and by their growth lead to the production of organic acids, in consequence of which the mass became very sour. To make bread a little of the leaven was added to fresh dough, in which it grew and multiplied until the whole was leavened, the aerated mass being then heated so as to stop the fermentation. Such bread is very sour, and although the process is still carried out in some parts of Germany, it is almost obsolete.

In the modern process the leaven gives way to the so-called *ferment*, which is produced by adding some pure yeast obtained from the brewery to a culture medium consisting of a mixture of mashed potatoes and flour, the culture being kept in a warm place for about five hours. By this time the mass is swarming with young actively-growing yeast cells, and, provided that contamination with bacteria has been prevented, none of the sour acids which develop in leaven are present. Besides the yeast, an unorganised ferment called *diastase*, originally present in the flour, becomes active and hydrolyses some of the starch of the flour into sugar. The yeast cells then act on this to produce alcohol and carbonic acid gas, so that a fermenting mass is obtained. More flour is now added to this, and the process allowed to proceed five or six hours longer, until the developed gas causes the top to burst, after which the remainder of the flour is added. The mass is now called dough. It is thoroughly mixed by machinery, and allowed to

ferment for another hour, when it is weighed out into loaves, which are then placed in pans and heated to about 232° C. in an oven for an hour and a half. The heat kills the yeast, but at the same time causes the enclosed bubbles of gas to expand, so that the dough becomes filled with little cavities. The heat also causes the outer part of the dough to become hardened by coagulating the protein, and at the same time it converts the starch into dextrin and soluble starch, and so forms the crust. The crust is glazed because of the dextrin, and it is coloured and its taste different from the rest of the bread, because of the caramel produced by the action of the heat on the sugar which is developed.

EXPERIMENT IV. Shake up some bread thoroughly with cold water and filter off the extract. Test the residue for starch by adding iodine, and for protein by the colour tests. Test the filtrate for sugar by Trommer's test. All the reactions are positive. If a similar extract be made of the crust it will be found to give a purplish colour with iodine, due to the soluble starch and dextrin which it contains.

The colour tests for protein and starch can also be well demonstrated by pouring the necessary reagents upon different areas of a piece of bread. Do this, taking care to use a minimum amount of the reagents. To bring out the red colour of Millon's test, it is necessary to toast the bread slightly over the Bunsen flame.

PERCENTAGE AVERAGE COMPOSITION OF SOME OF THE MORE IMPORTANT FOOD-STUFFS.

(Adapted from various sources.)

	Water.	Proteins.	Fats.	Carbo- hydrates.	Salts.
Beef (best quality),	72	21	6	—	1
Biscuits,	8	15	1·3	73·4	1·7
Bread (wheaten),	40	8	1·5	49·2	1·3
Butter (fresh),	12	2	85	—	1
Cheese,	41	28	23	1	7
Eggs,	73·5	13·5	11·6	—	1·4
Fish (salmon),	76	15	7	—	2
Fish (sole), -	86	12	0·5	—	1·5
Flour (fine wheaten), -	16·5	13	1·5	68·3	0·7
Lentils,	12·5	24·8	1·8	58·4	2·5
Milk (cow's), -	86·9	4·7	3·5	4·2	0·7
Mutton,	76	18	5	—	1
Oatmeal, -	15	13	6	63	3
Peas, -	15·6	22	2	58	2·4
Potatoes, -	74	2	0·2	21·8	1
Rice, - - -	10	5	0·1	84·4	0·5

In the above table note particularly the great food value of such bodies as bread, flour, cheese (particularly), lentils, peas, oatmeal, rice; all comparatively cheap articles of diet.

The Methods for the Estimation of General Metabolism.—Metabolism is the subject which treats of the changes undergone by the food-stuffs after they are absorbed from the intestine. There are two subdivisions of the subject; the one, called *general metabolism*, has to do with the building up or breaking down of the tissues. It derives its information from a comparison of the amount of the various food-stuffs absorbed, with the amount of their excretory products. The other, called *special metabolism*, has to do with the exact chemical changes which absorbed food-stuffs undergo, and the localisation of the actual organ or organs in which the various changes are effected.

Space will only permit us to indicate some of the methods employed in studying general metabolism, and to describe briefly how the results obtained may be interpreted. The actual methods of analysis are fully described in other chapters, and in the following description reference will be made to the pages on which the most suitable method for each determination can be found.

General Metabolism.—In order to study this a balance sheet must be drawn up, on one side of which is placed the *intake* (the amount of food and oxygen absorbed), and on the other the *output* (the amount of the various bodies excreted in the urine, faeces, breath, and sweat).

I. The Intake.—The value of a diet can be expressed either as its chemical value, or as its physical value. The *chemical value* means the amount of protein, fat, carbohydrate, and salt which it contains. This is determined by referring to analytical tables of the various food-stuffs (especially serviceable for this purpose are the tables of Atwater). The amount of the various food-stuffs administered can then be easily determined by multiplying the percentage given on the tables by the amount of food given. When it is desired to be specially accurate an actual analysis of the food is necessary, and when the metabolism of protein is being specially studied, it is customary to determine the amount of nitrogen which the food-stuff contains (Kjeldahl's method, p. 410), and this multiplied by 6.3 gives the amount of protein.¹

The *physiological heat value* of a diet means the number of calories which it can yield during its metabolism in the body. To find the total heat value of the diet, all that is necessary is to multiply the physiological heat values of the administered food-stuffs by the amount of each which the diet contains.

The Form in which the Food-Stuffs are best given for Metabolism Experiments. Protein.—This is usually given as meat, from which all the visible fat and tendon are, as far as possible, removed. When calculating the amount of protein from the nitrogen present, the gelatin and extractives which the meat contains may be neglected, for gelatin, in the presence of an excess of protein, has almost the same metabolic value as native proteins, and the extractives exert no influence on the metabolism since they pass through the tissues unchanged. Protein may also be administered as white of egg or as milk.

Carbohydrate.—This is best given as bread a day old, and always obtained from the same source, so that its composition is constant.

¹This figure would not be correct if the food contained nitrogenous substances other than protein.

Fat.—About 1% fat has to be reckoned as contained in the meat prepared as above. The rest is given best as butter.

When the investigation is being carried out on an animal, the whole diet should be weighed out in the morning, after collecting the previous day's excreta. It is seldom necessary to cook the food, but where there is difficulty in persuading the animal to take some unpalatable food substance, this latter may be mixed with the soup prepared from the meat. When the experiments are being carried out on man, it is of course necessary to cook the meat, and frequently also some of the other food-stuffs. The various constituents must be weighed out before cooking, as it is impossible to know, after the food has been prepared, the proportion of the substance used in cooking. For observations extending over any length of time the diet should be carefully chosen, and exactly the same amounts given each day.

II. The Output.—By referring to the above scheme it will be seen that the only food-stuff which contains nitrogen and sulphur is protein. We have, therefore, two excretory products from the amount of which we can determine protein metabolism. In the case of carbohydrates and fats, on the other hand, there is no exclusive end product, so that, in order to estimate the metabolism of these two bodies, it is necessary to make a calculation.

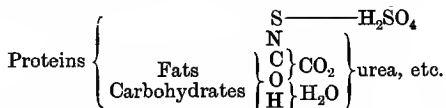

1. **Protein.**—The output of this is determined :

(a) **From the Amount of Nitrogen Excreted.**—Nearly the whole of this occurs in the urine in which it is determined by Kjeldahl's method (p. 410). A certain amount, however, appears in the faeces. With an ordinary diet most of this latter comes from the unabsorbed protein, and must accordingly be deducted from the amount administered in order to ascertain the actual amount absorbed. A certain amount of it, however, comes from nitrogenous bodies, which are excreted into the intestine from the blood. The actual amount of this excretory nitrogen has been determined by feeding an animal with a protein free diet, and for man it amounts on an average to 1 grm. per diem. During starvation it only amounts to 0·2 grm., so that it is obvious that it comes from the digestive juices and excreta poured into the intestine.¹

The amount of nitrogen excreted in the sweat is so small as to be negligible. The urinary nitrogen, plus one gramme per diem, as nitrogen excreted into the intestine, gives us, therefore, the total amount of nitrogen excreted. Since protein contains 16% of nitrogen, each gramme of nitrogen corresponds to 6·25 grm. of protein, and since meat contains on an average 3·4% of nitrogen, each gramme of the latter will correspond to 30 grm. of muscle.

(b) **From the amount of Sulphur Extracted.**—The proteins of food contain 1% of sulphur. This is excreted in the urine largely as sulphuric acid, and the

¹In accurate metabolism determinations it is necessary to collect the faeces for each day, to dry them slowly on a sand bath, and then to make the following determinations :

- (a) The total amount of nitrogen.
- (b) The total amount of fat (*i.e.* extract with Soxhlet's apparatus).
- (c) The total amount of solids.

amount of this excreted bears a constant relationship to that of nitrogen, viz. 1 of sulphuric acid for every 5.2 gr. of nitrogen. Being less in amount, its determination is not so accurate as that of nitrogen, but it affords us a valuable *control* in estimating protein metabolism, and is the only way by which we can estimate this when nitrogenous bodies other than protein are contained in the diet.

2. Fat and Carbohydrate.—The end products of the metabolism of both these bodies are water and carbon dioxide gas, and, of these two bodies, the only one which it is possible to estimate with ease is the latter. Protein, however, also contributes to the excretion of carbon dioxide, so that, before we can know how much carbohydrate and fat are being oxidised in the body, we must find out what proportion of the total carbon excreted is derived from the metabolism of the protein.

To estimate the total amount of carbon excreted, the expired air must be collected, and a determination of the amount of carbon dioxide which it contains made by one of the methods described (see p. 184). The obtained result multiplied by 0.273 gives the amount of *carbon excreted in the breath*. A certain amount of *carbon is also excreted in the urine*. This latter amount could be directly determined by making an elementary analysis of the dried urine, but such a method would, of course, be too laborious for metabolism work. In order to determine this amount of carbon it is sufficiently accurate to multiply the nitrogen excreted by 0.67, for it has been determined that, for every gramme of nitrogen excreted, there is this amount of carbon, and that this ratio is a constant one.

Having estimated what the total excretion of carbon is, we must now ascertain how much of it comes from protein. To do this multiply the total amount of nitrogen excreted by 3.3 (since proteins contain approximately 52.8 of carbon, and 16 of nitrogen). If this amount of carbon be deducted from the total amount excreted, the remainder corresponds to the carbon derived from the combustion of fat and carbohydrate. As to which of these two bodies it is from which the carbon really comes, we have no means of telling definitely, except by a determination of the respiratory quotient, but since there is very much more fat than carbohydrate in the tissues we usually reckon it as fat. Each gramme of carbon corresponds to 1.3 grammes of fat (because fat contains 76.5 grammes carbon).

3. The Amount of Energy given out by the Body.—The energy is liberated in the body partly as heat, and partly as muscular work. The amount actually lost as heat may be determined by placing the animal in a respiration calorimeter, but it is difficult to estimate the amount lost as mechanical work.

There are, however, certain *indirect methods* by which the total amount of energy liberated may be determined, and these are as follows: (a) By comparing the amount of food-stuffs taken in with the amount which reappears in the excreta, we can find out how much of each food-stuff has actually undergone metabolism in the tissues. It is now quite easy to find how much energy this corresponds to, by *multiplying the amount of each food-stuff metabolised by its caloric value*. (Where the diet contains both fat and carbohydrate, and where an accurate balance of intake and output of carbon does not exist, we must reckon the excess or deficit as fat, since there is much evidence to show that the amount of carbohydrate in the body remains pretty constant.)

(b) The extent of oxidation in the tissues is determined, not by the amount of oxygen inspired, but by the activity of the tissues. We can, therefore, employ

the amount of oxygen absorbed by the tissues as an index of the amount of energy liberated in them. In order to do this, however, it is necessary to remember that the amount of energy liberated, when different food-stuffs are burnt, is not the same; thus 100 gr. of oxygen are necessary for the combustion of 35 gr. of fat, the amount of energy hereby liberated amounting to 325 calories. The same amount of oxygen will burn up 84.4 grm. of carbohydrate, and yield thereby 346 calories, or 74.4 grm. protein yielding 362 calories. It is therefore necessary, before employing the oxygen absorbed as an index of the amount of energy liberated, to ascertain that, when the determination is being made, the food-stuffs undergoing oxidation are always the same. This can be ascertained by estimating the respiratory quotient, the value of this being influenced mainly by the nature of the food-stuff undergoing combustion at the time (see p. 185). So long as the *R.Q.* remains constant, any increase or diminution in the amount of oxygen absorbed represents more or less energy liberated. In order that we may be able to compare the oxygen assimilation of different individuals under the same conditions, Zuntz has suggested that the determination should be made the first thing in the morning, immediately on awakening, and twelve hours after the last diet (which should not contain much carbohydrate) has been taken. The estimation should be made by Zuntz respiratory apparatus. The amount of oxygen absorbed, and of carbon dioxide exhaled, is then reckoned for each kilo. body weight, and for each minute. The normal amounts for man are 3 to 4.5 c.c. oxygen, and 2.5 to 3.5 c.c. carbon dioxide.

Example of a Metabolism Investigation.—It is desired to know whether a diet containing 125 grammes protein, 50 grammes fat, and 500 grammes carbohydrate is sufficient for a man doing a moderate amount of work.

	INTAKE.		
	Carbon.	Nitrogen.	Calories.
Protein,	62 grm.	20 grm.	512.5
Carbohydrate, -	200	—	2050.0
Fat, -	38	—	465.0
	<hr style="width: 50%; margin: 0 auto;"/>	<hr style="width: 50%; margin: 0 auto;"/>	<hr style="width: 50%; margin: 0 auto;"/>
Total,	300 grm.	20 grm.	3027.5

	OUTPUT.	
	Carbon.	Nitrogen.
In urine,	- 11 grm.	(16.5 × 0.67)
In faeces, -	5	1.0
In the breath,	254	—
	<hr style="width: 50%; margin: 0 auto;"/>	<hr style="width: 50%; margin: 0 auto;"/>
Total,	270 grm.	17.5 grm.

Retained in body = 30 grammes carbon and 2.5 grammes nitrogen. This amount of nitrogen represents $2.5 \times 6.25 = 15.6$ grammes *protein*, or 75 grammes *muscle*. Now, this amount of protein will account for 8.25 grammes carbon; so that $30 - 8.25 = 21.75$ grammes carbon represent $21.75 \times 1.3 = 28.3$ grammes *fat*. On this diet, therefore, the subject retains in his tissues 15.6 gr. protein and 28.3 gr. fat per diem.

To express this result in terms of energy liberated, we know that 3027.5 C. were supplied and that all these have been used except $15.6 \times 4.1 = 64$ retained as protein, and $28.3 \times 9.3 = 263.2$ retained as fat, or *in toto* 327.2 C. We find, therefore, that $3027.5 - 327.2 = 2,700$ C. have been required.

CHAPTER XII.

DIGESTION IN THE MOUTH.

THE salivary glands—parotid, sublingual, and submaxillary—along with the numerous isolated gland acini scattered in the buccal mucosa, pour into the mouth a secretion known as saliva. The composition of this mixed saliva is as follows :

Water,	99.42 %
Organic matter,	0.36 ,,
Mucus and epithelial cells. Ptyalin and soluble protein.	
Potassium sulphocyanide (KCNS).	
Inorganic matter,	0.22 ,,
Chlorides, phosphates, and carbonates of alkalies and alkaline earths.	

It is, therefore, a very dilute secretion (specific gravity about 1005).

The total secretion during twenty-four hours amounts to about the same as that of the urine, *i.e.* 1500 c.c.

The saliva secreted by the different glands varies somewhat in composition ; that from the parotid contains no mucus, and is consequently a thinner fluid than that of the submaxillary, which contains much mucus. The sublingual saliva also contains a certain amount of mucus.

Collect some saliva in a test tube,¹ and perform the following reactions with it :

I. To identify the various Constituents.

EXPERIMENT I. Place a drop of saliva on red litmus paper ; a blue stain results. The reaction may, however, become acid where decomposition is taking place in the mouth, as is the case in decaying teeth.

EXPERIMENT II. Place a drop of saliva on a slide, cover and examine under the microscope : two kinds of cells will be seen, *viz.* (1) large, flat, squamous cells, which have been desquamated from the surface of the stratified epithelium of the mouth ; (2) small round cells like leucocytes, which come either from the glands themselves or from the tonsils.

EXPERIMENT III. Place some saliva in a test tube and dilute it with an equal quantity of water ; now add a few drops of 10 per cent. acetic acid, when a stringy precipitate of mucus will form. Filter off this precipitate, and note that the filtrate is watery, showing that the stringy character of saliva is due to the mucus which it contains. To the

¹The secretion of saliva may be stimulated by inhaling acetic acid through the mouth, or by chewing rubber.

filtrate add a few drops of Millon's reagent and boil. The result shows the presence of protein.

EXPERIMENT IV. Add to some saliva in a test tube a drop of a weak solution of ferric chloride (Liq. Ferri. Perchlor. B.P.) and a drop of hydrochloric acid. A red colour is sometimes produced. This is due to the production of ferric sulphocyanide by interaction between the ferric chloride and a sulphocyanide which is contained in saliva. The red colour is discharged by adding a few drops of a solution of mercuric chloride (1-1000). A more sensitive way of performing this test is to place a drop of saliva at one end of a piece of filter paper, and then to allow a drop of ferric chloride solution (acidified with HCl), spread to the edge of the saliva drop; a deep red stain will result where the two moistened areas meet.

EXPERIMENT V. If some saliva be allowed to stand for an hour or so, it becomes milky or a thin surface film forms on it. This is due to the precipitation of calcium carbonate, which exists in fresh saliva in a soluble state as calcium bicarbonate. On standing exposed to the air, however, carbonic acid gas is given off, in consequence of which the bicarbonate changes into carbonate, which is insoluble. A similar precipitation of calcium carbonate, carrying with it a certain amount of calcium phosphate, sometimes occurs in the ducts of the glands and leads to the formation of calculi, or it may form on the teeth, where it leads to the formation of *tartar*.

II. To Study the Action of the Ferment Ptyalin.

EXPERIMENT VI. Place a few cubic centimetres of a 0.5 per cent. solution of starch in two test tubes, *a* and *b*. To *b* add about an equal amount of saliva, and place both *a* and *b* in the water-bath heated to body temperature. Note that in a very few minutes the solution in *b* loses its opalescence and becomes clear. By means of a glass rod transfer drops from each solution, about once a minute, to a white slab or dry evaporating dish, and add to each drop a little iodine solution. In the drops from the test tube *b* the blue colour becomes at first purplish and then reddish brown, and ultimately disappears. When this stage has been reached, apply Trommer's or Fehling's test to the contents of the test tube, and note that reduction occurs. In the case of *a* the blue colour persists throughout and reduction of cupric salts does not occur.

What has occurred in *b* is that the ptyalin has hydrolysed the polysaccharide starch (blue with iodine and no reducing power), first into a simpler polysaccharide dextrin (red with iodine, no reducing power), and then into the disaccharide maltose (no colour with iodine, reduces cupric salts). If left in contact with the maltose for some time the saliva can invert this, yielding dextrose. This indicates the presence

of maltase (see p. 403). There are several varieties of dextrin formed during the hydrolysis, one of these gives the iodine reaction described above, and is called erythro-dextrin; another, called achroo-dextrin, gives no reaction with iodine. The latter exists as an intermediate stage between erythro-dextrin and maltose.

The very first effect of ptyalin on starch is to convert it into so-called soluble starch (sometimes called amylo-dextrin). This gives a clear solution with water and a blue reaction with iodine. During each step in the hydrolytic break down, a certain amount of maltose is set free. This is small in amount at first, but becomes progressively more with each successive dextrin formed.

EXPERIMENT VII. Place some of 0.5 per cent. solution of starch in the mouth, and after about two minutes transfer it to a test tube. Ascertain if reduction of cupric salts occurs. Repeat this experiment with some unboiled starch, and note the difference in the two cases (see Carbohydrates, p. 290).

The ptyalin will only act in neutral or very faintly alkaline reaction, but not in the presence of free acid (*e.g.* 0.003 % HCl can practically stop its action). Stronger alkalinity destroys it.

EXPERIMENT VIII. If Experiment VI. be repeated with the addition of a few drops of 0.2 per cent. hydrochloric acid, so that the fluid just reacts acid to litmus, it will be noticed that no dextrin is produced. (If the acid mixture be heated for a considerable time a trace of reducing sugar may appear because of the hydrolysing action of the acid.)

From the result of Experiment VIII. we may conclude that it would be impossible for the action of the ptyalin to proceed in the stomach after the gastric contents had become distinctly acid. If the stomach be empty at the beginning of the meal, however, the action of ptyalin may proceed in this viscus for some considerable time, since the first portion of acid which is secreted becomes bound to protein, so that it does not exercise its inhibiting influence on the ptyalin which has been swallowed.

A certain amount of the hydrochloric acid secreted by the stomach will also combine with the alkalies of saliva to form chlorides. These chlorides have a marked accelerating influence on the action of saliva. Although, therefore, ptyalin has little chance in the mouth to carry its action on starch far, it can, nevertheless, continue acting for some considerable time in the fundus of the stomach. The extent of this action no doubt varies in different cases, being probably more prolonged when the food is taken without much liquid.

One of the chief functions of the saliva is undoubtedly a mechanical one, acting as a solvent for certain foods, and assisting in the mastication.

tion and swallowing of others. A body must be in solution before it can be tasted, so that the saliva assists in the appreciation of taste. It is also necessary for articulation and for preserving the sensitiveness of the nerve endings of taste and common sensation. This explains why a fever patient cannot taste things so well as during health. It is interesting to note that in some animals the saliva contains little or no amylolytic ferment (*e.g.* dog and cat).

For accurately studying the action of ptyalin (or any other amylolytic ferment) on starch one may estimate the reducing power (Bang's method, gravimetric method, polarimeter) of the incubated solution after a certain time. Besides being tedious, this method is uncertain, because of the different reducing powers of maltose and dextrose, both of which sugars frequently result by salivary digestion, especially when this is prolonged.

A simpler and more serviceable method depends on the colour reaction of starch with iodine, and is conducted as follows:—

Prepare a 1 per cent. starch paste solution,¹ and place the beaker containing it in ice water. Collect some saliva and dilute 1 c.c. of it to 10 c.c. with distilled water, and filter. Take a series of five test tubes labelled *A*, *B*, *C*, etc., and with a 1 c.c. pipette graduated in 100 parts deliver into tube *A* 1 c.c. of the diluted saliva; into *B* 0.75 c.c.; into *C* 0.5; into *D* 0.25; and into *E* 0.1.

Place the tubes in a beaker containing ice water, and then deliver into each 5 c.c. of 1 per cent. cooled starch solution. The cold prevents any ferment action until all are ready. Now remove the tubes to another beaker containing water at 40° C., and gently shake them so that the contents become thoroughly mixed. Note the exact time at which the tubes are placed in the warm water. At the end of half an hour remove the tubes simultaneously to ice water, and shake them gently so as to ensure thorough cooling. Fill each tube to within half an inch of the top with distilled water and add a few drops of iodine solution $\left(\frac{N}{10}\right)$.² Close each tube with the finger and invert so as to mix. It will be seen that there is a gradation of colours in the different tubes from blue through violet and brown to yellow. Note the tube which just shows a bluish tint. The next one higher up in the series is taken as that in which all starch has just disappeared. From the amount of diluted solution added to this, calculate the amount of undiluted saliva required to convert 100 c.c. of 1 per cent. starch solution into dextrines in half an hour at 40° C. Thus, suppose that the tube containing 0.25 c.c. diluted saliva is found to be that which just shows a bluish tint. In the next (*viz.* containing 0.5 c.c. saliva) all the starch has disappeared, therefore $\frac{0.5}{10} = .05$ c.c. saliva can hydrolyse 5 c.c. 1 per cent. starch, or 1 c.c. can invert 100 c.c. 1 per cent. starch. The diastatic action

¹Weigh 1 or 2 gm. of pulverized "soluble starch," and stir it up in a beaker with an amount of distilled water sufficient to make a 1 per cent. solution. Place on a boiling water bath and continue stirring until a clear opalescent solution is obtained. Cool before using.

²Care must be taken that sufficient iodine solution is added to give the maximal reaction, but an excess must be avoided. The iodine solution is made by dissolving 12.7 gr. iodine in water containing 25 gr. potassium iodide, and then diluting to 1000 c.c.

of pancreatic juice, of liver extract, of blood serum or of malt diastase may be measured in the same way, but different amounts of the ferment solution must be employed.¹ (Thus for blood serum and liver extract it is unnecessary to dilute the solution.) The results may be expressed by the formula² $D \frac{40^\circ}{30'}$, in which the temperature and the length of time of incubation are shown. In the above example $D \frac{40^\circ}{30'} = 1$.

To study the influence of weak acids, etc., on the action of ptyalin the above method is very satisfactory, *i.e.* by adding some acid solution to one or more of the tubes. In some cases it is desirable to prolong the incubation for twenty-four hours, in which case some chloroform or toluol or thymol should be added to retard the development of micro-organisms. If very close results are desired, the observation should be performed with amounts of ferment solution which vary from one another by smaller amounts, or a second observation should be made taking amounts of ferment solution lying between the faintest blue and the next tube.

It is of interest to compare by the above method the comparative diastatic powers of the various commercial preparations of diastase, taking human saliva as the standard.

CHAPTER XIII.

DIGESTION IN THE STOMACH.

THE food, after being masticated in the mouth, is passed down the oesophagus into the stomach, where it is acted on by the gastric juice, and is gradually forced out through the pylorus. Normally the stomach is again empty in about five hours after a meal. The food collects at first in the fundus of the stomach, which becomes dilated to receive it. By gradually contracting the fundus forces the food in small quantities at a time into the pyloric region, in which there are frequent peristaltic movements which cause the food to be moved about, and thus more intimately mixed with the digestive juices. When properly disseminated and distinctly acid in reaction this food causes the pyloric sphincter to relax, so that it is passed into the duodenum; but only small quantities at a time are allowed to pass, the sphincter closing between each portion. While lying in the fundus, very considerable digestion of starch by swallowed ptyalin is taking place. On entering the stomach the food is very little changed, except

¹ Care must be taken when using organ extracts, such as those of liver, that the reaction of the incubation mixture is kept constant. This is best accomplished by adding a few drops of a saturated solution of Na_2HPO_4 to the solutions.

² D = diastatic power.

that it has been masticated. On leaving it, however, its appearance is quite altered, being now a thick, more or less coloured, fluid called chyme.

Various methods have been adopted for studying gastric digestion—*e.g.* observing the process through a gastric fistula, and removing samples of the gastric contents by means of a stomach tube. In order to obtain pure gastric juice the most reliable method is that introduced by Pawlow, which consists in resecting a portion of the fundus of the stomach, and sewing it up so as to form a bag, which is then sutured to an abdominal fistula. This isolated sac of stomach secretes pure gastric juice, which may be collected from the fistula. The juice secreted by this miniature stomach has been shown to be identical in amount and strength with that secreted in the main stomach.

The Composition of Gastric Juice.—Pure gastric juice obtained by Pawlow's method is a clear, colourless fluid, with a specific gravity of 1003-1006, and of acid reaction.

Its percentage composition varies in different animals, that of the dog and of man being as follows :

	Man.	Dog.
Water, -	99·44	97·3
Organic matter, chiefly pepsin,	0·32	1·71
Inorganic matter—		
(a) free hydrochloric acid,	0·2-0·3	0·3 ¹
(b) salts,	0·1-0·2	0·66

The most important features to be considered in connection with this table are : (1) the presence of free hydrochloric acid, and (2) the nature of the organic matter.

THE ACIDITY OF THE GASTRIC JUICE.

In marked contrast to most of the other fluids of the animal body, the gastric juice has a strong acid reaction towards all indicators. This acidity performs a very important rôle in the process of digestion in the stomach, which makes it of interest and importance to study carefully. The urine also reacts acid towards certain indicators, but the acidity in this case can readily be shown to be due to quite another cause from that of the acidity of the gastric juice. In certain diseased conditions, alterations take place in the degree and nature of the acidity of gastric juice, and these alterations are sometimes of value in assisting in the diagnosis of the pathological condition.

From a chemical standpoint acidity is invariably due to the presence of excess of hydrogen ions in the solution. For the presence of these

¹ Pawlow always found more than 0·3 per cent.—namely, 0·5-0·6 per cent.

hydrogen ions, one or other of three general causes may be responsible, viz. the presence of free mineral acid, free organic acid, and acid salt. The acidity in each case is in direct proportion to the dissociation of the acid in watery solution, being greatest for mineral acid. One of the first questions, therefore, which confronts us in connection with the acidity of gastric juice is: to which of the above causes is the presence of hydrogen ions due? The question is most simply answered by the use of indicators, for it has been found that the behaviour of these varies with the nature and cause of the acidity.

Let us see, first of all, whether the acidity is due to a *free acid* or to an *acid salt*. Congo red is the most useful indicator for this purpose.

EXPERIMENT I. To a 0.2 per cent. HCl solution add a few drops of congo red solution:¹ the red turns to blue. Repeat with a dilute solution of acid sodium (NaH_2PO_4) phosphate—no blue colour develops. Show that the latter solution reacts acid towards litmus or phenolphthalein. Repeat this experiment, using, instead of a congo red solution, pieces of congo red paper prepared by dipping filter paper in a congo red solution and drying.

The result with congo red indicates that the acidity is due to free acid, but it does not tell us whether this is a mineral or an organic acid, for both of these turn it blue, although the mineral acid does so much more readily, *i.e.* in much greater dilution than the organic. (Indeed, if a solution of the acidity of gastric juice—as determined by the method described on p. 381—gives the reaction with congo red distinctly, especially when congo red papers are used, it is almost certain evidence that free mineral acid, and not organic acid, is the cause of the acidity.)

To further trace the cause of the acidity, use is made of several indicators whose behaviour towards dilute organic and combined mineral acids is quite different from that occurring in the presence of free mineral acid. The most important of these indicators are employed in the following experiments which should be performed with 0.2 per cent. hydrochloric acid solution, $\frac{N}{100}$ hydrochloric acid solution (0.0365 per cent.), $\frac{N}{10}$ lactic acid solution (0.9 per cent.) and $\frac{N}{100}$ lactic acid solution (0.09 per cent.).

EXPERIMENT II. Günzberg's Test. Place a few drops of the reagent (a solution of 2 parts phloroglucin and 1 part vanillin in 30 parts 95 per cent. alcohol) in an evaporating basin, and add a few drops of

¹ *Congo red solution*—dissolve 0.5 gm. of congo red in 100 c.c. of 10 per cent. alcohol.

the liquid to be tested. Slowly evaporate to dryness. With dilute hydrochloric acid a red colour develops, with lactic acid no red colour.

EXPERIMENT III. The Tropaeolin Test. Place a drop of a saturated solution of Tropaeolin-00¹ in 95 per cent. alcohol in a dry evaporating dish, and dry it with moderate heat. To the yellow stain which results apply a drop of 0.2 per cent. hydrochloric acid. A purple colour is produced. Repeat with the other acid solutions provided.

EXPERIMENT IV. Di-methyl-amino-azo-benzol

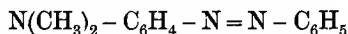

(Töpfer's Test).² Add 1-2 drops of the reagent to some of the solution to be tested. If this contain free mineral acid a pinkish red colour develops. Organic acids, even when quite dilute, will also give a faint red colour with this reagent.

It will be found, as a result of these experiments, that the reactions obtained with the hydrochloric acid solutions are more or less simulated by those of the stronger lactic acid solution, except in the case of Günzberg's reaction. On the other hand, this reagent gives a positive result with hydrochloric acid diluted to 1 in 10,000 parts. The tropaeolin and the azo-benzol reactions with 0.2 HCl are also quite distinguishable from those given by lactic acid solutions of the above strengths, but in greater dilutions of HCl the distinction is by no means so definite.

If the contents of the stomach (removed by a stomach tube or through a fistula) be tested with any of the above reagents some three hours after an ordinary meal, results like those obtained with the HCl solutions will be observed. This is taken as evidence of the presence of free hydrochloric acid. Absolute proof that it is this, and not some other mineral acid, that is the cause of the positive result has been furnished by comparing the total amount of bases with the total amount of acids in the ash of gastric juice (see p. 381): it has been found that there is an excess of chlorine over that required to combine with the bases to form chlorides. This chlorine must exist in the juice as hydrochloric acid.

The Functions of the Acid.—These are generally stated as being two in number.

1. To assist in the action of the proteolytic ferment, pepsin. Evidence of this will be furnished when we study the action of pepsin. For the present it is important to note that the acid combines with the protein, and that the amount of acid which thus combines increases

¹ 00 represents a trade brand.

² Dissolve 0.5 gr. di-methyl-amino-azo-benzol in 100 c.c. 95 per cent. alcohol.

as digestion proceeds, because the combining power of the proteoses and peptones for hydrochloric acid is greater than that of native protein. In consequence of this increasing absorption of hydrochloric acid during peptic digestion, the acid becomes combined as soon as it is secreted for some considerable time after the start of digestion. After a test meal of soup, meat (200 gr.) and bread (50 gr.) it takes from three to four hours before there comes to be any *free* hydrochloric acid detectable in the gastric contents, although during all this time the acid is being actively secreted. In cancer and in catarrhal conditions of the gastric mucosa, and in fever, the secretion of hydrochloric acid is depressed so that it may all become combined with protein and never appear in the free state, *i.e.* never come to react with the above indicators.

2. To prevent putrefaction in the stomach. Hydrochloric acid in the free state, like any other mineral acid, is a strong antiseptic. The micro-organisms with which our food is contaminated are therefore destroyed before they have had time to multiply to any degree in the stomach. If it were not for this, the stomach contents would serve as a most favourable place for the growth of these micro-organisms, and putrefaction and fermentation would become excessive in them. This is actually what occurs when the secretion of hydrochloric acid is deficient, as in cancer. If, in such cases, the reaction of the stomach contents be tested, it will nevertheless be found strongly acid to litmus, and if, furthermore, the degree of this acidity be estimated (by the method described on page 381), it may be found even higher than that of normal gastric contents. By the application of the indicator tests described above (especially Günzberg's), it can readily be shown that the acidity is not due to free hydrochloric acid. This leaves, as its possible causes, hydrochloric acid combined with protein, acid salts, and organic acids. Since it is known that micro-organismal growth is apt to produce organic acids, especially lactic acid, we next proceed to test for the presence of this.

EXPERIMENT V. The test for lactic acid is performed with an ethereal extract of the gastric contents, which is made by mixing 5 c.c. of the gastric contents with 30 c.c. ether in a separating funnel, then gently shaking the two with a rotatory motion (avoid violent shaking, else an emulsion is apt to occur), and, after settling, pouring off the ether. The ethereal extract is then evaporated to dryness,¹ the residue dissolved in a little water, and the resulting solution tested with Uffel-

¹In evaporating ether, *be very careful that no flame is near.* The evaporation should be performed on a water bath that has been heated, and the flame then extinguished.

mann's reagent (30 c.c. 1 % phenol solution and a few drops of ferric chloride solution). The blue violet colour of the reagent changes to a characteristic yellow when lactic acid is present.¹

A much more sensitive and characteristic test for lactic acid is *Hopkins'*, which is applied as follows :

EXPERIMENT VI. Mix some of the dry ethereal extract of stomach contents with 5 c.c. concentrated sulphuric acid, and transfer to a dry test tube. Add 3 drops of a saturated solution of copper sulphate, mix, heat the mixture in a boiling water bath for 2 minutes. Cool under the tap, and add 2 drops of a 0.2 per cent. alcoholic solution of thiophene and shake. Replace the tube in the boiling water bath, and examine it frequently, when a cherry red colour will be found to develop if lactic acid is present. Prolonged heating causes the solution to become very dark.

The lactic acid is produced by the action of the *bacillus acidi lactici* and other organisms on sugars (see Milk, p. 329). .

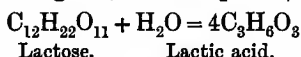

The fermentative process seldom stops at the production of lactic acid. Other bacteria act on the lactic acid and produce butyric acid, carbon dioxide gas, and hydrogen.

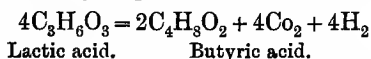

These gases accumulate in the stomach, causing flatulence. The presence of butyric acid usually reveals itself by the odour of the gastric contents. When its presence is doubtful, boil a portion of the fluid and hold a strip of blue litmus paper in the steam. If this turns red, it indicates a volatile acid (butyric or acetic). Butyric acid has a characteristic odour.

Acid phosphates (NaH_2PO_4) when present in gastric contents are demonstrated by mixing calcium carbonate with a portion of the fluid. If an acid reaction still remains towards litmus paper, acid phosphates must be present, since the calcium carbonate will have combined with the free acids.

In the *clinical examination of the stomach contents* numerous methods have been introduced for the purpose of estimating the *total acidity*, the *total amount of hydrochloric acid*, and the *amount of free (uncombined) hydrochloric acid* contained therein. It would be out of place to go exhaustively into these methods here, but a brief outline of the most trustworthy may be of value.

¹ It is indispensable to make an ethereal extract for this test, because alcohol, sugar and phosphates give the reaction, and one or other of these is always present in the gastric contents.

1. **Total Acidity.**—A measured quantity (10 c.c.) of filtered gastric contents is mixed in an Erlenmeyer flask with ten times its bulk of distilled water. Two or three drops of a solution of phenol-phthalein are added, and the solution is titrated with $\frac{N}{10}$ caustic soda solution until a faint pink colour is just obtained. The number of c.c. of alkali required is read off, and the result expressed as the amount of $\frac{N}{10}$ alkali required to neutralise the acids in 100 c.c. filtered gastric contents. Thus, an acidity of 40 would mean that 40 c.c. of $\frac{N}{10}$ alkali had been required to neutralise the acids of 100 c.c. gastric contents. The result may also be expressed in terms of HCl, and this is the method most useful in physiology. 1 c.c. $\frac{N}{10}$ alkali equals 0.00365 gr. HCl. If, for example, 100 c.c. of gastric juice require 50 c.c. $\frac{N}{10}$ alkali to neutralise it, the acidity in terms of HCl will be 0.1825. In other words, the percentage of acid will be equivalent to 0.1825 HCl.

2. **Total Hydrochloric Acid** (*i.e.* the free HCl + the HCl combined with protein).—10 c.c. of filtered gastric contents are placed in a platinum dish and evaporated to dryness on the water bath. The dish is then heated to a low red heat, so that charring is complete, but the resulting carbonaceous material is not burnt up. The mineral chlorides alone now remain in the dish. The contents of the dish are rinsed with hot distilled water through a funnel into a 100 c.c. measuring flask. The flask is cooled, 5 c.c. nitric acid and 20 c.c. $\frac{N}{10}$ silver nitrate solution are added, and the contents made up to 100 c.c. The amount of silver nitrate used in precipitating the chloride present is then determined by Volhard's method (see p. 434). A similar experiment is performed with the same volume of the gastric contents, to which slight excess of sodium carbonate solution is added before evaporation, and again the amount of silver nitrate used in precipitating the chloride determined. The first experiment gives the mineral chloride present, equivalent, say, to 5 c.c. $\frac{N}{10}$ silver nitrate. The second experiment gives the total chloride, equivalent, say, to 10 c.c. $\frac{N}{10}$ silver nitrate. The difference gives the volatile chloride, that is, the hydrochloric acid free and combined with protein. In the hypothetical case this is $10 - 5 = 5$ c.c. $\frac{N}{10}$ silver nitrate. The gastric contents, therefore, contain $\frac{0.365 \times 5}{10}$ per cent. total hydrochloric acid.

Normal human gastric contents obtained after a meal containing very little protein usually contain about 0.2 per cent. total hydrochloric acid. This hydrochloric acid determination is of value, as it is the best measure of the secretory activity of the gastric mucous membrane in pathological conditions.

3. **Free Hydrochloric Acid.**¹—This can be approximately determined by titrating 10 c.c. gastric juice with $\frac{N}{10}$ caustic soda, using Günzberg's reagent as

¹ In testing for free HCl in solutions containing protein, it is important to bear in mind that the HCl will gradually become combined with the protein. The solutions should therefore not be allowed to stand for long before testing them.

indicator. In doing this, the gastric contents are mixed with the standard alkali in a small evaporating dish, samples of the mixture being removed with a glass rod for testing with the reagent.

It is from the glands of the cardiac end of the stomach that the hydrochloric acid is secreted. These glands differ from those of the pyloric end in having parietal as well as central cells, and there is much evidence to show that it is the special function of the former to separate the hydrochloric acid from the blood. After the injection of solutions of neutral salts of iron into the blood, the parietal cells, when treated with potassium ferro-cyanide solution, turn blue, because of the formation of Prussian blue in them. No other cells in the body show this reaction, because they do not contain the necessary acid.

The Organic Matter.—If pure gastric juice be cooled to 0° C., a precipitate falls down. On analysis, this precipitate is found to have nearly the same percentage composition as protein; and on testing its action on a solution of protein, it is found to be pepsin. Pepsin of similar composition can also be prepared by saturating gastric juice with ammonium sulphate, which precipitates it. Whether the actual ferment pepsin is what we obtain by these methods is uncertain. The methods employed for obtaining ferment from the gastric mucosa after death yield a still more impure product, on account of the ferment adhering to the proteoses, etc., which are always present in the final precipitate.

To Prepare an Extract of Gastric Mucosa containing large quantities of Pepsin, the thoroughly washed stomach of the pig is taken, and the mucosa is scraped off with a knife. The scrapings are mixed with a large excess (100 times their bulk) of 0·4 per cent. hydrochloric acid, and the mixture is digested for several hours in the incubator. The extract is then filtered through muslin, and may be employed for general work without further purification. In order to separate the pepsin from the excess of proteoses which this extract contains, the digestion should be allowed to proceed for several days longer, so that the proteoses may become changed into peptones. The product is then saturated with ammonium sulphate crystals; the resulting precipitate of proteoses, which carries down the pepsin with it, is pressed free of fluid, and again incubated for a few days with several volumes of 0·5 per cent. hydrochloric acid, after which the digest is again saturated with ammonium sulphate. This final precipitate is approximately pure pepsin. The ammonium sulphate can be removed from the preparation by dialysis through parchment.

The scrapings of mucosa, after being treated with weak acid to convert the pepsinogen into pepsin, can also be extracted with glycerin. This is the method which is most used commercially. The various commercial preparations of pepsin are very suitable for the experiments about to be described.

Prior to its secretion, pepsin exists in an inactive form as granules in

the gland cells of the stomach mucosa. This precursor or zymogen (see p. 388) is called pepsinogen. It differs from pepsin in that alkali does not destroy it, whereas alkali destroys pepsin.

ADVANCED EXPERIMENT. Scrape off the mucosa from about three square inches of the stomach, grind it with some sand in a mortar, and gradually add about 20 c.c. of 1 per cent. sodium carbonate solution. Filter. When about 10 c.c. of filtrate has collected—which will take some time on account of the mucilaginous nature of the extract—place a piece of washed fibrin in the filtrate and incubate at body temperature. No digestion occurs. In half an hour add 3 per cent. HCl, drop by drop, to the solution until it reacts faintly acid towards litmus and again incubate. The fibrin soon digests. The acidity has converted pepsinogen into pepsin. Divide the resulting solution into two parts. To one of these add 1 per cent. sodium carbonate solution until faintly alkaline, and set aside at warm temperature for 15 minutes, after which again render it faintly acid with 3 per cent. HCl. To both test tubes now add similar pieces of fibrin and warm to body temperature. It will be found that the fibrin becomes quickly digested in the tube, which has been kept at acid reaction, but not in the other tube, because of the alkalinity of the solution having destroyed the pepsin. Pepsinogen, therefore, withstands an alkaline reaction, but pepsin is destroyed.

The most favourable conditions for the action of pepsin may be studied in the test tube as described in the following experiments :

The Action of the Gastric Juice.—The most convenient protein for studying the action of pepsin is blood fibrin which has been very thoroughly washed with boiling acidulated water so as to remove all impurities. Cubes of coagulated egg white may also be employed, but they digest more slowly than fibrin.

EXPERIMENT VII. Label six test tubes *A, B, C, D, E, F*, and place a small piece of fibrin in each. Half fill *A* with water, *B* with 0.2 per cent. HCl, *C* with water and a few drops of peptic extract, *D* with 0.2 per cent. HCl and a few drops of peptic extract,¹ *E* same as *D*, but boil the mixture, and *F* with 1 per cent. sodium carbonate solution and a few drops of the peptic extract.

Place all these in a water bath kept constantly at body temperature (37-38°). Observe that in *A* the piece of fibrin remains unchanged, whereas in *B, D*, and *E*, which all contain 0.2 per cent. HCl, it becomes swollen and transparent. In *F*, which contains alkali, it does not swell.

EXPERIMENT VIII. After about half an hour, remove a sample of the contents of any of the tubes containing acid, colour it faintly with a drop or two of litmus solution, and then carefully neutralise with weak sodium carbonate solution (1 part 1 per cent. sodium carbonate + 2 parts of water). A precipitate of acid meta protein or syntonin is usually produced (for reactions, see proteins, p. 310).

¹ Use larger quantities of fibrin and fluid in this test tube, because the products of digestion will be required for succeeding experiments.

The first stage in gastric digestion of proteins consists, therefore, in the production of acid meta-protein by the weak HCl. As we shall see later, this preliminary change is necessary before pepsin can further hydrolyse the protein.

EXPERIMENT IX. Remove a sample of the contents of *D* and apply the following tests:—(a) The Biuret reaction—rose-pink colour; (b) Add nitric acid (conc.)—white precipitate, which clears up on heating and returns on cooling; (c) Add a few drops of a saturated solution of salicyl sulphonic acid. A white precipitate results which disappears on heating and returns on cooling. These results show us that proteoses have been produced (see p. 310).

The production of proteoses constitutes the second stage of peptic digestion, and it is the pepsin which produces the change. If samples of any of the other test tubes than *D* be examined, no proteose will be found, either because no pepsin has been present (as in *A* and *B*), or because, though present, its action has been destroyed by heat (as in *E*), or there has been no acid present to produce syntonin and help its action (as in *C* and *F*).

There are two principal varieties of proteoses developed, namely “primary” and “secondary”; the former are precipitated by half saturation with ammonium sulphate, the latter begin to be precipitated at two-thirds saturation with this salt.

EXPERIMENT X. Take a sample of a peptic digest of two days' duration. Heat this to near boiling point, and add ammonium sulphate crystals till no more will dissolve. Now change the reaction of the fluid to alkaline and allow to cool.¹ Filter and test the filtrate for Peptone.

1. By Biuret reaction—(remember to add a large excess of caustic alkali, so that more than is sufficient to decompose the ammonium sulphate may be present in the fluid)—rose-pink.

2. By nitric acid or salicyl sulphonic acid tests—no precipitate.

In peptic digestion some of the protein is always further broken down to amino acids.

Method of Separation of Products of Gastric Digestion.—Fibrin is boiled first with tap water, and then with 0.1 per cent. hydrochloric acid to purify it. It is placed for 1.2 hours in an incubator along with five times its bulk of 0.2 per cent. hydrochloric acid and a sixth its bulk of commercial peptic extract. (A solution of Witte's peptone may also be employed).

The products of digestion can be separated from this digest by the following process:—

¹It is only by thus saturating in the heat, both in acid and alkaline reaction, that all traces of secondary proteoses are precipitated.

(1) Boil the solution in a beaker or evaporating dish, cool and separate any coagulated native protein by filtration.

(2) Carefully neutralise the filtrate with 1 per cent. sodium carbonate solution ; if a precipitate of metaprotein (syntonin) falls down, separate it by filtration.

(3) The resulting filtrate is now shaken vigorously with an equal volume of a saturated solution of ammonium sulphate. A precipitate of *primary proteoses* forms since these are insoluble in half saturated ammonium sulphate solution. Collect the precipitate on a filter paper and preserve the filtrate. The further investigations of the precipitate and filtrate are conducted simultaneously. The *precipitate* is washed at least once with a half-saturated solution of ammonium sulphate, the filter paper floated on to water in an evaporating dish stirred up with a glass rod, warmed, and portions of the resulting solution of primary proteoses (containing ammonium sulphate) employed for the following tests :—

1. Add a few drops of a saturated solution of salicyl sulphonic acid—a white precipitate forms which dissolves on heating and reappears on cooling.

2. Add a few drops of pure concentrated nitric acid. The same result is obtained as in 1.

3. Apply the Biuret test using a sufficiency of 20 per cent. caustic soda solution to permit of some excess after all the ammonium sulphate has been decomposed (see p. 31)

4. Apply the various protein tests described on pp. 302, 303.¹

The filtrate still contains the secondary proteoses. These are precipitated by adding sufficient sulphuric acid to the filtrate to render it distinctly acid towards litmus, saturating while boiling with ammonium sulphate crystals, adding ammonia till just alkaline and allowing to cool. The precipitate is then filtered off, dissolved in water, and the tests described under primary proteoses applied to the solution. The precipitates with nitric acid and salicyl sulphonic acid will be much less marked than with primary proteoses.

The filtrate after removal of the last traces of proteose is tested for peptones by applying the Biuret test with excess of caustic soda, and other general protein tests.

For convenience in testing the large amount of ammonium sulphate present may be removed by boiling the solution, adding barium carbonate as long as ammonia continues to be evolved, and filtering.

The table on page 386 shows the main reactions of the intermediate products of peptic digestion (as occurring in Witte's Peptone) compared with those of native protein. (See also p. 312.)

The action of gastric juice in curdling milk is described in the section on Milk (see p. 327). This action is usually attributed to the ferment rennin, but it is probable that rennin and pepsin are identical, as proteolytic ferments always have a rennin action, and the proteolytic activity of a given ferment is proportional to its rennin activity.

The gastric juice scarcely affects other foodstuffs. In the case of fat, however, it dissolves the protein envelope of the fat cell, and liberates the contents, which now float in the chyme as oil globules. On emulsified fats the gastric juice can effect hydrolysis into fatty acid

¹ The alkaloidal reagents give precipitates with proteoses.

Name of protein.	Precipitation limits with $(\text{NH}_4)_2\text{SO}_4$, expressed in percentage saturations.	Solubility in alcohol.	Salicyl sulphonic acid and HNO_3 tests.	Biuret test.	Millon's reaction.
Native protein.	Globulins ($\frac{1}{2}$ sat.). Albumins (sat.).	Relatively insoluble.	Ppte., becoming coagulum on boiling.	Violet.	Positive.
Acid meta protein.	—	—	Do.	Do.	Do.
Primary proteose.	24.42 per cent. ($\frac{1}{2}$ sat.).	Hetero-insoluble in 32 per cent.; proto-soluble in 80 per cent.	Ppte., clearing up on boiling and returning on cooling.	Rose pink.	Feeble with hetero-; strong with proto-proteose.
Secondary proteose A	54.62 per cent. ($\frac{2}{3}$ sat.).	Partly insoluble in 70 per cent.	Do.	Do.	Positive.
B ¹	70.95 per cent. (practically sat.).	Part insoluble in 35 per cent.; part soluble in 80 per cent.	Do.	Do.	Positive. ¹
C	100 per cent. plus acid.	Soluble in 68-80 per cent.	Do.	Do.	Absent.
Peptones.	Not precipitable.	A insoluble in 96 per cent.	Negative.	Do.	Absent.
		B soluble in 96 per cent.	Negative.	Do.	Present.

and glycerine in virtue of a *lipase* which is secreted by the gastric glands.

Method of Estimating Activity of Pepsin Solutions. (1) **Grutzner's Method (Approximate).**—Fibrin, purified as above described, is stained with carmine solution, and washed free of adherent stain. Equal weighed quantities are then placed in two test tubes, and 10 c.c. of 0.2% hydrochloric acid are added to each. Equal quantities of the pepsin solutions which it is desired to test are added, and the tubes placed in the incubator. As the fibrin becomes digested the carmine is liberated, and stains the solution. The more deeply stained solution, therefore, contains the stronger ferment. The exact amount of carmine liberated may be determined by comparing the digests with an artificial scale consisting of ten solutions of carmine of different known strengths. A control of 0.2% HCl and carmine fibrin ought also to be studied.

(2) **Mett's Method.**—A narrow glass tube 1 to 2 mm. in diameter, and drawn

¹ Proteose B can be fractionated into various sub-varieties which differ from one another in their elementary composition and somewhat in their reactions. There is one variety of proteose B which gives no reaction with Millon's reagent.

to a fine point at both ends, is filled with egg white, the ends closed in the flame, and the tubes then heated so that a column of coagulated albumin is obtained. It is then cut into segments of equal length, and two of these are placed in a test tube which contains the pepsin solution acidified with 0.2% hydrochloric acid. Two similar tubes are placed in another test tube with the other pepsin solution. Both are placed in the incubator for several (10) hours. The length of dissolved protein column is then measured in both cases, and the desired result is obtained by squaring this distance.

Thus if in one test tube the length were 2, and in the other 3, the strength of the two pepsin solutions has the ratio of 4 to 9.

This method is only accurate when weak pepsin solutions are used. If more than 4 mm. of protein are digested, the estimation must be repeated with diluted solutions.

CHAPTER XIV.

DIGESTION IN THE INTESTINE.

IN about half an hour after the food enters the stomach, small portions of it begin to pass through the pyloric sphincter into the duodenum. These have undergone gastric digestion and constitute chyme. This leakage goes on until the stomach has completely emptied itself, the length of time necessary for this (3-10 hours) varying with the quantity and quality of the food, and with the activity of the gastric juice.

The chyme, as it leaves the stomach, is strongly acid in reaction to all indicators. In the duodenum, it becomes mixed with the secretions of Brunner's glands and with those of the pancreas and liver, which latter are poured into that portion of the intestine by one common duct, and, as it travels on to the jejunum, it also becomes gradually mixed with the intestinal juice, secreted from Lieberkühn's follicles. These various secretions are alkaline in reaction, in consequence of which the acid of the chyme becomes neutralised, so that the contents of the lower portion of the duodenum and of the upper portion of the jejunum become alkaline in reaction to litmus. Although the acidity of the gastric juice prevents the growths of organisms in it, it does not kill their spores, and these are carried into the intestine along with the chyme. When this latter becomes alkaline, however, the conditions are very favourable for organismal growth, and the spores become transformed into the active organisms which multiply quickly, meanwhile receiving their nourishment from the half-digested foodstuffs. In this way the organisms assist the digestive juices in decomposing the foodstuffs. Among the products of this organismal growth are several organic acids, so that the food, before it has gone far along the intestine,

again becomes acid in reaction towards litmus. The mucosa of the large intestine does not secrete any digestive juices, its sole function being one of absorption. In its passage along it the fluid of the intestinal contents becomes gradually absorbed, and the unabsorbed residue forms the faeces.

It will be seen, therefore, that there are four distinct digestive agencies at work in the intestine, and we will now study the action of each of these separately.

The Pancreatic Juice. *Composition.*—This can be collected by producing a fistula of the pancreatic duct. The juice is strongly alkaline in reaction, gives a coagulum of protein on boiling, and contains, besides protein, a considerable amount of organic matter.

Its percentage composition varies very much with the method adopted for collecting it, that obtained immediately after the establishment of the fistula being very much richer in solids than that secreted a few days later.

	Directly after operation.	Permanent fistula.
Water,	90·08	97·68
Total solids,	9·92	2·32
Organic,	9·04	1·64
Inorganic,	0·88	0·68

In studying its digestive action we may employ, as in the case of gastric digestion, an extract of the gland. This extract may be made with glycerine, after treating the minced gland with weak acid, or allowing it to stand some time, so as to convert the zymogens into the active ferments. Glycerine does not extract all the ferments, however, so that it is more usual to employ the minced gland itself, or a watery extract of it.

The secretion of pancreatic juice is stimulated by the presence in the blood of a substance called secretin. Secretin is produced in the epithelial lining of the small intestine by the action of weak acids on it. Thus, if some of the inner lining of the small intestine be scraped off and ground in a mortar with fine sand and 0·4 % HCl, and the resulting mixture boiled, neutralised and filtered, a solution is obtained which, when injected intravenously into an anaesthetised animal with a pancreatic fistula, causes an immediate and abundant secretion of pancreatic juice. The secretin does not exist preformed in the intestinal epithelium, for a saline extract of this, when similarly injected, has no effect on pancreatic secretion.

The pancreatic juice thus secreted differs in its digestive properties from an extract of pancreas. The chief difference lies in the fact that

it can digest proteins only feebly, because it does not contain active trypsin but only its zymogen trypsinogen. To convert the trypsinogen into trypsin, mixture with succus entericus is necessary. The succus entericus contains a substance called enterokinase which activates the trypsinogen.

There are three active ferments in pancreatic juice, one proteolytic—trypsin; one amylolytic—amylpsin or amylase; one steatolytic—steapsin or lipase.

I. Trypsin.—Like pepsin, this ferment hydrolyses protein, and leads to the production of proteoses and peptones. In this case, however, digestion is more complete. Under suitable conditions the proteoses and peptones can disappear entirely, polypeptids, amino acids and hexone bases resulting; the ultimate decomposition products are, in fact, almost the same as when a strong acid is used as the hydrolysing agent (see Proteins, p. 299).

EXPERIMENT I.—A solution of pancreatic extract in 1% sodium carbonate is prepared (*Liq. Pancreaticus* (Benger), diluted thirty times with 1% sodium carbonate solution). In order to study the action of this on proteins, add to it a piece of fibrin which has been soaked over night in 1% sodium carbonate solution, and place on a water-bath at body temperature.

The following points of difference may be noted between this and the peptic digestion of fibrin: (1) The reaction is alkaline; (2) there is no preliminary swelling of the fibrin; it is gradually eaten away (erosion); (3) when the piece of fibrin has nearly disappeared remove a sample of the digest, and neutralise with weak acetic acid. A precipitate of alkali metaprotein results (for Reactions, see p. 310).

Apply to another sample the tests for proteoses and peptones, and note that they are positive.¹

EXPERIMENT II.—If the pancreatic extract in Experiment I. be boiled before the fibrin is added, no digestion will result. The digestive agent is, therefore, a ferment which is destroyed by heat.

EXPERIMENT III.—Repeat Experiment I., making the reaction acid by means of hydrochloric acid. Note that, although the fibrin becomes swollen up—as this depends on the acid, not on the ferment—no formation of proteoses or peptone occurs. The trypsin cannot act in acid medium, being destroyed in this reaction.

(4) Trypsin can carry digestion further than pepsin.

Leucin, Tyrosin and the other Products of Tryptic Digestion.—During digestion of protein by trypsin a number of amino acids are

¹No primary proteose is formed by tryptic digestion; there is, however, a considerable amount of secondary proteose (see p. 386).

produced, of which leucin and tyrosin are examples. An amino acid is derived from an organic acid (containing therefore the $-COOH$ group) by the substitution of one of the hydrogen atoms attached to a carbon atom of the chain (*e.g.* CH_2- , $=CH-$) by the amino group (NH_2).

Thus acetic acid has the formula CH_3COOH .

If one of the "H's" of the CH_3 group be displaced by NH_2 , the result is $NH_2 \cdot CH_2 \cdot COOH$, which is amino acetic acid, also called glycine and glycocoll.

Glycine is formed during the digestion of gelatine and globulin, but not of albumin. It also exists in the bile, where it enters into the formation of one of the bile salts (*e.g.* glycocholate of soda is glycine + cholalic acid). It likewise occurs in combination with benzoic acid, as hippuric acid, in the urine of herbivorous animals, and to a less extent in the urine of man.

The amino acid corresponding to the next acid of the acetic acid series, viz. propionic acid $CH_3 \cdot CH_2 \cdot COOH$ is aminopropionic acid, or alanin, $CH_3 \cdot CHNH_2 \cdot COOH$. In the free state it is only produced from a few proteins,¹ and is unimportant, but it is frequently combined with phenol, the resulting compound being tyrosin. If in the formula of phenol the H atom in the para position to the OH group be replaced by amino propionic acid, para-hydroxyphenylamino-propionic acid, or tyrosin results. It, therefore, belongs to the aromatic group of organic bodies, and because it contains hydroxyphenyl (the radicle of phenol) it reacts red with Millon's reagent (see Proteins, p. 302).

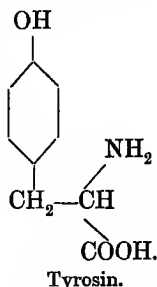

EXPERIMENT IV. Add Millon's reagent to some pancreatic digest; a white coagulum of proteins results. Filter. Boil the filtrate. It turns red, because it contains tyrosin.

EXPERIMENT V. Examine the crystals of tyrosin supplied you under the microscope, and note that they consist of fine needles grouped into star-shaped masses (Fig. 236).²

There are no other important amino acids till we come to the member of the series which contains six carbon atoms, viz., caproic

¹ By the hydrolysis of haemoglobin, however, alanin is a very abundant decomposition product.

² A body very closely related to tyrosin in its chemical structure has recently been described amongst the products of hydrolysis of proteins by acids. This is phenylalanin, differing from tyrosin only in that it does not contain the phenolic OH group. It has also been discovered in the products of the prolonged action of pepsin on proteins.

acid. The amino acid of this is closely related to *leucin*. It has recently been shown, however, that the true constitution of leucin is not amino-caproic acid but rather amino-isobutylacetic acid $(\text{CH}_3)_2\text{CH} \cdot \text{CH}_2 \cdot \text{CHNH}_2 \cdot \text{COOH}$.

EXPERIMENT VI. Examine crystals of leucin under the microscope and note that they consist of round balls not unlike oil globules yellowish in colour, and usually having concentric markings (Fig. 236).

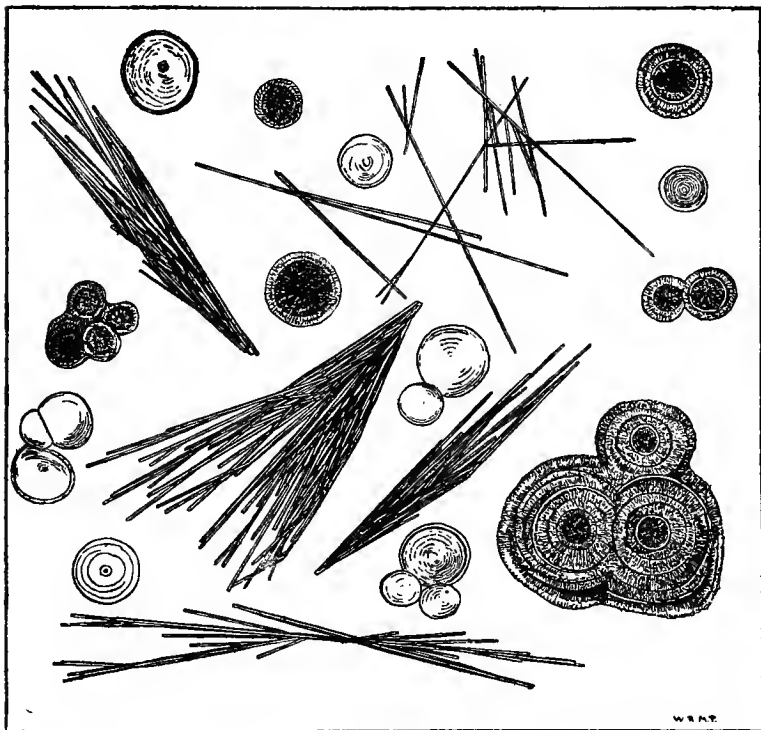
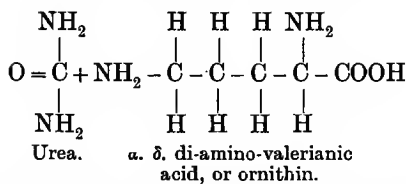

FIG. 236.—Crystals of leucin and tyrosin.

Leucin and tyrosin were among the first-discovered composition products of proteins, and, on account of the ease with which they are isolated, they have been detected in nearly every organ and tissue of the body, being probably produced, however, by the chemical agencies employed in examining these, and not existing as such in the living tissue. They also occur, along with excess of ammonium salts, in the urine of patients suffering from severe disease of the liver.

Not only are amino derivatives of mono-basic acids produced during protein decomposition, but we may also have similar derivatives of



Histidine ($\text{C}_6\text{H}_9\text{N}_3\text{O}_2$) differs essentially from the above so-called hexone bases in containing a ring formation of atoms in the molecule. It is believed to be α -amino- β -imidazol propionic acid :

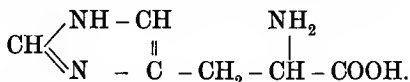

A product of some interest is *cystin* :— $\text{COOH} \cdot \text{CHNH}_2 \cdot \text{CH}_2 \cdot \text{S} \cdot \text{S} \cdot \text{CH}_2 \cdot \text{CHNH}_2 \cdot \text{COOH}$. It is converted into cystein by reduction. Cystein is α -amino- β -thiolactic acid :— $\text{SH} \cdot \text{CH}_2 \cdot \text{CHNH}_2 \cdot \text{COOH}$. It is, therefore, closely related to alanin ($\text{CH}_3 \cdot \text{CHNH}_2 \cdot \text{COOH}$) or amino-propionic acid. Cystin is probably the source of the taurin of bile, and is the chief sulphur-containing constituent of protein.

By reference to the table on p. 299 it will be seen that trypsin produces much the same decomposition products as strong acid. Certain parts of the protein molecule, however, resist the action of trypsin for a long time, such, for example, as those which contain the pyrrolidin-carboxylic acid and phenylalanin groups. Between the peptones which give the Biuret test and the amino bodies are several lower peptones or polypeptids which do not give this test.

To isolate and identify the various products of tryptic digestion of protein would consume far too much time and require too great a bulk of material to make it practicable as a class exercise. Two of the commonest degradation products, viz. leucin and tyrosin, can, however, be isolated with comparative ease, although even for this purpose a considerable bulk of material is required. A method for the isolation of tryptophane is also described.¹

ADVANCED EXPERIMENT.—Mince up a pig's pancreas thoroughly, and shake it in a flask with 500 c.c. of water containing 3 c.c. of a saturated solution of sodium carbonate, and 3 c.c. of chloroform. Add also about 200 grams of blood fibrin, which has previously been soaked in 1% sodium carbonate solution. Place the flask in an incubator at body temperature, and after three days test the reaction of the digest towards litmus. If acid, add more sodium carbonate till distinctly alkaline. Also remove about 10 c.c. and filter into a test tube. To this sample carefully add a few drops of bromine water. A violet colour results, the intensity of which should be carefully noted. This colour reaction is due to tryptophane, an aromatic amino acid which is liberated by the action of trypsin (see p. 395).

¹These exercises are introduced here for the benefit of the more advanced students. They should, however, be read by the junior student as well.

Test the reaction towards litmus and the intensity of the tryptophane reaction on each succeeding day. When the tryptophane reaction becomes very intense (in about five days) proceed to isolate leucin and tyrosin in the following manner:—

The digest is rendered faintly acid with acetic acid, boiled and filtered hot. A sample of the filtrate is removed and tested for proteose. A negative result is usually obtained.

1. **Separation of Tyrosin.**—The remainder is evaporated on the water-bath to a thin syrup. This is allowed to stand on ice or in a cold place for several days. White flocculi of *tyrosin* separate out. These are filtered through fine muslin, and removed to a beaker by means of a jet of cold distilled water and washed several times with distilled water by decantation. They are then dissolved by boiling with water made alkaline by the addition of a few drops of ammonia, and the resulting solution is quickly filtered hot. The filtrate is heated till all the ammonia is expelled; it is then cooled, when the tyrosin separates out as a white precipitate. This is collected on a filter paper, washed, and dried. The following *reactions* may be applied to the resulting powder:—

(1) Tyrosin is insoluble in cold water, slightly soluble in hot water, and very soluble in dilute alkali.

(2) A solution in hot water gives a red colour on the addition of Millon's reagent. This is because tyrosin contains an aromatic radicle (p. 390).

(3) *Piria's Test.*—Place some of the powder in a dried test tube, add about 2 c.c. concentrated sulphuric acid, and place the test tube in a boiling water-bath for half an hour. Now cool and dilute with water, transfer to an evaporating basin, and remove the sulphuric acid by adding powdered barium carbonate; filter off the barium sulphate, evaporate the filtrate to small bulk, and add a drop or two of very weak ferric chloride solution. A violet colour results. This reaction is due to the formation of tyrosin-sulphuric acid.

2. **Separation of Leucin.**—The tyrosin-free filtrate is evaporated till a skin of leucin forms on the surface. It is then mixed while still warm with several times its bulk of alcohol, whereby a precipitate (previously known as antipeptone) separates out, which after cooling can be removed by filtration. This precipitate consists of a mixture of several bodies, including lysine, histidine, and arginine. The filtrate is evaporated on the water-bath until all the alcohol has been driven off. It is then boiled with lead carbonate and filtered. The lead is removed from the filtrate by means of H_2S , the PbS separated by filtration, and the final filtrate accurately neutralised with weak NaOH. By now concentrating by evaporation on the water-bath and cooling *leucin* will separate out.

Reactions of Leucin.—(1) It is much more soluble in water than is tyrosin; it is soluble also in alcohol.

(2) When heated in a piece of dry glass tubing, a sublimate forms on the cool parts of the tube.

(3) Like other amino acids, it gives off ammonia gas when heated in a test tube with a piece of solid caustic potash and a few drops of water. If the melt be cooled, dissolved in water, and then acidified with sulphuric acid, it gives a smell of valerianic acid on heating.

(4) *Scherer's Test.*—Heat some leucin with a drop of nitric acid on a piece of platinum foil, add to the dry residue some caustic potash, when a yellow stain results. Heat still further, and the stain rises up into a globule which runs off the platinum.

(5) Examine a solution of leucin with the polariscope (p. 282). It is *levo*-

rotatory (α)_D—in aqueous solution = -10.8° . The leucin which is obtained by boiling protein with haryta, or that obtained synthetically (by the action of ammonia on α -bromocaproic acid) is *optically inactive*, and the *dextrorotatory* form may be obtained from this by allowing *penicillium glaucum* (a fungus) to grow on a solution of it. The fungus destroys the *levo-rotatory* part, but leaves the *dextro-rotatory*, untouched. Moulds, yeasts and ferments act much more energetically on naturally occurring than on synthetic isomers.

Tryptophane.¹—If bromine water be cautiously added to a tryptic digest of several days' standing a deep violet-red colour will result, and if the mixture be shaken with amyl alcohol, this latter will take up the colour. The glyoxylic reaction (see p. 303) will also be very distinct in the digest even after the Biuret reaction has disappeared (*i.e.* after the proteio molecule has been quite destroyed). Both these reactions are due to tryptophane, which is closely related in its chemical structure to certain of the aromatic substances that are produced by the bacterial digestion of protein.

Separation of Tryptophane.—A large amount (500 gr.) of commercial casein (plasmon or protene) is mixed with liq. pancreaticus (200 c.c. Benger) and 0.8% Na_2CO_3 , and placed in an incubator for about a week. The ferment should be added, half at the beginning and the remainder three or four days later. Antiseptics should be added.

Digestion is allowed to proceed until the bromine water reaction is maximal. The digest is then boiled, cooled and filtered, and H_2SO_4 added to the filtrate, so as to bring the amount of H_2SO_4 in the latter to 5-6%. If any precipitate is hereby formed it should be filtered off. The clear filtrate is then mixed with an excess of an acid solution of mercuric sulphate (10% mercuric sulphate dissolved in 10% H_2SO_4) and filtered. This reagent may precipitate, besides tryptophane, some tyrosin and cystin.

From tyrosin the precipitate is freed by washing it with 5-6% H_2SO_4 , the mercury compound of tyrosin being very soluble in this. From cystin (which is scanty in a digest of casein) the tryptophane is separated by reprecipitation. For this purpose the washed mercury precipitate is suspended in water and decomposed with H_2S gas. To complete this reaction the suspension must be saturated with the gas, then warmed and saturated again. The HgS precipitate is filtered off, the filtrate warmed to rid it of H_2S , then acidified to 5-6% H_2SO_4 , and the mercuric sulphate reagent added to it until a small permanent precipitate is produced. This is mainly cystin, and is filtered off. The tryptophane in the filtrate is then completely precipitated by mercuric sulphate, and the resulting precipitate treated exactly like the first one.

In this way a solution of tryptophane in 5-6% H_2SO_4 is obtained. The H_2SO_4 is now precipitated by adding $\text{Ba}(\text{OH})_2$ water in the heat and filtering. Great care should be taken that the filtrate contains no excess either of H_2SO_4 or of $\text{Ba}(\text{OH})_2$. The watery solution of tryptophane is then mixed with half its bulk of alcohol and evaporated on a water bath. During evaporation small quantities of alcohol are added from time to time to prevent the browning which occurs if watery solutions of tryptophane are heated alone. Evaporation proceeds till

¹ A single digestion mixture may be employed for the separation of leucin, tyrosin and tryptophane, but in such a case both fibrin and casein ought to be added, since casein is the only common protein which yields any large amount of tryptophane. It also contains a considerable amount of tyrosin.

crystallisation commences, when the basin is removed and allowed to stand. The crystals (glistening plates) are collected on a filter, and, to purify them, may be recrystallised.

A solution of the crystals gives the bromine and the glyoxylic reactions very distinctly, and if the crystals be heated in a test tube indol and skatol (see p. 406) are evolved.

Ellinger has shown the constitution of tryptophane to be indolamino-propionic acid; its formula is probably:—

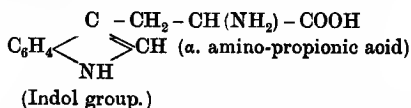

Tryptophane is the mother substance of indol, which, along with its methyl derivative skatol, is largely responsible for the faecal colour. These bodies are produced from tryptophane by bacterial growth (see p. 405).

Preparations of trypsin have a rennin-like action on milk if sufficient calcium be added (see p. 327).

II. Amylopsin, Pancreatic Amylase.—This ferment acts on starch in exactly the same way as ptyalin does—*i.e.* it converts it into maltose and achroodextrin. Unlike ptyalin, it is capable of acting on unboiled starch.

EXPERIMENT VII. Add some glycerine extract of pancreas to some powdered starch. Shake, and place in the water-bath at 37°. Remove drops every half minute, and mix on a slab with a drop of iodine solution. Note the appearance of the dextrine reaction. When this disappears, apply Trommer's test, or one of its modifications, to a sample of the digest; note the reduction due to maltose.

III. Steapsin or Lipase.—This decomposes neutral fat into fat acid and glycerine (see Fats, p. 314).

EXPERIMENT VIII. Some minced pancreas is shaken with water¹ strained through muslin, and the resultant extract divided into two parts. One of these is boiled to destroy the ferment, and is then cooled. To both portions (about 10 c.c. each) are added five drops of melted and filtered butter fat, a few drops of an alcoholic solution of phenolphthalein, and then N/10 caustic soda, until a deep red colour is obtained. After vigorous shaking, so as to obtain a partial emulsion, the test tubes are placed in the incubator, and examined after about half an hour. The lipase-containing fluid will be decolourised (the fatty acid having bleached the phenolphthalein), and, to regain the original red colour, a certain number of c.c. N/10 caustic soda must be added to it. In this way, an approximate estimate can be obtained of

¹Glycerin does not dissolve steapsin, so that a glycerine extract of pancreas is not suitable for this experiment.

the fat-splitting power of the extract. Pancreatic lipase is very readily destroyed in acid reaction, thus making it necessary to employ an absolutely fresh gland from which to prepare the extract.

The liberated fatty acid is held in solution by the bile, and so is absorbed into the epithelial cells of the villi, wherein it recombines with glycerine to form neutral fat.

CHAPTER XV.

THE BILE. BACTERIAL DIGESTION.

THIS is perhaps the most puzzling secretion in the whole of the physiological chemistry. Its digestive action is very slight, so that it would almost appear, at first sight, to be an excretion of effete products rather than a useful secretion. Against such an idea, however, stands the fact that it is poured into the beginning of the intestinal tract, and not into the end of it, as we should expect were it an excretion. Further, some of its constituents are reabsorbed into the portal blood and carried back to the liver, to be re-excreted in the bile. In other words, there exists a circulation of certain biliary constituents, from liver to intestine by the bile, and from intestine back to liver by the portal blood. The absence of this reabsorption of bile constituents into the blood when there is a biliary fistula (produced by attaching the central end of the bile duct to a wound in the abdominal wall) accounts for the bile in such cases containing less solids than the bile obtained from the gall bladder after death. Another reason for this difference in composition is that reabsorption of water occurs in the gall bladder, and that mucin or nucleo-protein are secreted by its mucosa. In the case of a fistula of the bile duct the bile does not collect in the gall bladder.

Composition of Human Bile.—In I. the bile was obtained from the gall bladder of persons who had been accidentally killed, while in good health: in II. the bile was obtained from a fistula during life.

	I.	II.
100 parts contain—		
Water,	86	97
Solids,	14	3
<i>Viz.</i> organic salts,	9	0·9-1·8
Mucin and bile pigment,	3	0·5
Cholesterol,	0·2	0·06-0·16
Lecithin and fat,	0·5-1·0	0·02-0·09
Inorganic salts,	0·8	0·7-0·8

Besides these, bile also contains traces of soaps, fats and urea. Compounds of glycuronic acid have also been found in bile. The daily secretion amounts to about 750 c.c. To study the chemistry of bile we employ that of the ox, since this is easily procurable.

EXPERIMENT I. Examine some ox bile. Note that it has a greenish colour, a peculiar musk-like odour, a bitter-sweet taste, a faint alkaline reaction to litmus paper, and that it is of a slimy consistency.

EXPERIMENT II. If a few drops of weak acetic acid be added to a few cubic centimetres of bile, a stringy precipitate is produced. This consists, in certain animals (ox) of nucleo-protein, in others (man) of mucin. Filter off this precipitate, and note that the filtrate has lost its slimy character. Boil the filtrate; no coagulum is produced, therefore bile contains no native protein.

The above proteins are not produced by the hepatic cells, but are added to the bile in its passage along the bile ducts, being secreted by the mucous lining of these.

So far as can at present be ascertained, the amounts of pigment and of bile salts do not bear a quantitative relationship to one another, so that it is improbable that they are both derived from the same source. Quantitative estimations of these two bodies in bile, obtained from a biliary fistula, are, however, far from numerous, partly on account of the rarity of suitable cases, and partly because there is no accurate method for quantitatively determining the pigment.

EXPERIMENT III. Test another portion of the bile for bile salts by *Pettenkofer's reaction*. To do this place a drop of bile in a small evaporating dish, and move this about so that a thin film of the bile is produced. Now add to the film a very small drop of a concentrated watery solution of cane sugar, and then a few drops of concentrated sulphuric acid. A purple colour is produced, which can be intensified by warming. This pigment shows absorption bands in the spectrum. The chemistry of this reaction is that the sulphuric acid acts on the cane sugar to produce a body called furfuraldehyde, which then reacts with the cholalic acid of the bile salts to produce the pigment. Where only traces of bile salts are present, the test may be made more delicate by using a solution of furfuraldehyde (1 in 1000) instead of cane sugar.

EXPERIMENT IV. *Matthew Hay's Sulphur Test*.—If a small pinch of powdered sulphur be sprinkled on the surface of bile, or of a solution containing bile salts, it will sink to the bottom of the vessel; whereas with most other fluids it remains floating on the surface. This reaction depends on the fact that bile salts lower the surface tension of fluids in which they are dissolved. For comparison repeat this test with water.

The bile salts are two in number, glycocholate and taurocholate of sodium. The two acids (glycocholic $C_{26}H_{43}NO_6$ and taurocholic $C_{26}H_{45}NSO_7$) are very closely related to one another, for they both yield, on boiling with stronger acids, a common non-nitrogenous body called *cholalic acid*, and a nitrogenous body of the nature of an amino acid. The amino acid, which is obtained from glycocholic acid, is *glycin*. The amino acid in taurocholic acid is *taurin*, which is peculiar in that it contains sulphur which can be demonstrated by fusing some taurin (prepared as described below) on a piece of platinum foil with sodium carbonate, dissolving in water, acidifying and heating the resultant solution: sulphuretted hydrogen is given off, which can be detected by holding a piece of filter paper soaked in lead acetate solution over the mouth of the test tube. Taurin is undoubtedly derived from cystin (see p. 393), which when oxidised yields cysteinic acid— $COOH \cdot CHNH_2 \cdot CH_2 \cdot SO_3H$. By the loss of a molecule of CO_2 , this becomes taurin: $NH_2 \cdot CH_2 \cdot CH_2 \cdot SO_3H$. We see, therefore, that both glycin and taurin are derived from protein disintegration, the latter body being one of the forms in which the sulphur of protein is excreted.

Cholalic acid is believed to be related to cholesterol. It has recently been shown to contain two primary alcoholic and one secondary alcoholic groups. There are probably several varieties of it.

The relative amount of these two acids in the bile varies in different animals. In the bile of the herbivora, glycocholic acid is much in excess, whereas in that of many carnivora the only acid is taurocholic. In omnivora (*e.g.* man, etc.) a variable mixture of the two is present. The bile salts are decomposed into their constituents by the action of the bacteria in the intestine. If we examine the faeces, however, no glycin and only a trace of cholalic acid can be detected. The fate of taurin has not been accurately determined.

ADVANCED EXPERIMENT. Separation of Bile Salts.—To Separate the Bile Salts as a Whole. Thoroughly mix 50 gm. pure animal charcoal with 200 c.c. of ox-bile in an evaporating dish, and evaporate the mixture to dryness on a water bath. During the drying the mixture should be frequently stirred. The black powder thus obtained can be kept a considerable time. To extract the bile salts from it, mix it with absolute alcohol in a flask and place the flask on the boiling water bath for about a quarter of an hour, cool, filter into a dry beaker, and add ether to the filtrate till a permanent haze is produced. Now cover the beaker with a ground glass plate, and allow it to stand in a cool place till next day, when it will be found that a crystalline mass of bile salts has separated out (Plattner's Crystalline Bile). The crystals can now be collected on a filter paper and allowed to dry in the air.

A 1% solution of the crystals should now be made, and Pettenkofer's reaction (see p. 398) applied to it by the following method:

Dissolve a few grains of cane sugar in the solution, and run concentrated

sulphuric acid down the side of the tube so as to form a layer underneath the watery solution. A violet ring is formed where the two fluids meet. Now place the test tube in a beaker of cold water, and shake gently so as to mix the two fluids. A violet solution is thus obtained. (By cooling the test tube in water too great a rise of temperature is avoided). Divide the violet solution into two parts, A and B. Add A to some ether and examine by means of the spectroscope—a distinct band is seen in the green. Add B to some absolute alcohol and note that, although the spectrum is at first the same as in A, a band gradually develops in the blue, and that, along with the development of this, the tint of the solution changes from violet to brown.

ADVANCED EXPERIMENT. To Prepare Pure Glycocholic Acid.—In certain districts of Germany and America it has been observed that the glycocholic acid can be separated from the bile by a very simple process, and, so far as it has as yet been tried, the bile obtained from oxen reared in this country appears to be suitable for the process. The method is as follows:

Some ox bile is placed in a stoppered cylindrical vessel, and mixed with ether and hydrochloric acid in the proportion of ten parts of the former and four parts of the latter, for every hundred parts of bile. A few crystals of glycocholic acid are added to the mixture so as to start the crystallisation, the vessel is stoppered, vigorously shaken, and then allowed to stand in a cool place. After some time the mass will be found to be "solid" with crystals. These are collected in a filter paper, and washed with cold distilled water till no more pigment can be removed. They are then removed to a flask and dissolved in boiling water; the solution is filtered hot, and the filtrate, on cooling, deposits numerous acicular crystals of the acid. These may now be collected, washed with distilled water, and dried (for Chemistry and Reactions, see p. 398).

Preparation of Taurin.—Bile from carnivorous animals—cat or dog—is heated on a sand-bath with one-third its bulk of concentrated hydrochloric acid until a resinous-like mass of the anhydride of cholalic acid (called Dyslysin) has formed. This can be drawn out into brittle threads by means of a glass rod. The dyslysin is filtered off, and the filtrate is evaporated to a small bulk, the sodium chloride, which crystallises out during the evaporation, being removed by filtration. The thin syrup is then poured into fifteen times its bulk of alcohol, and left standing twenty-four hours, when the taurin will have crystallised out. It can be purified by collecting the crystals on a filter paper, and washing with cold water.

The Bile Pigments.—These are bilirubin and biliverdin. The former occurs most plentifully in the bile of carnivorous, the latter in that of herbivorous animals. Their presence can be detected by oxidising a mixture containing them with nitrous acid, when a play of colours—green, blue, purple, and then yellow—is produced. This is called Gmelin's test.¹

EXPERIMENT V. Dilute some ox bile with an equal amount of

¹This test depends on the various colours of the oxidation products of bilirubin. The first oxidation product is bili-verdin, which is green; the next is bili-cyanin, which is blue; the next is bili-purpurin, which is purple; and the last is choletelin, which is yellow.

water. Hold the test tube as nearly horizontal as possible, and allow some fuming nitric acid to run down it, so that this forms a layer under the bile. Where the two fluids are in contact, a play of colours is produced. This test can be rendered still more delicate by filtering a little diluted bile through white filter paper, then removing and opening out the filter paper and placing a drop of fuming nitric acid on it.

Bilirubin is the least oxidised bile-pigment, and its empirical formula is $C_{32}H_{36}N_4O_6$. If we compare this with the formula of haematin— $C_{32}H_{32}N_4O_4Fe$ —we see that it must be from this body that it is derived, the change being the abstraction of iron and the addition of two molecules of water. This is also the formula of iron-free haematin or haematoporphyrin, and of haematoidin, a pigment which crystallises out in old blood clots in the tissues. Although the same empirically, these bodies vary somewhat in their physical behaviour, and neither of them gives Gmelin's test, so that we may assume that they have different constitutional formulae.

When it reaches the intestine, the bile pigment is converted by bacteria to another pigment called stercobilin. Some of this pigment is absorbed into the portal blood along with the bile salts. This reabsorbed stercobilin is mainly re-excreted in the bile, but a small quantity is excreted in the urine, where it goes by the name of urobilin (see Urine). Stercobilin forms the principal colouring matter of the faeces.

EXPERIMENT VI. Bilirubin can be extracted from pigmented gall-stones. The gall-stones are ground to a rough powder and extracted by heating with 95 % alcohol, to which a few drops of strong hydrochloric acid have been added. (The acid is necessary to decompose the compound of bile pigment with calcium present in the stones.) The coloured extract is then cooled. The crystals of cholesterol, which separate, are filtered off, washed with alcohol and examined. (See p. 318.) The filtered extract is placed in a dish, and pure nitric acid run in, drop by drop, when a brilliant Gmelin's test is obtained.

Lecithin ($C_{44}H_{90}NPO_9$) and **Cholesterol** ($C_{27}H_{46}OH$) (see Chapter VI.).—These two bodies are kept in solution in the bile by means of the bile salts. For their separation, see p. 316.

EXPERIMENT VII. Place some bile in a test tube, and add one or two crystals of cholesterol to it and gently warm. The cholesterol dissolves. Before doing this show that the crystals will not dissolve in water.

Both lecithin and cholesterol are excretory products. The tissues which contain the highest percentage of them are the nervous, so that

the bile functionates as the channel by which the products of nervous metabolism are removed.

Inorganic Salts.—These are chiefly sodium carbonate and disodium hydrogen phosphate.

The Uses of the Bile in Intestinal Digestion.—(1) It is an alkaline fluid, containing a viscid substance (mucin, etc.); consequently, it assists in the emulsification of fats.

EXPERIMENT VIII. Shake up some rancid oil with bile in a test tube. Notice that a very stable emulsion is formed. (See Fats, p. 316.)

(2) It causes a precipitate when added to an artificial peptic digest.

EXPERIMENT IX. Add some bile to a sample of a 24 hours' peptic digestion of egg-white. A precipitate of proteins is produced.

It is claimed that by this precipitation the fluid chyme becomes much thicker, and its condition, therefore, rendered more favourable for being further digested in the intestine, since it will adhere to the intestinal wall.

(3) It dissolves the free fatty acid produced in the intestine.

On account of this latter action, and, to a certain extent, on account of its emulsifying powers, bile assists materially in the absorption of fat. Where bile is not excreted into the intestine (as in Jaundice), the faeces become rich in fatty acid, in consequence of which they appear greasy and pale in colour. The presence of excess of fatty material in the intestinal contents also hinders protein digestion to a certain extent, by coating the particles of food and preventing the juices getting at them. In consequence of this, bacterial growth becomes excessive when there is suppression in the secretion of bile. It is by this means that bile diminishes putrefaction in the intestine, and not on account of any antiseptic properties it possesses, for bile itself quickly becomes putrid on standing. Many other properties have been ascribed to bile, *e.g.* that it assists the absorption of oil globules and that it acts as a laxative, but these are not of much importance. It may be mentioned that in some animals bile contains a diastatic ferment. The secretion of bile by the liver is stimulated by the intravenous injection of secretin. It also activates, to a certain extent at least, the lipolytic ferment of pancreatic juice.

To sum up, we may state that, although bile contains no ferment by which a chemical change can be produced on any of the food-stuffs, it is nevertheless of great value as a digestive fluid, in that it assists the pancreatic juice: (1) by neutralising the chyme; (2) by activating pancreatic lipase; (3) by dissolving the fatty acid produced by the action of lipase; (4) by assisting in the emulsification of neutral fat; (5) by assisting the absorption of fat; and consequently (6) of allowing

protein to be attacked by trypsin, thereby diminishing bacterial growth and consequent putrefaction; (7), and lastly, by precipitating the half-digested products of chyme, so that the trypsin may the better act on them.

Intestinal Juice. Succus Entericus.—This is secreted by Lieberkuhn's follicles. It may be obtained pure by isolating a piece of intestine and collecting the juice secreted by it. This may be accomplished by cutting out a piece of intestine and stitching both ends to abdominal fistulae (Vella's method), the severed ends of the intestine being sutured together. Or one end of the isolated piece may be sutured, the other being attached to a fistula (Thiry's method). In both these cases the mesentery of the isolated portion is left intact, and the juice can be removed from the loop and its action studied *in vitro*, or food may be placed in the loop, and afterwards removed and examined.

Extracts of the mucous membrane of the intestine, prepared by scraping this off and grinding it with sand and water and then filtering through muslin, usually contain large amounts of ferments. This extract will contain both exoenzymes and endoenzymes.

Succus entericus seems to contain three ferments or ferment-like bodies. One of these has been known for long, and is called *inverting ferment*, because it "inverts" (see p. 285) disaccharides. There are several varieties of inverting ferment depending on the exact nature of the disaccharide on which they act; *e.g.* one acting on maltose (maltase), one on lactose (lactase), and one on cane sugar (invertase). Lactase is present in extracts of the intestinal mucosa only when the food contains lactose. It is therefore absent in the intestine of herbivorous adult animals (guinea pig), but is present for some time after birth, *i.e.* when the animal is living on milk. By feeding milk to adult animals lactose does not reappear in the intestine. Extracts of intestinal mucosa of omnivorous animals (cat and pig) contain lactase throughout life. It cannot be found in the succus entericus, and is therefore an endoenzyme.

Invertase is also stronger in extracts of the intestinal mucosa than in succus entericus.

Maltase is not confined to the intestine, being present in large amount in blood serum, and in most of the organs and tissues of the animal body.

The other two ferments act on proteins. One of them, *erepsin* by name, hydrolyses casein, proteoses and peptones into simple nitrogenous crystalline products. It cannot, however, act on all native proteins. It differs from trypsin in the fact that it can hydrolyse certain polypeptides, such as glycyl-glycin; *d. l.* leucylglycin, etc., on which trypsin

has no action, and that it can carry hydrolysis to a further stage than trypsin. Like trypsin, it acts best in alkaline reaction. It is more plentiful in extracts of intestinal mucous membrane than in succus entericus. It is probably, therefore, an intracellular ferment—endoenzyme—some of it leaking out of the cells into the succus entericus. Since the proteins (*i.e.* peptones) have to pass through these cells during absorption, they will come under the influence of erepsin. Erepsin is not confined to the intestine, but is present in large amount in other parts of the animal body. Next to the intestine, the largest amount has been found (by Vernon) in the kidney, then, in order, the spleen, pancreas, liver, cardiac muscle, brain, skeletal muscle, serum. These endo-erepsins of the tissues probably play an important rôle in the metabolism of proteins.

ADVANCED EXPERIMENT. To Demonstrate the Ereptic Power of Tissues.
—Take 20 grm. minced liver, and 20 grm. mucous membrane of the intestine (scraped off with a scalpel). Grind each in a mortar with fine quartz sand and 20 c.c. of a 0.2 % solution of Na_2CO_3 . Filter the extracts through muslin. Divide each extract into two equal parts, A and B. To A of each extract add 1 c.c. of a 2.5 % solution of Witte's peptone, and to B a similar amount of a 2.5 % solution of egg-white. Remove a few drops of the contents of each of the four test tubes, and apply the Biuret test, noting the results. Place the tubes in the incubator at body temperature, and at the end of an hour again remove a little of the contents of each tube, and apply the Biuret test. It will be found that there is no change in the tube (B) containing egg-white, but that in the tube (A), containing the intestinal extract, the test has become very feeble or disappeared entirely. By longer incubation, the Biuret secretion will also disappear from the tube (A) containing liver.

By thus ascertaining the time required to split up a standard solution of peptone, so that the Biuret test is no longer given, a comparative estimate may be made of the ereptic power of different extracts.

Another ferment-like body in succus entericus is *enterokinase*. Alone, it has no action on any food-stuff, but when mixed with trypsinogen it converts it into trypsin. On a flesh-free diet, the pancreatic juice, as secreted from the duct of Wirsung, contains very little trypsin, and digests coagulated egg-white only slightly even after several hours. If to this inactive pancreatic juice a few drops of succus entericus be added, digestion of the egg-white proceeds actively. Trypsinogen, which is the form in which the proteolytic ferment is secreted on a flesh-free diet, remains inactive until it gets to the intestine, where it is converted into trypsin by the entero-kinase. Enterokinase is not secreted unless it is required, *i.e.* if the intestinal mucosa be mechanically stimulated, a juice will be secreted which contains no entero-kinase.

Bacterial Digestion.—As has been explained above, the conditions

necessary for bacterial growth are very favourable in the intestine. As a result of their growth, bacteria decompose the food-stuffs and lead to the production of products in many cases the same as those of the digestive juices, in other cases of a different nature. In the small intestine the bacteria which are most active are those acting on carbohydrates, whereas in the large intestine these are largely replaced by bacteria acting on protein.

Their action on *proteins* leads to the production of proteoses, peptones, and amino acids, etc. So far their action corresponds to that of trypsin, but they digest farther and produce a multitude of simple degradation products, such as ammonia, fat acids, carbonic acid, etc., as well as a group of substances belonging to the aromatic series.

The aromatic bodies are arranged in two groups. The one contains *phenol* C_6H_5OH and its methyl derivative *kresol* $C_6H_4 \begin{matrix} \text{CH}_3 \\ \text{OH} \end{matrix}$. These are produced from tyrosin, which, it will be remembered, has the formula $C_6H_4 \begin{matrix} \text{OH} \\ \text{CH}_2 \end{matrix} \cdot CH(NH_2) \cdot COOH$. When this changes into kresol and phenol, the amino-propionic acid side-chain loses, first its amino group as ammonia, and then its carboxyl and methyl group are oxidised and given off as carbonic acid and water.

The other group is more complex, and contains *indol* $C_6H_4 \begin{matrix} \text{CH} \\ \text{NH} \end{matrix} \rangle CH$ and its methyl derivative *skatol*

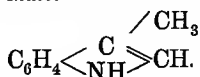

These are derived from tryptophane, a product of the tryptic digestion of certain proteins. Its chemical reactions and constitution are described on p. 395.

Anaërobic bacteria first of all act on the tyrosin and tryptophane, and split off from them the amino (NH_2) groups as NH_3 . After this has been accomplished, aerobic organisms act on the remaining side chains yielding carbon dioxide and water.

Certain of these aromatic bodies—especially skatol—have a strong faeculent odour which they impart to the faeces. Considerable proportions of them are, however, absorbed into the blood and reappear in the urine as indoxyl and skatoxyl in combination with sulphuric acid and alkalis as aromatic sulphates (see p. 435).

These above products also result when proteins undergo putrefaction *in vitro*, but in this latter case other bodies called *ptomaines* are also produced. These are powerful poisons and it is on account of their presence that it is dangerous to eat putrid flesh.

EXPERIMENT X. Preparation and reactions of Indol, Skatol and Phenol. Prepare an artificial digestion mixture with pancreatic extract, or minced pancreas, and allow it to incubate without the addition of an antiseptic, until it has an intense and disagreeable odour. The digest is then acidified with acetic acid and placed in a large flask connected with a Liebig condenser. Distillation is continued as long as the distillate has a marked odour. (Indol distils over much more quickly than skatol). The following tests are then applied to portions of the distillate:—

Indol.—1. **Legal's Test.**—To a few c.c. of the solution in a test tube add a few drops of sodium nitro-prusside solution and then ammonia till alkaline. A deep reddish violet colour results, which changes to blue on acidifying with acetic acid. 2. Add to a few c.c. of the liquid about 2 c.c. of each of the following solutions: (i) Para-dimethyl-amino-benzaldehyde 4 parts, 95 per cent. alcohol 380 parts, hydrochloric acid (conc.) 80 parts. (ii) Potassium persulphate 2 grams in 100 c.c. water; a reddish pink colour results.

Skatol.—Warm some of the solution with an equal volume of strong sulphuric acid. A red colour results.

Phenol.—Boil some of the solution with Millon's reagent. A red colour, but no precipitate results.

The action of bacteria on *carbohydrates* is even more energetic than it is on proteins. They can do all that ptyalin and amylopsin can do, but besides this they can decompose the monosaccharides into simpler bodies such as ethyl alcohol, lactic and butyric acids. They have also the power of digesting cellulose whereby methane (CH_4) is produced as one of the products.

On *fats* they act like steapsin, but here also they can carry the process a stage farther in that they transform the fat acid, which is first of all liberated, into members lower in the fat acid series. They decompose lecithin, and prevent the poisonous action of the liberated cholin by further breaking it up into carbon dioxide, methane and ammonia.

The meconium of the foetus¹ is sterile, but very shortly after birth micro-organisms gain admission to the intestine with the food. The exact varieties of organisms present in the intestine depends mainly on the nature of the food and on the presence of oxygen. The anaërobic bacillus putrificus is the most important proteoclastic organism, its action being supplemented by the aërobic *B. coli* and *B. lactis aërogenes*, *i.e.* the latter organisms act on the products

¹ Meconium is a substance which collects in the intestines during intra-uterine life.

produced by the former. The intestinal bacteria are no doubt very important as digestive agents. Thus, without their aid, cellulose cannot be digested, so that, for herbivora, bacteria are indispensable, at least after they have ceased to live on the mother's milk. Carnivorous animals could probably live without them. It has, for example, been shown that if guinea pig foetuses be excised from the uterus just before full term under antiseptic precautions, and kept in a chamber aspirated with sterile air, and fed on sterile milk, they thrive, and if after some time the intestinal contents be examined, the latter will be found free of bacteria. A repetition of this experiment on chickens (fed on grain) has given quite a different result, for although they took abundance of sterile food, yet they died as soon as if no food had been taken.

The bacteria live in symbiosis with the host in whose intestine they grow—that is to say, both they and their host are benefited by their presence in the intestine.

The Faeces.—These are composed of the following substances:—

1. Substances which have escaped digestion, *e.g.* pieces of vegetables (cellulose, etc.), muscle fibres, elastic tissue, casein, fat, nuclein, haematin, etc.

2. Remains of juices secreted into the intestines, *e.g.* mucin, traces of bile salts and pigments, inorganic salts (alkaline earths), epithelial cells, and cholesterol.

3. Products of digestion, *e.g.* aromatic bodies (indol and skatol), fat acids, methane, ammonia, etc.

4. Micro-organisms. The faeces contain a certain amount of nitrogen, which probably comes from the various secretions rather than from undigested foods (about 1 grm. N. per diem on ordinary diet). The amount of faeces varies very much with the nature of the diet, being about 170 gms. in 24 hours on a mixed diet and 400-500 gms. on a vegetable diet.

CHAPTER XVI.

THE CHEMISTRY OF URINE.

No portion of Biochemistry is of so much practical importance to the medical practitioner as the chemistry of the urine. It is in the urine that the waste products of protein metabolism are chiefly excreted. Urea, uric acid, and creatinin are almost entirely derived from protein, and an estimation of these products in the urine yields valuable

information regarding the breakdown of protein in the body. The main function of the kidneys is to serve as a regulator of the composition of the blood, removing from it any excess of its normal constituents, water, dextrose, sodium chloride, etc., and also injurious waste products, such as urea, uric acid, etc. The capacity of the kidneys for their work can be determined most readily by the examination of the urine. When the kidneys, or other parts of the urinary tract, are diseased, abnormal substances, such as proteins, blood, pus cells, etc., are mixed with the urine and can be detected in it in a more or less changed state, according to the site of the lesion.

In studying the chemistry of the urine, therefore, we must ascertain, firstly, the nature of its various constituents and of their precursors in the blood and tissues; secondly, the total amount of those excretory products which contain the nitrogen of the decomposed proteins; and thirdly, we must look for unusual products, indicating improper composition of the blood or organic disease of the urinary tract.

We must remember that the quantity and the composition of the urine vary considerably within the limits of health, and in order to form reliable conclusions we must collect the total urine for a period of twenty-four hours. Even with a fair sample thus obtained, we must consider the intake and loss of water; copious drinking will increase the quantity and lower the specific gravity of the urine; on the other hand, profuse sweating or diarrhoea will have the opposite effect. The nature of the diet in relation to the reaction of the urine and the quantity of urea must also be considered.

GENERAL CHARACTERS OF URINE.

Quantity.—A healthy man of average weight (65-70 kg.) and height, and living on an ordinary mixed diet, excretes about 1500 c.c. per 24 hours. If we wish to ascertain whether any one of its constituents is being excreted in normal amount, a knowledge of the total daily excretion of urine is indispensable, a mere determination of the percentage in an isolated sample being of *very slight* value. For accurate work (*e.g.* in making observations in metabolism) the method employed is to collect the total urine for the 24 hours in a suitable vessel, and then to remove from this a measured sample for analysis.¹

¹ In doing this, the bladder is emptied at some chosen hour (best in the morning), and this urine thrown away; all urine passed subsequently to this is collected in a sterile flask or bottle containing a few c.c. of chloroform, and at the same hour next day the bladder is again emptied and the urine added to the twenty-four hour specimen. When the observation is being conducted on the lower animals, it is usually necessary to employ the catheter.

The amount of urine is increased by the imbibition of large quantities of liquid and by certain drugs called diuretics; it is diminished by excessive sweating or diarrhoea, and by failure of the heart's action.

Specific Gravity.—This is determined by a special form of hydrometer—a urinometer—graduated so that the zero mark—1000—corresponds to distilled water (Fig. 237).

EXPERIMENT I. Fill a urine testing glass with urine cooled to room temperature, place the urinometer in it, and read off the graduation which is on a level with the surface of the urine. Be careful that the urinometer does not stick to the sides of the vessel.

The average density varies between 1015 and 1025, but a highly concentrated urine, *e.g.* after severe sweating, may reach 1035, or a very dilute one, *e.g.* after huge potations, 1002, and still be healthy. A specific gravity over 1030, however, usually indicates the presence of sugar or the existence of high fever, and one much below 1010 should raise suspicions of renal trouble.

Reaction.—Healthy urine usually reacts acid to litmus. This acidity is due to sodium dihydrogen phosphate, NaH_2PO_4 , not to free acid.

EXPERIMENT II. Test the reaction of urine with blue litmus paper and congo red paper. The litmus is turned red, but the congo red is not altered, as it is not affected by the acid salts of any but the strongest acids (see Digestion, p. 376).

The alkaline phosphate, Na_2HPO_4 , may be present in urine. It is detected by the addition of calcium chloride to the urine, when a precipitate of calcium phosphate forms if the alkaline phosphate is present, but not if the acid phosphate alone is present. The amount of alkaline phosphate may be sufficient to cause the urine to have an amphoteric reaction, turning red litmus blue and blue litmus red, or even to have a definite alkaline reaction. This is often the case during the stage of digestion, when hydrochloric acid is being poured into the stomach, as the removal of hydrochloric acid from the blood leaves an excess of bases.

Besides the alkaline phosphate, alkaline bicarbonates may be present in urine, causing an effervescence on the addition of acid. This is the case when salts of oxidisable acids (*e.g.* citric, tartaric, etc.) are being

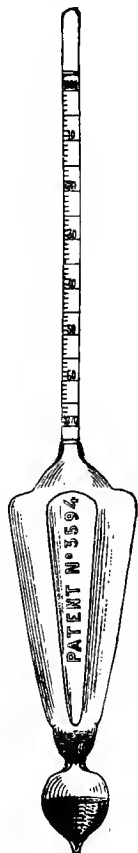

FIG. 237.—The urinometer.

taken by the mouth, and when the diet is an exclusively vegetable one. Lastly, an alkaline reaction may be due to ammonia, which is produced by microbial hydrolysis of urea (see Urea, p. 417). For this reason stale urine always reacts alkaline. If the alkaline reaction of freshly passed urine is due to ammonia, decomposition must be taking place in the bladder.

Colour.—The straw colour of healthy urine is due to *Urochrome*, the origin of which is uncertain. Another pigment, *Urobilin*, is normally present in traces in the urine. In fever, and when there is liver disease or rapid destruction of haemoglobin, the amount of urobilin is often much increased, imparting a reddish tint to the urine. Urobilin is identical with stercobilin, the pigment of faeces, which is formed from bilirubin in the intestine by bacterial action, so that its presence in urine is presumably due to absorption from the intestine. Urobilin can also exist in the urine as a colourless precursor, or *chromogen*, which yields the pigment, when the urine is acidified with sulphuric acid and allowed to stand.

EXPERIMENT III. Examine an acid solution of urobilin or stercobilin with the spectroscope. A diffuse absorption band is seen between the green and the violet of the spectrum.

A third pigment is *uroerythrin*, the colouring matter of pink urate deposits. It appears to be related to skatoxyl sulphuric acid. *Haematoporphyrin* (see Haemoglobin, p. 350) may also occur.

Indican, or indoxylsulphuric acid (see Ethereal Sulphates, p. 437), is the cause of the blue tint sometimes acquired by urine on standing, as it is oxidised to indigo blue. Normally a small quantity is present. This is increased when there is excessive putrefaction in the small intestine, or in an abscess.

EXPERIMENT IV. Test urine for indican. Mix about 5 c.c. of urine in a test tube with an equal volume of strong hydrochloric acid containing 0.4 per cent. ferric chloride. Add about 3 c.c. of chloroform and shake the tube. The chloroform on settling will be tinged with blue (indigo) if the urine contains indican.

The Nitrogenous Constituents.—Over 90 per cent. of the nitrogen in combination excreted by the body is present in the urine, the remainder occurring in the faeces (about 1 gramme per diem), and as urea in the sweat. A determination of the *total nitrogen* of the urine is, therefore, of great importance. The method employed is that of *Kjeldahl*.

EXPERIMENT V. Measure 5 c.c. of urine with a pipette into a Jena flask. (This flask should be of at least 400 c.c. capacity. It saves time and chance of error to use the flask of 750-1000 c.c. capacity,

from which ultimately distillation of the ammonia is to be carried out.) Add approximately 0.5 gm. copper sulphate and 2.0 gm. potassium sulphate, and then 10 c.c. of pure concentrated sulphuric acid. Put the flask on a rack (Fig. 238), so constructed that the neck of the flask lies in a slanting position with the belly of the flask, fitting into the depression made to receive it in the asbestos plate or sand-bath. Start the heating with a low flame. After 10-15 minutes, if there is no excessive foaming, turn up the flame and heat the mixture strongly

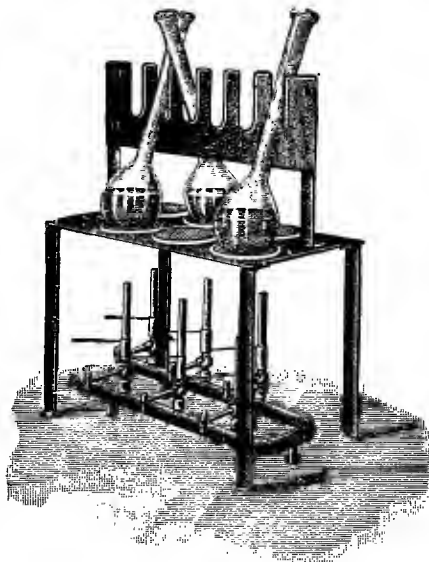

FIG. 238.—Apparatus for determination of total nitrogen.

until it is a clear greenish blue. Now shake the flask with a rotary motion so as to wash down from the wall any carbonaceous particles which may be sticking to it. Continue heating until the liquid is perfectly clear again. The stage of incineration is now complete. (*1st stage.*)

The chemical reaction which takes place is that the sulphuric acid decomposes the organic matter, the carbon being oxidised to carbon dioxide, and the nitrogen changed into ammonia, which immediately on its formation combines with the excess of sulphuric acid present to form ammonium hydrogen sulphate. The first effect of adding the acid is to produce charring (*i.e.* the mixture becomes black), and the reaction is complete whenever all this liberated carbon has been oxidised.

The sulphates of copper and potassium accelerate the process very greatly, the former by acting as a carrier of oxygen, the latter by raising the boiling point of the mixture.

Distillation (2nd stage).—When the acid mixture has cooled, add 100 c.c. of distilled water (free from ammonia if obtainable), and mix. If the incineration was performed in a small flask, it will be necessary to transfer its contents to a large Jena flask for the distillation,¹ and rinse with portions of about 100 c.c. water, until the distilling flask is nearly half full. If the mixture is already in the distilling flask the requisite amount of water is added. Add a little powdered pumice or mica to prevent bumping. Then, holding the flask in a slanting position, pour strong caustic soda (40 to 50 per cent.) solution, enough to render the liquid alkaline, down the neck and wall of the flask so as to form a bottom layer of alkali. By this means any ammonia set free by the alkali will be caught by the overlying acid mixture. The amount of alkali required to render the mixture alkaline must be previously determined; 40 c.c. is usually an excess.

Attach the flask to the distilling apparatus (see Fig. 239). Place 50 c.c. $\frac{n}{10}$ sulphuric acid, about an equal volume of distilled water and a few drops of methyl orange solution, or other suitable indicator, in the receiving flask. Adjust the delivery tube of the apparatus so that it just dips below the surface of the liquid in the receiver. Mix the contents of the distilling flask. (If enough alkali has been added a blue colour will develop owing to the liberation of cuprous hydroxide.) Light the burner, and continue the distillation for at least 15 minutes, taking care to prevent the sucking back of the contents of the receiver into the distilling flask.²

Lower the receiver so that the delivery tube is above the liquid, and continue the distillation for a few minutes so as to wash out the inside of the tube. Finally wash the outside of the tube with a jet of water from the wash bottle, so as to remove adhering acid, and remove the receiver for the titration. Should the contents of the receiver become neutralised during the distillation, as shown by the indicator changing colour, a further measured quantity of $\frac{n}{10}$ acid must be added.³

¹ 750-1000 c.c. capacity.

² A vertical condenser, replacing the descending portion of the delivery tube, reduces the risk of sucking back and prevents the heating of the liquid in the receiver, and is, therefore, desirable in accurate work.

³ It is often necessary to continue the distillation for considerably more than 15 minutes. When it is doubtful whether all of the ammonia has distilled over in this time, distillation should be continued into a second flask containing a few c.c. decinormal acid and distilled water.

The chemical reaction involved in this stage of the method is the liberation of ammonia from the ammonium hydrogen sulphate (produced in the incineration stage) by the excess of alkali added to the contents of the distilling flask. This ammonia is completely carried over into the sulphuric acid of the receiver during the distillation, and thus quantitatively neutralises some of the acid.

Titration (3rd stage).—Cool the receiver under the tap. Run in $\frac{n}{10}$ caustic soda carefully from a burette, until its contents are neutral,

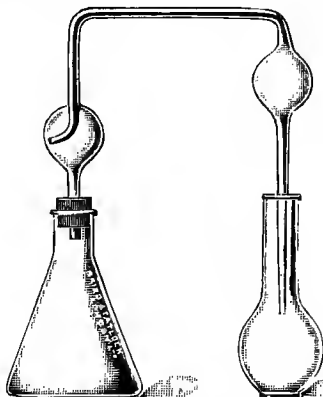

FIG. 239.—Apparatus for determination of total nitrogen.

as shown by the change in colour of the indicator employed. Subtract the volume in c.c. of $\frac{n}{10}$ soda required for neutralisation from the volume of $\frac{n}{10}$ acid originally added to the receiver. The remainder represents the volume in c.c. of $\frac{n}{10}$ acid neutralised by ammonia during the distillation. Let this remainder be n c.c. Then, as the ammonia distilled quantitatively represents the total nitrogen present in the 5 c.c. of urine taken, this 5 c.c. of urine contains $n \times 0.0014$ gm. nitrogen, and, therefore 100 c.c. of the urine contain $\frac{n \times 0.0014 \times 100}{5}$ gm. nitrogen.

To take an example, suppose that 50 c.c. $\frac{n}{10}$ acid were placed in the receiver, and that after the distillation 19.4 c.c. $\frac{n}{10}$ alkali were required for neutralisation. Then 5 c.c. urine contain

$$(50 - 19.4) \times 0.0014 \text{ gm.} = 0.0428 \text{ gm. nitrogen.}$$

Therefore 100 c.c. urine contain 0.856 gm. nitrogen.

EXPERIMENT VI. Determine by the above method the amount of nitrogen contained in an acid solution of ammonium sulphate.¹

Measure out 5 c.c. of the solution with a pipette, place it in the distilling flask A, dilute to 200 c.c. with water. Now measure accurately 20 c.c. $\frac{n}{10}$ acid and place in receiving flask B, adjust distilling tube C, add excess of caustic soda, and distil as above.

The total amount of nitrogen excreted by the urine per diem in the case of a man living on an ordinary diet varies between 15 grammes and 20 grammes, and, if the total amount of nitrogen taken in the food be ascertained, it will be found to nearly correspond to this. By special precautions it can be made to accurately correspond when the person is said to be in *nitrogenous equilibrium*.² The nitrogenous constituents of the urine, which collectively make up this total amount of nitrogen, vary in their relative amounts according to the amount of nitrogen which the diet contains. This fact has been clearly shown by Folin, who, for the purpose of demonstrating it, first of all elaborated rapid and accurate methods for estimating these nitrogenous bodies. By the use of the older methods, the chemical estimations were too laborious and too complicated to permit of a sufficient number of analyses being made in daily urine. These methods will be described in their proper places, but in the meanwhile it may be well to briefly consider the main results which have been obtained.

The chief nitrogenous bodies which occur in the urine are urea ($\text{CO}(\text{NH}_2)_2$), uric acid ($\text{C}_5\text{H}_4\text{N}_4\text{O}_3$), ammonia (NH_3) and creatinin ($\text{C}_4\text{H}_7\text{N}_3\text{O}$). There are several other nitrogenous substances which are present only in small amounts and are estimated together as undetermined nitrogen. In the following table, the first column gives the relative amounts of these bodies in the urine when a diet rich in nitrogen was taken, and the second column the corresponding data when the diet contained very little nitrogen. The diet rich in nitrogen was made up of whole milk (500 c.c.), cream (300 c.c.), eggs (450 grm.), Horlick's malted milk (200 grm.), sugar (20 grm.), salt (6 grm.), and water sufficient to make up to 2000 c.c. Besides this, 900 c.c. water were allowed. The diet contained about 19 grm. of nitrogen. The diet poor in nitrogen consisted of 400 grm. arrowroot starch made into a paste with 1500 c.c. water, then partly digested for

¹ A suitable solution for the purpose is made by dissolving 1.32 grammes of ammonium sulphate crystals in 100 c.c. of 1 per cent. sulphuric acid; 5 c.c. of this solution contains 0.014 gramme N.

² Allowance must also be made for the nitrogen in the faeces.

half-an-hour with diastase (2 grm.) and taken with 300 c.c. cream. It contained only about 1 grm. of nitrogen and could be taken without great discomfort to the person for several days. It might have been better had it contained twice as much cream, for then the breakdown of tissue protein which occurred would have been diminished.

	Nitrogen—rich diet. 1170 c.c.	Nitrogen—poor diet. 385 c.c.
Volume of urine	1170 c.c.	385 c.c.
Total nitrogen	16·8 grm.	3·60 grm.
Urea-nitrogen	14·7 grm. = 87·5 % of total N.	2·20 grm. = 61·7 % of total N.
Ammonia nitrogen	0·49 grm. = 3·0 %	0·42 grm. = 11·3 %
Uric acid nitrogen	0·18 grm. = 1·1 %	0·09 grm. = 2·5 %
Creatinin nitrogen	0·58 grm. = 3·6 %	0·60 grm. = 17·2 %
Undetermined nitrogen	0·85 grm. = 4·9 %	0·27 grm. = 7·3 %

When the intake of nitrogen by the diet is much reduced, the percentage of the total nitrogen excreted as urea markedly falls, whilst that of the other nitrogenous bodies rises. It will further be noted, however, that the *absolute* amounts of all these bodies falls, except in the case of creatinin, which remains unchanged.

The total sulphate excretion is made up of inorganic sulphates, ethereal sulphates, and neutral sulphur, and the relative amounts of these excreted on a rich and a poor diet show striking resemblances to the nitrogenous bodies, as will be discussed later.

CHAPTER XVII.

UREA.

UREA is the diamide of carbonic acid.

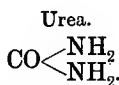
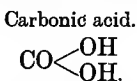

In common with other acid amides, urea has weak basic properties, forming unstable salts with nitric and oxalic acids.

EXPERIMENT I. To some urine, which has been evaporated to small bulk on a water-bath, add some pure, colourless (not fuming)

nitric acid, and cool the mixture by holding the test tube under the tap. Crystals of urea nitrate separate out. Examine these with the microscope, and note that they are either rhombic tables or six-sided plates, which overlap each other like the tiles of a roof (see Fig. 240).

EXPERIMENT II. Repeat experiment with a saturated alcoholic solution of oxalic acid, and note that the crystals are not unlike those of the nitrate, being elongated plates with bevelled pointed ends (Fig. 241).

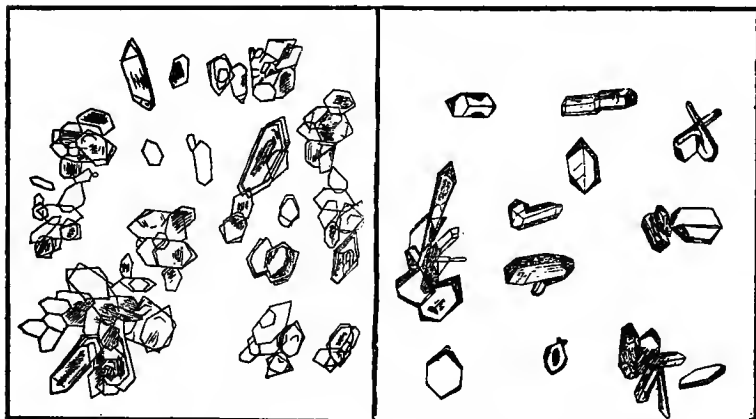
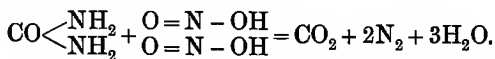

FIG. 240.—Urea nitrate.

FIG. 241.—Urea oxalate.

Urea is decomposed by nitrous acid— HNO_2 —carbonic acid gas and nitrogen being evolved :



EXPERIMENT III. Add some fuming nitric acid (*i.e.* containing nitrous acid) to urine, and note the effervescence which results. That one of the gases evolved is carbon dioxide can be proved by holding the mouth of the test tube over another one containing lime water or baryta water, when, on shaking, the latter will turn milky.

A very similar reaction is obtained by adding a hypobromite or hypochlorite to urine.

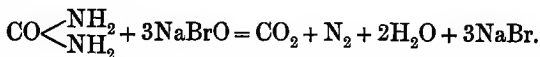

The carbon dioxide formed combines with excess of caustic soda

present in the hypobromite. This reaction is employed in the quantitative estimation of urea (see below, p. 419).

There are several reactions which are peculiarly interesting, since they demonstrate the chemical relationships of urea to its probable precursors in the tissues (see below). Thus, if urea be hydrolysed (*i.e.* be caused to take up water) it forms ammonium carbonate:

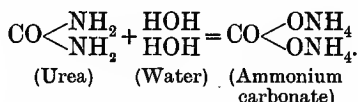

This process occurs in urine which has stood for some time, the hydrolysis being effected by several kinds of microbes. It may also be produced by boiling urea with strong acids or alkalies; in both cases the ammonium carbonate is further decomposed, liberating, in the case of alkalies, ammonia gas (the carbon dioxide being absorbed by the alkali present), and in the case of acids, carbon dioxide gas (the ammonia being absorbed by the acid present).

EXPERIMENT IV. Prepare a solution of pure urea, and divide it into two portions, A and B. To A add about 10 drops of sulphuric acid and boil, meanwhile collecting the vapour which comes off in a second test tube containing lime or baryta water. By this becoming milky, the presence of carbon dioxide gas is demonstrated. To B add about 5 drops saturated caustic potash and boil. Ammonia gas is evolved, so that a moistened strip of red litmus paper is turned blue if held in the fumes, which smell strongly of ammonia.

A substance intermediate between urea and ammonium carbonate, and having therefore the formula $\text{CO} \begin{array}{l} \text{<ONH}_4 \\ \text{<NH}_2 \end{array}$, can be formed by allowing dry carbon dioxide gas to act on dry ammonia. This is called ammonium carbamate. If heated to 135° C. it splits up into urea and water. A certain amount of ammonium carbamate is always present in watery solutions of ammonium carbonate.

Dry heat splits urea into ammonia gas and a body called Biuret. By further heating, Biuret changes into cyanuric acid (HCNO_3), which is isomeric with cyanic acid, HCNO .

EXPERIMENT V. Heat some urea crystals in a dry test tube. Note that they melt and give off ammonia. Continue heating for a few minutes, then cool the test tube and dissolve the residue in water, and to this solution apply the Biuret test. A rose pink colour results (see Peptone, p. 302).

Conversely, we can change cyanic acid into urea by evaporating an aqueous solution of ammonium cyanate (NH_4CNO) to dryness. This

salt has the same empirical formula as urea, but its structural formula is different :

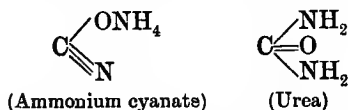

It was by this means that Wöhler first showed that organic bodies of animal origin could be formed from inorganic substances.

PREPARATION OF UREA.

1. From Urine.—To about 400 c.c. urine add barium mixture (1 vol. saturated barium nitrate solution mixed with 2 vol. baryta water) until there is no further precipitate of sulphates and phosphates. Filter and evaporate the filtrate—at first over a free flame, afterwards on a water-bath—to a thin syrup. Now mix this syrup with about 100 c.c. methylated spirit, and, after allowing the mixture to stand for about half an hour so that the precipitate of inorganic salts may settle, filter the alcoholic extract into an evaporating dish and evaporate it nearly to dryness on a water-bath. Allow the residue to cool, and then add to it about double its volume of concentrated pure nitric acid, meanwhile placing the basin in a dish of cold water, and stirring the contents with a glass rod so as to accelerate the formation of the urea nitrate. After about half an hour the crystals of urea nitrate are filtered off by means of a suction filter, sucked as dry as possible, and then placed between several thicknesses of filter paper, between which they are pressed so as to dry them. In order to convert the nitrate into urea, the crystals are placed in an evaporating dish and dissolved in as little water as possible; the basin is then placed on a heated water-bath, and powdered barium carbonate added with a penknife in small quantities until the fluid reacts neutral. By this treatment the urea nitrate is decomposed, the nitric acid combining with barium to form barium nitrate, and the urea being thereby liberated. The mixture is now filtered, the filtrate evaporated to dryness and the urea taken up from the residue by extracting with absolute alcohol, which does not dissolve the barium nitrate. The alcoholic solution of urea is now evaporated to dryness, when a mass of urea crystals is obtained.

The above process may be considerably curtailed by omitting the preliminary precipitation of phosphates, etc., with barium mixture, the evaporated urine being simply mixed in a test tube with nitric acid, which is kept cool by immersing it in a beaker of water. The crystals of urea nitrate are then filtered off, dried between filter paper and treated with barium carbonate as above described.¹

2. Separation of Urea from Blood, Serous Fluids or Watery Extracts of Tissues.—About 100 c.c. of the fluid are mixed with four times its volume of methylated spirit, vigorously shaken and allowed to stand over night. By this treatment the proteins are coagulated, whereas the spirit dissolves the urea. The coagulum is now filtered off, washed with spirit, and the washings are combined with the filtrate, the whole being then evaporated to dryness on a water-bath. The residue is extracted with absolute alcohol, the extract filtered, again evaporated to dryness and re-extracted with absolute alcohol, this process being

¹ By adding powdered animal charcoal after barium carbonate, and boiling and filtering, the final product will be rendered colourless.

repeated until the evaporated residue is entirely dissolved in the alcohol. The purified residue is now cooled by placing the dish containing it on ice, and is mixed with one or two drops of pure nitric acid, the mixture being allowed to stand on ice till next day, when it is examined for crystals of urea nitrate.

The alcoholic extracts usually contain a considerable amount of fatty acid which may mask the separation of urea nitrate. To remove this, the first alcoholic extract should be mixed with a few drops of a solution of basic lead acetate till no more precipitate is produced, after which a few drops of a solution of ammonium carbonate are added to cause the suspended precipitate of lead soaps to settle down. The solution is then filtered, and the lead removed from the filtrate by passing a stream of H_2S gas through it.

For quantitatively estimating urea the following methods may be employed:—

I. By decomposing urea with sodium hypobromite in the presence of free caustic alkali. The alkali absorbs the liberated carbonic acid and the nitrogen is collected in a graduated tube. From the amount of nitrogen evolved the urea can be calculated by remembering that 0.1 gm. urea contained in urine yields 37.1 c.c. moist nitrogen at $15^\circ C.$ and 760 mm. pressure. 0.1 gm. of pure urea should theoretically liberate 39.76 c.c. nitrogen under the above conditions, but only about 92 per cent. of the urea nitrogen is liberated by the hypobromite. This deficit is, in urine, however, partly compensated by a certain amount of nitrogen being simultaneously split off from the other nitrogenous bodies present. The method is therefore only approximate. There are various forms of apparatus used for collecting the liberated nitrogen. That of Dupré (Fig. 242) consists of an inverted burette (*a*) placed in a cylinder of water, and to the neck of which is connected a T-piece (*f*). With the side tube of this the generating bottle is connected by india-rubber tubing, and the other tube is closed with a piece of tubing and a clip. To make the estimation, 25 c.c. of the alkaline solution of sodium hypobromite are placed in the generating bottle (*o*) and 5 c.c. urine in a small tube, which is then carefully placed in the generating bottle without allowing the two fluids to mix. The cork of the generating bottle is then inserted, and the meniscus of the water both inside and outside the burette brought to the same level at the zero mark, the clip on the T-piece being open meanwhile, and water being added to, or removed from, the outer vessel if necessary. The clip is now applied, and the burette raised to ascertain that no leakage exists. The two menisci are then readjusted, and the contents in the generating bottle mixed. The evolved N displaces the water in the burette. After the reaction is complete, the generating flask is immersed in a basin of water, so as to bring the temperature of

the gas contained in it to the same as that of the gas in the burette. After waiting two minutes the two menisci are again brought to the same level, and the number of c.c. of N read off. Another form of apparatus is that of Gerrard (Fig. 243).

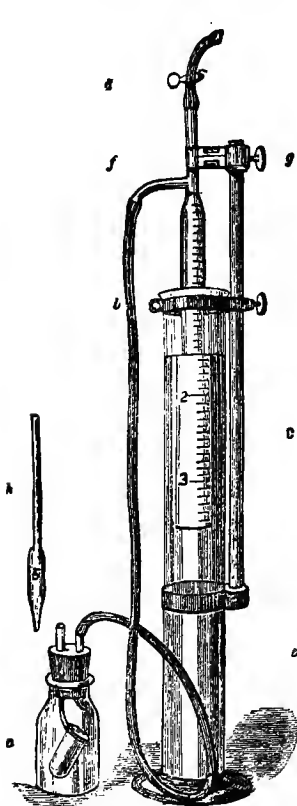

FIG. 242.—Dupré's urea apparatus.

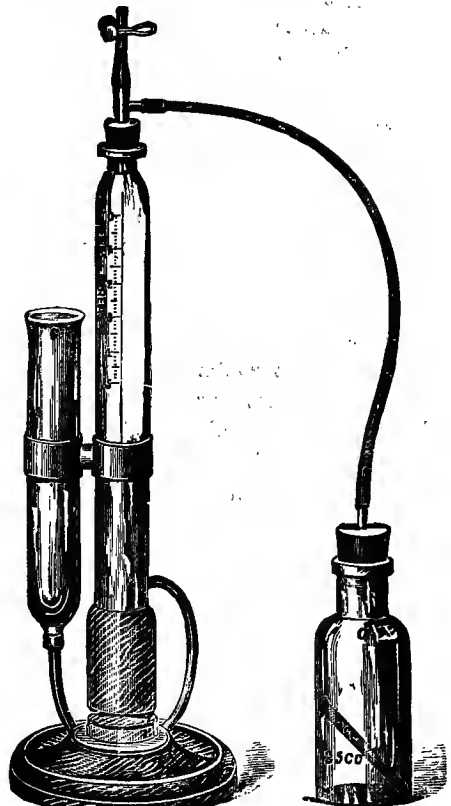

FIG. 243.—Gerrard's urea apparatus.

For rapid clinical purposes quite satisfactory results may be obtained by using the Doremus ureometer (Fig. 240), with side tube for the urine. In using this 2 c.c. of urine are placed in the small side tube and the main tube is filled with the hypobromite solution. By turning the stopcock the urine is then allowed to run very slowly into the hypobromite, when the nitrogen rises to and collects at the top of the tube. When all effervescence has ceased the apparatus is allowed to stand until it is cooled to room temperature, when the graduation at which the meniscus stands is noted. This

graduation corresponds to grammes of urea in the quantity of urine used.

II. Mörner-Folin Method.—*Principle.*—By the addition of certain reagents to a measured quantity of urine, the greater proportion of the nitrogenous bodies, except urea and ammonia, are precipitated. The precipitate is removed by filtration, and, after expelling the ammonia by heat, the nitrogen of the filtrate is determined. This, multiplied by 2.143, gives the amount of urea present.

Solutions necessary.—

1. Powdered barium hydroxide (baryta).
2. A mixture of 1 vol. ether and 2 vol. absolute alcohol.
3. Apparatus, etc., for Kjeldahl's nitrogen determination.

Determination.—5 c.c. urine are shaken in a small stoppered flask with 1.5 gm. barium hydroxide until no more will dissolve: 100 c.c. alcohol-ether mixture are then added, whereon a copious precipitate falls down. The flask is corked and left standing over night. The contents are then filtered through a small filter paper (10 cm. in diameter), the filtrate being collected in a Kjeldahl combustion flask of 500 c.c. capacity. When all the solution has passed through, the precipitate is washed at least three times with alcohol-ether mixture, and then the flask is connected with a suction pump and placed on the water-bath heated to 55° C.¹ When the liquid has been reduced to a few c.c., 25 c.c. water and a pinch of magnesium oxide are added to the contents and the evaporation continued so as to drive off the last traces of ammonia from the solution. When the volume of fluid in the flask has reached about 10 c.c. the urea is determined by Folin's method.

Folin's Method.—Unless reducing substances such as sugar are present this method is usually applied directly to the urine without a preliminary treatment by the Mörner and Folin method.

The principle of this method depends on the fact that urea becomes completely hydrolysed into carbon dioxide and ammonia, when solutions of it are heated for about an hour to a temperature of 150°–160° C. The hydrolysis must be performed in acid reaction so that no ammonia can escape. The above temperature may be obtained, either by heating under pressure (in an autoclave) or, as recommended by Folin, by heating the urine with magnesium chloride which, after the excess of water has evaporated, gives a solution boiling at 160° C.

EXPERIMENT.—Place 5 c.c. urine, 5 c.c. HCl (con.) and 20 gm. magnesium chloride in a 200 c.c. Jena flask. Connect the neck of the flask with a glass trap or a wide tube, and heat fairly strongly so as to drive off the water from the contents of the flask. The trap prevents too much HCl from escaping. When all the water has been boiled off (10–15 minutes) the contents of the flask will change in their manner of boiling (they will behave as warm water does when H₂SO₄ (con.) is dropped into it). Now lower the flame and connect the

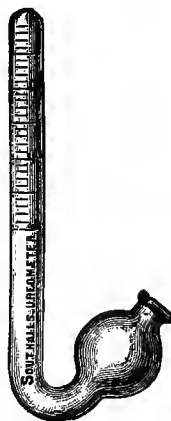

FIG. 244.—Ureometer.

¹To employ the suction pump in this way to accelerate evaporation at low temperature the flask is closed by a doubly-bored cork; through one hole the pump is connected, through the other passes a tube ending below the surface of liquid in the flask in a fine capillary point,

flask with a reflux condenser, keeping its contents just boiling for $1\frac{1}{2}$ hours. After this time, and without permitting the flask to become cold, add distilled water cautiously and transfer the contents to a Kjeldahl distilling flask; bring the volume of fluid up to 600 c.c. and allow 10 c.c. of 40 per cent. NaOH solution to run down the side of the flask so as to form a layer under the watery solution. Add some powdered pumice and distil the contents into a measured quantity of $\frac{n}{10}$ H_2SO_4 as described in connection with Kjeldahl's method. The distillation requires much longer than in Kjeldahl's process ($1\frac{1}{2}$ hours).

From the number of c.c. of $\frac{n}{10}$ NH_3 found must be deducted:—

(1) The c.c. $\frac{n}{10}$ NH_3 present as such in the 5 c.c. of urine used (determined by Folin's or Shaffer's method, p. 433).

(2) The c.c. $\frac{n}{10}$ NH_3 present in the reagents for MgCl_2 always contains traces of NH_3 .

CHAPTER XVIII.

URIC ACID AND OTHER PURINE BODIES.

It will be remembered, from the description of the chemical structure of nuclein (p. 310), that there exist among its decomposition products several bodies belonging to the so-called purine group of chemical substances. Uric acid is also a member of this group. The group receives its name because all the members of it contain, as their nucleus of construction, a body called purine, which exists as a double ring of carbon and nitrogen atoms. The various members of the group differ from one another according to the nature and position of the atoms or groups of atoms which are tacked on to this purine ring. In order to make the relationships clear the structural formulae of the various members should be studied side by side, thus:—

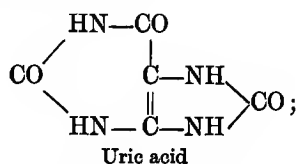
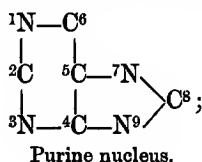

(2, 6, 8, trioxypurine).

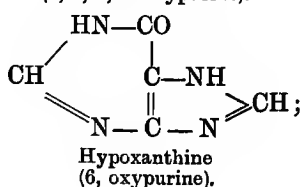
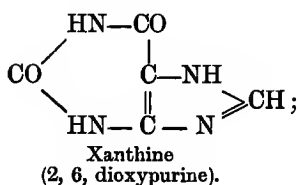

synthesised in the liver from oxidation products of lactic acid. Whether such a synthesis takes place also in mammals is at present unknown.

On oxidation with potassium permanganate uric acid yields *allantoin*, which is present in the urine of the dog and cat, and occasionally in that of man. The formula for allantoin is:—

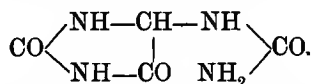

On oxidation with nitric acid, uric acid yields *alloxan*, carbon dioxide, and nitrogen. An intermediate oxidation product, *alloxantin*, is formed at the same time, which with ammonia forms a red dye, *murexide*. This reaction is used as a test for uric acid. Alloxan is the ureide of mesoxalic acid:—

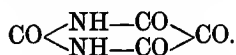

Further oxidation yields the ureide of oxalic acid.

Ordinarily uric acid behaves as a monobasic acid, being soluble in alkalis (caustic soda, ammonia, and boiling solution of sodium carbonate) with the formation of the corresponding salts, which are more soluble in water than the free acid. The dibasic salts can, however, be obtained by the use of excess of concentrated alkali, so that it is the custom to call uric acid a dibasic acid and its ordinary salts acid salts, although their solutions are alkaline, not acid. Strictly speaking, uric acid is a tetrabasic acid, as all four hydrogen atoms in the molecule have latent acid properties.

Uric acid is the principal nitrogenous excretive of birds and reptiles. Together with other purine bodies it is always present in the urine of man, having a twofold origin, exogenous and endogenous. The exogenous purines come from purine bodies in the food (nucleo-proteins in cellular structures, xanthine and hypoxanthine in meat, caffeine, etc.). The endogenous output of purines is fairly constant for a given individual under ordinary conditions, and is to be traced, partly at any rate, to the breakdown of nucleo-proteins in the body. Burian and Schur found the daily purine excretion of a normal individual on an ordinary diet to be about 1 gm. On a purine free diet this was reduced to 6.0 gm., and was practically independent of the amount of nitrogen in the food. Violent muscular exercise and pyrexia both increase the output of purine bases and uric acid on a purine free diet. This effect is presumably connected with the xanthine and hypoxanthine of muscle (see p. 354).

PREPARATION AND REACTIONS OF URIC ACID.

EXPERIMENT I. To 100 c.c. urine add 5 c.c. HCl (conc.), and allow the mixture to stand overnight. It will then be found that a dark-brown sediment, like cayenne pepper, has settled down, and probably also that a brown scum has formed on the surface. Filter and examine the sediment under the microscope. It consists of large dark-brown clumps of crystals, whetstone or barrel-shaped (Fig. 245). These are crystals of uric acid admixed with pigment. They can be purified by solution in 5 per cent. KOH and reprecipitation by HCl. Preserve the crystals for further use.

EXPERIMENT II. Pure crystals can be obtained from the solid urine of a snake or bird. This urine, which consists of sodium urate, is dissolved in caustic potash and acidified with HCl. Pure uric acid separates out.

From these two experiments we learn that uric acid exists in urine as a salt. If this salt be decomposed by a mineral acid the liberated uric acid, being very insoluble, is precipitated.

The following are the most important *reactions of uric acid*.

EXPERIMENT III. **The Murexide Test.**—Place some uric acid or bird's urine in a capsule, add a few drops of dilute nitric acid, evaporate *slowly* to dryness on a water-bath. A yellow residue is obtained. Add a drop of ammonia, a crimson colour results, which is changed to purple by adding caustic soda. If overheated, the residue will turn crimson without the addition of ammonia.

EXPERIMENT IV. Uric acid has the power of reducing metallic oxides in alkaline solution. This may be demonstrated by the following tests. Some uric acid is dissolved in weak sodium carbonate solution, which is then poured on to a piece of filter paper moistened with a solution of AgNO_3 . A black stain of reduced silver results. This is called Schiff's reaction. In the presence of neutral salts, and more especially of magnesium mixture (MgCl_2 , NH_4Cl , NH_3), the uric acid and other purine bodies unite with the silver to form a double salt. This salt separates out as a gelatinous precipitate, and is employed for quantitatively estimating the purine bodies (Salkowski's method). Uric acid can also exercise its reducing powers on cupric salts in alkaline solution. By applying Trommer's test, or one of its modifications, to an alkaline solution of uric acid, it will be noticed that reduction ensues. The reduction precipitate is, however, of a dull brown colour instead of being yellowish red, as it usually is. This is because a certain amount of the cuprous oxide unites with some of the uric acid to form a brown compound.

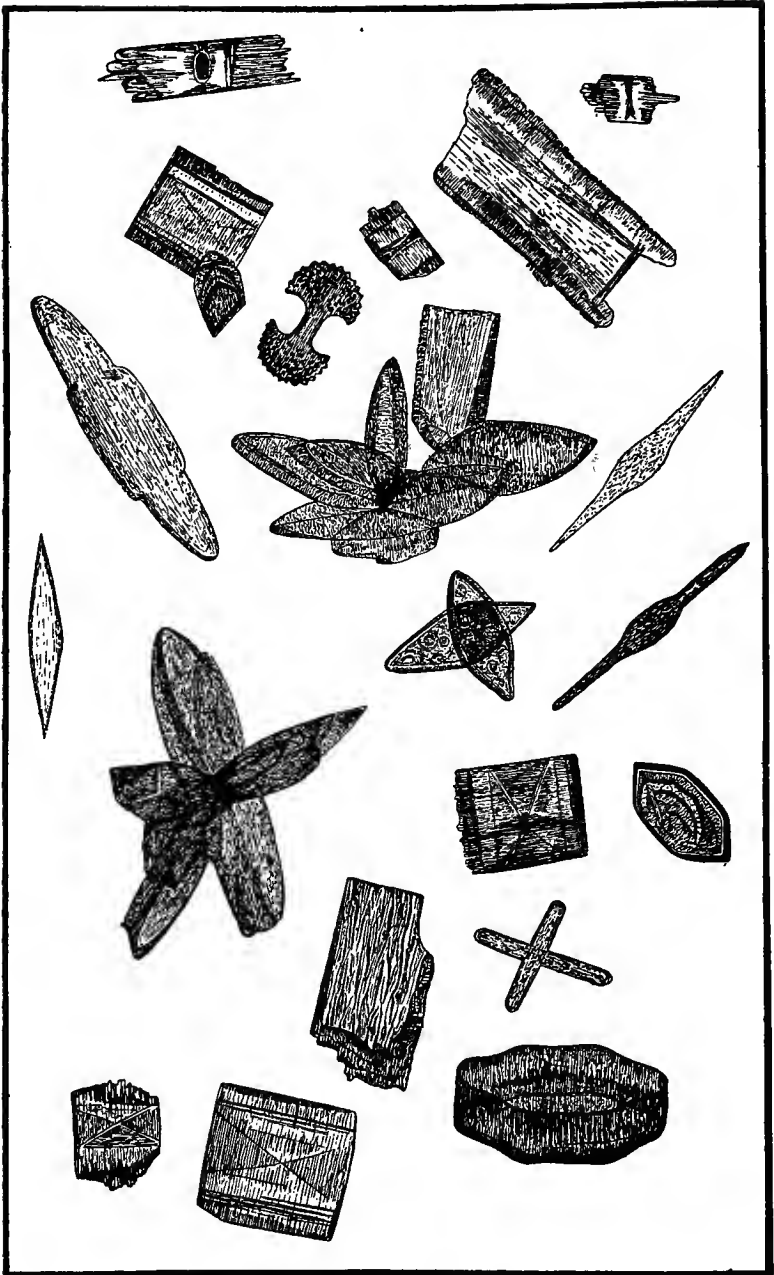

FIG. 245.—Crystals of uric acid.

EXPERIMENT V. Tests for Uric Acid in Urine.—Apply *Schiff's* test to urine. The result is positive, but does not necessarily show the presence of uric acid, as other reducing bodies are present in the urine. The *murexide* test cannot be applied directly to urine, as urine yields a red pigment on heating with nitric acid. In order to apply this test take about 100 c.c. of urine, add ammonia until it is alkaline, and saturate with ammonium chloride. A precipitate of ammonium urate forms. This is filtered off, dissolved in a few c.c. of water, and employed for the murexide test.

ESTIMATION OF URIC ACID.

The most rapid and accurate method is that of Hopkins as modified by Folin.

In this method the mucoid substances and some of the phosphates of urine are first of all precipitated by a strong solution of ammonium sulphate containing uranium acetate and acetic acid, and the filtrate is then rendered alkaline with ammonia; on standing ammonium urate separates out. This is collected on a filter, washed, and suspended in water and titrated with $n/20$ potassium permanganate.

The method is carried out as follows:—

To 300 c.c. urine in a flask 75 c.c. of the uranium ammonium sulphate reagent is added (500g. ammon. sulph., 5gr. uranium acetate, 60 c.c. 10 per cent. acetic acid, 650 c.c. water), and in five minutes the solution is filtered through a dry thick filter paper into a dry 250 c.c. measuring cylinder, or into a dry beaker. Two portions of the filtrate of 125 c.c. each are transferred to beakers and 5 c.c. concentrated ammonia added to each. The beakers are then set aside for twenty-four hours, at the end of which time the precipitate of ammonium urate will be found on the bottom of the beaker. The clear supernatant fluid is carefully poured through a hardened filter, after which the sediment is shaken with a 10 per cent. solution of ammonium sulphate and carefully collected on the same filter and washed once or twice with the 10 per cent. ammonium sulphate solution. It is unnecessary to transfer every trace of precipitate to the filter, and the washing with ammonium sulphate solution does not require to be prolonged. The filter is then opened up and the precipitate washed into the beaker in which the original precipitation was made by means of a spray of distilled water from a wash bottle. As a result of this process about 100 c.c. of fluid should have collected in the beaker. Then 15 c.c. H_2SO_4 (conc.) is added to the fluid, and while still hot from the mixing of acid and water, it is titrated with $n/20$ potassium permanganate until a faint pink colour remains for five seconds after mixing. The reading obtained, multiplied by 0.00375, gives the grammes of uric acid in 100 c.c. of urine.¹

Estimation of the Total Purine Bodies. Modified Camerer's Method.

—*Principle.*—Ammoniacal silver nitrate, in the presence of neutral salts, or, better, of magnesium mixture, combines with all the purine bodies to form an insoluble salt of definite composition (see p. 425). The nitrogen in this can be estimated by Kjeldahl's method, and the result expressed as total purine nitrogen. This result is exceedingly useful in studying the metabolism of purine bodies. If

¹ On account of partial solubility of ammonium urate in water, it is necessary to add 3 mg. uric acid for every 100 c.c. of urine.

it be desired to determine the uric acid and the bases separately, a slight modification of the process is necessary.

Solutions necessary.—1. Magnesia mixture. This consists of 1 part crystallised magnesium chloride, 2 parts chloride of ammonium, dissolved in 8 parts of water and made strongly alkaline with 4 parts of ammonia. If the mixture be not quite clear (from the presence of magnesium hydrate) more ammonium chloride should be added.

2. Ammoniacal silver nitrate. Dissolve 26 gr. silver nitrate in about 300 c.c. water, add ammonia to this until the precipitate of silver oxide, which first forms, redissolves. Dilute the solution to one litre.

3. Kjeldahl's apparatus and solutions (see p. 410).

Determination.—240 c.c. protein free urine are mixed with 30 c.c. magnesia mixture, and the solution is made up to 300 c.c. by the addition of a 20 per cent. ammonia solution. This process is best done in a measuring cylinder. After the precipitate has settled, which it does in a few minutes, it is filtered through a dry folded filter and two portions of the filtrate are taken amounting to 125 c.c. each. Each of these corresponds to 100 c.c. of the original urine. They are both treated in exactly the same way, and should yield similar results. Each is mixed with 10 c.c. ammoniacal silver nitrate, and the mixture, after the precipitate has settled somewhat, filtered through an ash-free filter paper (of 10 c.m. diameter). The last traces of the precipitate are removed from the beaker by means of weak ammonia water. The next stage consists in washing the precipitate with distilled water until it is free from ammonia, as the presence of this would vitiate the determination of the nitrogen. In order to do this, the precipitate should be allowed to stand exposed to the air over night so that it may become partially dried, in which state the washing with water is much easier than when the precipitate is moist, for then it forms a gummy mass. The washing must be continued until the washings no longer react alkaline to litmus. In order to remove the last traces of ammonia, the filter paper, with the precipitate on it, is carefully removed to a Kjeldahl's combustion flask; about 50 c.c. of water are added, and then a little magnesium oxide. The mixture is then boiled, whereon the magnesia expels the ammonia. The boiling is continued until only about 10 c.c. of fluid remain, and then sulphuric acid, etc., are added, and the nitrogen determined.

To Determine the Bases and Acid separately.—Various methods are recommended. The simplest is probably to precipitate the bases by the Camerer method in the filtrate from which uric acid has been removed, as ammonium urate, as described under Folin's method.

Hippuric Acid.—In herbivorous animals a large amount of hippuric acid is excreted, but in man on an ordinary diet and in the carnivora only a small quantity. Hippuric acid may readily be obtained from the urine of a herbivorous animal by the following procedure. The urine is boiled for a few minutes with excess of milk of lime, filtered hot, concentrated on the water-bath, cooled and acidified with hydrochloric acid. Crystals of hippuric acid separate on standing, which are filtered off and dried. They may be freed from benzoic acid by extraction with petroleum ether, in which hippuric acid is insoluble, and recrystallised from hot water, using animal charcoal to decolourise if

necessary. Chemically hippuric acid is benzoyl glycine $C_6H_5 \cdot CO \cdot NH \cdot CH_2 \cdot COOH$. It may be synthesised by the action of benzoyl chloride on glycine, and decomposes to benzoic acid and glycine on heating with strong hydrochloric acid.

The presence of hippuric acid in urine is due to aromatic substances in the food, which are oxidised to benzoic acid in the body and excreted in combination with glycine. A vegetable diet is particularly rich in these aromatic substances. Hence the large quantity of hippuric acid in the urine of herbivorous animals.

Creatinin.—The chemical relationships of this body have already been discussed (see Muscile, p. 352). Urine always contains creatinin. On a creatinin-free diet the amount excreted per diem is remarkably constant for a given individual. So much so that a determination of creatinin in a urine of twenty-four hours from a person whose creatinin output is known affords a test as to whether the urine has been properly collected. Creatin is not normally present in urine unless large quantities of creatin are taken in the diet. It, however, makes its appearance in inanition and in carcinoma of the liver.

Tests for Creatinin.

EXPERIMENT VI. Weyl's Reaction.—To five c.c. of urine are added four or five drops of a very dilute solution of sodium nitro-prusside, so that the original colour of the urine remains unchanged. If a weak solution of caustic soda be now added drop by drop a ruby-red colour results, quickly changing to yellow. If an excess of acetic acid be added and the solution boiled, a greenish blue colour results, and after standing some time a blue sediment (Prussian blue) settles to the bottom of the tube.

Acetone gives a similar colour with the nitro-prusside and alkali, but it does not change to yellow on standing, and turns reddish purple on the addition of acetic acid.

Creatinin possesses, to a certain extent, the power of reducing metallic oxides in alkaline solution, and this must be remembered as a possible source of fallacy in testing for dextrose.

EXPERIMENT VII. Jaffé's Test.—Add a few drops of a saturated solution of picric acid in water and a few drops of caustic soda 10 per cent. solution to about 5 c.c. urine. A red colour is produced owing to the formation of picramic acid.

Estimation of Creatinin. Folin's Method.—For this purpose the urine must be free from aceto-acetic acid and hydrogen sulphide, and must contain not more than traces of acetone. Measure 10 c.c. urine with a pipette into a 500 c.c. graduated flask. Add 15 c.c. saturated aqueous picric acid solution (about 1·2 per cent.) and 5 c.c. 10 per cent. caustic soda solution. Mix and allow to stand

for five minutes. Fill up the flask to the 500 c.c. mark, and mix well. By means of a Dubosq or other suitable colorimeter determine the depth of liquid required to give in daylight an intensity of colour exactly equal to that given by a depth

of 8 mm. of a solution containing 24.55 gm. pure potassium bichromate per litre. The readings of the colorimeter, of which several should be taken, should be completed within twenty minutes of the dilution, as the reaction liquid frequently fades. The zero of both sides of the colorimeter should be tested, and it is as well to test the use of the colorimeter by employing the bichromate solution on both sides before determining the creatinin. The readings in the creatinin determination should not differ by more than 0.3 mm. If the average reading is less than 5 mm., the urines should

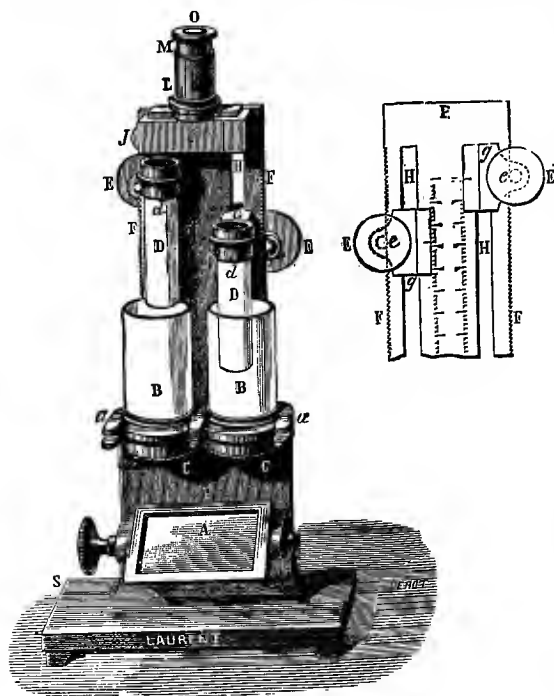

FIG. 246.—The Dubosq Colorimeter.

be carefully diluted and another determination made; if above 13 mm., 20 c.c. urine instead of 10 c.c. should be employed.

The result of the determination is calculated from the formula:—

$$x = \frac{10 \times 8.1}{a}$$

Where x is the quantity of creatinin in milligrammes in the volume of urine employed, and a is the colorimeter reading in millimetres. The amount of creatinin is inversely proportional to the colorimeter reading. The formula depends on the fact that, when 10 mg. of pure creatinin was employed for a determination, the colorimeter reading, against 8 mm. of standard bichromate, was 8.1 mm.

Estimation of Creatin.—Place in a flask, fitted with a cork and glass tube to serve as condenser, 10 c.c. urine and 5 c.c. N. HCl. Heat the flask in a boiling water bath for five hours. Cool to room temperature. Add sufficient caustic soda to neutralise the acid added, 15 c.c. picric acid solution and 5 c.c. 10 per cent. caustic soda. Allow to stand for five minutes. Wash the contents of the flask into a 500 c.c. flask, make up to 500 c.c., and proceed as for creatinin.

This determination gives the creatin and creatinin together, as creatin is converted by the acid into creatinin. The difference between this result and that for creatinin previously determined represents the amount of creatin present.

Ammonia.—In metabolism ammonia is the precursor of urea, being transformed to urea by the liver. The transformation to urea is never absolutely complete, so that urine always contains ammonia. In man under ordinary conditions the output of nitrogen as ammonia varies between 3 and 5 per cent. of the total nitrogen. When measured in terms of the equivalent amount of $\frac{N}{10}$ alkali, the ammonia is roughly equal to, or rather less than, the total acidity of the urine. When the nitrogen of the diet is low, the ammonia of the urine is decreased in absolute amount, but forms a greater percentage of the total nitrogen (see page 415).

The principal cause of a rise in the ammonia of the urine is the presence of acids, which require neutralisation, and so prevent the conversion of some ammonia into urea, the amount of ammonia rising more rapidly than the total acidity. From this cause the ammonia nitrogen may rise in pathological cases till it forms 40 per cent. of the total nitrogen. A similar effect is produced in dogs (carnivora) by the administration of hydrochloric acid. On the other hand, hydrochloric acid given to rabbits (herbivora) causes only a slight rise in the ammonia excretion. These animals rely on mineral bases to neutralise the acid, with the result that they are much more easily poisoned with mineral acid than dogs are. Similarly, ammonium chloride given to man and to dogs is mainly excreted unchanged, because the hydrochloric acid of the salt prevents the conversion of ammonia to urea, which takes place when ammonium carbonate is given; on the other hand, a large proportion of the ammonia of ammonium chloride given to rabbits is converted to urea.

EXPERIMENT VIII. Estimation of Total Acidity and Ammonia in Urine.—Weigh out roughly 15 grm. powdered potassium oxalate (neutral to phenol phthalein), place in a flask, and add from a pipette 25 c.c. urine and an equal volume of water. Add about 10 drops 1 per cent. alcoholic phenol phthalein. Mix and allow to stand for about a minute. Now run in $\frac{N}{10}$ caustic soda from a burette until the contents of the flask assume a slight pink tint. Read the burette. Measure into a small beaker 5 c.c. formalin (40 per cent. formaldehyde) and roughly 5 c.c. water, and add a few drops of phenol phthalein solution. Run in $\frac{N}{10}$ caustic soda till a slight pink colour is attained. Add this mixture

to the flask containing the neutralised urine. The pink colour disappears. Run in $\frac{N}{10}$ caustic soda until the colour returns, and take the reading.

The first reading of the burette gives the total acidity of 25 c.c. urine in terms of $\frac{N}{10}$ soda. Potassium oxalate is added to precipitate the calcium in the urine as calcium oxalate, as the formation of calcium phosphate would otherwise interfere with the end-point.

On the addition of neutral formaldehyde the ammonia in the urine combines with the formaldehyde forming a neutral compound, urotropine, thus liberating the acid which it previously neutralised. The second titration, therefore, determines the amount of ammonia present in terms of $\frac{N}{10}$ soda. To calculate the amount of nitrogen in grammes present as ammonia in the volume of urine taken multiply the reading of this titration in c.c. by 0.0014.

The method of determining ammonia is of sufficient accuracy for clinical purposes. The amount of ammonia is always higher by this method than by the more accurate methods which follow. This is due to the fact that formalin combines with amino acids, which are normally present in urine in minute traces, and thus renders them acid to phenol phthalein. This source of error is small, unless amino acids are present in excessive amount, as in cystinuria. The difference between the result of this method and that of one of the methods which follow affords a measure of the amount of amino acids present in the urine.

Estimation of Ammonia. Folin's Method.—Ammonia is liberated from its salts when a solution of the latter is made alkaline with a soluble carbonate, which, unlike a hydroxide, does not decompose the other nitrogenous bodies. By bubbling a fast current of air through such a mixture the ammonia is carried away and may be collected and measured by passing this air through standard acid. Excess of sodium chloride in the mixture not only preserves it against putrefaction, but encourages the evolution of the ammonia.

The technique of the method is as follows:—25 c.c. urine are placed in a large test tube *a* (Fig. 247) 2½-3 cm. diam. and 20-30 cm. long), and mixed with 8-10 grms. sodium chloride and 5-10 c.c. petroleum (to prevent excessive frothing), and lastly with 1 gm. sodium carbonate. The test tube is closed by an india-rubber stopper through which pass two tubes, the one for the air inlet passing to the bottom of the test tube, the other connecting the top of the test tube with a wide tube (U tube) *b* containing a loosely packed cotton-wool plug (to catch any particles of fixed alkali which might be sucked over with the air current). This safety tube is connected with a second test tube *c* (of the same size as the first) containing 15 c.c. $N/10$ H_2SO_4 + 5 c.c. water, the tubing being so arranged that the air bubbles through the acid. A third tube or bottle *d*, arranged in the

same way as the second and containing 10 c.c. $N/10$ acid and some ammonia free water, follows this, otherwise all the ammonia would not be caught by the acid. The tubing connected with this tube goes to a Buusen's air-pump e attached to a

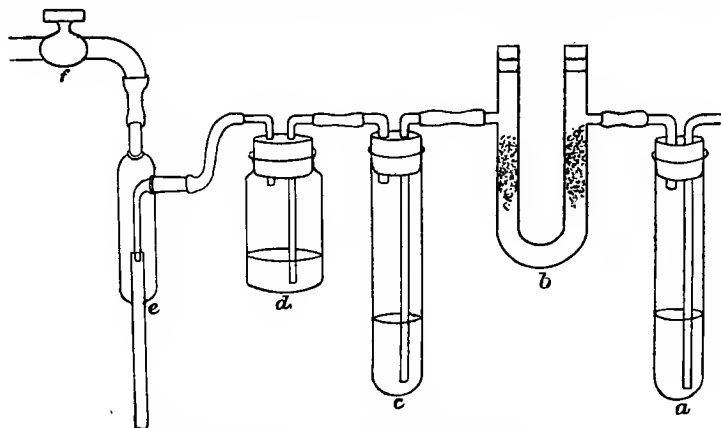

FIG. 247.—Folin's apparatus for estimating ammonia.

tap f . A quick stream of air (600-700 litres per hour) is made to pass through the apparatus for $1\frac{1}{2}$ hours. The acid in the two last test tubes is then washed into an Erlenmeyer flask and titrated with $N/10$ alkali. For titrating, Folin

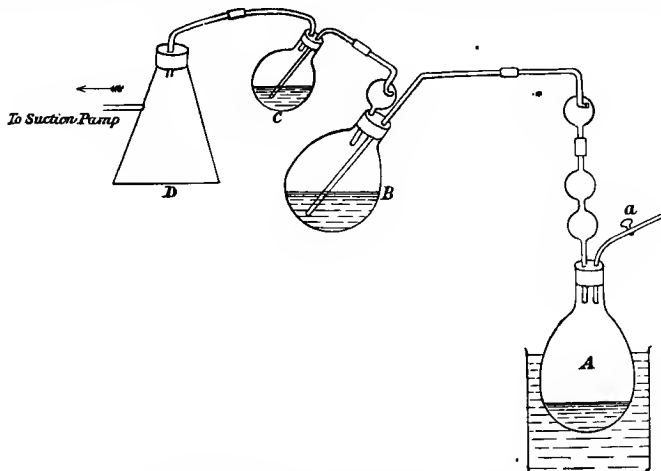

FIG. 248.—Shaffer's method of estimating ammonia in urine.

recommends 2 drops of a 1 per cent. solution of Alizarin red (for 200-300 c.c. fluid), the titration being carried on till a pink (not a violet) colour just appears. This indicator gives a better end-point than methyl orange.

Shaffer's vacuum distillation method of estimating ammonia in urine is as accurate as Folin's and much more rapid.

Place 50 c.c. urine in a round bottom $\frac{1}{2}$ litre flask *A* (Fig. 248), add 20 gm. sodium chloride to prevent decomposition and 50 c.c. methyl alcohol to reduce the boiling point of the mixture. In flask *B* place 50 c.c. or less *N*/10 acid and in *C* 10 c.c. *N*/10 acid, diluted in both cases with a little water. The flasks may be tilted obliquely, and should be large enough to prevent loss of acid by spraying during the violent commotion which is set up by the rapid passage of steam. If such loss should occur, the acid may be recovered by rinsing out the flask *D*. When the apparatus is ready, 1 gm. of dry sodium carbonate is added to the liquid in the flask *A*, the stopper is rapidly inserted and the suction started. The pump will quickly reduce the pressure to about 30 mm., and the liquid in *A*, which is warmed up to about 40° C. in a water-bath, will begin to boil. The temperature of the bath must be maintained and should not be allowed to rise above 50° C. for fear of decomposing urea. When the boiling has continued for fifteen minutes, all the ammonia will have been given off and the operation is stopped by slowly letting in air by the stop-cock *a*. The acid in *B* and *C* is titrated, after a few drops of a 1 per cent. solution of Alizarin red have been added as the indicator.

CHAPTER XIX.

THE INORGANIC ACID RADICLES OF URINE. URINARY DEPOSITS.

Chloride.

EXPERIMENT I. Add to urine a few drops of nitric acid, and then silver nitrate solution. A white precipitate of silver chloride forms, which is soluble in ammonia. The nitric acid prevents the precipitation of other silver salts such as phosphate.

Estimation of Chloride. Volhard's Method.—The chloride is precipitated by the addition of a known excess of silver nitrate in the presence of nitric acid, and the excess of silver nitrate determined by titrating a known part of the filtered solution with potassium sulphocyanide solution, which precipitates the silver, using ferric alum to indicate when the sulphocyanide has been added in slight excess.

Into a 100 c.c. graduated flask measure with a pipette 10 c.c. urine free from albumin. Add 5 c.c. pure nitric acid and 30 c.c. $\frac{N}{10}$ silver nitrate solution (17 gm. per litre) measured with a pipette. Add distilled water up to the 100 c.c. mark and rinse thoroughly. Filter the liquid through a dry chloride free filter into a dry clean beaker. Measure 50 c.c. of the filtrate with a pipette into an evaporating dish. Add 10 to 20 c.c. 10 per cent. ferric alum solution, and run in from a burette $\frac{N}{10}$ potassium sulphocyanide

solution (9.73 grm. per litre), until on stirring the liquid assumes a permanent slight red colour. Take the reading on the burette. Let this be a c.c. Then the amount of chloride ($-Cl$) in the 10 c.c. urine employed is equal to $(30 - a) 0.00355$ grm. The sulphocyanide solution must be exactly equivalent to, or standardised in terms of, the silver nitrate solution.

Phosphate.

EXPERIMENT II. Boil some solution of ammonium molybdate in nitric acid in a test tube, and add drop by drop boiling urine acidified with nitric acid. A yellow precipitate indicates the presence of phosphate.

EXPERIMENT III. Make urine alkaline by the addition of ammonia. A white precipitate of calcium and magnesium phosphate forms. Filter off this precipitate and prove that it contains phosphate by the molybdate test.

Estimation of Phosphate.—Standard uranium nitrate solution is added to urine in the presence of sodium acetate and acetic acid until all the phosphate is precipitated, as shown by the presence of slight excess of uranium in the solution. Sodium acetate is added so as to prevent the liberation of nitric acid, in which uranium phosphate is soluble. The acetic acid serves to prevent the precipitation of other uranium compounds than the phosphate and to dissolve any calcium phosphate present.

Place 50 c.c. urine in a porcelain basin. Add 5 c.c. of a solution containing 100 grm. sodium acetate and 100 c.c. glacial acetic per litre. Heat the basin and run in from a burette a standard solution of uranium nitrate, until a drop of the solution, placed on a small heap of powdered potassium ferrocyanide on a white tile gives an immediate brown colour, due to the formation of uranium ferrocyanide. The most convenient standard solution of uranium nitrate contains 35.5 grm. per litre. 1 c.c. of this solution is equivalent to 0.005 grm. phosphoric acid (P_2O_5).

Sulphates and Neutral Sulphur.—There are two varieties of sulphates in the urine, each of which has a special significance of its own. These varieties are :

1. Inorganic sulphates (sodium sulphate, potassium sulphate, etc.).

2. Ethereal sulphates (phenyl sulphate of potassium) $SO_2 \begin{matrix} \text{OK} \\ \text{OC}_6\text{H}_5 \end{matrix}$.

(inodoxy sulphate of potassium) $SO_2 \begin{matrix} \text{OK} \\ \text{OC}_8\text{H}_6\text{N} \end{matrix}$.

Under ordinary conditions the ethereal sulphates constitute only

about 10 per cent. of the total sulphate excretion. The neutral sulphur is present in organic compounds, such as cystin.

EXPERIMENT IV. Place about 10 c.c. of urine in a test tube and dilute with water to about 20 c.c. Add about 2 c.c. of hydrochloric acid (1 part HCl(conc.) + 4 parts water), and then drop by drop about 2 c.c. of 5 per cent. solution of barium chloride. A white precipitate of barium sulphate forms, due to the presence of inorganic sulphates. After allowing the test tube to stand for a few minutes, filter and boil the clear filtrate with a few drops more of hydrochloric acid and barium chloride solution. There is another precipitation of barium sulphate due to *ethereal sulphates* which have been decomposed by boiling with hydrochloric acid.

Quantitative determination.—There is no volumetric method, that is even approximately accurate, available for this purpose, so that it is necessary that a good analytical balance be at command. For accurate work it is further necessary that great care be exercised in carrying out the processes, for the final precipitates are otherwise apt to be quite impure and the estimation inaccurate.

The following processes have been worked out by Folin, and the directions must be implicitly followed. Protein must be removed if present. This is best done by boiling the urine acidified with acetic acid in a flask, cooling and filtering.

EXPERIMENT V. Inorganic Sulphates.—25 c.c. of urine are diluted with 100 c.c. of water in an Erlenmeyer flask (of 250 c.c. capacity) and 10 c.c. of dilute hydrochloric acid (1 part HCl (con.) to 4 parts water) added. A burette containing a 5 per cent. solution of barium chloride is then placed over the mouth of the flask and 10 c.c. of the reagent allowed to drop into the contents of the flask at a slow rate (not quicker than 5 c.c. per minute).¹ The flask must not be shaken until after the end of an hour,² when it is shaken and the precipitate collected on an asbestos mat in a Gooch crucible, washed with about 250 c.c. cold water, dried and ignited. In doing this, the flame must not be applied directly to the perforated bottom of the crucible, but the crucible must be laid on a crucible lid or specially fitting platinum bottom. The crucible must also be covered with a lid during the ignition. Ten minutes' ignition is sufficient.

EXPERIMENT VI. Total Sulphates (Inorganic and Ethereal).—By boiling the urine with acid, nearly all of the ethereal sulphates are decomposed. 25 c.c. urine are mixed with 20 c.c. of dilute hydrochloric acid (1:4) in an Erlenmeyer flask of about 250 c.c. capacity, and, after covering the mouth of the flask with a watch-glass, gently boiled for 20 to 30 minutes. The flask is then cooled in running water, its contents diluted with distilled water to about 150 c.c. and 10 c.c. of 5 per cent. solution of barium chloride added, and the further procedure followed as above described.

EXPERIMENT VII. Ethereal Sulphates.—It is sufficiently accurate to calculate this as the difference between I. and II. If a direct estimation is desired as a

¹ More rapid addition of the reagent causes the results to be too high, i.e. produces an impure precipitate.

² Shaking the solution too soon will lower the result, because the precipitate will lose sulphuric acid during ignition.

check, it may be made by diluting 125 c.c. of urine with 75 c.c. water, adding 30 c.c. dilute hydrochloric acid (1 : 4) and precipitating the inorganic sulphates with 20 c.c. of 5 per cent. solution of barium chloride, as above described. After standing for one hour the mixture is filtered through a dry filter and 125 c.c. of the clear filtrate, corresponding to 62.5 c.c. original urine, boiled for not less than 30 minutes, whereby a precipitate of sulphate forms on account of the decomposition of the ethereal sulphates. After allowing the solution to cool, this precipitate is collected on a Gooch crucible, washed, ignited, and weighed.

EXPERIMENT VIII. Total Sulphur.—25 c.c. urine (or 50 c.c. if very dilute) is mixed in a large nickel crucible (of 200 to 250 c.c. capacity) with 3 grams of sodium peroxide. The crucible is then carefully heated until its contents solidify (about 15 minutes), after which it is cooled, the fused mass moistened with 1.2 c.c. of water about 7 grms. of sodium peroxide sprinkled over it, and again heated to cause its contents to become completely fused; the mass is kept fused for ten minutes, then allowed to partially cool, 100 c.c. water added and the contents boiled for half an hour. This dissolves the alkali and decomposes all the sodium peroxide. The contents of the crucible are transferred to an Erlenmeyer flask (400—450 c.c. capacity) and the crucible washed into the flask with hot water, the volume of the resulting solution made up to about 250 c.c., and then brought almost to the boil; concentrated hydrochloric acid is now slowly added until the nickelic oxide just dissolves (about 18 c.c.) and the mixture is boiled until it becomes clear. (If it does not become clear by this treatment, it must be cooled and filtered.) 5 c.c. of dilute alcohol (1 : 4) is then added and the boiling continued for a few minutes, so as to remove traces of chlorine.

The solution is now ready for precipitation of the sulphates, into which, by the above procedure, all the sulphur has been converted. To do this 10 c.c. of 10 per cent. solution of barium chloride is added drop by drop, as above described, and the mixture allowed to stand for *two days*,¹ after which the precipitate is collected and weighed as above described.

EXPERIMENT IX. Neutral Sulphur.—This is obtained by subtracting the total sulphates (No. 2) from the total sulphur.

It will be seen that at least three separate estimations must be carried through to obtain all the desired data—(1) inorganic sulphates, (2) total sulphates, and (3) total sulphur. The ethereal sulphates and the neutral sulphur can be calculated by difference.

These values can be calculated as S or SO₃ according to the following ratios :—

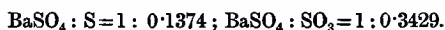

Metabolism.—One of the results of Folin's investigations on metabolism has been to show the significance of determinations of sulphates in the urine. The total sulphur in the urine is, like the nitrogen, distributed among several substances, which are divided into three groups—the inorganic sulphates, the ethereal sulphates, and the neutral sulphur compounds. The inorganic sulphates are mainly those of sodium; the ethereal sulphates are compounds of phenol, cresol skatoxyl, and indoxyl, with sulphuric acid and potassium (see p. 435), and the neutral sulphur compounds are organic compounds in which

¹ It takes this length of time to ensure complete precipitation.

the sulphur is an integral part of the molecule. Cystin, when present, belongs to this group. When the relative amounts of SO_3 excreted in the above-mentioned three forms are calculated as percentages of the total SO_3 excretion, it is found that the inorganic sulphates on a protein poor diet behave like urea-nitrogen, *i.e.* become less both in absolute amount and in relative percentage; that the neutral sulphur under the same conditions behaves like creatinin-nitrogen, *i.e.* remains constant in absolute amount, whereas the percentage rises and that the ethereal sulphate excretion behaves like that of ammonia-nitrogen, *i.e.* becomes somewhat less in absolute amount, but that the percentage rises.

These facts are clearly shown in the following table, which is an extension of that on page 415.

	N-rich diet.		N-poor diet.
Volume of urine,	1170 c.c.		385 c.c.
Total nitrogen,	16.8 grm.		3.60 grm.
Total SO_3 ,	3.64 grm.		0.76 grm.
Inorganic SO_3 ,	3.27 grm. = 90.0 % of total S.		0.46 grm. = 60.5 % of total S.
Ethereal SO_3 ,	0.19 grm. = 5.2 %	,,	0.10 grm. = 13.2 %
Neutral SO_3 ,	0.18 grm. = 4.8 %	,,	0.20 grm. = 26.3 %

The ethereal sulphates cannot, as has been supposed, derive their source entirely from the aromatic bodies formed in the intestine by micro-organismal growth. When this is excessive, or when there is obstruction in the small intestine so that an excessive amount of these aromatic bodies is absorbed, an increase no doubt occurs in the ethereal sulphate excretion, but this increase can be no reliable index of intestinal putrefaction, since the relative ethereal sulphate excretion becomes greater when the diet contains little or no protein. Practically the only source of sulphur intake by the food is in proteins. Sulphates are not taken unless for medicinal purposes, because of their disagreeable taste. The sulphur excretion by the urine is therefore a measure of protein katabolism in the organism.

URINARY DEPOSITS.

Normal urine is quite clear when it is passed, but, on standing some time, a sediment usually separates out, and this varies somewhat under different conditions.

Acid Urine from a healthy person may deposit the following:—

1. **Urates** (see p. 424).—The sediment has a chalky appearance and is usually tinged reddish by uroerythrin. It disappears on warming the urine. Examined microscopically, it is generally amorphous, but may show a crystalline structure, usually as needles, or as balls with spines projecting from them (Fig. 249). It is composed mainly of sodium urate.

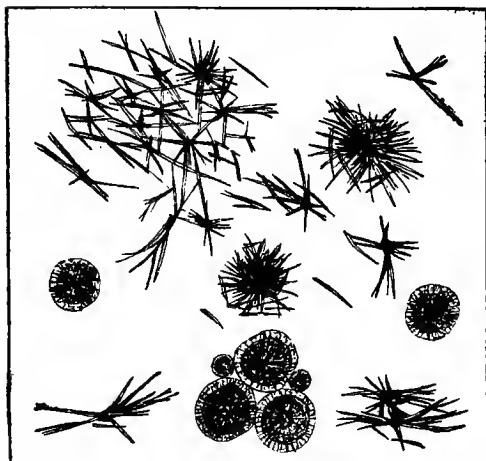

FIG. 249.—Sodium urate. $\times 350$.

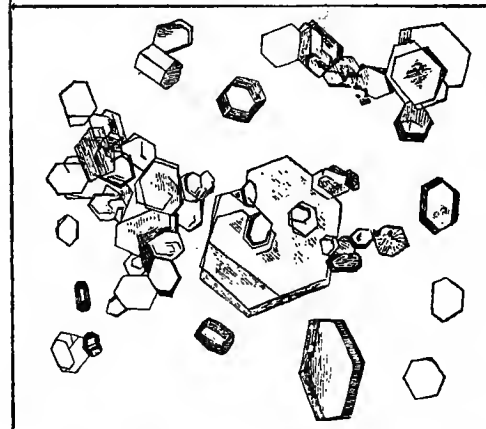

FIG. 250.—Cystine. $\times 350$.

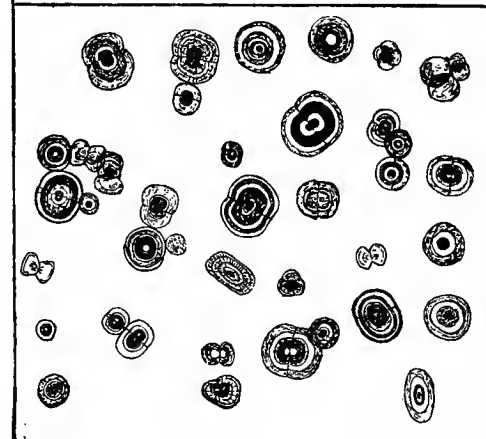

FIG. 251.—Calcium carbonate (from human urine). $\times 400$.

2. **Uric Acid.**—This may be split off from the urates as described on p. 424. It appears as a cayenne pepper-like sediment, and has a definite crystalline appearance under the microscope (Fig. 245). The crystals may vary much in shape, but are always large and tinged a reddish colour. The most usual shapes for the crystals to assume are “sheaves,” “whetstones,” “rhombic tables,” and sometimes “dumb-bells.” The presence of the crystals does not necessarily indicate an increased

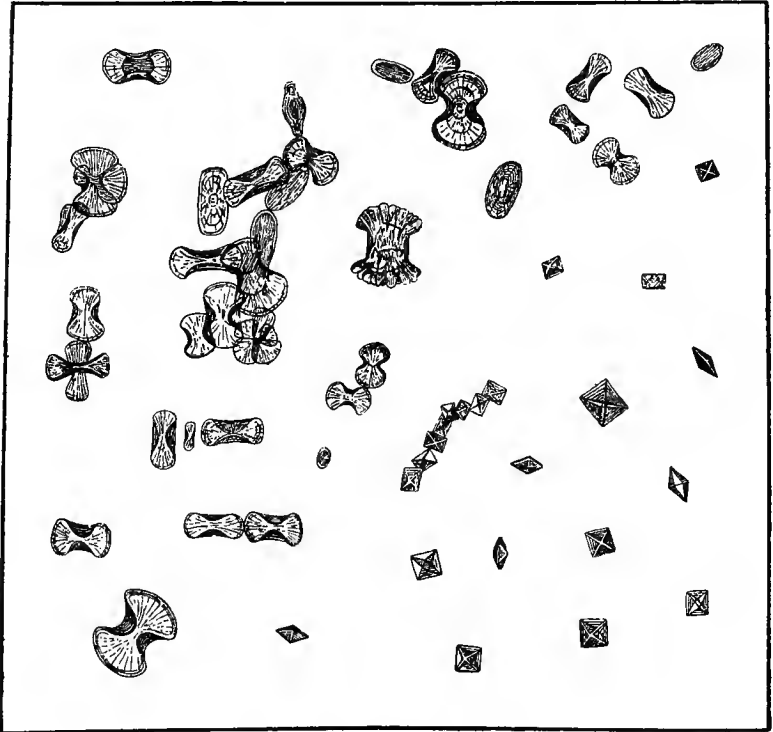

FIG. 252.—Calcium oxalate. $\times 500$.

excretion of uric acid, but depends on the concentration and acidity of the urine.

3. **Calcium Oxalate.**—This is usually a scanty deposit, adhering to irregularities on the surface of the glass of the urine jar, or forming a glistening layer on the top of the mucous deposit that settles at the bottom.

The crystals are insoluble in acetic acid. This reaction distinguishes them from phosphates or carbonates. They are also insoluble in ammonia, and are thus distinguished from urates.

Microscopically they are seen to be very small octahedra, often flattened along one axis, so that they appear like squares with diagonal lines (hence called "envelope" crystals, Fig. 252).

Acid urine from a person suffering from disease, or during the administration of certain drugs, may deposit:—

1. **Cystin.**—This forms a deposit somewhat like that of urates in appearance.

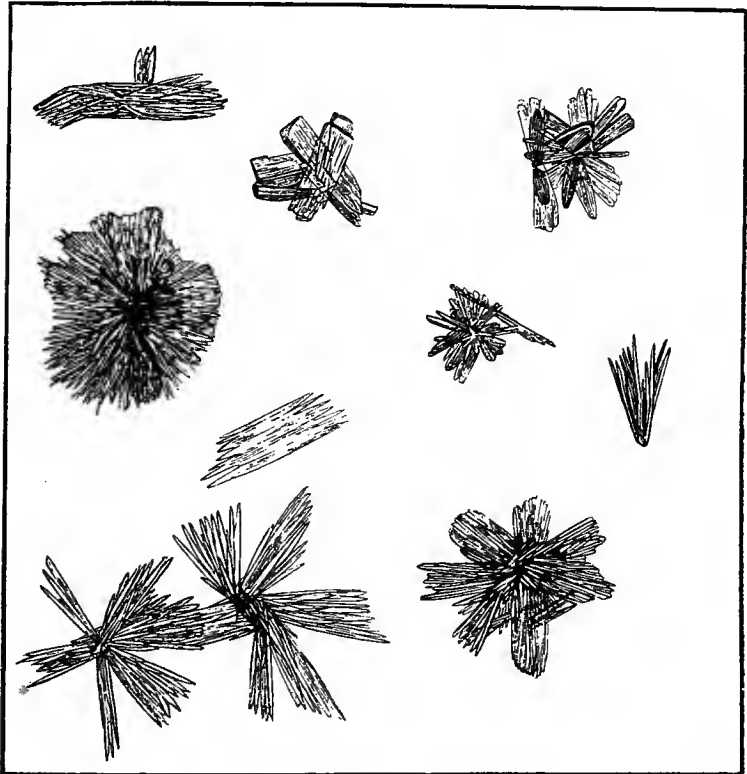

FIG. 253.—Stellar phosphate of calcium. $\times 500$.

Microscopically, however, it shows a distinct crystalline structure consisting of hexagonal colourless plates or slabs (Fig. 250). When the crystals are present the condition is called cystinuria (see p. 438).

2. **Leucin and Tyrosin.**—Though very rarely, these two bodies sometimes occur in urine (*e.g.* in severe hepatic disease), where their appearance is similar to that in a pancreatic digest (see Fig. 236).

3. **Hippuric Acid.**—This may appear in urine during the administra-

tion of benzoic acid. It crystallises in four-sided prisms. It is quite common in the urine of herbivora.

In Alkaline Urine the following may occur:—

1. **Phosphates.**—Of these there are two kinds, viz. phosphate of calcium and ammonium-magnesium phosphate.

(a) Phosphate of Calcium.—The sediment is chalky and never pigmented; it clears up on adding a few drops of nitric acid; it is increased by boiling. Microscopically it is usually amorphous, but may exist as long prismatic crystals arranged in star-shaped clusters, hence called *Stellar Phosphates* (Fig. 253). The crystalline form may also occur in faintly acid urines.

(b) Ammonium-magnesium Phosphate, Triple Phosphate.—When urine gets stale and ammonia develops in it, a white sediment and a white surface film form. Under the microscope these are seen to be made up of large clear crystals like “*knife rests*,” or, if excess of ammonia be present, they may look like “*feathery stars*.” This latter type can be easily obtained by adding ammonia to normal urine (Fig. 254).

2. **Urate of Ammonia.**—This looks like the urate of soda crystals, but is associated with crystals of phosphates, and occurs in an alkaline urine.

3. **Carbonates.**—In the urine of vegetarians these are not uncommon. The urine effervesces on adding acetic acid. Microscopically the sediment is usually amorphous, but may exist as biscuit-shaped crystals or as dumb-bells (Fig. 251).

CHAPTER XX.

PATHOLOGICAL URINE.

I. **Proteins in the Urine—Albuminuria.**—Traces of mucin or nucleoprotein may be added to the urine in its passage along the urinary tract, but otherwise healthy urine does not contain any protein. When the kidneys or urinary passages are diseased, however, a certain amount of the plasma proteins leak into the urine, where they can be recognised by certain tests, the condition being called *Albuminuria*.

Also when proteins other than *serum* albumin and globulin gain access to the blood, they are at once excreted in the urine. It is on this account that albuminuria results after the consumption of a large number of raw eggs (egg flip), because the intestinal epithelium allows a certain amount of the unchanged albumin to pass into the blood,

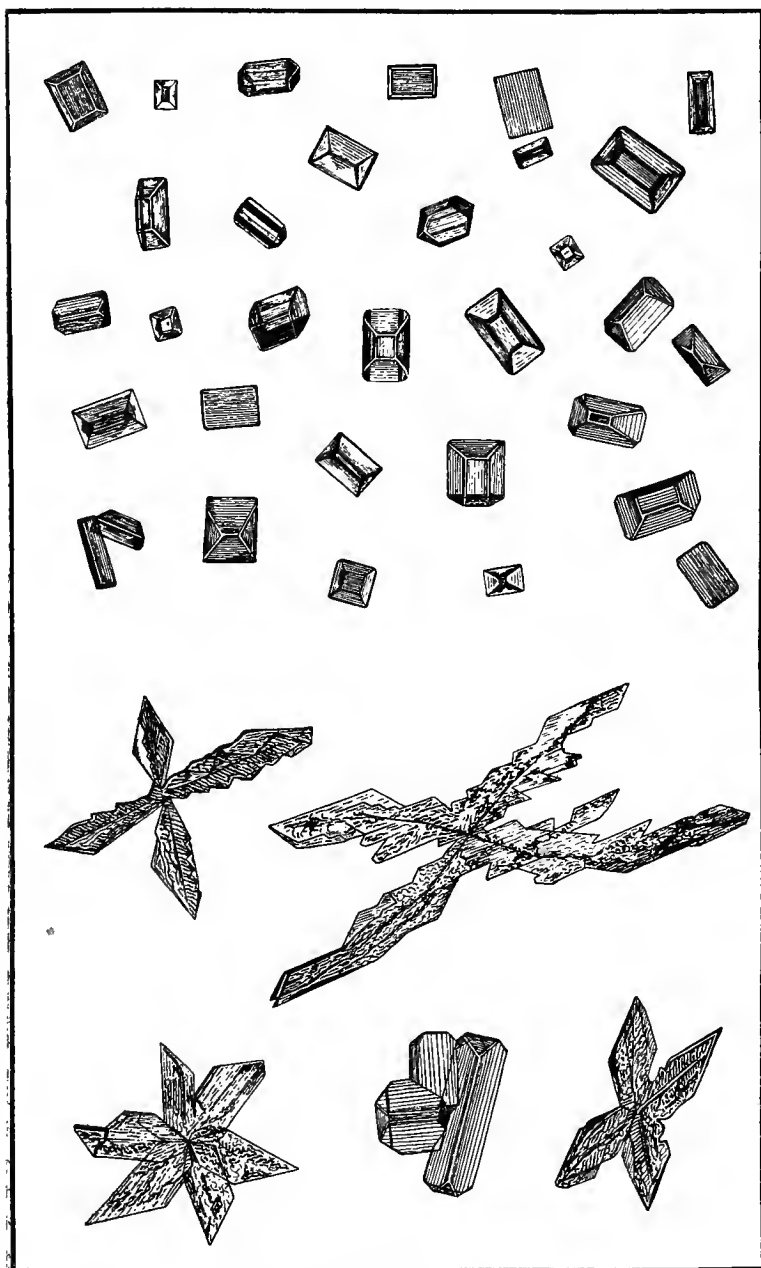

FIG. 254.—Triple phosphates. $\times 400$.

where it is foreign (in being egg- and not serum-albumin), and is consequently immediately excreted by the kidneys. In disease of the red-bone marrow, a body somewhat similar in its reactions to a proteose is added to the blood and is excreted by the urine (Bence Jones' proteose-uria).

Although globulin may occur along with albumin in the urine, or even in some cases independent of it, it is of no practical importance to distinguish between them, so that the tests about to be described include both bodies.

The tests employed depend on certain of the reactions described under proteins. It is obvious that the colour reactions will not be applicable to the urine; those employed depend on the production of coagula. The most important of these are:—

1. **Heat Coagulation.**—EXPERIMENT I. Place some *clear* urine in a test tube, and boil. A white turbidity or coagulum indicates the presence of either albumin or phosphates (earthy phosphates are precipitated by boiling). To the boiling solution, whether it show a turbidity or not, add 3-4 drops of concentrated nitric acid. If due to phosphates, the turbidity will disappear, but will remain if due to protein. In nitric acid any acid- or alkali-albumin which the urine may contain is insoluble. Where there is doubt as to the occurrence of a haze, the test tube should be about three-quarters filled, and only the upper layer should be boiled, the test tube being meanwhile held low down. By holding it against a dark background the slightest haze becomes very evident by this method, on account of contrast with the unboiled layer beneath.

2. **Heller's Test.**—EXPERIMENT II. Place some clear urine in a test tube. Hold the test tube in a slanting position, and allow concentrated *pure* nitric acid to run *very slowly* down the side, so that it forms a layer underneath the urine. Where the two meet, a sharp white ring (of coagulated acid albumin) is formed. The test may also be done by placing the nitric acid first in the test tube, and covering this with the urine slowly delivered from a pipette. The ring does not disappear on warming. A similar ring may be obtained when proteoses are present, but in this case the ring clears up on gently warming the test tube, and reappears on cooling. In warming, very great care must be taken that no mixing of the two layers occurs. When mucin is present in excess a *diffuse haze* may be produced in the portion of urine next the acid. Certain resin acids which may appear in the urine after the administration of such drugs as copaiba also give a haze by Heller's test. Also when the urine is very concentrated, acid urates or urea nitrate crystals may develop and simulate the reaction. In these cases,

the urine should be diluted with two or three times its bulk of water, and the test reapplied, when very little doubt will remain as to the reaction.

3. Salicyl-Sulphonic Acid Test.—This is perhaps the most delicate of all the tests.

EXPERIMENT III. Add to about 10 c.c. of urine a drop or two of a saturated solution of pure salicyl-sulphonic acid. A white precipitate results, which on boiling changes into a number of coagula.

This reaction occurs in a dilution of 1-230,000 albumin. The only other body with which this reagent produces a precipitate is proteose, in which case, however, the precipitate disappears on warming.

The reagent, if pure, keeps indefinitely. If impure, however, it turns red on keeping. It has the great advantage over nitric acid in being non-corrosive, and therefore easily carried about (MacWilliam).

There are numerous other tests, but their application is superfluous if the above be properly applied.

Proteoses are detected by the precipitates produced by nitric and salicyl-sulphonic acids clearing up on heating the urine, and returning when it is cooled. The so-called "proteose" in Bence Jones' proteosuria is coagulated by moderate heat, but redissolves on boiling the urine. Proteose can best be separated from albumin by adding salicyl-sulphonic acid, boiling and filtering. The coagulated albumin remains on the filter paper, and the proteose is gradually precipitated in the filtrate as it cools.

Quantitative Estimation of Albumin.—For clinical purposes this is done by means of *Esbach's albuminometer* (Fig. 255). The determination is made by measuring the depth of the coagulum produced by adding to the urine Esbach's reagent (a mixture of 10 grms. picric acid and 20 grms. citric acid in 1000 c.c. distilled water).

EXPERIMENT IV. Place clear urine, filtered if necessary, in an Esbach's tube up to the mark *U*. If the reaction be alkaline, render slightly acid by the addition of acetic acid; and if the specific gravity be above 1008 dilute it with water till this density, or something below it, is obtained.¹ Now add the reagent up to the mark *R*. Close the tube with a tightly-fitting cork and invert several times, so as to mix

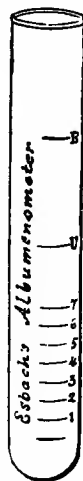

FIG. 255.—Esbach's albuminometer.

¹These corrections should be made before the urine is measured into the Esbach's tube.

the fluids thoroughly. Allow to stand in an upright position for twenty-four hours, and then read off the graduation corresponding to the top of the precipitate. This gives the number of grammes of dried albumin per litre of urine used. If the urine has been diluted the necessary calculation must be made in order to obtain the percentage in the original urine.

For more accurate estimation of albumin, Scherer's method is employed.

ADVANCED EXPERIMENT. Place 50-100 c.c. urine (according to amount of albumin in it) in a large-sized evaporating dish, and, while stirring, bring to the boil. Carefully add a few drops of dilute acetic acid, and allow the coagulum to settle down. If the supernatant fluid is opalescent, add a little more acetic acid, and bring again to the boil. (It is very important to use as little acetic acid as possible, so that acid albumin may not be formed.) The coagulum must then be collected on a small ash-free filter paper which has been dried between watch-glasses at 120° C. After being collected on the filter, wash the coagulum with boiling water, followed by alcohol and ether, and dry it at 120° C. until the weight is constant. Since the coagulum contains considerable ash, the filter and coagulum must now be transferred to a weighed crucible, incinerated, and the weight of ash deducted from the weight of dried coagulum.

Mucus, Pus, and Casts in Urine.—When the kidneys or urinary passages are diseased, besides protein there may be a considerable deposit of mucus in the urine. This body has the general properties and solubilities of mucin (see p. 308), but may consist largely of nucleo-protein. Casts also occur in the deposit from the urine. When these come from the urinary passages, they consist of groups of flattened epithelial cells. When they come from the kidney tubules, they are tubular and consist of polyhedral cells, showing various stages of degeneration. When the kidneys or urinary passages are infected by micro-organisms, pus cells occur in the urine and form a deposit. Strong potash dissolves the pus, forming a viscid solution. Pus also gives a guiac test as for blood, but much more slowly and not after boiling, which destroys the oxidases to which the test is due. The only certain test for pus, however, is to examine the urine or deposit with the microscope. The pus cells appear as colourless, spherical, highly refractive granular bodies, about $9\ \mu$ in diameter, the nuclei of which can be stained by adding dilute methylene blue. The urine is usually acid when the pus comes from the kidney, and alkaline when the pus comes from the bladder, due to the decomposition of urea and ammonium carbonate.

Haemoglobin in Urine.—This may be due to bleeding from the kidneys or urinary passages, when it is called *haematuria*, or to excretion of haemoglobin or methaemoglobin from the blood plasma by the kidneys, called respectively *haemoglobinuria* and *methaemoglobinuria*.

In any case the tests for haemoglobin can be applied. The guiac test, which is very sensitive, should be applied after boiling the urine to destroy oxidases. The spectroscopic examination is also very sensitive when an adequate depth of urine is employed (see p. 344).

Haematuria is distinguished by the smoky appearance of the urine and by examination of the urine, or deposit on centrifugalising, when red blood corpuscles are seen. The spectroscope nearly always shows the presence of oxyhaemoglobin. Blood from the kidney is mixed with the urine. That from the bladder is often present as a clot. If the red corpuscles have disintegrated, the urine will present the appearance of haemoglobinuria. If the urine is stale, methaemoglobin may be present.

In **Haemoglobinuria** and **Methaemoglobinuria** red blood corpuscles are not seen, and the urine is clear, not smoky. The two conditions are distinguished by the colour of the urine and by the spectroscope.

EXPERIMENT V. Test the urine supplied for blood and haemoglobin.

Bile in Urine.—When the bile duct is blocked by a calculus, or its mucous membrane is swollen from catarrh, the bile, which accumulates in the bile channels, is reabsorbed into the blood-vessels and carried to the tissues, which become stained with bile pigment. Under these conditions the urine contains bile constituents, the most easily recognised of which are the bile pigments.

EXPERIMENT VI. Apply Gmelin's test (see p. 400) to the urine of a jaundiced patient. Where only a small quantity of bile pigment is present it is better to concentrate the pigment by proceeding as follows:—Add calcium chloride solution to the urine, and then sodium carbonate solution, so as to form a precipitate of calcium carbonate and phosphate, which carries down the pigment; filter off the precipitate and dissolve it in as small a volume of hot dilute hydrochloric acid as possible; apply Gmelin's test to this solution.

Also apply Matthew Hay's sulphur test for bile salts (see p. 398).

II. **Sugars in the Urine.**—In the *disease* known as diabetes mellitus, the most important symptom is the presence of dextrose (or glucose) in the urine, or, in other words, **glycosuria**. This condition can also be produced *experimentally*: (1) *By puncture of the floor of the fourth ventricle.* The cause of the glycosuria in this condition is an excessive conversion of glycogen to glucose in the liver, whereby the percentage of dextrose in the blood rises above the normal, the excess being excreted by the kidneys. The glycosuria ceases when all the liver glycogen has been used up, and it cannot be produced by a similar experiment in animals which have been previously starved to remove the glycogen from the liver.

(2) *By extirpation of the Pancreas.*—If the whole of the pancreas be removed in dogs, glycosuria is at once established, and the blood will be found to contain an excess of dextrose. So far, then, the cause of the glycosuria is the same as in the previous condition, viz. an excess of sugar in the blood. If, after the condition has existed several days, the liver be examined it will be found to be glycogen-free, but, unlike the previous condition, the glycosuria still continues, and in a few days it will be noticed that the animal has become markedly emaciated. The cause of the emaciation is that the protein tissues are undergoing dissolution. That such is actually the case is proved by a determination of the nitrogenous excretion, which will be found to be enormously increased in amount. In the course of a few weeks the animal dies of emaciation.

These results show us that the pancreas must possess, besides its digestive function, some controlling influence on the metabolism of carbohydrates.

(3) *The administration of certain drugs, more especially of Phloridzin.*—The administration of this drug is immediately followed by glycosuria, which, however, ceases after a few hours. If the liver be examined at this stage it will be found that a large proportion of its glycogen has disappeared. If a second dose be administered the glycosuria will reappear, and will persist so long as the drug is administered, and even after all glycogen has been used up. After some time, however, the animal becomes very emaciated, this being accompanied by an excessive excretion of nitrogen.

The percentage of sugar in the blood is normal, or even sub-normal. On this account, it is supposed that phloridzin produces glycosuria by disturbing the controlling mechanism of the kidney, whereby the latter allows too much dextrose to escape into the urine, in consequence of which the percentage tends to become sub-normal in the blood. Increased demands are therefore made on the stored-up glycogen, which at last becomes used up, and then the supply has to be furnished by the proteins, and these break down.

In both pancreatic and phloridzin diabetes, therefore, protein is an important source of the excess of dextrose. It has been conclusively shown now that it is from the amino acids, etc., that some of the dextrose is derived.¹

The other sugars which the urine may contain are lactose and pentose. The former of these is sometimes found in the urine of nursing mothers, and the latter appears in the urine whenever pentoses (Wood Sugars, p. 294) are given in the food.

¹The conversion of fat into glucose is also possible.

Tests for Dextrose in the Urine.—The tests for dextrose, as described, can, with slight modifications, be applied to its detection in urine.

The most important of these are:—

EXPERIMENT VII. Fehling's Test.—Boil 5 c.c. of Fehling's solution in order to ascertain that the Rochelle salt which it contains has not decomposed into reducing bodies. If no reduction occur, add a drop of the suspected urine and boil again. If no result, go on adding small quantities, boiling between each addition, till 5 c.c. have been added.

Fehling's test is quite satisfactory, when sugar is present in considerable quantity. When the amount of reduction is small, however, it may be due to the presence of other substances than sugar. In such cases the following tests should be applied, as they are positive for sugars only.

EXPERIMENT VIII. Boettger's Test.—To 10 c.c. urine add 1 c.c. Nylander's reagent.¹ Heat for five minutes on the water bath. If sugar is present to the extent of at least 0·08 per cent., a black precipitate of bismuth forms.

EXPERIMENT.—**Worm Müller Test.**²—In one test tube mix 1 c.c. copper solution and 2·5 c.c. alkaline Rochelle salt solution. Place 2·5 c.c. urine in another test tube. Bring the contents of both test tubes simultaneously to the boil. After allowing to cool for 25–30 sec. pour the blue reagent into the urine and without shaking place the test tube on the rack. In the presence of a pathological amount of dextrose, a finely suspended yellow precipitate will develop within 10 minutes. If the solution should turn red but no precipitate develop the result is negative; in such a case repeat the test, using 3 c.c. of copper solution.

Though not so delicate, the following tests are valuable, in that they indicate the nature of the sugar:—

1. **The Fermentation Test.**—**EXPERIMENT IX.** Place some diabetic urine in a small beaker, and boil it on a sand bath for ten minutes, to expel any air it may contain. Cool the urine and test its reaction; if alkaline, render faintly acid with a weak solution of tartaric acid. (This precaution is necessary in order to prevent putrefaction, which would lead to the evolution of ammonia.) Add a small piece (about

¹ Nylander's solution: dissolve 4 grm. Rochelle salt in 100 grm. of a caustic soda solution of 1·12 sp. gr.; add 2 grm. Bismuth subnitrate and heat on water bath until it is dissolved.

² Worm Müller solutions: 1, 2·5% solution of copper sulphate; 2, Dissolve 10 grm. of Rochelle salt in 100 c.c. of a 4% solution of caustic soda.

the size of a split pea) of German yeast, and stir it in the urine until a milky solution is obtained. Now transfer the fluid to a Doremus ureometer (Fig. 244) so that the upright limb is completely filled with fluid. Place this in an incubator, or in a warm place, as on the mantelpiece, over night when it will be found that gas—carbon dioxide—has collected in the upper portion of the vertical limb.

Two control tubes—one with a weak solution of dextrose and yeast, the other with normal urine and yeast—should be arranged so as to prevent any fallacy due to inactive or impure yeast.

Instead of using a Doremus ureometer a test tube inverted in a trough of mercury may be employed.

Lactose and pentose do not give a positive result by this test.

2. The Phenyl Hydrazine Test.—The method of employing this is described on p. 275. The obtaining of characteristic dextrosozone crystals is positive evidence of the presence of dextrose; glycuronic acid (p. 454) also gives crystals, but less readily.

Estimation of Dextrose in Urine.—The polarimeter (see p. 282) may be employed for the estimation of dextrose in urine. The main objection to its use is that other optically active bodies besides dextrose, *e.g.* glycuronic acid and oxybutyric acid, which are laevo-rotatory, occur in diabetic urine, and therefore to a certain extent vitiate the result. The other method is to determine the reducing power of the urine. For clinical purposes the methods of Fehling, Gerrard, and Pavy are employed. In Fehling's method the amount of urine necessary to decolourise a measured quantity of standard Fehling's solution is determined. It is, however, difficult to observe when the blue colour of the Fehling's solution has disappeared owing to the precipitation of red cuprous oxide. To obviate this difficulty Gerrard prevents the precipitation of cuprous oxide by the addition of potassium cyanide. The solution when reduced has a light yellow tint, so that the end-point is a little troublesome, but for the use of students this is probably the best method. In Pavy's method ammonia is added to the Fehling's solution. There is then no precipitation of cuprous oxide until the ammonia has been boiled off. The reaction liquid is perfectly colourless when reduced, so that the end-point is a good one, but the ammoniacal solution absorbs oxygen from the air, so that the liquid has to be kept boiling in a flask with a small opening. Moreover, owing to the escape of ammonia there is only a limited time in which to perform the titration before cuprous oxide begins to be precipitated. This method, therefore, although very rapid, requires considerable practice.

Fehling's Method.—The *standard solution* contains 34.64 grm. pure

crystallised copper sulphate, 180 grm. Rochelle salt and 70 grm. caustic soda per litre. 10 c.c. of this solution are equivalent to 0.05 grm. dextrose.

The urine is diluted exactly 10 or 20 times according to the amount of sugar present and placed in a burette. 10 c.c. of the standard solution are measured with a pipette into a porcelain basin, diluted with 40 to 50 c.c. water and heated to boiling. The solution is kept just boiling, and the diluted urine run in carefully with stirring, until the blue colour of the solution has just disappeared. From the volume of diluted urine required in the titration the amount of dextrose in grammes present in 100 c.c. of the original urine is calculated. Several determinations must be made. A flask heated on a water bath may be substituted for the basin in order to minimise the risk of oxidation of cuprous oxide.

Gerrard's Method.—The cyanide solution is prepared by adding cautiously an approximately 5 per cent. solution of potassium cyanide to 100 c.c. Fehling's solution diluted with 300 c.c. water, which is kept boiling, until the blue colour of the solution has just disappeared. The resulting liquid is cooled, diluted to exactly 500 c.c. and kept in a stoppered bottle.

For the titration 50 c.c. of the cyanide solution and 10 c.c. of standard Fehling's solution are measured into a basin or flask, and the diluted urine run in from a burette in exactly the same manner as in Fehling's method. The urine required in the titration contains 0.05 grm. dextrose.

Pavy's Method.—The standard solution contains 120 c.c. Fehling's solution and 300 c.c. strong ammonia per litre. 10 c.c. of this solution are equivalent to 0.05 grm. dextrose.

The nozzle of a burette is fitted to a small flask by means of a cork, through which is also passed a short bent tube to allow of the escape of steam and ammonia, when the flask is boiled. The urine is diluted exactly 10 to 50 times according to the amount of sugar present. The burette is filled with this diluted urine, care being taken that there are no bubbles in the nozzle. 10 c.c. Pavy's solution and about an equal volume of water are placed in the flask. The flask is now heated till it boils. The heating is continued and the urine allowed to drop in from the burette at such a rate that ebullition does not cease. When the colour in the flask is perceptibly less, the rate of addition of drops is much reduced, but is continued until all blue colour has disappeared. The first reading will be almost certainly too great, so that other determinations must be made. In the later determinations it is a good plan to run in fairly rapidly a quantity of urine, which will be almost but not quite sufficient, to wait till the colour is constant and then very carefully and slowly to add drops from the burette till the blue colour has quite disappeared. The amount of diluted urine employed should not be less than 2 c.c. or more than 5 c.c.

Normal human urine has an average reducing power equivalent to about 0·2 per cent. dextrose. Of this reducing power 18 per cent. is due to dextrose, 8 per cent. to uric acid (see p. 425), and 25 per cent. to creatinin (see p. 429), the remaining 50 per cent. being probably due to urochrome. Furthermore, the colour of urine renders the end-point of the titration much more uncertain than when a watery solution of dextrose is employed

When great accuracy is required, in order to remove all the urochrome as well as a considerable proportion (75 per cent.) of the uric acid and creatinin, Bang and Bohmannsson use blood charcoal and hydrochloric acid. We have obtained more constant results, however, by using acetone¹ and blood charcoal according to the following method:—

20 c.c. urine are mixed in a flask with 5 c.c. acetone and 2 gr. charcoal from blood (a teaspoonful). The flask is then shaken occasionally during five minutes, after which its contents are filtered through a dry filter paper into a test tube. Of the filtrate (which is always perfectly colourless) 5 c.c.² are used for Bang's titration, as described on page 293.

Sometimes the urine contains *pentose* (*i*-arabinose). In such cases it reduces but does not ferment with yeast; it gives Bial's test (p. 295).

The presence of *laevulose* is revealed by Seliwanoff's test (p. 278).

The Acetone Bodies in Urine.—These substances are:—

- (1) β -oxybutyric acid, $\text{CH}_3 \cdot \text{CHOH} \cdot \text{CH}_2 \cdot \text{COOH}$.
- (2) Aceto-acetic acid, $\text{CH}_3 \cdot \text{CO} \cdot \text{CH}_2 \cdot \text{COOH}$.
- (3) Acetone, $\text{CH}_3 \cdot \text{CO} \cdot \text{CH}_3$.

Aceto-acetic acid is an oxidation product of β -oxybutyric acid. Acetone is formed from aceto-acetic acid by the loss of carbon dioxide. A solution of aceto-acetic acid partially decomposes to acetone at ordinary temperatures. On boiling the decomposition becomes complete.

Acetone is present in minute traces in normal urine. All three bodies make their appearance in human urine when fat is being metabolised at an unusually rapid rate. They are present therefore in the urine of severe cases of diabetes, in the urine of starvation, and in the urine of many people when the carbohydrate of the diet

¹The acetone must be chemically pure, otherwise it may contain reducing substance.

²This amount of the filtrate is for a urine containing not more than 2 per cent. dextrose. If it contain less than 0·5 per cent. dextrose 10 c.c. of the filtrate should be taken. If it contain more than 2 per cent. 2·3 c.c. When, however, more than 2 or 3 per cent. dextrose is present the polariscopic method, or Bang's titration, without the addition of charcoal, will probably give close enough results for most purposes.

is reduced below 70 grm. per diem. Under these conditions the amount of the acetone bodies is increased by exercise.

EXPERIMENT X. Tests for Acetone. Legal's Test.—Add to the urine in a test tube a few drops of a fresh solution of sodium nitroprusside and then caustic soda solution till definitely alkaline. A permanent red colour develops, which becomes deeper and assumes a purplish tint on acidifying with strong acetic acid. (Compare with test for creatinin).

Rothera's Test.—Add a few drops of sodium nitroprusside solution, ammonia till alkaline, and saturate the liquid with ammonium sulphate crystals. A deep colour similar to that of permanganate develops and reaches its maximum in 15 minutes. This test is more sensitive and distinctive than Legal's.

Iodoform Test.—Distil a few c.c. of the urine with a few drops of dilute sulphuric acid. To the distillate add a few drops of iodine in potassium iodide solution and caustic soda till the iodine colour disappears. Iodoform is precipitated, and is detected by the characteristic smell.

EXPERIMENT XI. Test for Aceto-acetic Acid.—To the urine add ferric chloride solution in excess of that required to precipitate the phosphate present. A deep red colour in the solution indicates the presence of aceto-acetic acid. (Salicylic acid in the urine gives a very similar colour.)

There is no simple test for **oxybutyric acid**. The best procedure is based on Schaffer's method for estimating oxybutyric acid, in which this substance is oxidised to acetone. 50 to 100 c. c. urine which contains acetone is diluted with twice its volume of water, treated with basic lead acetate and ammonia (to remove possible glycuronic acid) and filtered. The filtrate is acidified with 10 c.c. sulphuric acid (conc.) and boiled for half an hour, with the addition of water to keep the volume constant; this removes the acetone present. It is then distilled (potassium bichromate 0.5 per cent. solution being added from a dropping funnel so as to keep the volume constant) as long as reduction occurs as shown by the colour. To the distillate are added a few c.c. of hydrogen peroxide (free from alcohol) and caustic soda till alkaline. It is then redistilled, and the second distillate tested for acetone by Rothera's test and by the iodoform test.

Homogentisic Acid is di-oxyphenyl-acetic acid $C_6H_3 \begin{matrix} \left\langle \begin{matrix} OH \\ OH \\ CH_2COOH. \end{matrix} \right.$

It reduces Fehling's solution. When present in the urine it causes the latter to become of a dark-brown colour on standing, or this change in colour may be hastened by adding some alkali. It is present in the urine throughout life, and it has been noticed that persons who exhibit it are almost invariably the children of first cousins. It can be easily

separated from the urine by adding a solution of lead acetate, filtering off the precipitate of inorganic salts which at first forms and allowing the filtrate to stand, when large needle-shaped glancing crystals of the lead salt separate out. If these be collected and treated with sulphuretted hydrogen, so as to remove the lead, the acid is obtained in a pure state.

Glycuronic Acid.—Chemically this is dextrose in which the end— CH_2OH —group has become oxidised to form COOH , or carboxyl. It has, accordingly, the formula $\text{COOH}-(\text{CH.OH})_4-\text{CHO}$. It is an intermediate body in the metabolism of dextrose, and usually becomes further decomposed in the organism, to yield carbon dioxide and water. Sometimes, however, it unites with the aromatic bodies (plenol, skatol, etc.) absorbed from the intestine to form a salt. In this combination it takes the place of sulphuric acid (see p. 435). In very small amount, it seems to be always present in the urine, but under certain conditions (as after the administration of certain drugs) it becomes increased to such an extent as to impart to the urine a very considerable power of reducing metallic oxides in alkaline solution. When this is the case it is apt to be confused with dextrose. The only absolute test whereby it may be distinguished from dextrose is that it does not ferment with yeast. It gives the pentose reactions.

CHAPTER XXI.

LACTIC ACID, ITS ESTIMATION AND SIGNIFICANCE.

By J. H. RYFFEL, M.A., B.Sc., Demonstrator of Physiology, Guy's Hospital.

THE lactic acid of the body, called sarcolactic acid, is the dextrorotatory variety, the free acid rotating the plane of polarisation of polarised light to the right, while its metallic salts rotate to the left. The specific rotatory power of the zinc salt $[\alpha]_D$ (see p. 354) is -7.5° to -6.5° according to the strength of the solution. The zinc salt contains two molecules of water of crystallisation, whilst that of the inactive or fermentation lactic acid contains three molecules.

Identification and Estimation of Lactic Acid. Ether Extraction Method.—If the material is blood or tissue, it is extracted with alcohol or with boiling water; if urine, it is concentrated and extracted with alcohol.

The extract is evaporated to small bulk, acidified with phosphoric acid, and extracted repeatedly by shaking in a funnel with many times its volume of ether. The residue after the evaporation of the ether extract is dissolved in water, boiled with zinc carbonate, filtered and evaporated. Crystals of the zinc lactate are thus obtained, which are weighed either after drying in air, when they contain their water of crystallisation, or after complete drying at 110°C . The product is liable to be impure. This is partly obviated by washing the crystals with alcohol. Frequently the aqueous solution obtained after ether extraction is treated with lead carbonate, filtered, treated with hydrogen sulphide to remove lead, and again extracted, but this procedure involves loss. In any case the percentage of zinc in the zinc salt must be determined in order to prove its identity as zinc lactate.

The method, though cumbersome, is sufficiently satisfactory when relatively large amounts of lactic acid are present, but, when the amount of lactic acid is small, the zinc lactate is almost certain to be impure, especially if the determination is made on urine. Moreover, in the extraction of lactic acid from a watery solution by means of ether there is always some loss, due to incomplete extraction and to oxidation of lactic acid by impurities in the ether. When the amount of lactic acid is small, this loss is relatively very considerable.

The Thiophene Test for lactic acid introduced by Hopkins has already been described (see p. 354). It is very sensitive and is distinctive for a hydroxy acids, but cannot be used quantitatively and is difficult to apply to urine.

The Distillation Method.—This method depends on the fact that lactic acid, when heated above 140°C . with sulphuric acid, yields acetaldehyde quantitatively according to the following equation:

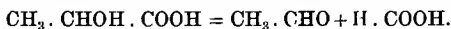

40 c.c. of the liquid, which must be free from sugar and nearly free from protein, are placed in a 500 c.c. Jena distillation flask. 45 c.c. pure sulphuric acid are rapidly added from a dropping funnel, the flask being shaken and cooled under the tap. The flask is then fitted with a rubber cork carrying an inlet tube for steam and a thermometer, so arranged that both dip well below the surface of the liquid. It is then placed in a slanting position on wire gauze on a retort stand and attached to a good vertical condenser. (For this purpose the exit tube of the flask must be bent at a suitable angle.) A flask of about 300 c.c. capacity, immersed in cold water, is placed as the receiver of the condenser with its mouth just touching the jacket of the condenser, so as to prevent loss of aldehyde by evaporation. A gentle current of steam from an ordinary steam generator is then passed into the distillation flask, which is vigorously heated with a Bunsen burner. Distillation will generally begin at about 140°C ., but the heating is continued till the temperature reaches 155°C ., when the current of steam is increased, and the heat applied to the flask adjusted so that the temperature is kept between 153° and 157°C . When about 100 c.c. have collected in the receiver, or the distillation has lasted nearly 30 minutes, the decomposition is complete. The contents of the receiver are rendered just permanently alkaline by the addition of 2 per cent. caustic soda solution and a little litmus solution, diluted to about 150 c.c., and redistilled into a flask with a 100 c.c. mark in the neck, using the same precautions to prevent loss as before, until about 50 c.c. have

been collected. (When the amount of lactic acid is excessively small, as is the case in normal urine, a 50 c.c. flask may be employed, the quantities given in what follows being halved.)

To the second distillate are added 0.5 c.c. Schiff's reagent (see later) and water to bring the volume to 100 c.c. The flask is stoppered, inverted a few times to mix its contents, placed in a glass vessel containing water at 15° C., and left for 30 minutes in diffuse daylight. The Schiff's reagent reacts with the aldehyde present, giving a red colour, which reaches a maximum in 30 minutes and then slowly fades. This reaction may be used qualitatively as a test for lactic acid. For quantitative estimation the coloured liquid (α) is transferred at the end of 30 minutes to one tube of a colorimeter. A convenient depth of liquid is selected. The two formaldehyde standards (see later) are selected which are nearest to α in colour, and the depth of each determined which gives the same intensity of colour as the selected depth of α .

The calculation is best described by an example.

	Formaldehyde 4 c.c.	α	Formaldehyde 8 c.c.
Readings of equal depth of colour,	2.42 cm.	2 cm.	1.46 cm.
10 ÷ readings,	4.13	5	6.85

$$\text{Then } \alpha \text{ is equivalent to } 3 \text{ c.c.} + \frac{5 - 4.13}{6.85 - 4.13} = 3.32 \text{ c.c. standard formaldehyde solution.}$$

The amount of lactic acid in the liquid originally employed =

$$\frac{3.32 \times 3.435 \times n}{0.4} \text{ mg.}$$

where n is the standard value of the formaldehyde.

If the colour of α is much greater than that of any of the standards, another determination must be made, using a more dilute solution of lactic acid.

The Formaldehyde Standards.—A series of four stoppered flasks is prepared containing 0.5 c.c. Schiff's reagent and 1.5 c.c., 2 c.c., 3 c.c., 5 c.c. respectively of dilute standard formaldehyde solution, made up to 100 c.c. with water. These are placed in a dark cupboard till required. The colour develops very slowly, and is fairly permanent, so that the standards may be used any time within three days after the first twelve hours.

The dilute standard Formaldehyde Solution.—10 c.c. commercial formalin (40 per cent. formaldehyde) are diluted to 100 c.c. This solution will keep practically indefinitely. To make the dilute standard solution 5 c.c. of this solution are diluted to 500 c.c. This dilute solution will keep practically unaltered for a week if well stoppered. It is standardised, unless made from an already standardised formaldehyde solution, by the following method: 40 c.c. are measured into a stoppered bottle, 25 c.c. $\frac{N}{10}$ iodine solution are added, and then 10 per cent. caustic soda, till the liquid assumes a light yellow colour. The mixture after standing for 10 minutes is acidified with dilute hydrochloric acid and titrated with $\frac{N}{10}$ sodium thiosulphate solution, until the colour of the iodine just disappears. The volume in c.c. of thiosulphate solution required is subtracted from 25 c.c. Let the remainder = b c.c. Then the formaldehyde in mg. present in 1 c.c. of the solution = $n = \frac{1.49 \times b}{40}$.

The value of n should be nearly 0.4 mg.

Schiff's Reagent.—1 grm. finely powdered rosaniline hydrochloride and 100 c.c. water are placed in a small bottle with a closely fitting stopper. Sulphur dioxide is passed in from a syphon, till the dye just dissolves to a yellow solution, when the liquid is very nearly saturated with the gas. The reagent loses sulphur dioxide rather readily, so that it must be kept closely stoppered, and must be resaturated occasionally with sulphur dioxide. The formaldehyde standard with 0.5 c.c. of the reagent and 5 c.c. dilute formaldehyde solution (2 mg. formaldehyde) made up to 100 c.c. with water should be of such a depth of colour, that by the colorimeter 1.3 to 1.7 cm. is equivalent in colour to 0.7 cm.

$\frac{N}{100}$ potassium permanganate.

The method can be applied to urine either directly, or after rendering alkaline with sodium carbonate and evaporating on the water bath, but not more than 40 c.c. of urine of specific gravity 1020 should be employed for one distillation in either case, as with more urine frothing is liable to occur.

Glycuronic acid forms a source of error, but may be removed by means of basic lead acetate. For this purpose 25 to 200 c.c. urine are measured into a 500 c.c. graduated flask. Slight excess of basic lead acetate solution, 10 c.c. strong ammonia and water to make 500 c.c. are added. The contents of the flask are well mixed, allowed to stand for a short time and filtered through a dry filter into a dry flask. A measured volume of the filtrate (350 c.c. or less) is evaporated in a dish on the water bath, sodium carbonate solution being added to keep the liquid alkaline. The residue in the dish is then washed into the distillation flask with 40 c.c. water and 45 c.c. sulphuric acid and treated as above. This treatment causes a small loss of lactic acid, so that only about 50 per cent. of minute quantities of lactic acid added to urine are recovered. When the quantity of lactic acid is considerable, however, the loss is negligible.

In order to apply the method to blood the following preliminary procedure is necessary. The blood, of which 20 c.c. is usually quite sufficient, is diluted about five times, heated to boiling in order to coagulate the proteins, and filtered. The coagulum is very thoroughly washed with boiling, faintly acidulated water. The total liquid thus obtained is rendered alkaline with sodium carbonate, evaporated and employed for the determination.

Lactic acid has been found in all tissues, but the amount present depends on the condition of the tissue and on the method employed for killing it. Muscle, for instance, forms lactic acid during the onset of rigor. Lactic acid appears to be a normal constituent of blood, but its amount is variable. In the venous blood of man at rest its amount varies between 10 mg. and 20 mg. per 100 c.c., but the arterial blood of animals, particularly rabbits, shows higher values up to 100 mg. per 100 c.c.

By the ether extraction method lactic acid has never been found in normal urine, but this does not preclude its presence in small quantity. By the distillation method, however, lactic acid is always present in urine, amounting in man on an ordinary diet to about 4 mg. per hour during the day and 2 mg. at night when determined directly, or to about half this quantity when determined after lead acetate treatment.

Lactic acid is, therefore, present in relatively greater amount in the blood than in the urine under ordinary conditions, being to a considerable extent kept back by the kidneys.

When, however, lactic acid in the blood rises above a limiting value, which in man is less than 70 mg. per 100 c.c., it is actively excreted by the kidneys, so that the urine may often contain 500 mg. per 100 c.c. even when fairly dilute. This result is in man easily brought about by violent exercise such as running.

EXPERIMENT I. Collect the urine of a man at rest, or engaged in quiet work, during half an hour, and determine the lactic acid in the urine by the distillation method. Then let him run for at least two minutes at a pace sufficient to produce marked dyspnoea. Collect and measure the urine after half an hour. Determine the lactic acid in 20 c.c. of this urine. A qualitative determination is sufficient, as the reaction obtained with the urine passed at rest is very small. The urine passed at rest will not give the thiophene test. That passed after the exercise will give the test after the following preliminary treatment. The urine is rendered alkaline with sodium carbonate, evaporated and extracted with alcohol. The alcohol is evaporated and the residue dissolved in a little water, strongly acidified with phosphoric acid and extracted with many times its volume of washed ether in a separating funnel. The ether is separated and shaken up with dilute sodium carbonate solution, again separated and used for extracting the acid liquid a second time. This process is repeated two or three times. The alkaline liquid so obtained is boiled with animal charcoal till colourless, filtered, and evaporated to dryness. The residue is then dissolved in 5 to 10 c.c. pure sulphuric acid and the thiophene test applied. In spite of boiling with charcoal a reddish brown colour is usually obtained on adding the sulphuric acid, which masks the reaction to a certain extent.

Violent exercise also increases the acidity of the urine (see p. 431) and the proportion of ammonia nitrogen to the total nitrogen. The amount of lactic acid in the blood is increased, and the alkalinity of the blood reduced at the end of a short period of violent exercise, but both have returned practically to normal at the end of half an hour.

When more moderate exercise is taken, such as walking, there is no increase in the lactic acid of the urine, even if the exercise be continued for many hours, so that the production of lactic acid in exercise clearly depends on the intensity of the muscular activity. There is no evidence that the blood is less well supplied with oxygen than usual during a short period of violent exercise, so that the muscles are presumably not short of oxygen. The production of an increased

quantity of lactic by the muscles, which thus passes into the blood, is, therefore, a direct result of great muscular activity.

This increased production of lactic acid serves a very useful purpose in making the blood more acid, and so stimulating the respiratory centre, and probably the heart also. The increase of pulse rate, blood pressure and respiration produced by violent exercise are matters of common observation. Although the output of carbon dioxide is much increased, the alveolar carbon dioxide (see p. 197) is not high, except for a short time after the start, and falls markedly below the normal level for about half an hour after the period of violent exercise, so that the increased respiration cannot be due to carbon dioxide alone. If, however, we suppose that the activity of the respiratory centre is always regulated by the acidity of the blood, which depends on the amounts of carbonic and other acids present, we see how lactic acid may take the place of carbon dioxide in increasing the activity of the respiratory centre.

Experimentally in animals the urinary output of lactic acid may be greatly increased by reducing the supply of oxygen, or by carbon monoxide poisoning. The experiment has to be continued for several hours with the animal in the collapse stage of asphyxia. In man increased lactic acid excretion has occurred from long-continued accidental carbon monoxide poisoning, but not as yet from voluntary shortage of oxygen. Shortage of oxygen is not, therefore, as efficient a cause of increased production of lactic acid as muscular activity, although respiration is increased and the alveolar carbon dioxide much reduced even in short experiments on man. It may be that in this case the respiratory centre is the first to feel the lack of oxygen, and is stimulated by lactic acid, which it itself produces, instead of by the acidity of the general blood stream.

The results of the experiments of Fletcher and Hopkins on surviving frogs' muscles are in general agreement with the above results from man. These observers showed that the muscles of frogs at rest contain very little lactic acid, provided the muscles are killed with a minimum amount of stimulation. For this purpose they cooled the hind limbs with ice, then rapidly separated the muscles and ground them up with ice-cold alcohol and sand. The lactic acid was isolated as anhydrous zinc lactate after ether extraction. Resting fresh muscle gave 0.03 to 0.045 per cent. zinc lactate. When the muscle was tetanised the lactic acid rose, until when irritability was lost by fatigue the yield of zinc lactate was about 0.2 per cent. If the muscle was then kept in oxygen, the irritability returned and the zinc lactate fell to about 0.1 per cent. Oxygen inhibited, but did not entirely prevent, the onset of

fatigue and production of lactic acid, and enabled the muscle at rest to remove preformed lactic acid. Irritation or injury of the muscle in any way increased the lactic acid in it. The production of heat rigor in the muscle gave the maximal yield of lactic acid, from 0.4 to 0.5 per cent. zinc lactate according to the time of year. This yield of lactic acid was independent of the previous manipulation, tetanisation, etc., to which the muscle had been subjected.

CHAPTER XXII.

HAEMOLYSIS AND PRECIPITINS.

A RED blood corpuscle or erythrocyte is usually regarded as consisting of an envelope enclosing haemoglobin and salts of various inorganic bases, of which potassium is predominant in some animals, sodium in others. The interior of the corpuscle is also believed by some to contain a meshwork connected with the envelope and of similar structure. The envelope and meshwork are composed chemically of lipid substance and protein, and behave physically as a semi-permeable membrane, readily allowing small molecules (such as those of water) to diffuse through but not so readily larger ones, such as those of many inorganic salts.

Within the envelope the haemoglobin cannot be present in ordinary solution for its concentration is greater than that of a saturated solution of haemoglobin in water or saline solution. The red corpuscle is developed from a cell, but in its metamorphosis most of the cellular properties become lost, the greater part of the protein constituents of the cell changing into haemoglobin.

In the following experiments some evidence will be obtained to show:—
1. That the envelope is semi-permeable; 2. That it possesses certain qualities common to it and other cells; 3. That lipid substance is an important constituent of the envelope.

It is comparatively easy to study alterations in the permeability of the corpuscular envelope, because, when haemoglobin leaves the corpuscle and passes into the fluid surrounding the corpuscle, this fluid becomes tinged with red: laking or haemolysis is said to have occurred.

EXPERIMENTS DEPENDING ON THE FACT THAT THE CORPUSCULAR ENVELOPE IS SEMI-PERMEABLE IN NATURE.

EXPERIMENT I. Examine some blood under the microscope (frog's blood is very suitable because of the large size of the corpuscles). Allow some water to run under the cover slip, and at the interface between blood and water note the rapid swelling of the corpuscles followed by their rupture. To another preparation add a 2 per cent. solution of sodium chloride and note that the corpuscles shrink and become irregular in shape. The explanation

of these results is that the envelope readily allows water to pass through it but not inorganic salts. The water tends to pass into the corpuscle in the first part of the experiment because the osmotic pressure inside the corpuscle is higher than that outside. To equalise this difference of osmotic pressure water passes in but salts cannot pass out because the membrane is impermeable towards them. The shrinkage of the corpuscle in the second part of the experiment bears out this explanation.

EXPERIMENT II. *Determine what strength of NaCl solution just prevents haemolysis.* Into each of a series of test tubes place 20 c.c. of sodium chloride solutions of gradually increasing concentration, e.g. 0.5 per cent., 0.55 per cent., 0.60 per cent., 0.65 per cent., 0.70 per cent.¹ To each tube add five drops of fresh defibrinated (ox or dog) blood; mix by inverting the tube and allow to stand for some minutes. It will be noted that the supernatant fluid in the case of the stronger solutions is colourless, but that in the tube with 0.55 per cent. NaCl it is slightly tinted red, indicating that the corpuscular envelope has ruptured and the haemoglobin has escaped. The saline solution which just prevents haemolysis stands somewhere between 0.55 and 0.6 per cent. in strength.

By estimating the osmotic pressure of blood serum and of the above saline solutions, either by means of the depression of freezing point method or by the microscope or haematocrit (see Exp. IV.), it will be found, however, that a 0.55 per cent. saline solution has a much lower osmotic pressure than that of blood serum (which equals a 0.9 per cent. NaCl solution). The results of the above experiment therefore show us that the corpuscular envelope can withstand a certain amount of hypotonicity before it ruptures.

If the experiment be repeated with other salts than sodium chloride it will be found that the strength of solution which just fails to show haemolysis bears a close relationship to the molecular weight of the salt used, i.e. the corpuscular envelope gives way at corresponding osmotic pressures. There are certain salts, however, for which this is not true; the most important of these are the ammonium salts and organic substances containing an ammonium residue, e.g. urea, others are sodium carbonate, glycerine, etc.

EXPERIMENT III. Mix 5 drops of ox blood with 20 c.c. of a 0.7 per cent. solution of ammonium chloride. Laking will occur although this strength of solution has a higher osmotic pressure than a 0.55 per cent. solution of sodium chloride.

We can determine the osmotic pressure of a saline solution indirectly by observing what effect it has on the volume of red blood corpuscles. When no change in volume occurs with a given solution this must be isotonic with the blood serum; if it causes swelling it is hypotonic, if shrinkage, hypertonic. Besides employing the microscope to detect these changes in volume, we may employ an instrument called a *haematocrit*.

EXPERIMENT IV. The haematocrit consists of two capillary glass tubes, graduated in one hundred equal parts; the upper ends are widened so as to

¹ These solutions of NaCl are best prepared in the following manner: Fill one burette with a 1 per cent. NaCl solution and another with distilled water. Into test tube 1 place 5 c.c. of the NaCl solution and 5 c.c. of water (= 5 per cent.); into test tube 2 place 5.5 c.c. NaCl solution and 4.5 c.c. water (= 0.55 per cent.), and so on for the other tubes.

make a mixing chamber. By attaching a piece of indiarubber tubing to the tube, blood is sucked up to the mark 100, clotting being retarded by first of all drawing some cedar oil through the tubes. The tubes are then placed in a holder, the ends being closed by small metal plates held in position by a spring, and rotated on a centrifuge until the corpuscles have been thrown down to a certain mark, which is then noted. After cleaning, blood from the same source is again sucked up to the mark 100 and then an equal volume of some solution. The two are thoroughly mixed in the mixing chamber by means of a fine wire and the instrument again rotated. If the solution is isotonic with the blood serum the corpuscles will stand at the same level as before, if it be hypotonic they will stand at a higher level, if hypertonic, at a lower. It will be seen that by this method we can readily ascertain, in a series of solutions of unknown osmotic pressures, whether one of them is isotonic with the blood serum.

The haemoglobin may also be caused to leave the corpuscle by bringing about an alteration in the permeability of the envelope. Such an alteration may be brought about in a variety of ways, some of which may be styled *physical*, such as heating, freezing or shaking the blood; others, as purely *chemical*, such as the addition of ether and other fat solvents, saponin, bile salts, acids and alkalies; and others as *bio-chemical*, such as the addition of immune serum.

In the present state of our knowledge it is impossible to say in every case definitely what the alteration in permeability is due to, but some very important facts are known.

Physical Laking. EXPERIMENT V. 1. Place some blood in a test tube and keep at 60° C. for a few minutes. The blood becomes laked.

2. Repeatedly freeze and thaw some blood and then dilute with some isotonic saline. Note the evidence of laking.

Chemical Laking.

3. Place some blood in four test tubes; to one add some ether, to another some 3 per cent. saponin solution, to a third a solution of sodium taurocholate in isotonic saline, and to the fourth some acetic acid. Laking occurs in all cases.

4. To another test tube containing 1 c.c. of blood add 3 c.c. of a 2 per cent. solution of urea. Laking soon occurs. Since this strength of urea solution has practically the same osmotic pressure as .9 per cent. NaCl, it is of further interest to see whether its laking influence is due to its having, like the above-mentioned chemicals, a damaging effect on the corpuscular envelope. This question can be settled by repeating the above experiment with a solution of 0.9 per cent. NaCl containing 2 per cent. of urea. It will be found that no laking occurs thus showing that, unlike bile salts and saponin, the urea does not damage the envelope. The reason why laking occurs with the pure urea solution must therefore be that the urea molecule penetrates the corpuscular envelope very readily, perhaps as readily as water itself does.

A considerable amount of work has been done on *saponin laking*, the most important outcome of which has been to show that the haemolytic effect of this drug can be antidoted by something (probably lecithin or cholesterol) contained in normal blood serum. To demonstrate this effect it is of course

first of all necessary to take blood corpuscles that have been washed free of adherent serum.¹

5. *Determine the minimum amount of a 0.3 per cent. saponin solution necessary to produce laking of washed dog's corpuscles in five minutes at room temperature.*

Label four test tubes *A, B, C, D*, and place in each 2 c.c. of 10 per cent. dilution of dog's washed blood corpuscles in 0.9 per cent. NaCl solution. Of a 0.3 per cent. solution of saponin in 0.9 per cent. NaCl solution, add to *A* 0.05 c.c.; to *B* 0.1 c.c.; to *C* 0.15 c.c.; to *D* 0.2 c.c. Immediately fill each test tube with 0.9 NaCl solution and without shaking allow to stand for five minutes. Then note the tube which just shows complete laking. Repeat the observation taking amounts of saponin in 1/100th of a c.c. between the amounts in the previous trial, which did and which did not show laking (*i.e.* suppose trial gave laking with 0.15 c.c. but not with 0.10, then in this experiment use 0.11 c.c. saponin in *A*; 0.12 c.c. in *B*, and so on).

6. *Demonstrate the antidotal effect of blood serum on saponin laking.* Place 2 c.c. of a 10 per cent. suspension of dog's washed blood corpuscles in four marked test tubes: add to each 2 c.c. of dog's blood serum and mix. Then add minimal laking amount of saponin solution (determined as in Experiment 5) to *A* and to the others amounts increasing by 0.05 c.c. Fill up the test tubes with 0.9 per cent. sodium chloride solution and, after standing for five minutes, see in which tube laking has occurred. The antidotal effect of the blood serum will be clearly shown.

There are some very peculiar differences between the action of laking agents. Thus saponin evidently acts on some constituent of the envelope which is closely related to cholesterol (or lecithin), for if a saponin solution be shaken with cholesterol its haemolysing effect will become greatly reduced. In its action on the corpuscular envelope the saponin either dissolves the cholesterol or forms a compound with it which is soluble in the surrounding fluid, and in this way makes the envelope so permeable that the haemoglobin escapes. It is of interest, in this connection, to note that if the mixture of blood and saponin be examined under the microscope, the corpuscle will be seen to swell somewhat before haemolysis occurs, showing that its permeability towards water is first of all lowered. The electrical conductivity increases somewhat during laking by a minimal dose of saponin, probably due to the escape of haemoglobin, but if at this stage more saponin be added, the electrical conductivity still further increases, showing probably that some compound of stroma and inorganic salts has been broken down (Stewart). With bile salts, on the other hand, there is no preliminary swelling of the corpuscles; their haemoglobin contents are set free immediately. Ether does not merely act by dissolving out lipid, for ether saturated with cholesterol or with the lipid substances of corpuscles themselves still causes laking.

Bio-chemical Laking.

Perhaps the most interesting haemolytic bodies are those which become

¹To wash blood corpuscles free of adherent serum a good centrifuge is necessary. The defibrinated blood is first of all centrifuged and the serum removed with a pipette. The centrifuge tube is then filled up with 0.9 per cent. sodium chloride solution and, after shaking, placed in the centrifuge. This process is repeated at least three times and, for more particular work, even more.

developed in the tissue fluids of an animal when the defibrinated blood of an animal of another species is repeatedly inoculated into it. These haemolysins belong to the general group of anti-bodies in which are included the antitoxins, precipitins, agglutinins, bacteriolysins, etc. Haemolysins also sometimes occur as normal constituents of tissue fluids and secretions; for example, they are present in snake venom.

A particular study of these anti-bodies is more properly a bacteriological than a bio-chemical one, but a study of a few of their essential properties must also be included in the course in bio-chemistry, since many ferments seem to act according to the same laws as those which govern the action of haemolysins.

Haemolysins.—The washed erythrocytes of the rabbit are laked when mixed with the blood serum of the dog or ox. This haemolytic effect of dog's blood serum becomes much more marked, however, if the dog be previously inoculated with defibrinated rabbit's blood.¹ Besides causing haemolysis, the serum usually causes the corpuscles to run together into clumps. This process is called *agglutination*, and when it occurs in blood the corpuscles settle down and can be filtered off.

EXPERIMENT VI. (1) Examine microscopically (under cover slip) the effect of dog's serum on rabbit's erythrocytes. (Agglutination, then haemolysis.)

(2) With a 5 per cent. suspension of *washed rabbit's erythrocytes* in physiological saline perform the following experiments, ascertaining the degree of haemolysis by allowing the corpuscles to settle, and noting the intensity of colour of the supernatant fluid. Note also any *agglutination*.

In small short test tubes, mix :

- | | | | | | |
|----|--------|----------------|----------|-----------------|------------|
| A. | 1 c.c. | suspension and | 0.5 c.c. | 0.9% NaCl | (control). |
| B. | 1 c.c. | „ | 0.2 c.c. | immunised dog's | serum. |
| C. | 1 c.c. | „ | 0.5 c.c. | „ | „ |

Place the tubes in the water-bath at 40° C., and observe after fifteen minutes.

The haemolysin thus produced by inoculation of foreign blood can be shown to consist of two parts, one of which is destroyed by moderate heat (the thermo-labile body), the other being much more resistant in this particular (the thermo-stable body). The thermo-labile body is not specific in its nature, but is a normal constituent of blood serum; it is usually called the *complément* or *alexine*. By specific in this connection is meant that the substance is not confined in its action to one kind of corpuscle. The thermo-stable body is specific in nature, being produced as a result of the inoculation of foreign blood and acting only when brought in contact with blood corpuscles which are of the same kind or are very closely related to those of the blood used for inoculation. On account of analogy between the thermo-stable body and anti-bodies in general it is often called the *immune body*.

EXPERIMENT VII. Place 3 c.c. of immunised dog's serum in the water-bath at *exactly* 50° C. for ten minutes. Allow to cool. Repeat the above experiments, A, B, and C, using the heated serum: no haemolysis will occur, the heating

¹ One intraperitoneal injection of 50 c.c. of rabbit's defibrinated blood will render the dog's serum strongly haemolytic in about four days after the injection. If the injection be repeated once a week for three or four weeks the haemolytic power will be very strong. When an animal is inoculated in this way it is said to be immunised. An equally suitable pair of animals is the rabbit and guinea pig, but the amount of serum obtainable is small.

having destroyed something necessary for haemolysis. Is there any agglutination? Now add 1 c.c. *rabbit's serum* to some of the mixture of previously heated serum and blood corpuscles; haemolysis will occur. To another part add some serum from an uninoculated (normal) dog. The same result will be obtained.

The destruction of the complement by heating is called *inactivation*. That inactivation destroys something which, though necessary for haemolysis, is yet a normal constituent of serum, is shown in the above experiment by the fact that reactivation of the haemolysin can be effected by addition of *rabbit's serum*; i.e. of the same serum that the erythrocytes are normally accustomed to.

The complement, whatever its chemical nature may be, is a constant constituent of serum, but under normal conditions it does not as a rule act on the erythrocytes and cause haemolysis because of the absence of the immune body. To produce the immune body, inoculation with foreign blood is usually necessary. There are in general two views as to the mechanism by which these two constituents of serum act in bringing about haemolysis. The French school believe (with Bordet) that the immune body acts on the corpuscle as a mordant acts on cotton in dyeing; in other words, it sensitises the corpuscle towards the complement (thus, the French call it the *substance sensibilatrice*). The German school (headed by Ehrlich), on the other hand, believe that the immune body first of all combines with the corpuscle, and that the complement then combines with the attached immune body and acts through it on the corpuscle.

It would be out of place here to give a detailed account of the experiments that have been brought forward in support of these hypotheses, but one important fact can be easily demonstrated, viz. that the immune body readily unites with the corpuscle in the absence of the complement, and that the subsequent addition of complement then causes haemolysis.

EXPERIMENT VIII. Centrifugalise 5 c.c. of a suspension of washed rabbit's erythrocytes, and then carefully remove as much of the supernatant fluid as possible. This yields, as sediment, erythrocytes that are free of complement. Now add to the erythrocytes 2 c.c. of inactivated serum from an immunised dog; shake the tube to obtain complete mixing, and allow to stand for some minutes. No laking occurs. Then fill up the tube with 0.9 per cent. sodium chloride and centrifugalise. Pipette off the supernatant fluid and repeat the washing three times, so as to remove all traces of the inactivated serum, which may be merely adherent to but not combined with the corpuscles. Now add some normal serum to the tube and warm to 38° C.: haemolysis occurs, the complement in the normal serum having acted on the erythrocyte-immune body compound.

The immune body acts, therefore, as a link uniting corpuscles with complement. It may be considered to possess two combining groups, and is hence called an *amboceptor*. One of these groups—called the cytophilic group—first of all unites with a side chain of the erythrocyte, and then the other group—called the complementophilic—unites with the complement, resulting in destruction of the erythrocyte. That the reaction takes place in this order is demonstrated in the following experiment:

EXPERIMENT IX. Centrifugalise 5 c.c. of the above suspension of rabbits' erythrocytes, and with a pipette remove as much of the supernatant fluid as possible. Place the sediment in a test tube, and cool in crushed ice to zero. In another test tube likewise cool 0.5 c.c. of immunised dog serum. Mix the cooled corpuscles and serum, and keep them at 0° for one hour, after which transfer the mixture to a cooled centrifuge tube, and immediately centrifugalise. Then remove

the supernatant fluid carefully, and test it and the sediment for the presence of amboceptor and complement in the following manner :

a. Add 0·2 c.c. of the supernatant fluid to 0·5 c.c. of the 5 per cent. suspension of the washed erythrocytes of the rabbit, and incubate at 40° for ten minutes. No laking will probably be noted. Now add a few drops of *inactivated* immunised dog's serum (see Experiment VII.), and incubate; laking will probably occur. The conclusion is that the supernatant fluid contained complement, but no amboceptor. If the experiment is unsuccessful it must be repeated again, using a smaller amount of the supernatant fluid.

b. Shake the sediment with a few c.c. of ice cold 0·9 per cent. sodium chloride solution, and centrifugalise. Remove the supernatant fluid with a pipette and place some of the washed sediment to a small test tube, and incubate; only slight laking, if any, will be noted in ten minutes. Now add a few drops of *rabbit* serum or some of the supernatant fluid used in *a*, when laking will become marked. The conclusion is that the amboceptors had combined with the erythrocytes, but not with the complement.

Precipitins.—Not only cells and toxins, but proteins also, react in the manner above described. The reaction manifests itself in the formation of a precipitate. For example, the serum of one animal can cause the serum protein of another animal to become precipitated, indicating that it contains some body which changes the nature of the protein so as to render it insoluble. It is called a precipitin, and, like anti-bodies in general, *e.g.* haemolysins, it seems greatly increased in amount by inoculation. Thus, if rabbit serum be mixed with ox serum the mixture remains clear, or only becomes slightly cloudy. If, however, ox serum be injected intraperitoneally or intravenously into a rabbit, and the inoculation repeated every three or four days for some weeks, then the rabbit serum will, when mixed with ox serum, cause a marked precipitation of the proteins. A precipitin has become developed by inoculation. Precipitins are remarkably specific in nature, so that if a series of rabbits be inoculated as above described, each with the blood serum of some different animal, there will be produced in the serum of each rabbit a precipitin which reacts only with the serum of the same kind of animal whose blood was used for inoculation, or with that of some closely allied species.

In this way a variety of sera can be prepared (and preserved in sealed tubes), which are peculiarly delicate and specific reagents for the detection of the proteins used to produce precipitins in them. By an application of these facts it is possible to distinguish from what animal a given blood serum (or blood solution) has been obtained. Thus, if it be desired to ascertain whether a blood stain is of human blood, it is dissolved in water and filtered till clear, and then mixed in a small test tube with a few drops of the serum of a rabbit that has been inoculated for some time with human blood. If a precipitate occurs the inference is that the stain was of human blood. It is impossible to cause precipitin formation by inoculation with blood from another animal of the same kind or from one that is closely related. Thus, no precipitin will be developed in a rabbit serum by inoculating the rabbit with guinea pig's serum. For the same reason, the bloods of closely related animals can form precipitins that are common to them all. Thus, if the blood of certain monkeys be inoculated in rabbits, the serum of the rabbit will give the precipitin reaction not only with monkey's blood, but also with that of man.

CHAPTER XXIII.

THE PIGMENTS OF URINE.

WHEN fresh normal urine is examined by means of the spectroscope it usually presents no absorption bands, a diffuse absorption of the violet end being alone conspicuous.

The yellow colour of the urine is to be regarded as due almost entirely to the presence of a preformed pigment, **urochrome**. If this pigment be removed from the urine, the colour of the urine is largely lost. It may be separated from urine by saturating urine with ammonium sulphate and filtering. The filtrate which contains the pigment is shaken with alcohol, and by such repeated extractions from the saline solution practically all the pigment may be removed. The urochrome may now be precipitated by adding an excess of ether. The substance is readily soluble in water and when examined by the spectroscope shows no absorption bands.

Urobilin is present in very small quantities in normal urine and the amount normally present is generally in the condition of a chromogen. In abnormal conditions the urine may tend to have a brownish tint added to the ordinary rich orange colour and such urine frequently contains urobilin. A solution of urobilin or urine rich in urobilin will present the spectrum shown in Fig. 256, 1. If a concentrated solution of urobilin in sodium hydrate be taken and hydrochloric be added till the mixture is slightly acid, a turbid condition of the liquid results owing to imperfect re-resolution of the pigment in the acid. Examined spectroscopically a band is seen in the position of the E-line, in addition to the normal band at the junction of the green and blue (Fig. 256, 2). If the liquid be filtered the E-band will be no longer seen.

As regards the connection of urobilin and urochrome, it is important to remember that when urochrome is acted upon by aldehyde a urobilin-like substance is produced, and if urobilin be oxidised with potassium permanganate a substance similar to urochrome is formed.

The pink colour possessed by a deposit of urates is due to another pigment **uroerythrin**. This pigment is never excreted in large amount, but it possesses in high degree a colouring power. If a pink urate deposit be dissolved in warm water the urates may be precipitated by saturation with ammonium chloride carrying down the pigment. This may now be extracted with alcohol, and on shaking the alcoholic solution with chloroform to which one drop of acetic acid has been

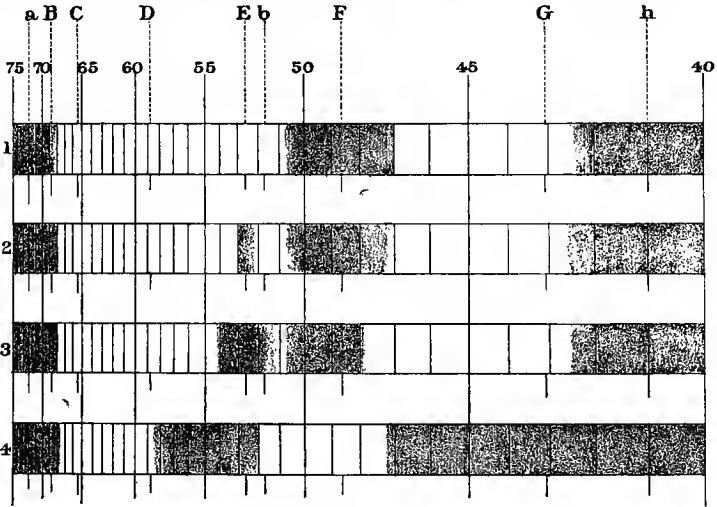

FIG. 256.

1. Acid urobilin in strong solution.
2. Urobilin precipitated by acid from its alkaline solution and partially redissolved. The so-called E-band spectrum.
3. Uroerythrin.
4. Uroerythrin in pink urates sediments.

added the pigment passes into the chloroform. It now gives the spectrum seen in Fig. 256, 3. If the pink urate deposit be simply dissolved in warm water the spectroscopic appearance is different, as represented by Fig. 256, 4.

Haematoporphyrin is normally present in very small amount in urine. After certain drugs it may be present in comparatively large amounts. Even in acid urine it is present in the condition in which it shows the so-called alkaline spectrum (p. 345, Fig. 231, 11).

APPENDIX.

ANALYTICAL TABLES.

(OUTLINE OF METHOD FOR DETECTION OF VARIOUS PHYSIOLOGICAL CHEMICAL SUBSTANCES IN A MIXTURE.)

The following Physical Properties should be noted :

I. Appearance.

A. Powder.—Dust some on to a slide and examine under the microscope for starch grains and crystals. Dissolve some in a suitable solvent.

B. Solution.

1. **Opaque**—may be due to :

- (a) suspended fat globules—clear up with ether ;
- (b) certain inorganic salts—clear up with mineral acid ;
- (c) certain proteids.

2. **Opalescent**—may be due to :

- (a) glycogen or starch—iodine reaction ;
- (b) certain proteids.

3. **Deeply coloured**—suspect blood.

II. Reaction.

A. Acid—may be due to :

- (a) free acid
 - (b) acid salt
- } apply Congo red test.

If due to free acid, ascertain whether this be

- 1. a mineral acid or
 - 2. an organic acid
- } apply Gunsberg's and the tropaeolin test.

If due to an organic acid, apply Uffelmann's test for lactic acid.

B. Alkaline test for carbonic acid (effervescence with mineral acid), ammonia (smell, etc.), caustic alkali.

The following Chemical Tests should now be applied to Suitable Quantities of the Solution.

I. For Carbohydrates.

1. Apply Trommer's test.

A. Positive—indicates monosaccharides, lactose, or maltose.

B. Negative, but complete solution of cupric hydrate obtained on adding caustic alkali, indicates cane sugar. Confirm for this by boiling some of the solution with a mineral acid for a minute or so, and applying Trommer's test to the product—reduction indicates cane sugar. The original solution will also taste sweet.

C. Negative, and no solution of cupric hydrate. Absence of monosaccharides and disaccharides.

2. Add Iodine Solution.

(a) a blue colour which disappears on heating, and returns on cooling indicates *starch*.

(b) a port-wine colour which disappears on heating, and returns on cooling indicates *dextrin* or *glycogen*. Confirm for polysaccharides by heating some of the original fluid for about fifteen minutes with a mineral acid, and testing for *sugar* in the hydrolysed fluid.

To distinguish between Starch, Glycogen, and Dextrin.—Shake up some of the original powder with *cold* water and filter. By this treatment glycogen and dextrin will dissolve, starch will not. Wash the filter paper thoroughly with water, then add a drop of Iodine solution—a blue stain indicates starch. Add Iodine solution to the filtrate—a red colour indicates dextrin or glycogen; if the former body be present the filtrate is clear, opalescent if the latter.

To distinguish between Dextrose, Maltose, and Lactose.

(1) Prepare **osazone crystals** and examine under the microscope—dextrosazone gives long thin needles; maltosazone, short thick needles; lactosazone, needles of varying length and thickness.

(2) **Barfoed's reaction** may also be tried. Dextrose reduces this with ease; lactose and maltose not so readily.

II. For Proteins.

1. Apply the **Biuret reaction**—(a) A violet colour indicates native proteins or albuminoids; (b) a rose pink colour, proteose or peptone.

2. Apply **Millon's** and the **Xantho-proteic** tests.

- (a) A well-marked reaction indicates proteins of Kossel's 3rd and 4th groups. (b) A faint reaction (combined with a distinct Biuret, and the absence of coagulation on boiling) points to **gelatine** (2nd group). (Confirm by seeing if the solution gelatinises on cooling).

If the Biuret Test gives a Violet Colouration,

A. Add a drop or so of dilute acetic acid and boil. A coagulum points to **native proteins**. To ascertain which of these is present (*i.e.* albumin or globulin), half saturate some of the solution with $(\text{NH}_4)_2\text{SO}_4$. A precipitate indicates **globulin**; filter; if the filtrate still gives a coagulum on boiling, **albumin** is present.

B. Carefully neutralise some of the solution. A precipitate may be:

- | | |
|--|---|
| 1. Alkali Meta-protein —original fluid alkaline | } the precipitate re-dissolves on adding excess of acid or alkali. |
| 2. Acid Meta-protein —original fluid acid | |
| 3. Nucleo-protein —original fluid alkaline | } precipitate does not disappear on adding a moderate excess of acid. |
| 4. Mucin —original fluid alkaline | |

To distinguish between Nucleo-protein and Mucin.—This is possible only when a large amount of these bodies is present. The acetic acid precipitate is collected on a filter paper, washed with acidulated water, and divided into two portions *a* and *b*.

(a) Boil with 20 per cent. HCl for 10 minutes; cool; neutralise; apply Trommer's test. A positive reaction points to *mucin*.

(b) Melt in a crucible with fusion mixture; after the ash cools, dissolve it in nitric acid and add molybdate of ammonia solution. A yellow precipitate on warming indicates **Nuclein**.

If the Biuret Test gives a Rose Pink Colouration, add a few drops of concentrated pure nitric acid.

A. A **white precipitate**, which clears up on warming and returns on cooling, points to **Proteose**. Confirm by the salicyl sulphonic acid test.

If proteose be present, saturate some of the original fluid, from which native proteins have been separated by boiling, with sodium chloride. A precipitate indicates

primary proteoses. Filter and add a drop of acetic acid ; a precipitate points to **secondary proteoses.**

B. **No precipitate** with nitric acid, but a distinct pink Biuret reaction points to **Peptone.** Confirm by saturating the original fluid with ammonium sulphate, filtering and applying the Biuret test to the filtrate.

When two or more **Proteins** are present, the following method will be found very useful.

Add a few drops of salicyl sulphonic acid to several c.c. of the original fluid. A white precipitate may indicate native protein or proteoses. Boil. The proteoses dissolve, whereas the native protein becomes coagulated. Filter hot. If a precipitate forms in the filtrate on cooling, it indicates **Proteoses.** Filter off this precipitate and apply the Biuret test to the filtrate. A rose pink colouration indicates **Peptone.**

III. For Fats.—In watery solution fat may be dissolved as a *soap*. The presence of this can be detected by pouring some of the original fluid into about 20 c.c. of 20 per cent. H_2SO_4 contained in a small beaker, and heated to near boiling point. If soap be present a film of fatty acid will form on the surface of the fluid.

IV. The following substances should also be tested for. I. **Bile salts**—Pettenkofer's reaction ; II. **Bile Pigments**—Gmelin's test.

V. Urea (1).—Add some fuming nitric to some of the original fluid. Effervescence points to urea.

(2) Repeat with hypobromite solution.

(3) If 1 and 2 be positive, confirm by obtaining urea nitrate crystals. To do this evaporate about 30 c.c. of the original fluid to small bulk, extract residue with six times its bulk of methylated spirit, evaporate this extract to dryness, dissolve residue in 3-4 c.c. distilled water, and add to the resulting fluid a few c.c. of *pure* nitric acid, meanwhile keeping the test-tube cool by holding it under the tap. Crystals of urea nitrate separate out if urea is present. Examine under microscope.

VI. Uric Acid.—Apply Murexide test.

VII. Blood Pigment.—(1) Examine by means of the spectroscope. *A*, the original fluid ; *B*, the same after reduction ; *C*, the same after the addition of caustic alkali and heating. By this latter method alkali haematin is formed. This itself does not give a very distinct absorption band, but if a reducing agent (NH_4HS) be added to it haemochromogen is formed, which has two very distinctly marked bands in about the same position as those of oxyhaemoglob. in

(2) Apply the guaiac and ozonic ether test.

When it is desired to ascertain whether Ferments be present it is necessary to add a piece of coagulated egg-white, or of washed fibrin to the original fluid, and to place the mixture on a water bath heated to body temperature. If, after an hour, the digest gives a distinct proteose reaction, and this was not obtained in the original fluid, the presence of a proteolytic ferment may be assumed; **pepsin**, if the original fluid react acid, and **trypsin**, if it react alkaline. If proteoses are present in the fluid itself, Mett's method must be employed to identify the ferment.

For the detection of **Amylolytic** and **Steatolytic** ferments, the methods described in the text must be employed.

For the detection of the various substances which may occur in the urine, the test and reactions described in the text must be applied.

INDEX.

PART I.—EXPERIMENTAL PHYSIOLOGY.

- Aberration, chromatic, 258.
spherical, 258.
Accommodation of eye, 234.
After-images, 244.
Air, alveolar, 183, 197.
complemental, 178.
expired, 182.
inspired, 180.
supplemental, 178.
tidal, 178.
Alimentary canal, movements of, 203.
Ametropia, 260.
Anelectrotonus, 50, 83, 86.
Anode, 3.
Apnoea, 196, 199.
Asphyxia, 146.
Astigmatism, 232, 258.
Atropine, effect of, upon frog's heart,
110, 111.
upon salivary glands, 212.
Auscultation, 176.
Bell's law, 220.
Biedermann's solution, 68.
Blind spot, 241.
Blood, circulation of, 131.
corpuscles, number of, 128.
gases, 187.
pressure, 121, 139, 140, 144, 165.
oxygen capacity of, 191.
specific gravity of, 131.
Brain, frog's, 214.
Break extra current, 11.
Cannula, arterial, 139.
Capacity, vital, 178.
Carbon dioxide, influence of, 195.
monoxide, influence of, 194.
Cardiograph, 119.
Cardiometer, 170.
Cerebellum, effects of removal of, 215.
Cerebrum, effects of removal of, 214.
Chest, auscultation of, 176.
examination of, 174.
inspection of, 174.
palpation of, 175.
percussion of, 175.
Cheyne-Stokes respiration, 197.
Chloroform, effect of, on frog's heart,
112.
effect on frog, 216.
Chronograph, 23.
Circulation of blood, artificial schema
of, 134, 135.
influence of gravity on, 132, 137,
147, 148.
proofs of, 131.
time, 138, 169.
velocity of, 136.
Clonus, 219.
Colour blindness, 253.
complementary, 250.
sensations of, 245.
Contraction, remainder, 38, 39, 44.
secondary, 52.
single, 22, 25, 40.
voluntary, 220.
Cord, spinal, effects of removal of,
215.
roots of, 220.
Cornea, action of, 233.
Corpora striata, effects of removal of,
214.
Curare, 48.
Current action, 51, 91.
demarcation, 51, 91.
injury, 52, 91.
Cytometer, 174.
Daniell cell, 2.
Defaecation, 210.
Dioptré, 232.

- Drum, recording, 18.
 Du Bois-Reymond's key, 4.
- Ear, dissection of, 267.
 Elasticity of muscle, 53.
 Electrodes, 6.
 polarisation of, 78.
 unpolarisable, 79.
 Electrometer, capillary, 92.
 Electrotonus, 50, 82, 86.
 Emmetropia, 259.
 Emprosthonus, 216.
 Endiometer, 188, 189.
 Ergograph, 71.
 Ether, effect of, on frog's heart, 114.
 Exchange, respiratory, 184, 186.
 Extensibility of muscle, 53.
 Eye, accommodation of, 234.
 artificial, 233.
 dissection of, 226.
 mechanism of, 228.
 media of, 232.
 optical defects of, 258.
 "reduced," 228.
- Faradic shocks, 12.
 Fatigue, 38, 39, 70.
 absence of, in nerve, 87.
 effect of circulation of blood on, 72.
 Flicker, 247.
 Fremitus, vocal, 175.
- Galvani's experiment, 52.
 Galvanometer, 90.
 Gas, analysis of, 181.
 of blood, 187.
 pump, 188.
 tension of, 183.
- Gaskell's clamp, 154.
 Gracilis experiment, 80.
 Gravity, influence of, on circulation, 132, 137, 147, 148.
- Haemacytometer, 130.
 Haemoglobinometer, 129.
 Hearing, 267.
- Heart, anatomy of frog's, 92.
 anatomy of sheep's, 115.
 apex preparation of, 95.
 beat, methods of recording, 97.
 contraction of, 94, 149.
 effect of temperature on, 94, 99, 101, 154.
 effect of distilled water on, 152.
 effect of drugs, 70, 109, 112, 151.
 ganglia of, 96, 103.
 latent period of, 149.
 nerves of, 103, 156.
 output of, 170.
 refractory period of, 103, 150.
 rhythm of, 94.
 sounds of, 121.
- Heart, Stannius, 100.
 valves of, 115, 119.
 work of, 169.
- Heat, loss of, 201.
 regulation of, 200.
- Helmholtz, arrangement for equalisation of make and break induced currents, 13.
- Hooke's law, 54.
 Hyoglossus muscle, 30.
 Hypermetropia, 259.
- Images, Purkinje-Sanson, 336.
- Impulse, cardiac, 119.
 nervous, rate of transmission of, 76.
 nervous, rate of discharge of, 217.
 nervous, transmission in both directions, 79.
- Induced currents, equalisation of make and break, 12, 13.
- Induction coil, 8.
 Induction shocks, 10.
- Inhibition of frog's heart, 105, 106.
 Inspection of thorax, 174.
 Intestine, movements of, 208.
 Iris, action of, 234.
 Irradiation, 253.
 Isotonic solutions, 69.
- Katelectrotonus, 51, 81.
 Kathode, 3.
 Keys, 4, 5.
 Kidney, volume of, 172.
 Kymograph, 18, 143.
- Latent period of muscular contraction, 26.
- Law of specific energy, Müller, 222.
 Bell and Majendie, 220.
 Talbot and Plateau, 247.
 Hooke, 54.
- Lens crystalline, action of, 233.
 changes in, during accommodation, 234.
- Levers for muscle, 17.
- Lippmann's capillary electrometer, 92.
- Load, effect upon muscular contraction, 35, 57.
- Manometer, 127, 142, 166, 167.
 Medulla oblongata, effects of removal of, 215.
 Metronome, 215.
 Müller's Law, 222.
 Murmur, vesicular, 176.
 Muscarine effect on heart, 109.
 Muscle, independent excitability of, 80.
 electromotive properties of, 89, 90.
 elasticity of, 53.
 action of veratrine on, 29.

- Muscle, action of distilled water on, 67.
action of salts on, 67.
- Muscle and nerve, preparation, 14, 16.
- Muscle-lever, 17.
- Muscles of the frog's leg, 15.
- Muscular contraction, 22.
shortening during, 29.
work during, 29, 57.
conditions affecting, 29, 32, 35.
red and white muscles, 29, 30.
effect of temperature on, 32, 33.
effect of load on, 35, 37.
effect of fatigue on, 38, 39.
- Myograph, 16, 17.
spring, 64.
pendulum, 66.
- Myopia, 261.
- Nerve, properties of, 44.
electrical stimulation of, 46.
mechanical stimulation of, 47.
thermal stimulation of, 47.
chemical stimulation of, 47.
relation between muscle and, 80.
electromotive properties of, 51, 88.
vago-sympathetic, 104, 108.
impulse, rate of transmission of, 76.
depressor, 140, 146.
chorda tympani, 211.
vagus, dissection of, 157.
effect of constant electrical current on, 81.
cervical sympathetic, 158.
specific energy of, 222.
splanchnic, 172.
roots, functions of, 220.
vaso-motor, 137.
sweat, 202.
- Nervous system, central, 214.
- Nicotine, 112, 212.
- Oncometer, 171.
- Ophthalmometer, 230.
- Ophthalmoscope, 265.
- Oxygen, effect of, 196.
- Pain, sense of, 224.
- Palpation, 175.
- Percussion, 175.
- Perfusion of blood-vessels, 164.
- Pericardium, 115.
- Perimeter, 263.
- Phakoscope, 237.
- Phosphenes, 243.
- Photohaematochrometer, 169.
- Piezometers, 168.
- Pilocarpine, 213.
- Plethysmograph, 171, 173.
- Pohl's reverser, 5.
- Presbyopia, 259.
- Pressure, blood, in man, 127.
blood, 140, 157.
- Pressure, intracardiac, 166.
intra-thoracic, 176.
atmospheric, effects of changes in, 192, 193.
- Pulse, 121, 161.
- Pump, blood-gas, 188.
air, 192.
- Purkinje-Sanson images, 236.
- Purkinje's figures, 240.
- Reaction time, 216.
- Recorder, bellows, 220.
- Reed vibrating, 42, 43.
- Reflex, 214.
- Refractory period, voluntary muscle, 42.
of heart, 103, 150.
- Refraction, errors of, 258.
- Respiration, movements of, 180.
chemistry of, 180, 187.
regulation of, 195, 199.
centre for, 195.
apparatus, 184, 186.
in tissues, 402.
- Respiratory exchange, 184, 186.
quotient, 185.
- Retina, 240.
- Reverser, Pohl's, 6.
- Rheochord, 7.
- Rheoscopic frog, 52.
- Rigor, heat, 34.
- Ringer's solution, 69.
- Rubber, elasticity of, 56.
- Saline solution, normal, 69.
- Salivary glands, dissection of, 211, 212.
- Salts, action of, on muscle, 67.
- Sanson-Purkinje images, 236.
- Sartorius experiment, 79.
- Scheiner's experiment, 238.
- Secretion, salivary, 210.
- Sensations, 222, 223.
- Shatter curves, 28.
- Sino-auricular junction of frog's heart, stimulation of, 109.
- Skin, sensibility of, 222, 223.
- Smell, 222.
- Sounds, bronchial, 176.
cardiac, 121.
- Specific gravity of blood, 131.
- Sphygmograph, 123.
- Sphygmogram, 125.
- Sphygmometer, 127.
- Sphygmoscope, 166.
- Spinal animal, 160, 215.
- Spirometer, 178.
- Stannius experiment on heart, 100.
- "Stair-case" effect in voluntary muscle, 40.
cardiac, 150.
- Stethograph, 179.
- Stethoscope, 176.

- Stimuli, minimal and maximal, 19, 46.
 successive, 40, 41.
 summation of, 62.
 Stomach, movements of, 205.
 Stromühr, 136.
 Strychnine, action of, 216, 219.
 Submaxillary gland, 211, 212.
 Summation of contraction, 41, 42.
 of stimuli, 62.
 Suprarenal extract, 164, 165.
 Swallowing, 203.
 Sweat, 202.

 Talbot-Plateau law, 247.
 Taste, 222.
 Temperature, effect of muscular exercise on, 200.
 effect on heart, 94, 101, 154.
 of body, 201.
 effect of anaesthesia on, 202.
 regulation of, 201.
 sense of, 224.
 Tetanus, genesis of, 40.
 incomplete, 44, 45, 219.
 complete, 44, 45.
 secondary, 53.
 Thalami, optic, effects of removal of, 214.

 Thermometry, 200.
 Thorax, inspection of, 174.
 Tuning-fork, 22, 23.
 Türck's experiment, 215.

 Unipolar excitation, 21.

 Vagus (vago-sympathetic), dissection of, in frog, 104, 108.
 stimulation of, effect on heart of frog, 105, 106.
 influence on respiration, 145, 199.
 influence on arterial pressure, 145.
 Varnish, for tracings, 19.
 Vaso-motor system, 137, 164.
 Veratrine action upon muscle, 29.
 Vision, 226.
 field of, 263.
 binocular, 254.

 Water, distilled, action on muscle, 67.
 action on heart, 151.
 Weber's paradox, 57.
 Wind, second, 197.
 Work done by muscle during contraction, 35, 57.
 by heart during contraction, 169.

 Yellow spot, 242.

INDEX.

PART II.—PHYSIOLOGICAL CHEMISTRY.

- Acetone in urine, 452.
Achroodextrin, 291.
Acid, aceto-acetic, 453.
 aspartic, 299, 392.
 carnic, 355.
 cholalic, 399.
 cyanuric, 417.
 fatty, 313.
 glycocholic, 399.
 glycuronic, 454.
 hippuric, 428, 441.
 homogentisic, 453.
 hydrochloric, tests for, 377.
 lactic, 354, 454.
 nucleic, 310.
 oleic, 314.
 oxybutyric, 453.
 palmitic, 313.
 sarcolactic, 358.
 stearic, 313.
 taurocholic, 399.
Acrolein, 316.
Adamkiewicz reaction, 303.
Adenine, 423.
Agglutination, 464.
Albumin, 305.
 crystals, 301.
 quantitative estimation, 445.
Albuminuria, 442.
Aldoses, 272.
Alexine, 464.
Alloxan, 424.
Alloxuric bodies, 422.
Amboceptor, 465.
Amido acids, 389.
Ammonia in urine, 431, 433.
Amylopsin, 396.
Arginine, 392.

Bang's method, 293, 295.
Barfoed's reagent, 275.

Bence Jones' alhumosuria, 445.
Bial's reagent, 295.
Bile, composition of, 397.
Bile salts, 399.
 pigments, 400.
Bilirubin, 400.
Biliverdin, 400.
Biuret, 417.
Biuret reaction, 302.
Blood, 331.
 clotting of, 332.
Boettger's test, 449.
Bread, 365.
 making of, 365.

Calorie, 360.
Camerer's method, 427.
Carbohydrates, 272-296.
Carnic acid, 355.
Caseinogen and casein, 298, 326.
Cholesterol, 318, 401.
Cholin, 317.
Chromo-proteins, 308.
Collagen, 307.
Colorimeter, 430.
Colostrum, 330.
Complement, 464.
Congo red, 377.
Creatin, 352, 356.
Creatinin, 352, 429.
Cystin, 393, 441.

Dextrin, 290.
Dextrose, 284, 450.
Diet, 359.
Digestion, 371.
 bacterial, 404.
 in intestine, 387.
 in mouth, 371.
 in stomach, 375.
Disaccharides, 285.

- Dubosq colorimeter, 430.
 Dupré's urea apparatus, 420.
 Edestin, 298.
 Eggs, composition of, 362.
 Elastin, 307.
 Emulsification, 316.
 Erepsin, 403.
 Erythro-dextrin, 291.
 Esbach's albuminometer, 445.
 Ester value, 322.
 Faeces, 407.
 Fats, 313.
 Fatty acids, 313.
 Fehling's test, 274.
 Fermentation test for sugar, 279,
 449.
 Fibrin, 334.
 ferment, 336.
 Fibrinogen, 334.
 Flour, 364.
 Folin's method, for ammonia, 432.
 for urea, 421.
 for creatinin, 429.
 Foods, 359, 366.
 Galactose, 285.
 Gall-stones, 319.
 Gelatin, 307.
 Gerrard's method, for sugar, 451.
 Gerrard's urea apparatus, 420.
 Gliadin, 298.
 Globulins, 305.
 Gluco-proteins, 308.
 Glucose, 284, 450.
 Glutenin, 298.
 Glycin, 390.
 Glycogen, 290.
 Glycosuria, 447, 450.
 Glycuronic acid, 454.
 Glyoxylic acid test, 303.
 Gmelin's test, 400.
 Grutzner's method, 386.
 Guanine, 423.
 Guaiac test, 340.
 Günsberg's reagent, 377.
 Haematin, 339.
 Haematocrit, 461.
 Haematoporphyrin, 349.
 Haematuria, 447.
 Haemin, 341.
 Haemochromogen, 349.
 Haemocytes, 329.
 Haemoglobin, 339.
 and derivatives, 344.
 Haemoglobinuria, 447.
 Haemolysin, 464.
 Haemolysis, 460.
 Hay's test, 398.
 Heller's test, 444.
 Hexone bases, 392.
 Hippuric acid, 428.
 Hirudin, 335.
 Histones, 305.
 Hopkins' test, 303, 380.
 Hypoxanthin, 353, 357, 423.
 Inactivation, 465.
 Indican, 410.
 Indol, 405.
 Inosite, 355.
 Inversion, 403.
 Invertase, 403.
 Iodine number of fats, 314, 323.
 Isomaltose, 287.
 Jaffé's test, 429.
 Juice, gastric, 376.
 intestinal, 403.
 pancreatic, 388.
 Keratin, 307.
 Ketoses, 278.
 Kjeldahl's method, 410.
 Kresol, 405.
 Lactic acid, 354.
 Lactose, 287, 329, 448.
 Laevulose, 285.
 Lecithin, 316, 401.
 Legal's test, 406.
 Leucin, 389, 391, 441.
 Leucocytes, chemistry of, 338.
 Lieberkühn's jelly, 311.
 Lipase, 396.
 Lysine, 392.
 Maltose, 287.
 Meat, 350.
 Meat extracts, 350.
 Metabolism, 359, 367, 437.
 Meta-protein, 310.
 Methaemoglobin, 347.
 Mett's method, 386.
 Milk, 324.
 fats of, 330.
 proteins of, 326.
 salts of, 329.
 sugar of, 329.
 Millon's reaction, 302.
 Molisch test, 279, 303.
 Monosaccharides, 272.
 Moore's test, 284.
 Möerner-Folin method, 421.
 Mucin, 308.
 Mucus, 446.
 Murexide test, 425.
 Muscle, 350.
 extractives of, 350.
 Myosin, 351.
 Nitrogen, estimation of, 410.
 Nucleic acid, 310.
 Nucleins, 310.

- Nucleo-proteins, 309.
 Nylander's test, 274.

 Olein, 314.
 Ornithin, 393.
 Osazone, 275.

 Palmitic acid, 313.
 Pancreatic digestion, 388.
 Parry's method, for sugar, 451.
 Pentoses, 294, 448.
 Pepsin, 382.
 Peptone, 311.
 Pettenkofer's reaction, 398.
 Phenol, 405.
 Phenyl hydrazine, 275.
 Phosphoproteins, 306.
 Plasma, 337.
 Polarimeter, 282.
 Polarisation of light, 280.
 Polypeptides, 299.
 Polysaccharides, 288.
 Precipitins, 460.
 Protagon, 320.
 Protamines, 305.
 Proteins, 297.
 classification of, 304.
 tests for, 300.
 Proteose, 311.
 Ptyalin, 372.
 Purin bodies, 422.
 Pus, 446.

 Reichert-Meissl value, 322.
 Rennin, 327.
 Rothera's test, 453.

 Saccharimeter, 282.
 Salicyl-sulphonic acid test for albumin, 445.
 Saliva, 371.
 Saponification, 314.
 Saponin, 462.
 Sarcosine, 358.
 Schiff's test, 427.
 Sclero-proteins, 307.
 Seliwanoff's test, 278.
 Serum, 336.
 Shaffer's method, 433.
 Skatol, 405.
 Soap, 314.
 Soxhlet's apparatus, 313.
 Spectra, 345, 348.
 Spectroscopy, 343.
 Starch, 288.
 Steapsin, 396.
 Stercobilin, 407.
 Succus entericus, 403.
 Sugar, cane, 286.

 Sugar, estimation, 293.
 grape, 284, 450.
 milk, 287.
 Syntonin, 311.

 Taurin, 400.
 Thiophene test, 455.
 Thrombin, 334.
 Thrombogen, 334.
 Thrombokinase, 334.
 Trommer's test, 274.
 Tropaeolin test, 378.
 Trypsin, 389.
 Tryptophane, 395.
 Tyrosin, 389, 391, 441.

 Uffelmann's reagent, 354.
 Urates, 438.
 Urea, 415.
 nitrate, 416.
 oxalate, 416.
 quantitative estimation of, 419.
 Ureometer, 421.
 Uric acid, 422, 426.
 quantitative estimation of, 427.
 Urine, acetone in, 452.
 ammonia in, 431.
 bile in, 447.
 blood in, 446.
 chlorides in, 434.
 colour of, 410.
 composition of, 410.
 deposits in, 438.
 inorganic salts of, 434.
 pathological, 442.
 pigments of, 467.
 phosphates in, 435.
 quantity of, 408.
 reaction of, 409.
 specific gravity of, 409.
 sugar in, 447, 450.
 sulphates in, 435.
 total nitrogen of, 410.
 Urobilin, 467.
 Urochrome, 467.
 Uroerythrin, 468.

 Volhard's method for chloride, 434.

 Weyl's reaction, 429.
 Wheat, 364.
 Worm, Müller test, 449.

 Xanthin, 353, 357, 423.
 Xanthroproteic reaction, 302.

 Yeast, 279.

 Zein, 298.

