

Model 66366 Mesa Series Single Pedestal Desk

Parts Listing

A
Desk Top
1 Unit

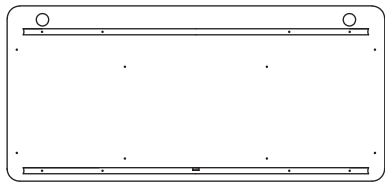

B
Side Panel Legs
2 Units

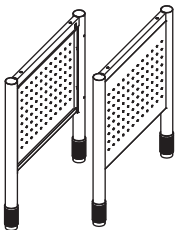

C
Pedestal
1 Unit

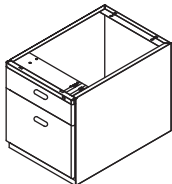

D
Privacy Panel
1 Unit



E
Drawer Runners
2 Units

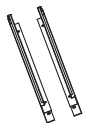

F
Drawer
1 Unit

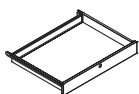

G
6x55mm Screw
4 Units



H
10x35mm Screw
4 Units



I
6x16mm Screw
12 Units



J
Allen Wrench
1 Unit



K
Phillips Head
Screw Bit
1 Unit

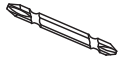

L
Corner
Leg Bracket
4 Units

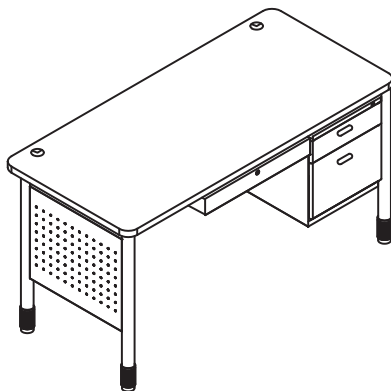
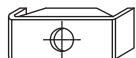

Assembly Instructions

Tools Needed: Phillips Head Screwdriver

Please read all instructions before assembly. Assembly will require 2 people.

The following instructions result in a 66366L-ready desk. For a 66366R, please assemble Pedestal on opposite side.

Step 1: Align Side Panel Legs (B) with the support rail on the underside of the Desk Top (A). Place Corner Leg Bracket (L) in holes on support rail, and insert 10x35mm Screw (H) through bracket and into legs. Tighten using Allen Wrench (J). Align Drawer Runners (E) with holes in underside of the Desk Top (A). Attach using 6x16mm Screws (I) and Phillips Head Screw Bit (K).

Step 2: Attach Pedestal (C) to underside of Desk Top (A) by aligning screw holes in Pedestal with holes in Desk Top, and inserting 6x55mm Screws (G) to secure. Tighten using Phillips Head Screw Bit (K) or screwdriver.

Step 3: Attach Pedestal (C) to Side Panel Legs (B) by inserting 6x16mm Screws (I) through pedestal wall and into legs. Tighten using Phillips Head Screw Bit (K) or screwdriver.

Step 4: Attach Privacy Panel (D) to Pedestal (C) by inserting 6x16mm Screws (I) through side of Privacy Panel (D) and into the side of Pedestal (C). Attach Privacy Panel (D) to Side Panel Legs (B) by inserting 6x16mm Screws (I) through other side of Privacy Panel (D) and into the corresponding hole on the inside of the Side Panel Leg (B). Tighten using Phillips Head Screw Bit (K).

Step 5: Flip the desk right side up using at least two people. Insert the Drawer (F) backwards, as shown, aligning it with the Drawer Runners (E). Push Drawer (F) all the way in to secure.



If you have Model 66366R or 66366L, please proceed to next page for Return assembly.

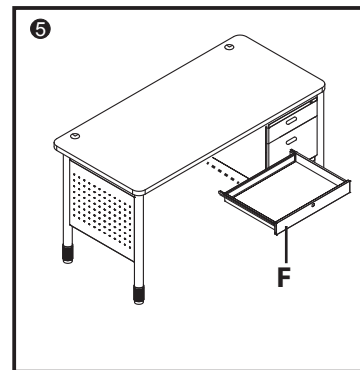
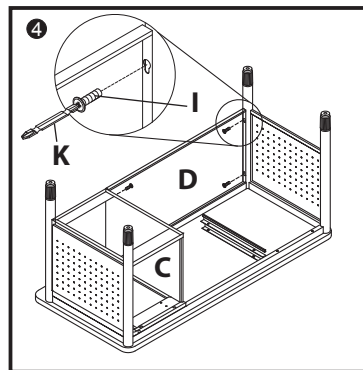
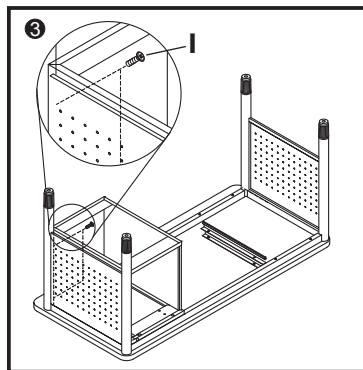
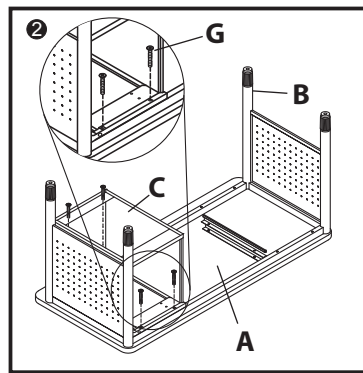
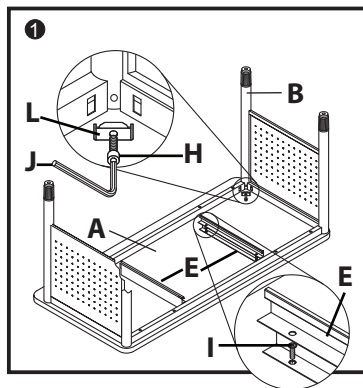

Assembly Notes:

During assembly, hand tighten screws only. When all screws are in place, you may then tighten all screws completely.

CAUTION:

1. Do not use this desk as a step ladder.
2. Check for loose screws and tighten them every 6 months.

ofm
Furniture For The Real Office™

161 Tradition Trail, Holly Springs, NC, 27540
800-520-7471 (voice) 919-362-4765 (fax)
919-303-6389 (voice) www.ofminc.com
support@ofminc.com

Model 66366L / 66366R Mesa Series L-Shaped Pedestal Desk Return

Parts Listing

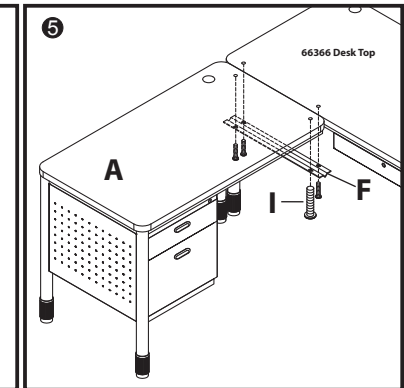
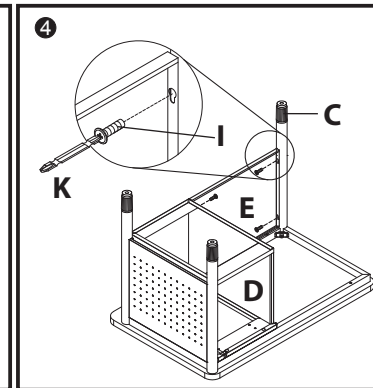
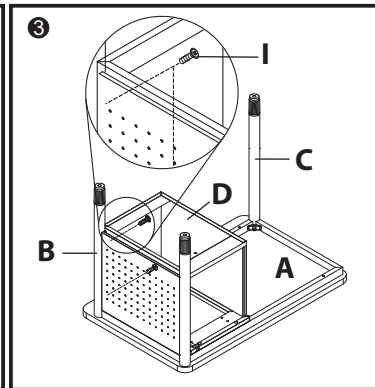
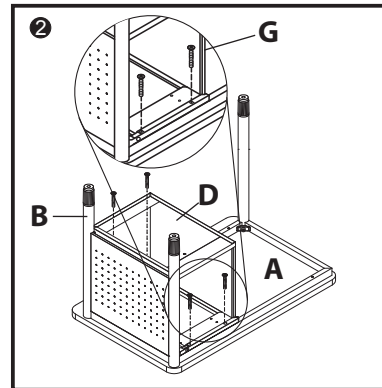
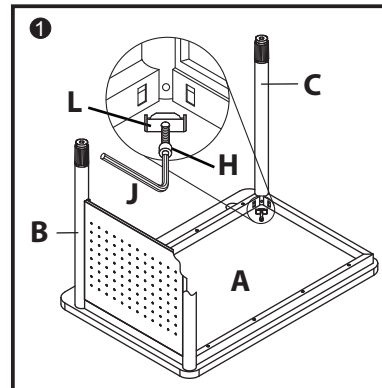
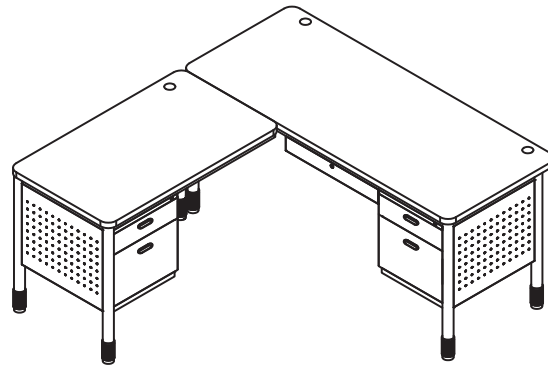
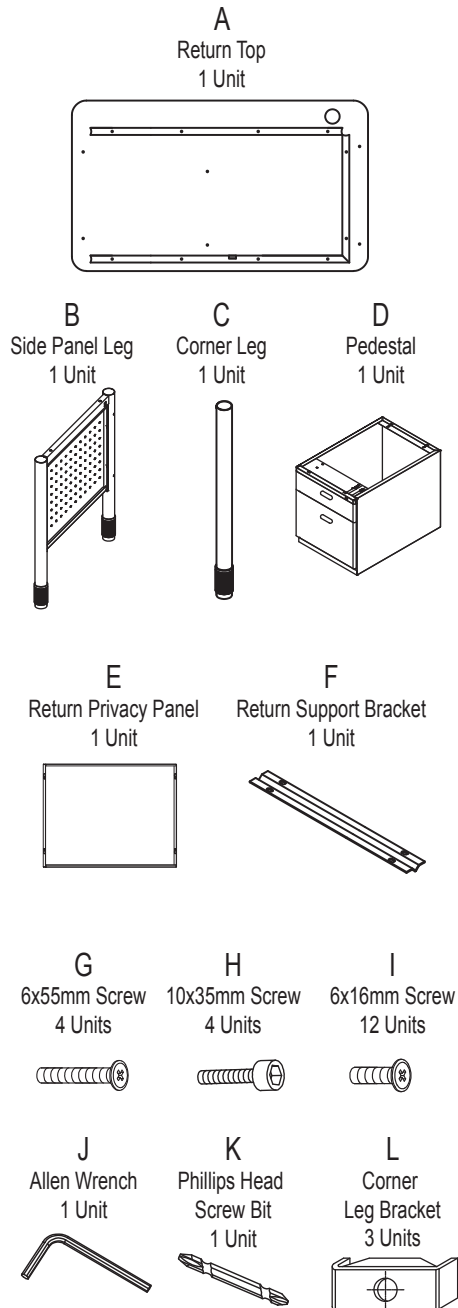

Assembly Instructions



Tools Needed: Allen Wrench and Phillips Head Screw Bit

Please read all instructions before assembly. Assembly will require 2 people.

The following instructions should only be used following the assembly of a 66366 desk.

Step 1: Align Side Panel Legs (B) with the support rail on the underside of the Return Top (A). Place Corner Leg Bracket (L) in holes on support rail, and insert 10x35mm Screw (H) through bracket and into legs. Tighten using Allen Wrench (J). Align Corner Leg (C) with the support rail on the underside of the Return Top (A). Place Corner Leg Bracket (L) in holes on support rail, and insert 10x35mm Screw (H) through bracket and into legs. Tighten using Allen Wrench (J).

Step 2: Attach Pedestal (D) to underside of Return Top (A) by aligning screw holes in Pedestal with holes in Return Top (A), and inserting 6x55mm Screws (G) to secure.

Step 3: Attach Pedestal (D) to Side Panel Leg (B) by inserting 6x16mm Screws (I) through pedestal wall and into legs. Tighten using Phillips Head Screw Bit (K) or screwdriver.

Step 4: Attach Privacy Panel (E) to Pedestal (D) by inserting 6x16mm Screws (I) through side of Privacy Panel (E) and into the side of Pedestal (D). Attach Privacy Panel (E) to Corner Leg (C) by inserting 6x16mm Screws (I) through other side of Privacy Panel (E) and into the corresponding hole on the inside of the Corner Leg (C).

Step 5: Flip the return right side up using at least two people. Line up with the appropriate position on 66366 Desk. Attach by inserting 6x16mm Screws (I) up through Return Support Bracket (F) to secure to both the Return Top (A) and the 66366 Desk Top.

Assembly Notes:

During assembly, hand tighten screws only. When all screws are in place, you may then tighten all screws completely.

CAUTION:

1. Do not use this desk as a step ladder.
2. Check for loose screws and tighten them every 6 months.

ofm
Furniture For The Real Office™

161 Tradition Trail, Holly Springs, NC, 27540
800-520-7471 (voice) 919-362-4765 (fax)
919-303-6389 (voice) www.ofminc.com
support@ofminc.com

66000 Series How to Remove the Pedestal Drawers

Drawer Removal Instructions

STOP Please read all instructions before you begin.
All Pedestal Drawers must be removed before attaching the Pedestal to a desk.

- Step 1:** Stand in front of the pedestal and open the drawer you wish to remove.
Pull drawer all the way out until met with resistance.
- Step 2:** With both hands, place fingers underneath the open drawer on each side near the drawer release/locking lever (highlighted below) like you would be picking up the drawer. Keep hold of the drawer and using just your pointer finger on your right hand and your thumb on your left hand, simultaneously push the lever **UP on the right side** and push **DOWN on the left side**. While continuing to hold both levers in the correct pushed position, pull the drawer out.
- Step 3:** To put the drawer back in, simply align the rails on the drawer with the tracks on the pedestal unit and push in.

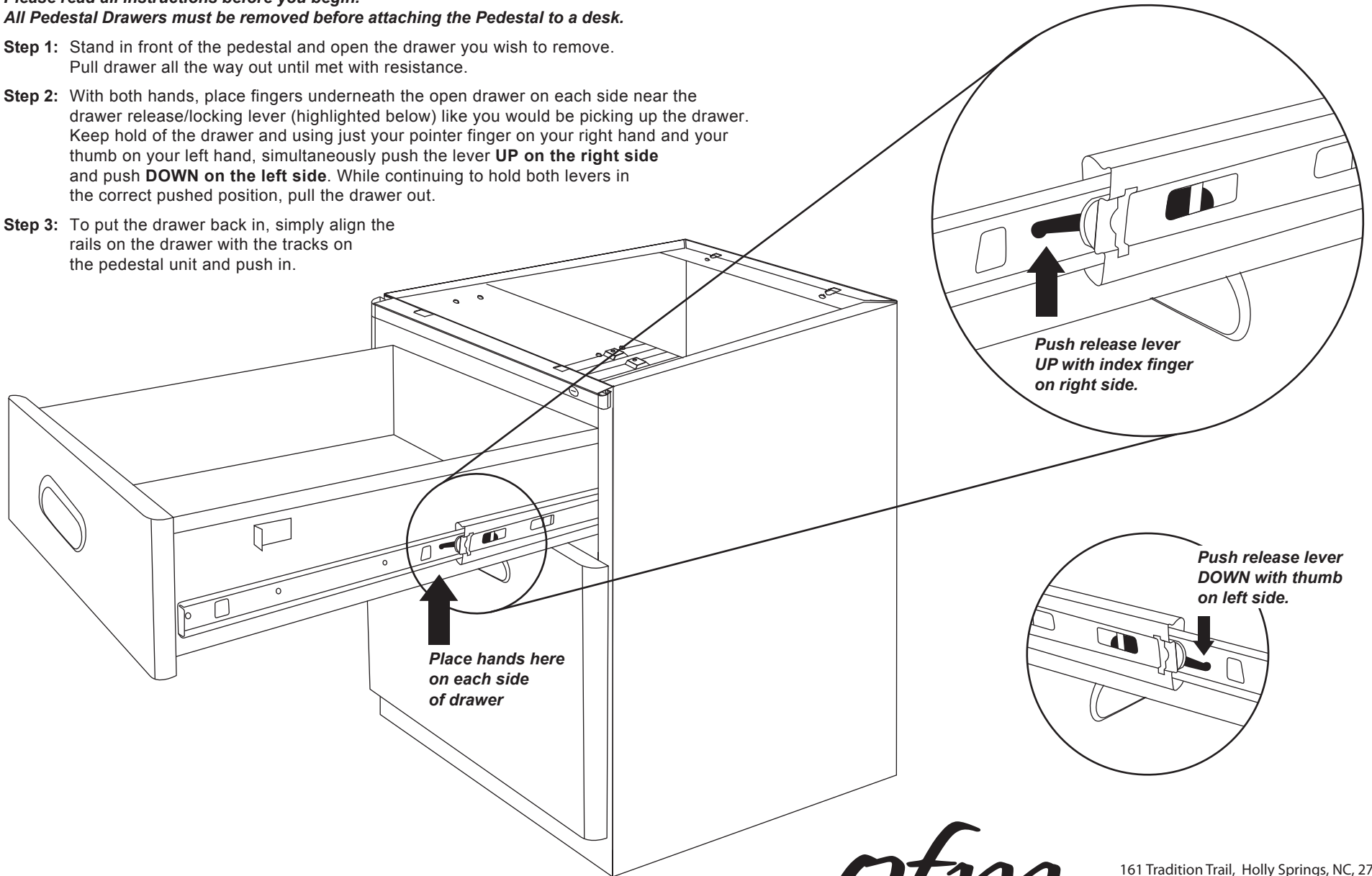

ofm
Furniture For The Real Office™

161 Tradition Trail, Holly Springs, NC, 27540
800-520-7471 (voice) 919-362-4765 (fax)
919-303-6389 (voice) www.ofminc.com
support@ofminc.com