



# 99700-1152

ANTIGUA & WHITE CHOCOLATE : ANTIGUA ET CHOCOLAT BLANC :  
ANTIGUA Y CHOCOLATE BLANCO  
WWW.BESTAR.CA : 1-888-8BESTAR (1 888 823-7827)

MODEL : MODÈLE : MODELO

# 99700-1139

BORDEAUX & GRAPHITE : BORDEAUX ET GRAPHITE : BURDEOS Y GRAFITO  
WWW.BESTAR.CA : 1-888-8BESTAR (1 888 823-7827)

# 99700-1169

CHOCOLATE : CHOCOLAT : CHOCOLATE  
WWW.BESTAR.CA : 1-888-8BESTAR (1 888 823-7827)

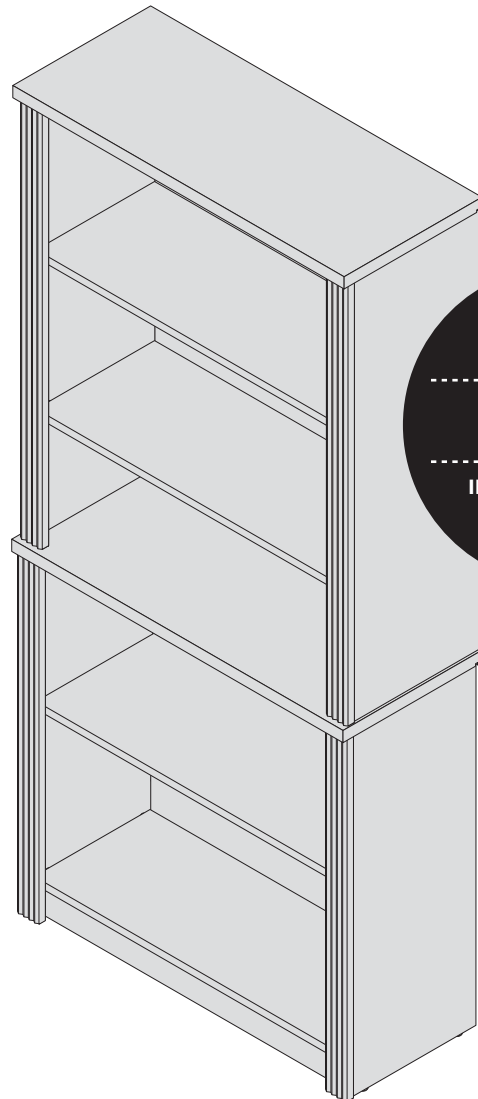



**PARTS / PIÈCES / PIEZAS**

CODE / CÓDIGO	QTY / QTÉ / CANT.	CODE / CÓDIGO	QTY / QTÉ / CANT.	CODE / CÓDIGO	QTY / QTÉ / CANT.	CODE / CÓDIGO	QTY / QTÉ / CANT.
30	1	40	1	HC42E	2	HC71E 13" x 29 1/4" (330 mm x 742 mm)	2
31	1	41	1	HC70E	2	80 29 1/8" (740 mm)	2
32	1	BB41B	1	BB80B	1	81 35 7/16" (900 mm)	2
33	1	HC41E	1	BB71B 17 1/8" x 29 1/4" (436 mm x 742 mm)	1		



**two people are required to assemble and move this model.**

deux personnes sont requises pour assembler et déplacer ce modèle.  
se necesitan dos personas para ensamblar y desplazar este mueble.

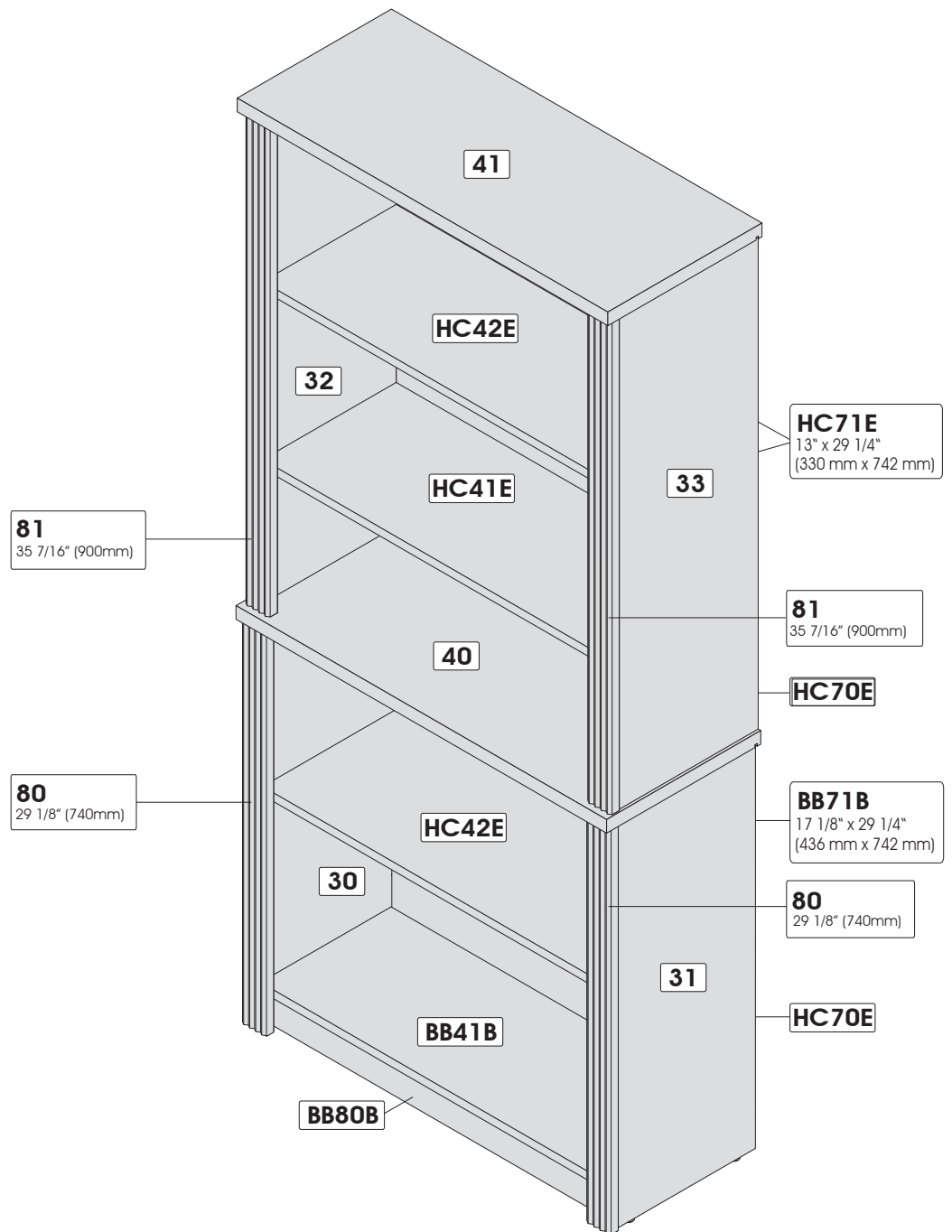

**HARDWARE / QUINCAILLERIES / QUINCALLA**

CODE / CÓDIGO	QTY / QTÉ / CANT.	CODE / CÓDIGO	QTY / QTÉ / CANT.	CODE / CÓDIGO	QTY / QTÉ / CANT.	CODE / CÓDIGO	QTY / QTÉ / CANT.
CA-99	26	H-03	30	RU-773	3	TI-552	2
CA-100	2	H-36	30	ST-614	8		
GO-88	2	PA-844	4	ST-760	1		
		RU-420	2	TI-365	8		

**REAL SIZE / GRANDEUR RÉELLE / TAMAÑO REAL**

CODE / CÓDIGO	QTY / QTÉ / CANT.
VC-204	2
VP-217	8

**PROBLEMS OR INFORMATION**

POUR TOUT PROBLÈME OU INFORMATION  
PROBLEMAS O INFORMACIÓN

**www.bestar.ca**  
**1888 823-7827**

**IMPORTANT NOTICE / NOTE IMPORTANTE / NOTA IMPORTANTE**

**H-03**

arrow  
flèche  
flecha

**Insert the cam with the arrow pointing towards the hole in the edge.**  
Insérez la rondelle en pointant la flèche vers le trou de la bordure.  
Inserte la arandela con la flecha apuntando hacia el orificio cercano al borde.

**Main hardware system / Système de quincaillerie principal / Sistema principal de quincalla**

**1** insert  
insérez  
insertar

**2** tools required  
outils requis  
herramientas necesarias

**3** tighten  
serrez  
apretar

**important**  
importante

**How to remove a misplaced assembly bolt (H-36).**  
Comment retirer un boulon (H-36) mal situé.  
Cómo retirar un perno (H-36) mal ubicado.

**A** turn  
tournez  
haga girar

**B** pull out  
retirez  
retire

**SERVICE/SERVICIO: 1-888 8BESTAR (1-888 823-7827)**

# ▶ IMPORTANT NOTICE / NOTE IMPORTANTE / NOTA IMPORTANTE

Duly complete the self-adhesive sticker. / Assurez-vous de bien remplir l'autocollant. / Asegúrese de completar correctamente la etiqueta.

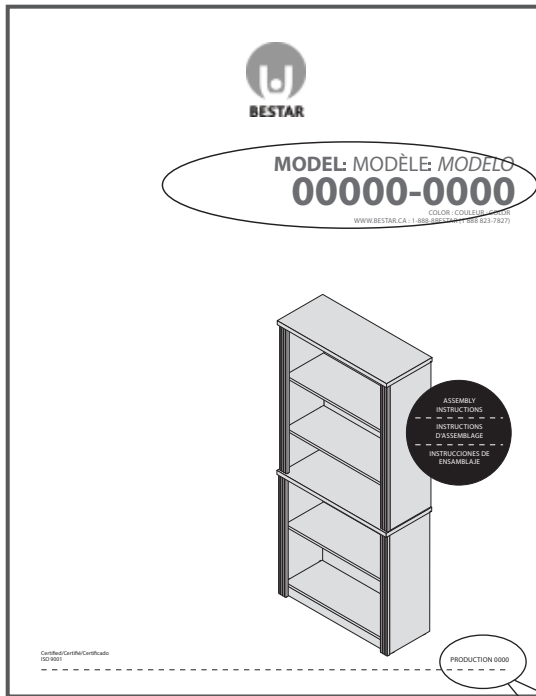

PRODUCTION 0000

  
**BESTAR**

**To better serve you!**  
Pour mieux vous servir!

**Model / Modèle:** \_\_\_\_\_

**Production Number**  
Numéro de production: \_\_\_\_\_

**Customer Service**  
Service à la clientèle **1-888-823-7827**

**Important/Importante**

**Please retain the self-adhesive sticker which you will find at step 12 of the instruction manual.**

Conservez l'autocollant qui sera collé seulement à l'étape 12 du feuillet d'instructions.



Conserve la etiqueta que será pegada sólo en la etapa 12 de la hoja de instrucciones.

# 1 HARDWARE INSTALLATION / INSTALLATION DES QUINCAILLERIES / INSTALACIÓN DE LAS QUINCALLAS

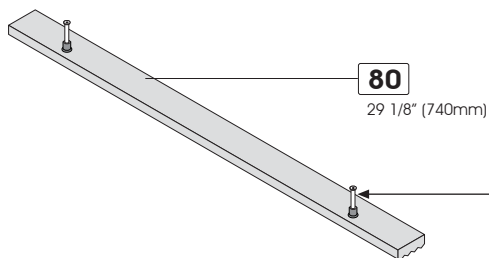
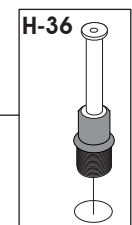
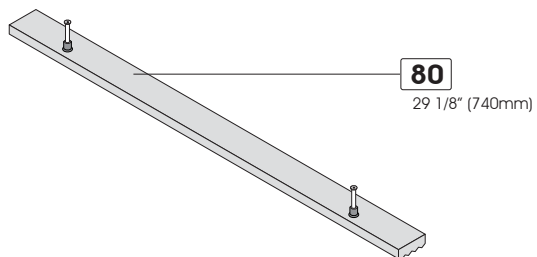
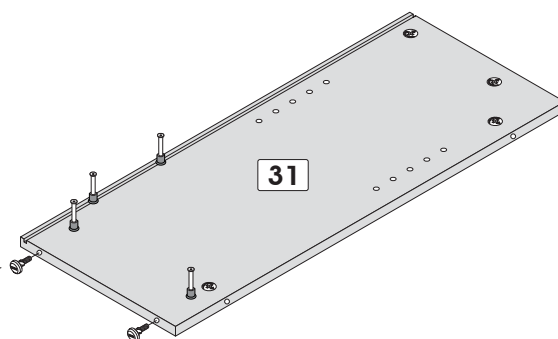
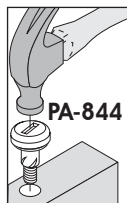
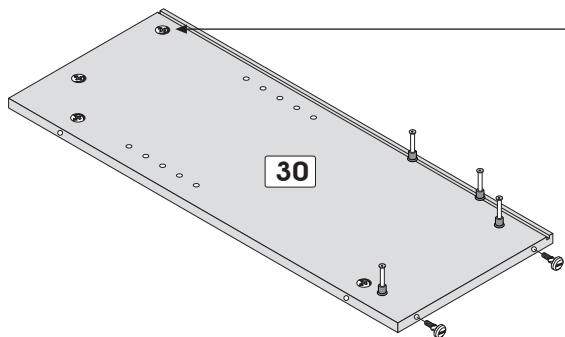
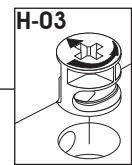
Modular Bookcase / Bibliothèque modulaire / Biblioteca modular

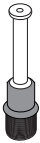

1

			
Code / Código	H-03	H-36	PA-844
Qty / Qté / Cant.	x 8	x 12	x 4

SERVICE/SERVICIO: 1-888 8BESTAR (1-888 823-7827)

# 2 HARDWARE INSTALLATION / INSTALLATION DES QUINCAILLERIES / INSTALACIÓN DE LAS QUINCALLAS

Modular Bookcase / Bibliothèque modulaire / Biblioteca modular

**TI-552**

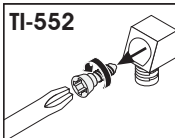

remove the screws to be used in step 3.  
enlever les vis qui serviront à l'étape 3.  
sacar los tornillos que servirá para la etapa 3.

insert  
insérer  
insertar

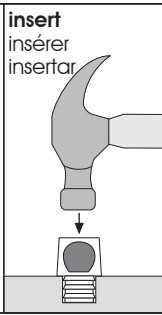
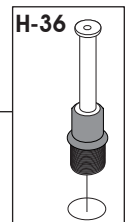
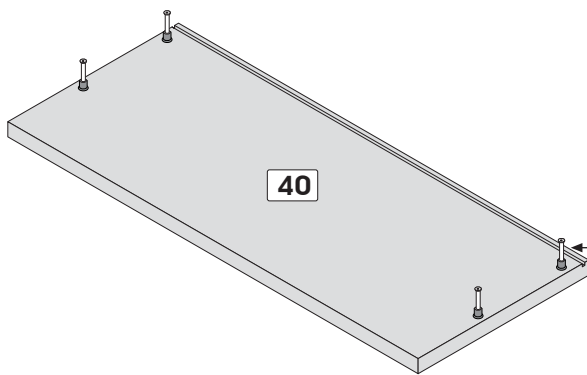
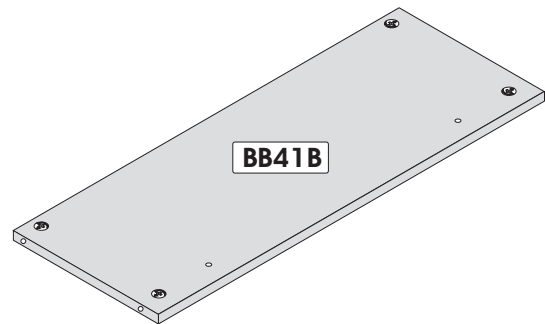
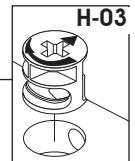
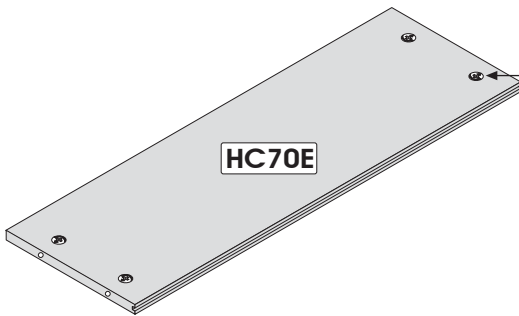
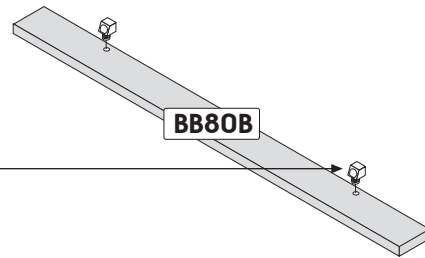
2

Code / Código

H-03

H-36

TI-552

Qty / Qté / Cant.

x 8

x 4

x 2

SERVICE/SERVICIO: 1-888 8BESTAR (1-888 823-7827)

Modular Bookcase / Bibliothèque modulaire / Biblioteca modular

**Assembling sequence**

Séquence d'assemblage

Secuencia de ensamblaje

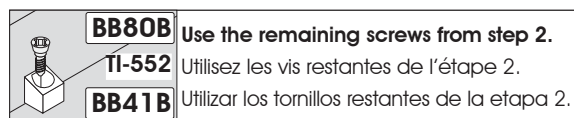
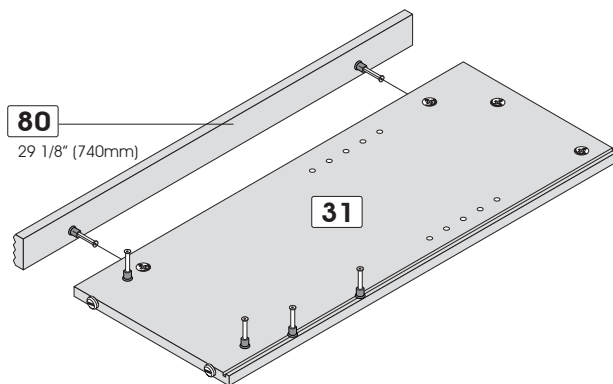
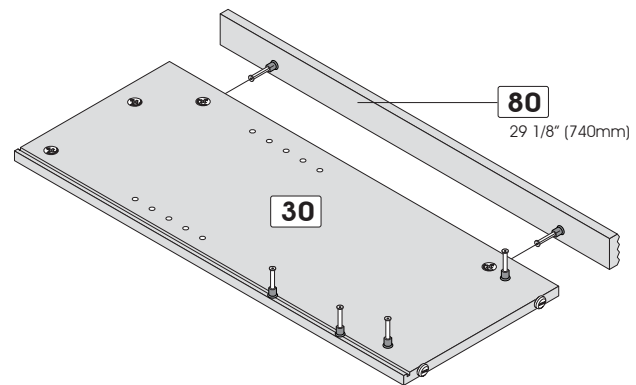
**Parts / Pièces / Piezas:****30** + **80** 29 1/8" (740mm)**31** + **80** 29 1/8" (740mm)**BB41B** + **BB80B****BB80B** Use the remaining screws from step 2.**TI-552** Utilisez les vis restantes de l'étape 2.**BB41B** Utilizar los tornillos restantes de la etapa 2.



**Assemble on the back edge**

Assemblez sur la bordure arrière

Realice el ensamblaje junto sobre el borde de atrás

**Assembling sequence**

Séquence d'assemblage

Secuencia de ensamblaje

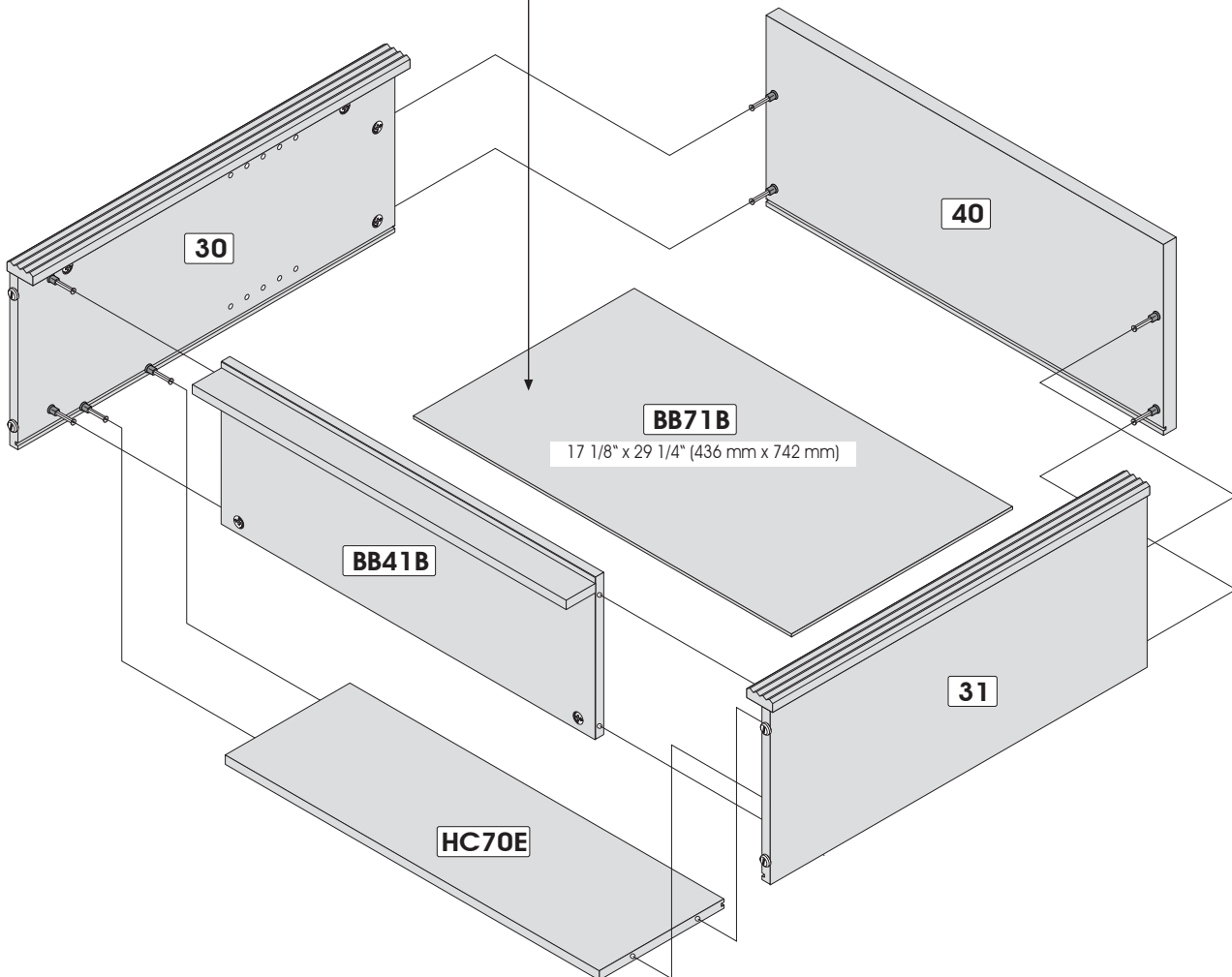
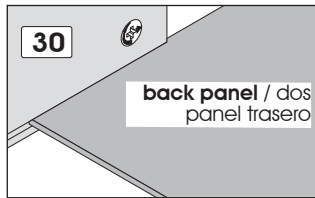
**Parts / Pièces / Piezas:****HC70E** **30** **BB41B** **31**+ **BB71B** 17 1/8" x 29 1/4" (436 mm x 742 mm) + **40**

**two people are required to assemble and move this model.**

deux personnes sont requises pour assembler et déplacer ce modèle.  
se necesitan dos personas para ensamblar y desplazar este mueble.

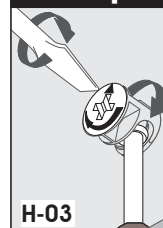
**Important/Importante**

**Remember to tighten the H-03 located on the back panel.**

N'oubliez pas de serrer les H-03 qui sont situées au dos.

No se olvide de apretar las H-03 que se encuentran en el panel trasero.

# 5 HARDWARE INSTALLATION / INSTALLATION DES QUINCAILLERIES / INSTALACIÓN DE LAS QUINCALLAS

Modular Bookcase / Bibliothèque modulaire / Biblioteca modular

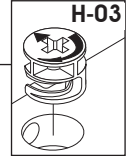
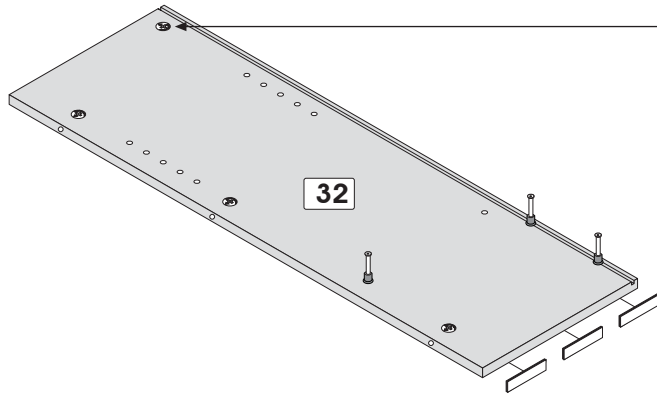

**Important/Importante**

**RU-420** Remove paper on one side only of RU-420.  
Retirez le papier sur seulement une des faces du RU-420.  
Retire el papel de sólo uno de los costados del RU-420.

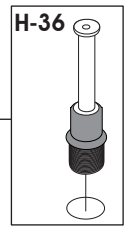
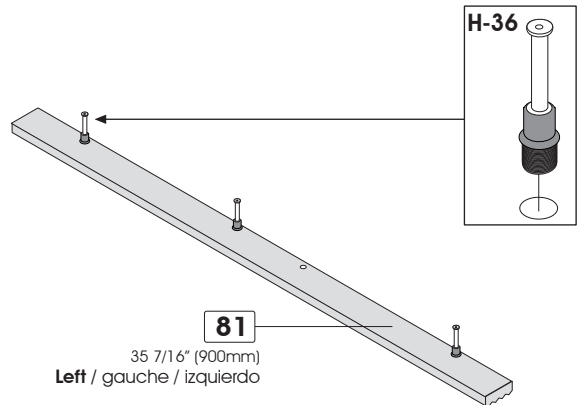
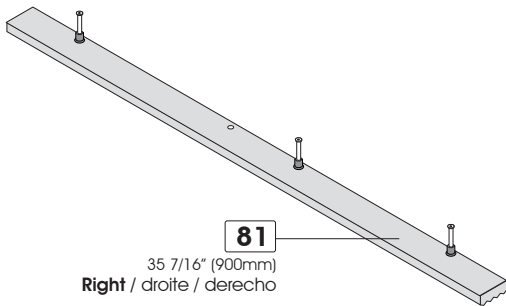
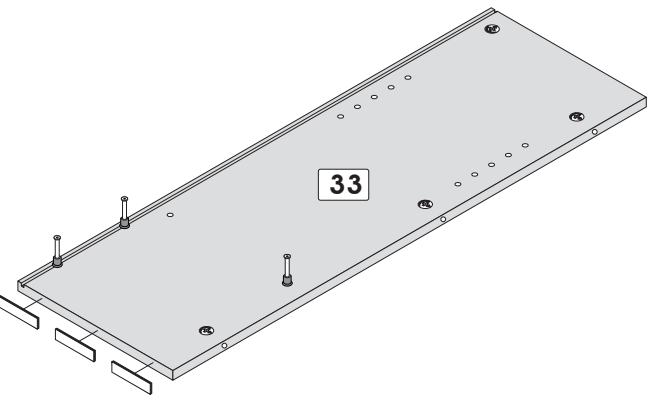

5

Code / Código	H-03	H-36	RU-420
Qty / Qté / Cant.	x 8	x 12	x 2

SERVICE/SERVICIO: 1-888 8BESTAR (1-888 823-7827)

# 6 HARDWARE INSTALLATION / INSTALLATION DES QUINCAILLERIES / INSTALACIÓN DE LAS QUINCALLAS

Modular Bookcase / Bibliothèque modulaire / Biblioteca modular

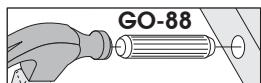
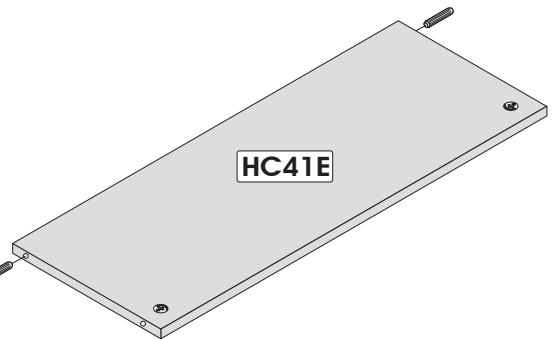
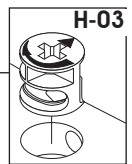
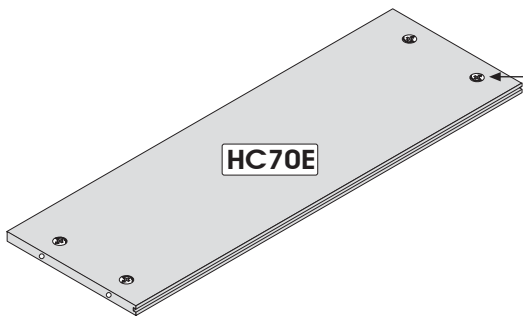
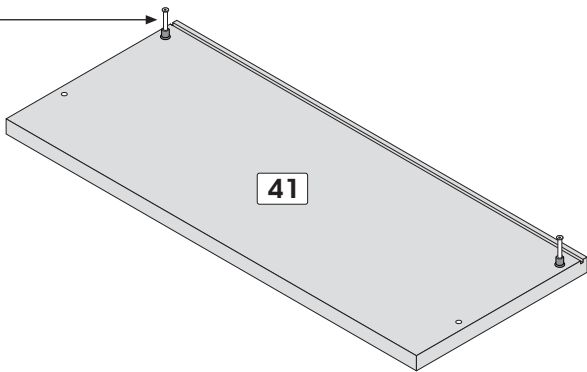
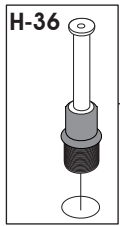

6



H-03

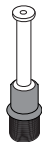

H-36

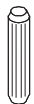

GO-88

Code / Código

Qty / Qté / Cant.

x 6

x 2

x 2

**Assembling sequence**  
 Séquence d'assemblage  
 Secuencia de ensamblaje  
**Parts / Pièces / Piezas:**

- 33** + **81** 35 7/16" (900mm)  
**Right / droite / derecho**
- 32** + **81** 35 7/16" (900mm)  
**Left / gauche / izquierdo**

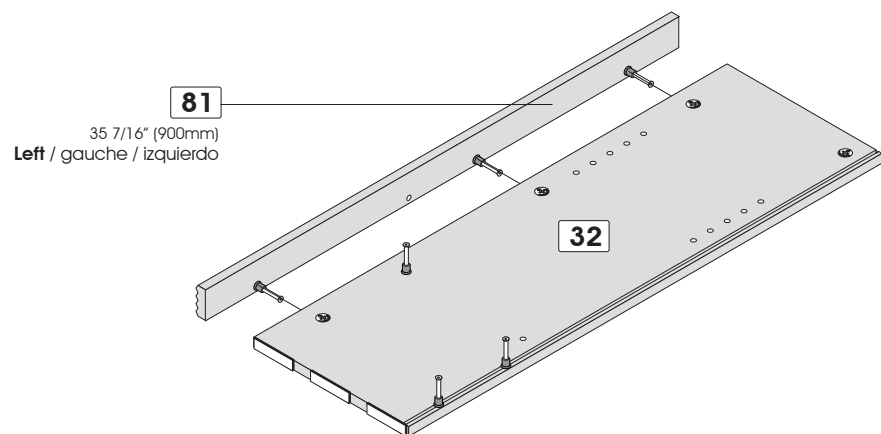
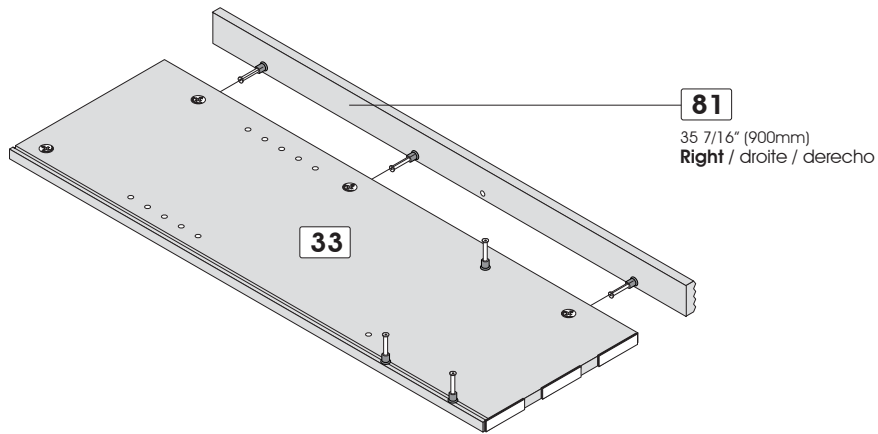



**two people are required to assemble and move this model.**  
 deux personnes sont requises pour assembler et déplacer ce modèle.  
 se necesitan dos personas para ensamblar y desplazar este mueble.

**Assemble on the back edge**

Assemblez sur la bordure arrière

Realice el ensamblaje junto sobre el borde de atrás

**Assembling sequence**

Séquence d'assemblage

Secuencia de ensamblaje

Parts / Pièces / Piezas:

**HC70E 32 HC41E 33**

+ **HC71E** 13" x 29 1/4" (330 mm x 742 mm) + **41**

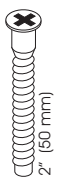
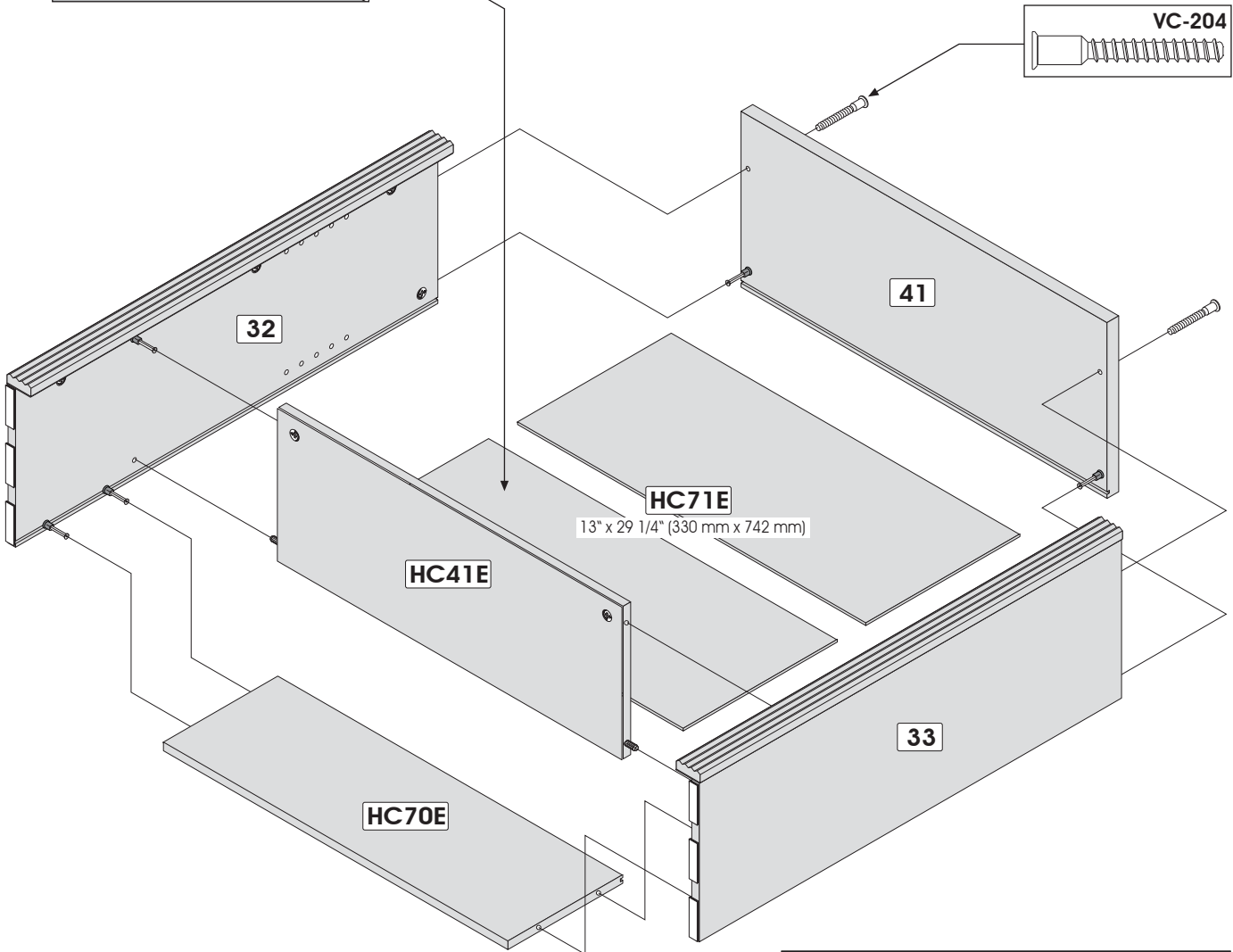
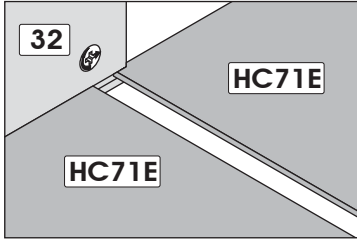

VC-204

Code / Código

Qty / Qté / Cant.

x 2

**Important/Importante**

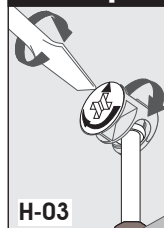

**Remember to tighten the H-03 located on the back panel.**

N'oubliez pas de serrer les H-03 qui sont situées au dos.

No se olvide de apretar las H-03 que se encuentran en el panel trasero.

H-03

**Important / Importante****RU-420**

**Remove paper from RU-420.**  
 Retirez le papier du RU-420.  
 Retire el papel del RU-420.

**A Depth alignment: Align the back of the hutch with the back of the bookcase.**

Alignement en profondeur : Aligner l'arrière de la huche avec l'arrière de la bibliothèque.

Alineamiento en profundidad : Alinear la parte posterior de la estantería con la parte posterior de la biblioteca.

**B Width alignment: Align side panels 32 and 33 of the hutch with the side panels of the bookcase.**

Alignement en largeur : Aligner les côtés 32 et 33 de la huche avec les côtés de la bibliothèque.

Alineamiento de ancho : Alinear los costados 32 y 33 de la estantería con los costados de la biblioteca.



**two people are required to assemble and move this model.**

deux personnes sont requises pour assembler et déplacer ce modèle.  
 se necesitan dos personas para ensamblar y desplazar este mueble.

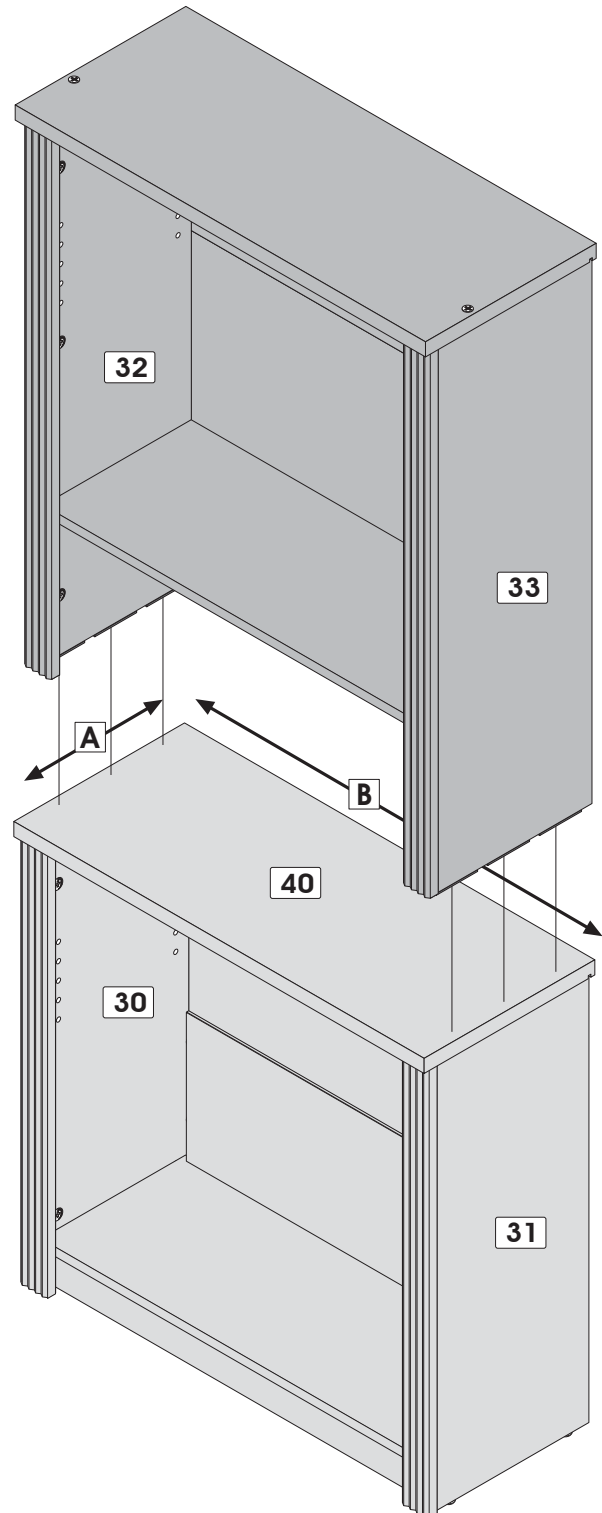
**Important/Importante**

**Move the furniture by its base.**

Déplacez le meuble par la base.

Desplace el mueble sosteniéndolo por la base

# 10 INSTALLATION / INSTALLATION / INSTALACIÓN

Modular Bookcase / Bibliothèque modulaire / Biblioteca modular

**Caution may tip / Attention risque de bascule / Precaución puede inclinarse**

ST-760

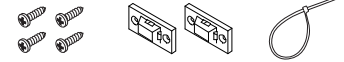

Please properly install the safety bracket following the directions provided on its hardware bag.

Veillez bien installer les ferronneries d'attaches selon les instructions fournies sur le sac de cette quincaillerie.

Instale los dispositivos de anclaje de acuerdo con las instrucciones de la bolsa de tornillería correspondiente.

**Important / Importante**

Remove paper from RU-773  
Retirez le papier du RU-773  
Retire el papel del RU-773

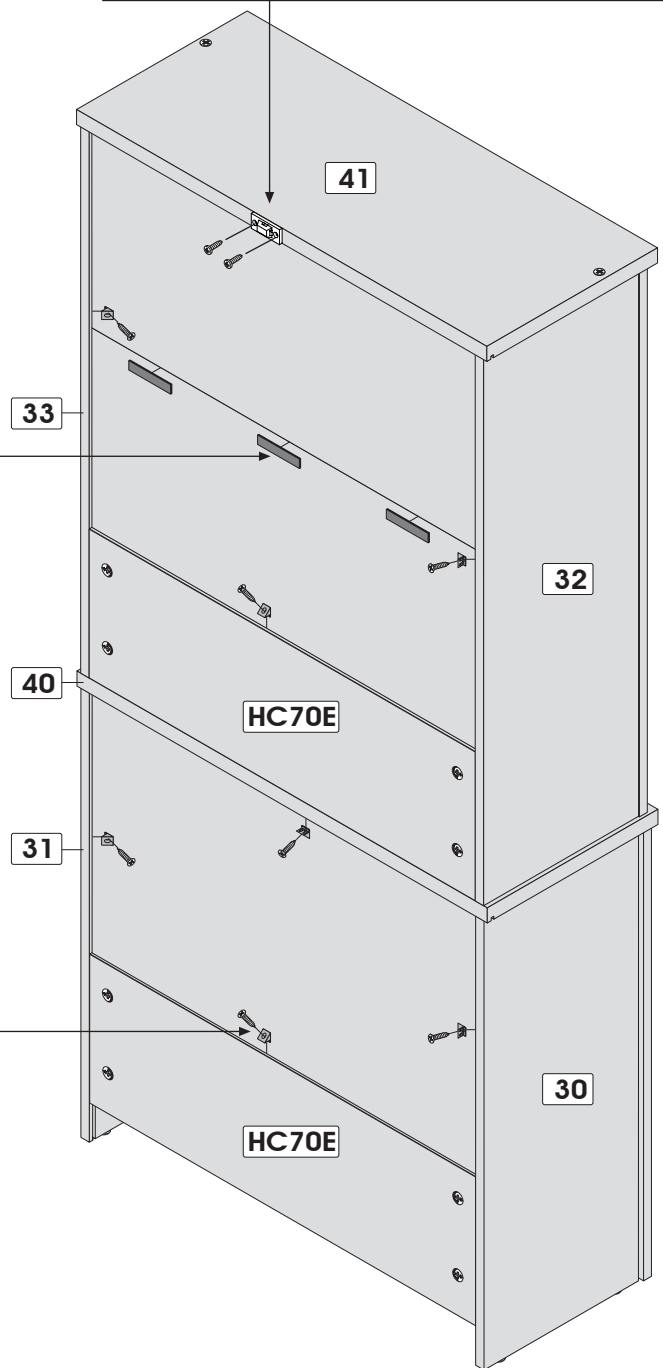
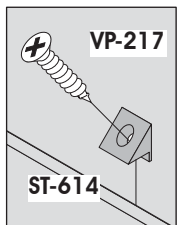
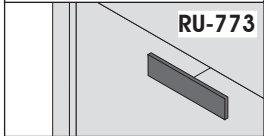

10

Code / Código

ST-614

RU-773

ST-760

VP-217

Qty / Qté / Cant.

x 8

x 3

x 1

x 8

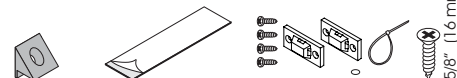

SERVICE/SERVICIO: 1-888 8BESTAR (1-888 823-7827)

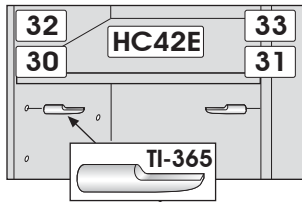

finished edge / bordure finie / borde acabado

finished edge / bordure finie / borde acabado

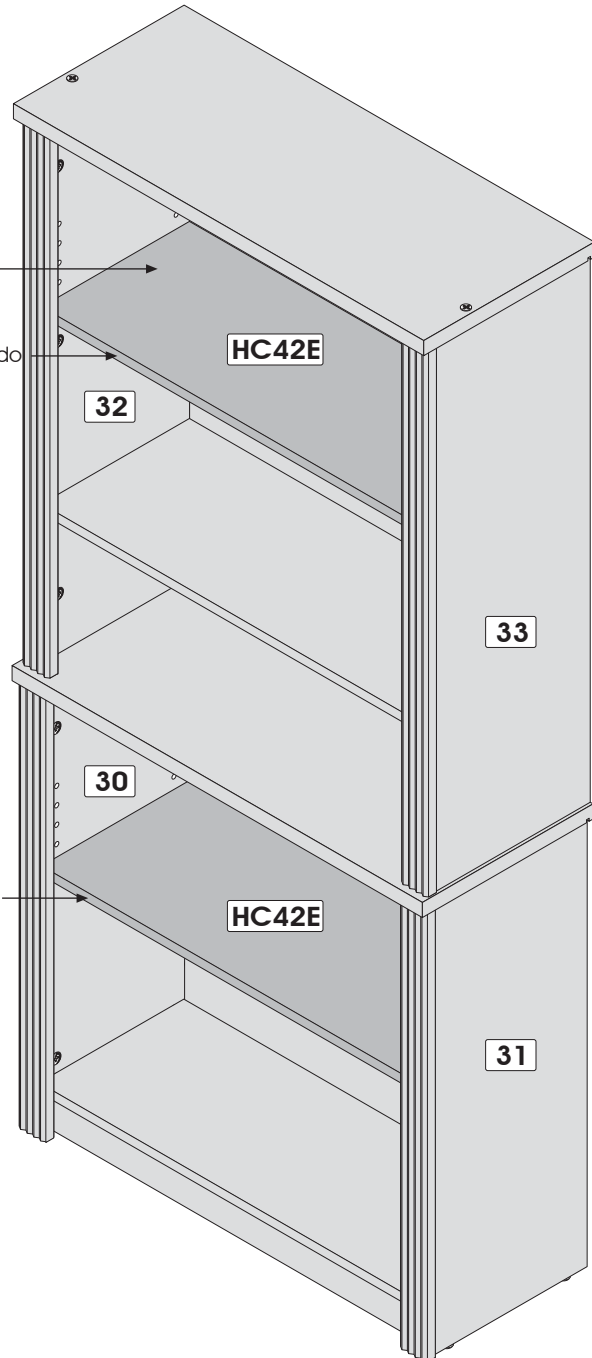

Code / Código      TI-365  
Qty / Qté / Cant.      x 8



**Important/Importante**

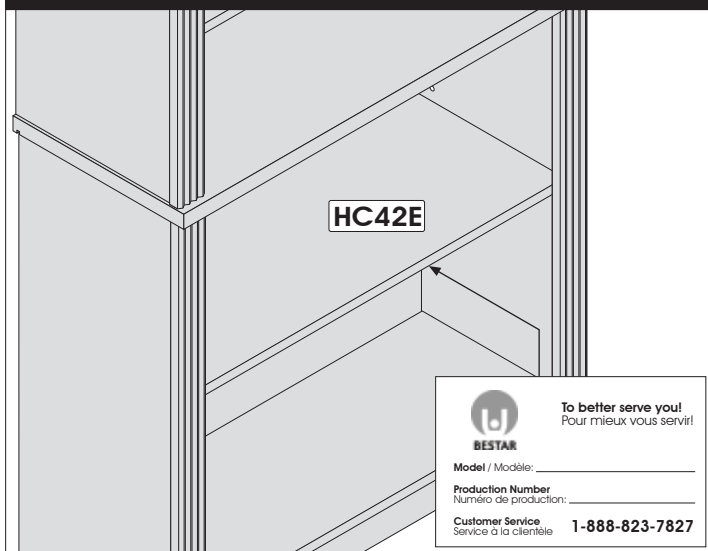

For future reference and to better serve you, please complete and apply the self-adhesive sticker in an accessible space such as under the part HC42E.

Pour mieux vous servir en cas de besoin, veuillez compléter et apposer l'autocollant dans un endroit facilement accessible tel que le dessous de la pièce HC42E.

Para futura referencia y mejor servicio por favor pegue la etiqueta en un lugar accesible, por ejemplo la parte inferior de la pieza HC42E.

**When you have completed the assembly of your new furniture, install plastic caps.**

Lorsque vous avez complété l'assemblage de votre meuble, installez les capuchons de plastique. Una vez que haya ensamblado el mueble, coloque los capuchones de plástico.

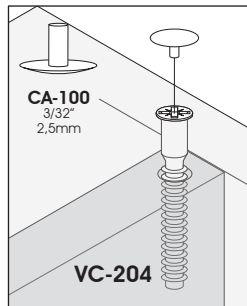
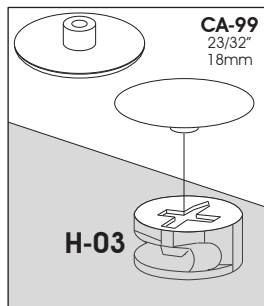

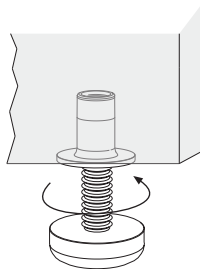

PA-844

**To level your furniture, use leg levelers.**

Pour niveler votre meuble utilisez les pattes ajustables.

Para nivelar su mueble utilice las patas ajustables.

**PRODUCT CARE / ENTRETIEN DU PRODUIT / MANTENIMIENTO DEL PRODUCTO**

**Avoid placing the furniture in the sunlight or near a source of heat. Use a soft dry cloth for dusting. To clean heavy dirt, use a cloth dipped in a solution of mild detergent and water. Avoid leaving wet objects on the surface or using commercial chemical cleaning products.**

Évitez d'exposer le meuble au soleil ou près de toute source de chaleur. Pour le nettoyage, utilisez un chiffon doux et sec. Pour la grosse saleté, utilisez un chiffon humidifié avec un peu de détergent dilué dans l'eau. Évitez de laisser des objets mouillés sur la surface de votre meuble ou d'utiliser des nettoyeurs chimiques.

Evite exponer el mueble al sol o las fuentes de calor. Para limpiarlo, utilice un paño suave y seco. Para limpiar las manchas rebeldes, utilice un trapo húmedo con un poco de detergente diluido en agua. No deje objetos mojados encima del mueble ni utilice limpiadores que contengan productos químicos.

**CONGRATULATIONS! YOU ARE NOW THE OWNER OF A QUALITY PRODUCT**  
FÉLICITATIONS! VOUS AVEZ MAINTENANT EN VOTRE POSSESSION UN PRODUIT DE QUALITÉ  
FELICITACIONES! AHORA ES USTED DUEÑO DE UN PRODUCTO DE CALIDAD.

**SERVICE/SERVICIO: 1-888 8BESTAR (1-888 823-7827)**





**For more information or to discover our new products**

Pour toute information ou pour découvrir nos nouveaux produits  
*Para obtener más información o para obtener nuevos productos*

**www.bestar.ca**



**FOR A LONG TIME**  
**POUR LONGTEMPS**  
*POR MUCHO TIEMPO*



**OUR FURNITURE IS GARANTEED FOR 10 YEARS. NO MATTER WHAT THE PROBLEM IS, OUR CUSTOMER SERVICE IS THERE FOR YOU.**

NOS MEUBLES SONT GARANTIS 10 ANS. PEU IMPORTE LE PROBLÈME, N'HÉSITÉZ PAS À COMMUNIQUER AVEC NOTRE SERVICE À LA CLIENTÈLE.

*NUESTROS MUEBLES TIENEN UNA GARANTIA DE 10 AÑOS. NO IMPORTA EL PROBLEMA, COMUNIQUE CON NUESTRO SERVICIO À CLIENTE.*

**WWW.BESTAR.CA : 1-88-8BESTAR (1-888-823-7827)**



**The new logo shows an open and radiant person. It also evokes BESTAR's past and the fact that we were the first manufacturer of ready-to-assemble furniture to design U-shaped furniture. Finally, if you take the logo in its simplest form, it shows that BESTAR is there for its employees, for its customers and for its consumers. "BESTAR is there for you (U)."**

Le nouveau logo illustre une personne ouverte et rayonnante. Il évoque également le passé de BESTAR qui fut le premier manufacturier de meubles prêt-à-assembler à concevoir des bureaux en forme de «U». Finalement, si on prend le logo sous sa forme la plus simple, il rappelle que BESTAR est présent pour ses employés, ses clients et ses consommateurs.

*El logotipo ilustra un personaje abierto y radiante. Élevoca igualmente, el pasado porque Bestar fue el primer fabricante de muebles listos para ensamblar a concebir escritorios en forma de "U". Finalmente, si tomamos el logotipo con su forma la más sencilla, nos recuerda que Bestar está presente para sus empleados, para sus clientes y para sus consumidores. "BESTAR está aquí para USTED (U)".*