

MODEL WC14349
WC14549
WC57449
WC64349
WC75749
WC84849
WC94449



Can we help you ?

THE BUSH FURNITURE

difference

- QUALITY
- INNOVATION
- SERVICE
- VALUE

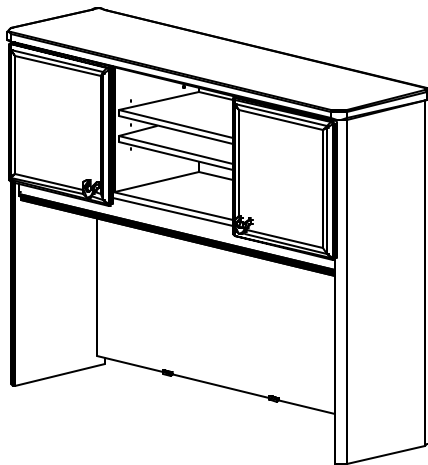

Bush
BUSINESS FURNITURE

Thank you for purchasing this Bush Business Furniture product. We trust that you will be completely satisfied with your product for many years to come. Bush Business Furniture products are backed by a 10 year warranty and crafted with today's styles in mind for the way you live.

Gracias por comprar este producto de Bush Business Furniture. Confiamos que usted estará completamente satisfecho con su mueble por muchos años. Productos de Bush Business Furniture tienen 10 años de garantía y son diseñados con los estilos de hoy en mente para la manera que usted vive.

Merci d'avoir acheté ce produit Furniture Business Bush. Nous comptons sur votre entière satisfaction avec votre produit au long des années à venir. Les produits furniture Business Bush sont garantis pour une période de 10 ans et sont conçus dans les styles d'aujourd'hui gardant à l'esprit votre mode de vie.

Sincerely,

Paul Bush

Paul Bush
President, Bush Industries



10 Year
WARRANTY

Bush™

BUSINESS FURNITURE



M - F 7a.m. - 11p.m.
Sat. 9a.m. - 5:30p.m.
Sun. 9a.m. - 5:30p.m.
(Except Holidays)

1-800-950-4782 USA/CANADA
95-800-950-4782 MEXICO
Se habla Español

Outside USA/ CANADA/ MEXICO:
001-716-665-2510 Ext. 5900

Email us:

ConsumerService@BushIndustries.com



www.bushfurniture.com

10 Year

WARRANTY

IT'S AS EASY AS 1,2,3

Assembly tips:

1. Read the instructions and become familiar with the parts.
2. To protect floors, assemble the furniture on the carton.
3. An assistant may be helpful.
4. Use of power tools is not recommended.

Consejos de Ensamblaje:

1. Lea las instrucciones y familiarícese con las partes.
2. Para proteger el piso, ensamble el mueble en el cartón.
3. Un asistente puede serle útil.
4. El uso de herramientas eléctricas no se recomienda.

Assemblage:

1. Lisez les instructions et familiarisez-vous avec les pièces.
2. Afin de protéger vos sols, assemblez votre meuble sur un carton.
3. Il sera peut-être utile de vous faire aider.
4. L'utilisation d'outils électriques n'est par recommandée.

CONSUMER SERVICE YOU CAN DEPEND ON

Questions? Operators are standing by at our TOLL FREE help line to assist you with assembly, and if necessary, quickly replace damaged/missing parts. Assistance is available all day every day. Simply have your store receipt, instruction manual, and part number/description ready when you call our TOLL FREE help line. It's that easy.

Servicio al consumidor en que usted puede depender

¿ Preguntas ? Operadores estan listos en nuestra LINEA DE ASISTENCIA GRATUITA para ayudarle con ensamblaje y si sea necesario reemplazo rápido de partes dañadas o que falten. Asistencia está disponible todo el día todos los días. Simplemente tenga listo su recibo de la tienda, la hoja de instrucciones, y número de parte/descripción cuando llame nuestra LINEA DE ASISTENCIA GRATUITA. Es así de fácil.

Vous pouvez compter sur notre service clientèle

des Questions? Nos opérateurs se tiennent à votre disposition, veuillez contacter notre NUMERO GRATUIT D'ASSISTANCE CLIENTS, où l'on vous portera assistance dans votre assemblage, et si nécessaire, pour le remplacement des pièces défectueuses ou manquantes. Cette assistance est disponible 24/24 et 7/7 jours. Quand vous appelez le NUMERO GRATUIT D'ASSISTANCE CLIENTS, veuillez simplement avoir à portée de main votre ticket d'achat, le manuel d'instructions et les références du modèle. C'est aussi simple que cela.



WARNING

This hutch is intended to be attached to base units that are interconnected in L-or U-shaped workstations. If the hutch is not attached to interconnected base units in this manner, then the combined units must be placed against a wall. Improper assembly or usage could cause instability, tip over, and/or serious injury.

Any questions, please call 1-888-592-0083.

Este gabinete ha sido diseñado para ser conectado a otras unidades de trabajo en forma de "L" o "U". Si este gabinete no está sujeto a unidades de bases interconectadas, las unidades combinadas siempre deben ser colocadas contra una pared. Si tiene preguntas con relación a este procedimiento, favor de llamar 1-888-592-0083

Ce vaisselier est supposé être attaché aux unités interconnectées, alors les unités assemblées doivent être mises contre un mur. Pour toutes questions, veuillez appeler le 1-888-592-0083.



WARNING

Do not move unit when loaded. Doing so could cause instability, product collapse, tip over, and/or serious injury.

No mueva la unidad cuando esté cargada. Hacerlo puede causar inestabilidad, que el producto se derrumbe, que se la caiga encima y/o heridas (golpes) serias.

Ne pas déplacer l'unité lorsqu'elle est chargée. Faire ainsi peut causer l'instabilité, l'effondrement ou le renversement du meuble et/ou des endommagements sérieux.

IMPORTANT SAFETY INFORMATION

EXPLODED VIEW

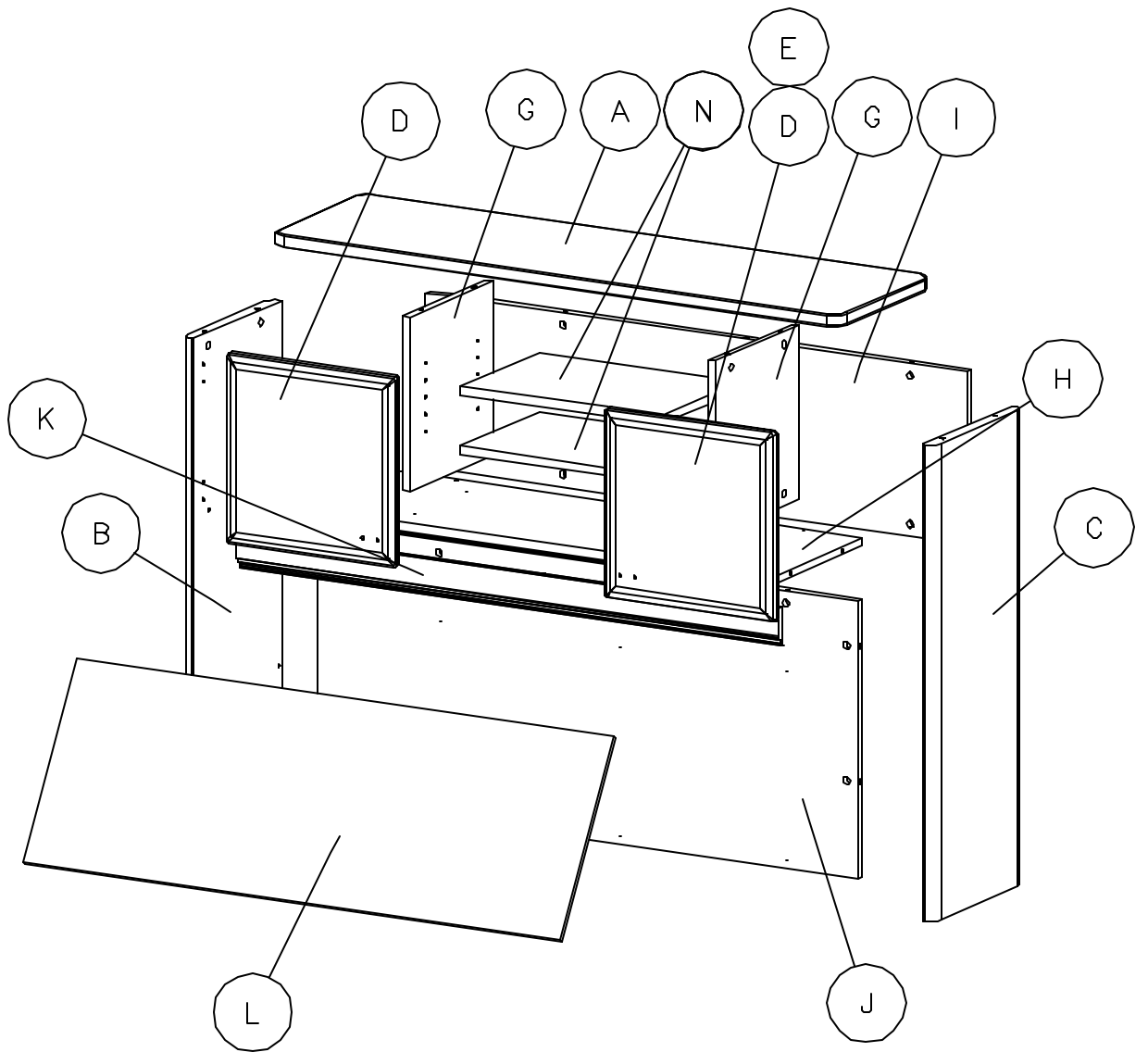
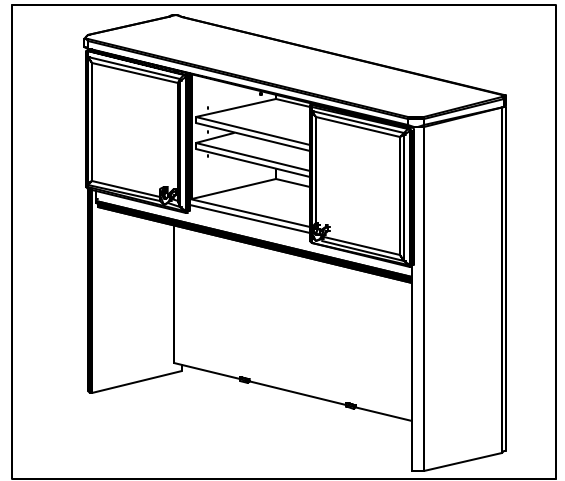

1
8
0
0
9
5
0
4
7
8
2



A139403

PARTS LIST

WC14349		
A	[1]	W133568
B	[1]	W88496
C	[1]	W88497
D	[2]	W88498
G	[2]	W125742
H	[1]	W133564
I	[1]	W133565
J	[1]	W133566
K	[1]	W133753
L	[1]	S125743
N	[2]	W88512

WC14549		
A	[1]	W133558
B	[1]	W82307
C	[1]	W82308
D	[1]	W82314
E	[1]	W82334
G	[2]	W125745
H	[1]	W133559
I	[1]	W133560
J	[1]	W133561
K	[1]	W133751
L	[1]	S125746
N	[2]	W82321

WC57449		
A	[1]	W133570
B	[1]	W88496
C	[1]	W88497
D	[2]	W93348
G	[2]	W125742
H	[1]	W133564
I	[1]	W133565
J	[1]	W133566
K	[1]	W133754
L	[1]	S125743
N	[2]	W88512

WC64349		
A	[1]	W133544
B	[1]	W130071
C	[1]	W130072
D	[2]	W130078
G	[2]	W130085
H	[1]	W133545
I	[1]	W133550
J	[1]	W133551
K	[1]	W133749
L	[1]	S130089
N	[2]	W130090

WC75749		
A	[1]	W133533
B	[1]	W83178
C	[1]	W83179
D	[1]	W83185
E	[1]	W83186
G	[2]	W125738
H	[1]	W133536
I	[1]	W133537
J	[1]	W133538
K	[1]	W133748
L	[1]	S125739
N	[2]	W83206

WC84849		
A	[1]	W133563
B	[1]	W88496
C	[1]	W88497
D	[2]	W104566
G	[2]	W125742
H	[1]	W133564
I	[1]	W133565
J	[1]	W133566
K	[1]	W133752
L	[1]	S125746
N	[2]	W88512

WC94449		
A	[1]	W133553
B	[1]	W98955
C	[1]	W98956
D	[2]	W98957
G	[2]	W125757
H	[1]	W133554
I	[1]	W133555
J	[1]	W133556
K	[1]	W133750
L	[1]	S125758
N	[2]	W98950

1
8
0
0
9
5
0
4
7
8
2



FASTENER LIST

H72988 Quantity 28

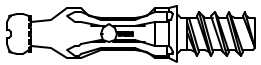

H71659 Quantity 28

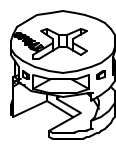

H38169 Quantity 4



8 x 30 mm

H35251 Quantity 10



10 x .5"

H28917 Quantity 8



#6 x 1/2"

H23491 Quantity 4



#10 x 2"

?
1
·
8
0
0
·
9
5
0
·
4
7
8
2



HARDWARE LIST

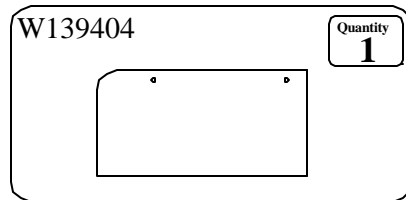
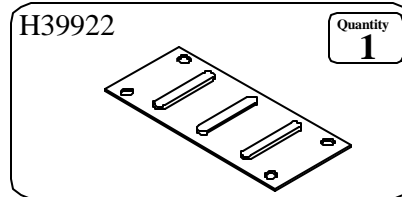
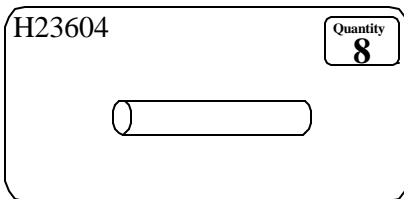
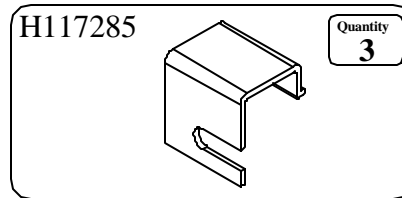
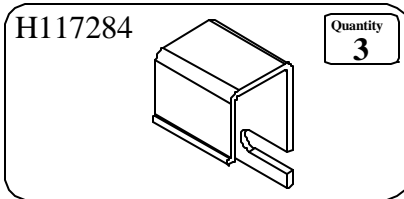
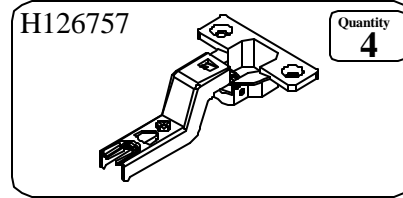
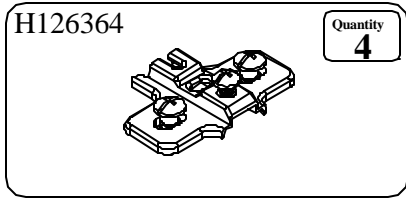
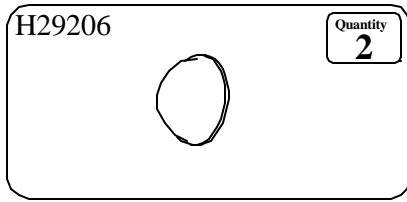

?

1

·

8

0

0

·

9

5

0

·

4

7

8

2

MODEL SPECIFIC HARDWARE

1
8
0
0
9
5
0
4
7
8
2

WC14349

H92521 Quantity **22**

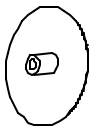

WC57449
WC84849

H97436 Quantity **22**

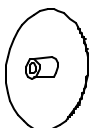

WC64349
WC14549

H83021 Quantity **22**

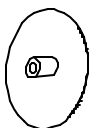

WC94449

H73621 Quantity **22**

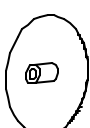

WC14549

H91373 Quantity **2**

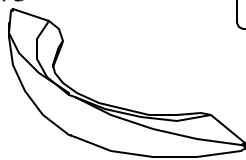

H92138 Quantity **4**



8 x 1.125"

WC75749

H77823 Quantity **22**

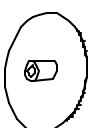

H83034 Quantity **2**

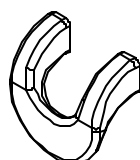

H83431 Quantity **4**

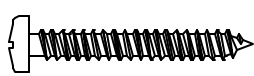

8 x 1.25



H72988

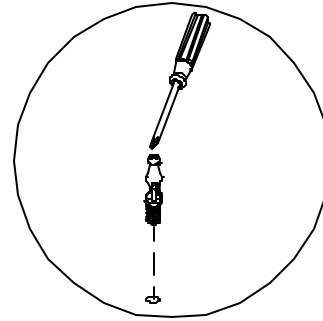

1

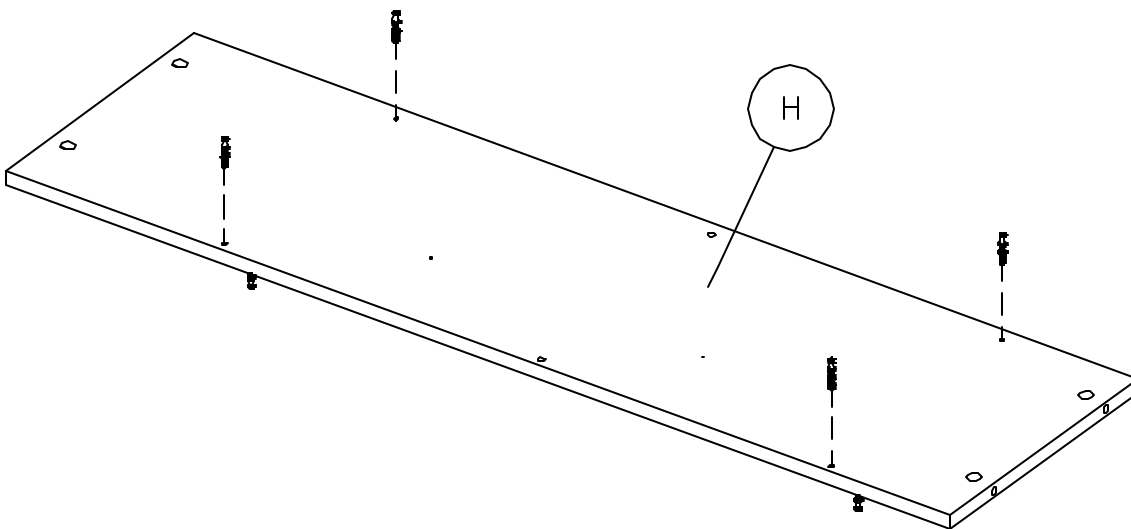
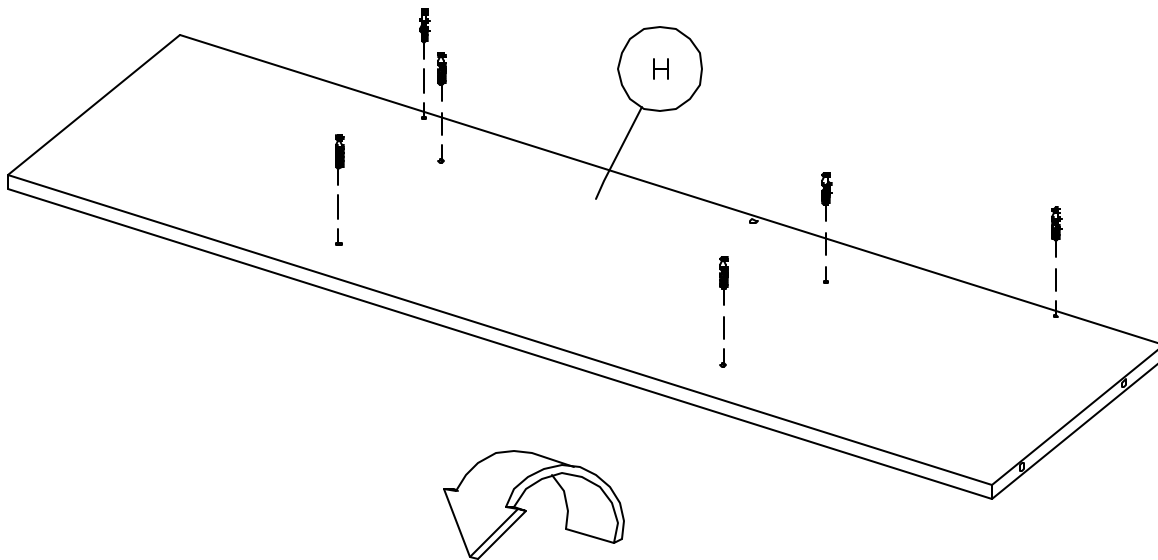

?

1
·
8
0
0
·
9
5
0
·
4
7
8
2

A139403



2

H38169



[2]

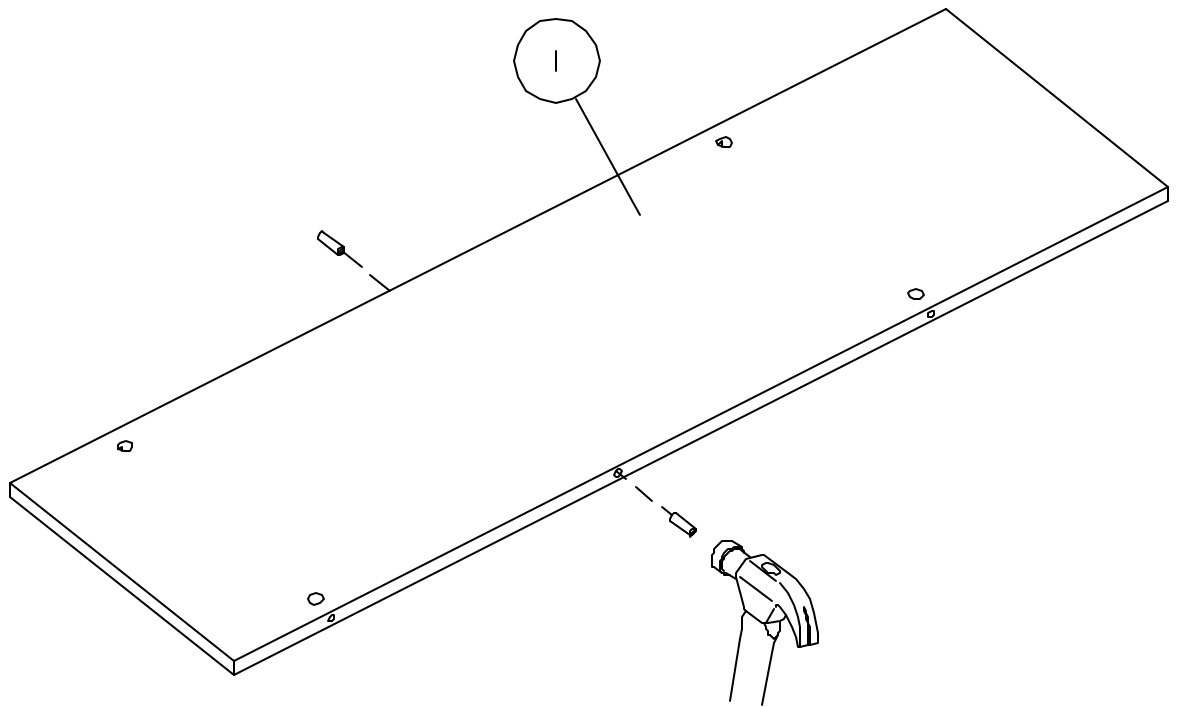

?

1
·
8
0
0
·
9
5
0
·
4
7
8
2



A139403

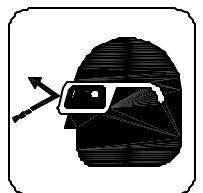



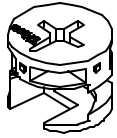

H71659

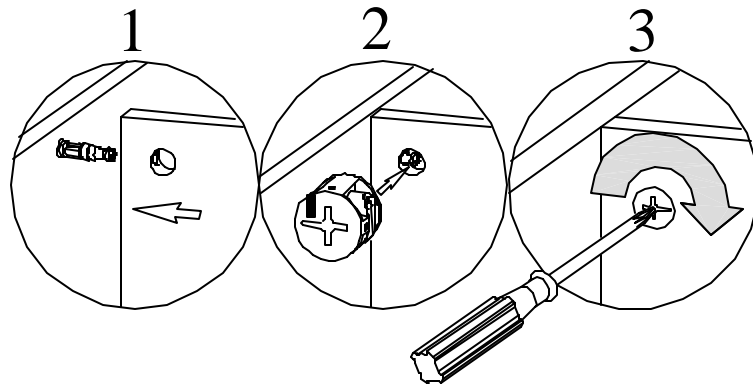

[2]



3

<p>WC14349</p> <p>H92521</p> <p>Quantity 2</p> 	<p>WC64349 WC14549</p> <p>H83021</p> <p>Quantity 2</p> 	
<p>WC57449 WC84849</p> <p>H97436</p> <p>Quantity 2</p> 	<p>WC94449</p> <p>H73621</p> <p>Quantity 2</p> 	<p>WC75749</p> <p>H77823</p> <p>Quantity 2</p> 

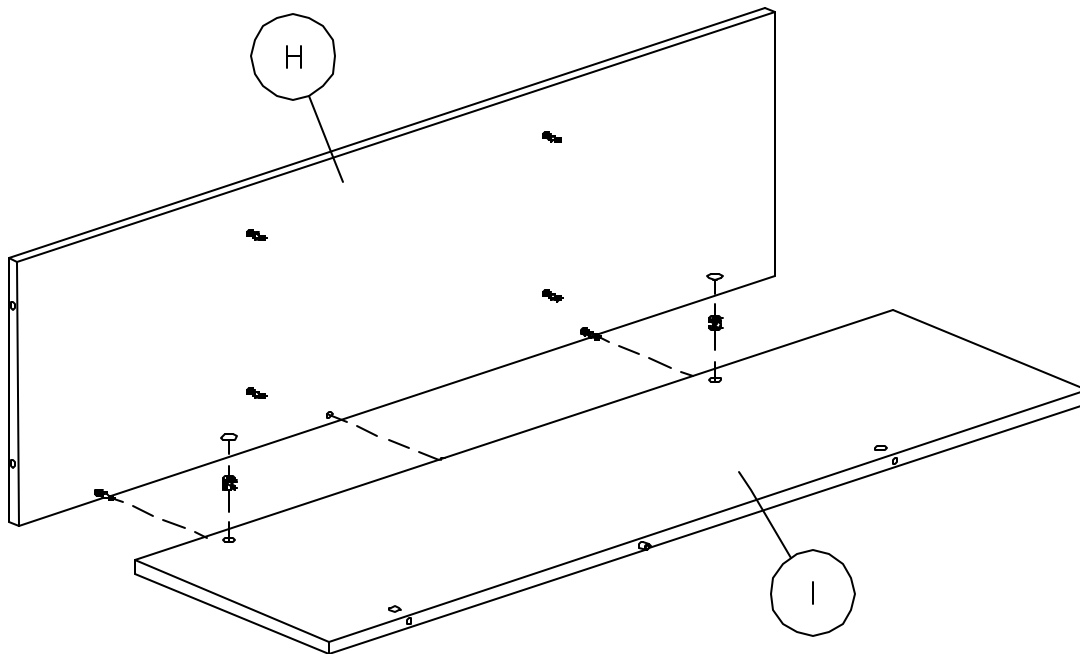

?
1
·
8
0
0
·
9
5
0
·
4
7
8
2



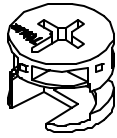

4

H71659

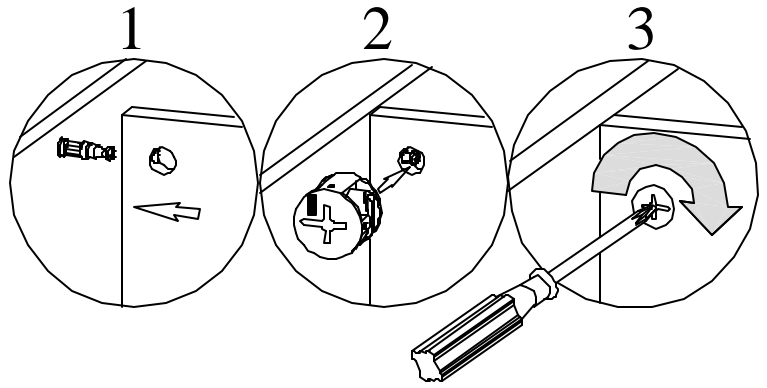

[4]



<p>WC14349</p> <p>H92521</p> <p>Quantity 4</p> 	<p>WC64349 WC14549</p> <p>H83021</p> <p>Quantity 4</p> 	
<p>WC57449 WC84849</p> <p>H97436</p> <p>Quantity 4</p> 	<p>WC94449</p> <p>H73621</p> <p>Quantity 4</p> 	<p>WC75749</p> <p>H77823</p> <p>Quantity 4</p> 

?

1
·
8
0
0
·
9
5
0
·
4
7
8
2

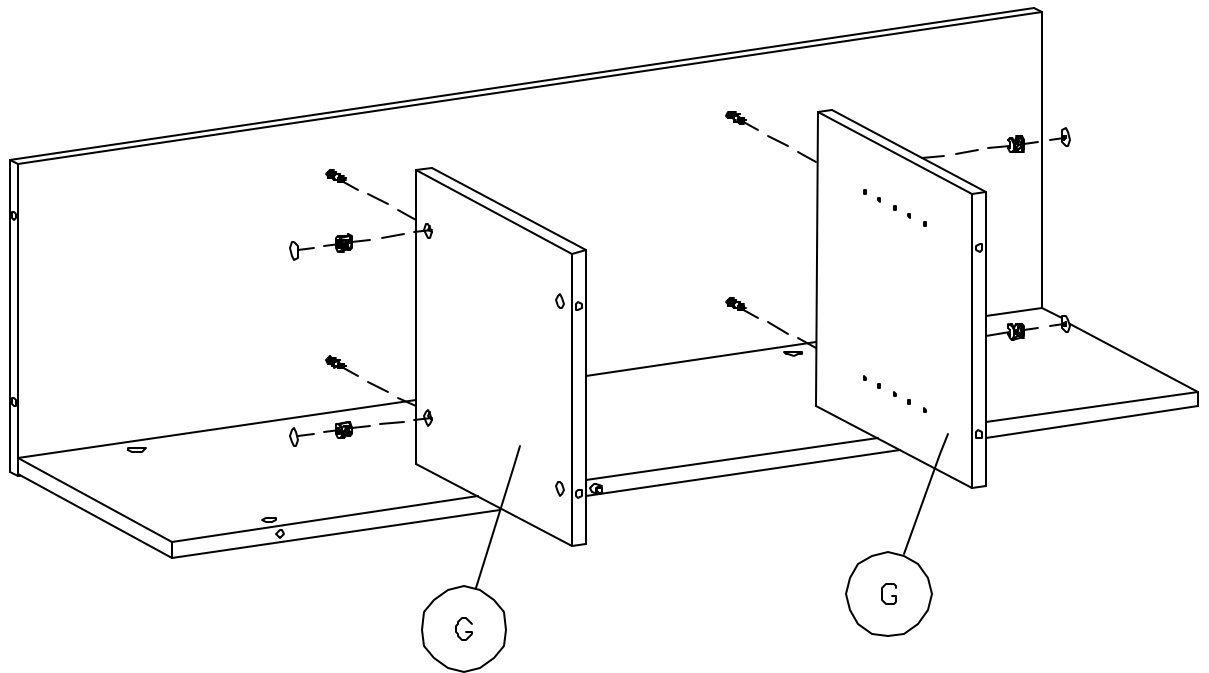

H38169



[1]

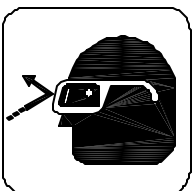
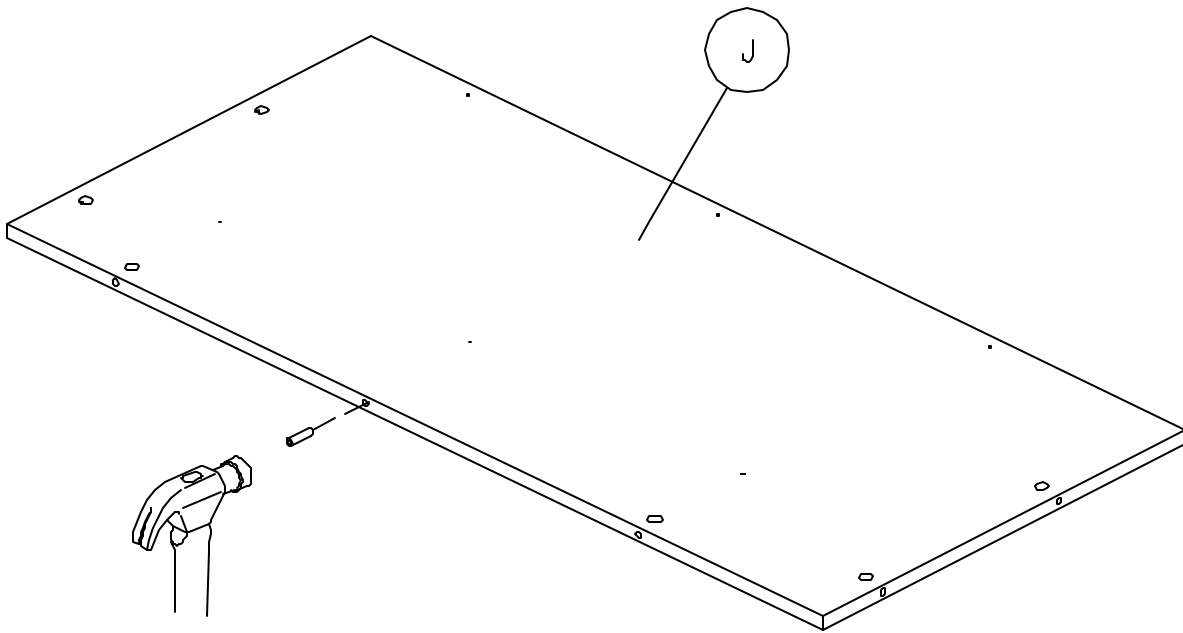

5

?
1
·
8
0
0
·
9
5
0
·
4
7
8
2

6

H71659

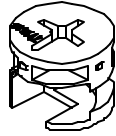

[2]

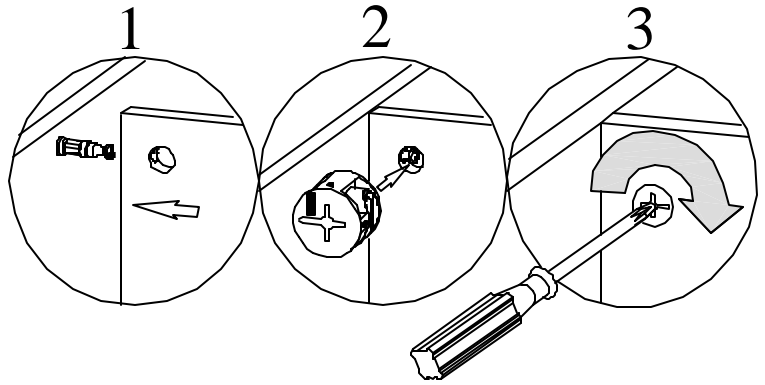

<p>WC14349</p> <p>H92521</p> <p>Quantity 2</p>	<p>WC64349 WC14549</p> <p>H83021</p> <p>Quantity 2</p>	
<p>WC57449 WC84849</p> <p>H97436</p> <p>Quantity 2</p>	<p>WC94449</p> <p>H73621</p> <p>Quantity 2</p>	<p>WC75749</p> <p>H77823</p> <p>Quantity 2</p>

?

1
·
8
0
0
·
9
5
0
·
4
7
8
2

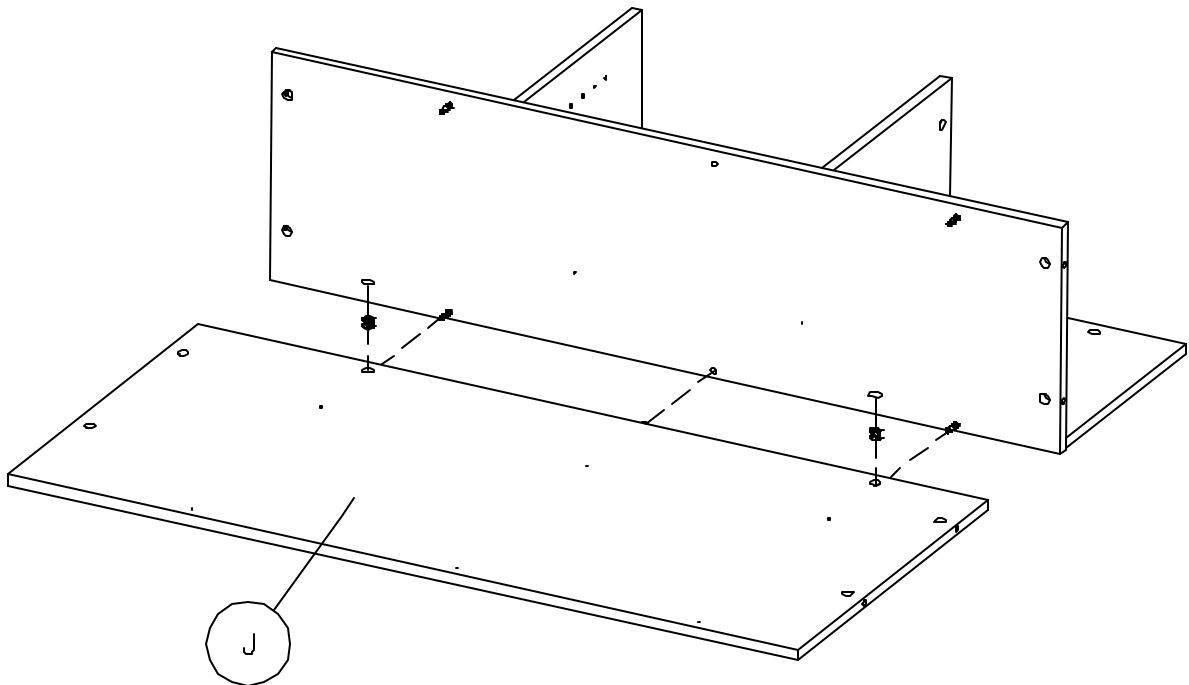

H72988 [4]

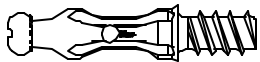

H126364 [2]

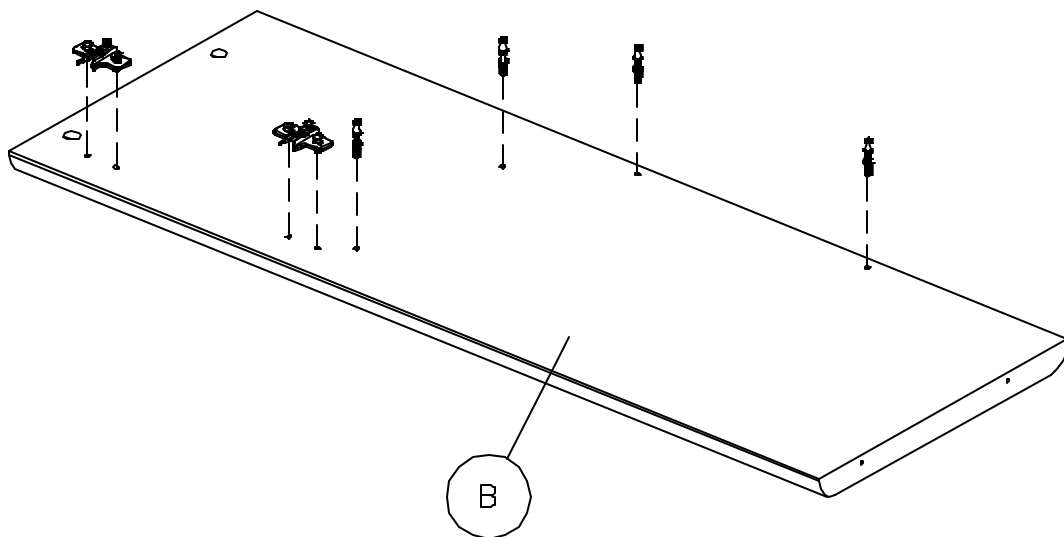
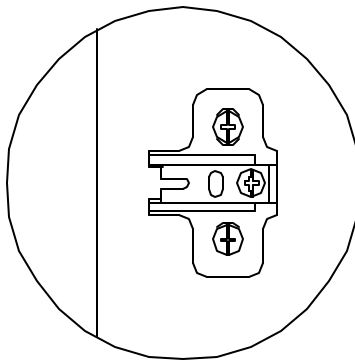
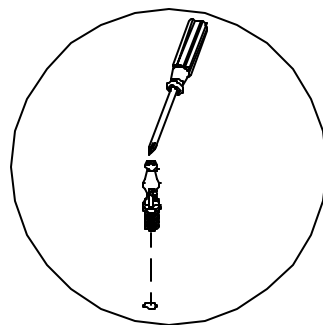
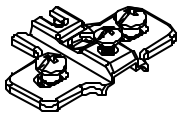

7

?



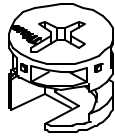

1
·
8
0
0
·
9
5
0
·
4
7
8
2

H71659

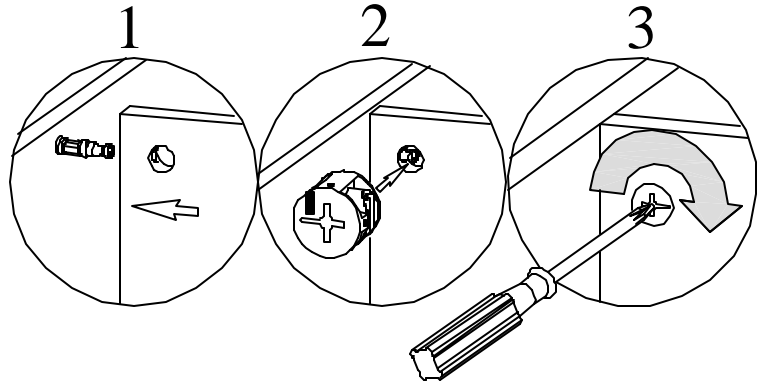

[4]



<p>WC14349</p> <p>H92521</p> <p>Quantity 2</p> 	<p>WC64349 WC14549</p> <p>H83021</p> <p>Quantity 2</p> 	
<p>WC57449 WC84849</p> <p>H97436</p> <p>Quantity 2</p> 	<p>WC94449</p> <p>H73621</p> <p>Quantity 2</p> 	<p>WC75749</p> <p>H77823</p> <p>Quantity 2</p> 

?
1
·
8
0
0
·
9
5
0
·
4
7
8
2

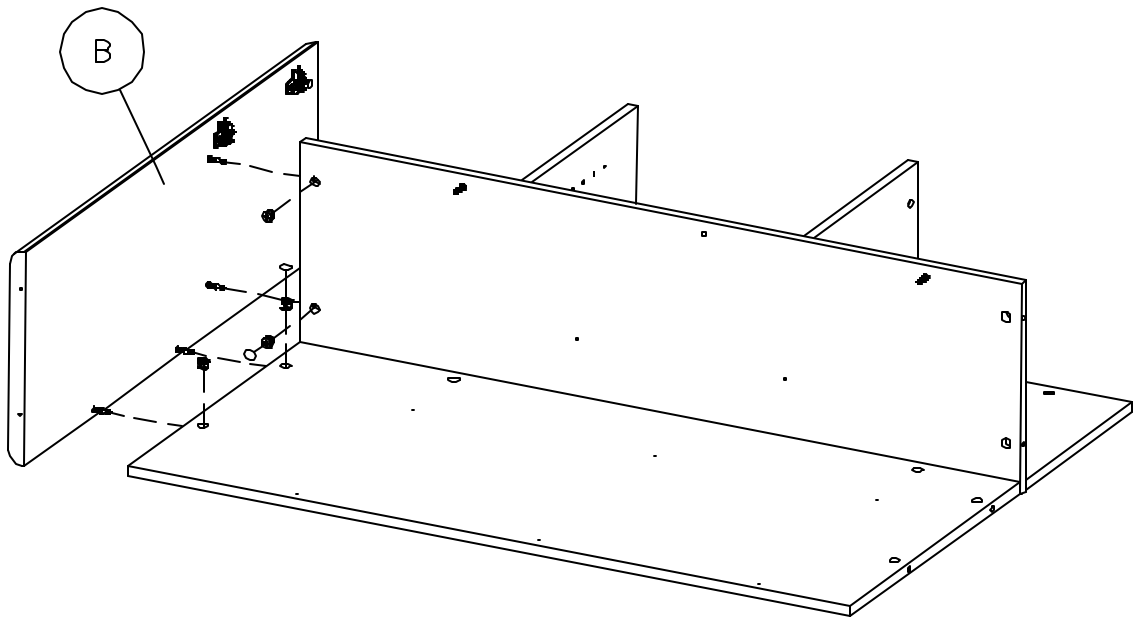

H72988 [4]

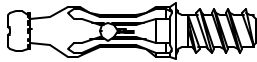

H126364 [2]

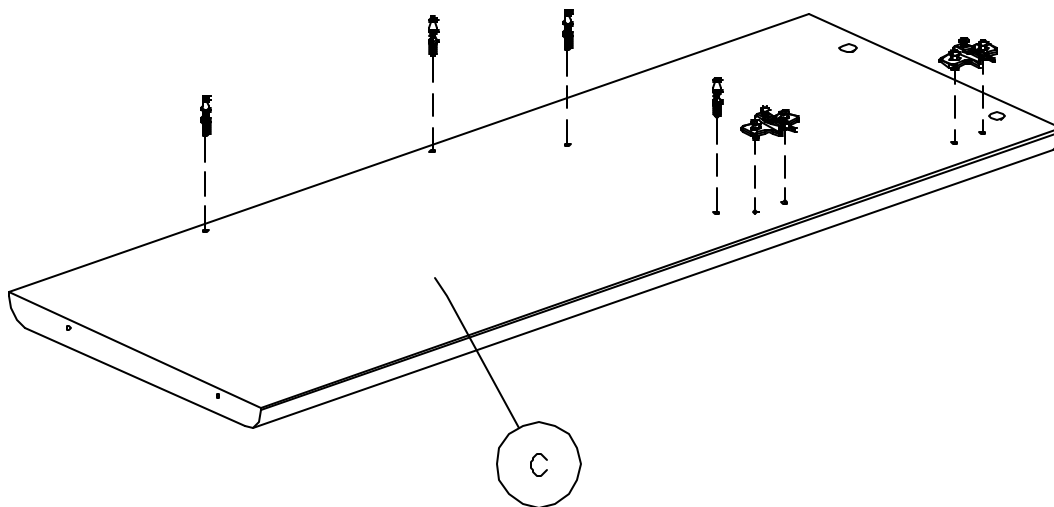
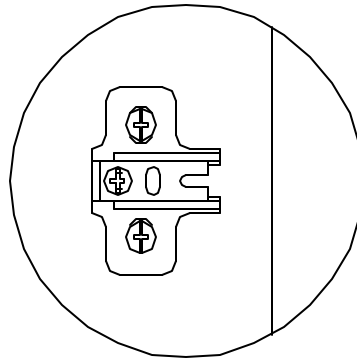
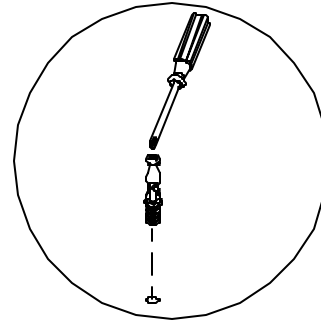
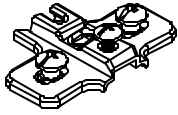

9

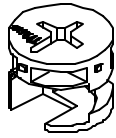

?
1
·
8
0
0
·
9
5
0
·
4
7
8
2

H71659

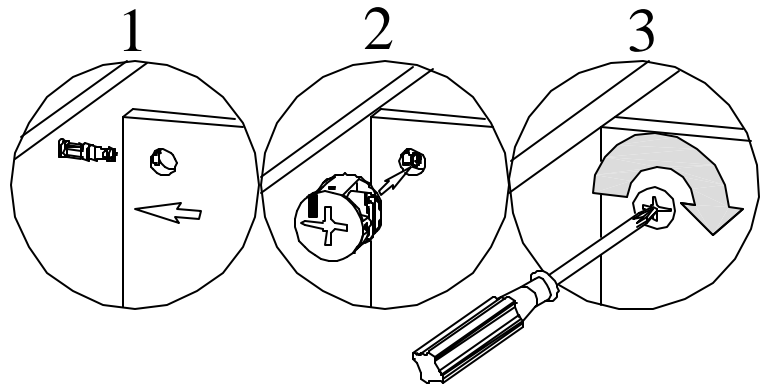

[4]

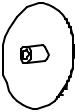
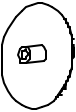
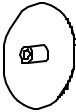

<p>WC14349</p> <p>H92521 Quantity 2</p> 	<p>WC64349 WC14549</p> <p>H83021 Quantity 2</p> 	
<p>WC57449 WC84849</p> <p>H97436 Quantity 2</p> 	<p>WC94449</p> <p>H73621 Quantity 2</p> 	<p>WC75749</p> <p>H77823 Quantity 2</p> 

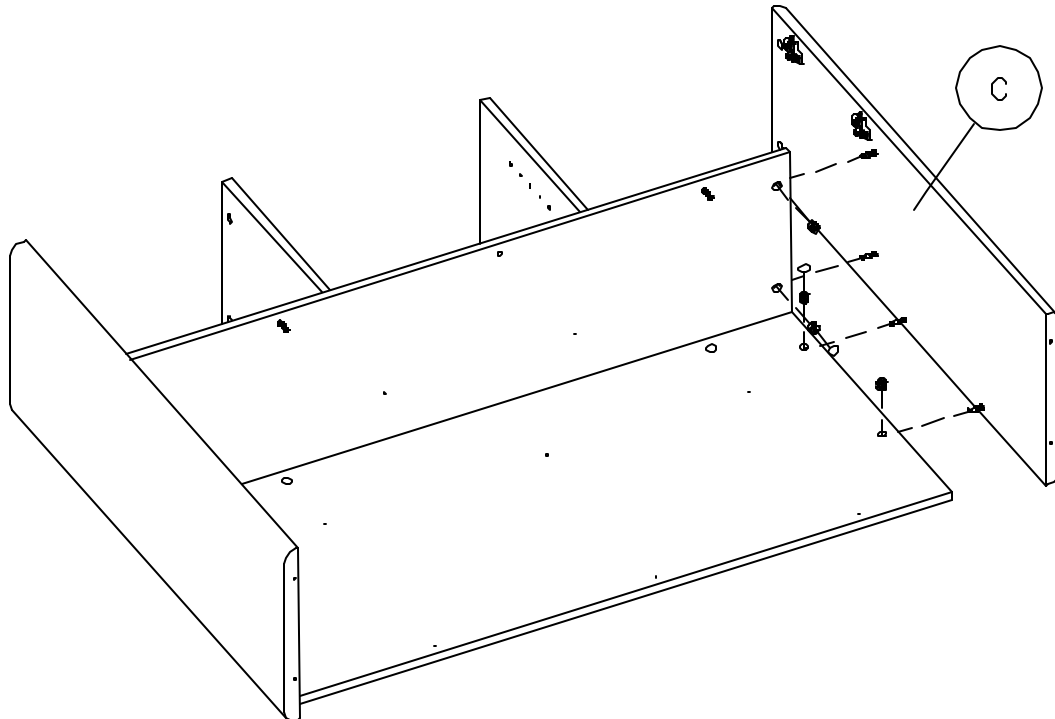

?
1
·
8
0
0
·
9
5
0
·
4
7
8
2



H72988

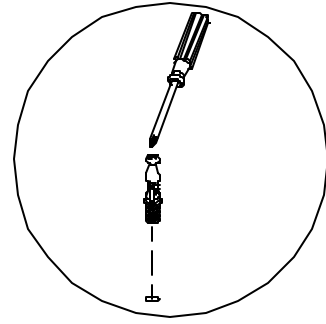

11

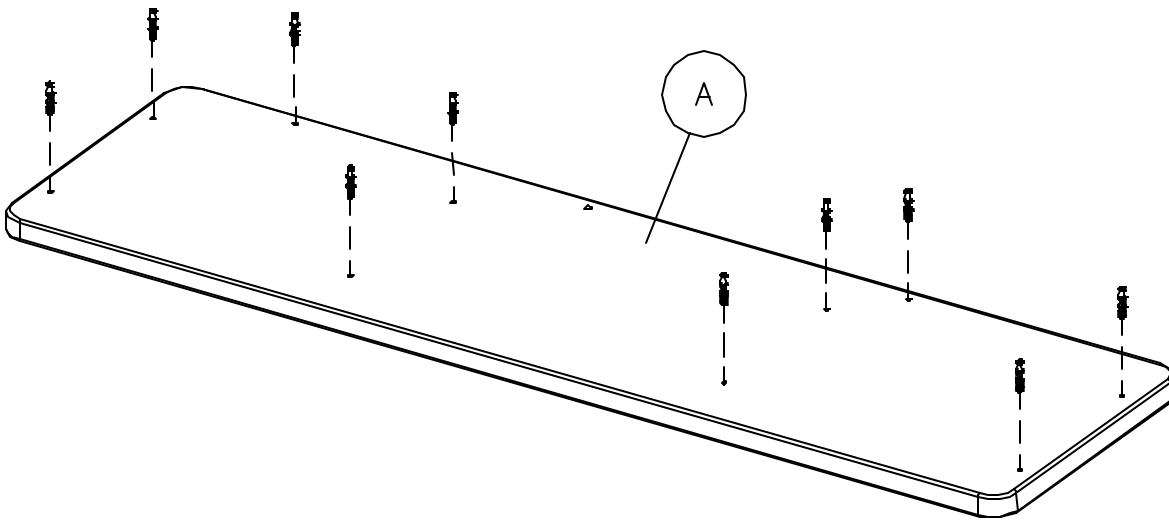

?
1
·
8
0
0
·
9
5
0
·
4
7
8
2

H71659

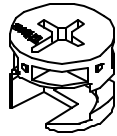

[10]

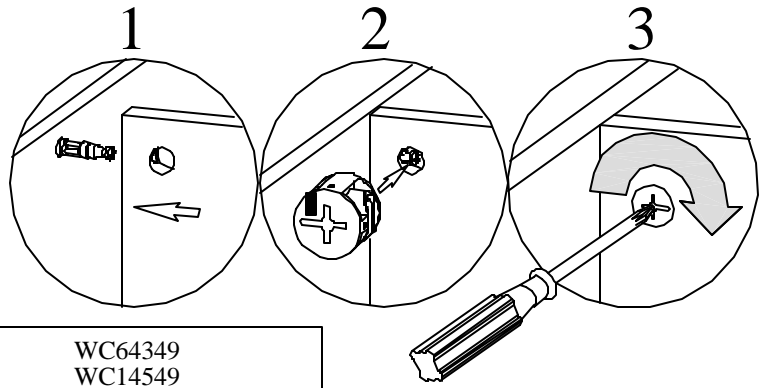

<p>WC14349</p> <p>H92521</p> <p>Quantity 10</p>	<p>WC64349 WC14549</p> <p>H83021</p> <p>Quantity 10</p>	
<p>WC57449 WC84849</p> <p>H97436</p> <p>Quantity 10</p>	<p>WC94449</p> <p>H73621</p> <p>Quantity 10</p>	<p>WC75749</p> <p>H77823</p> <p>Quantity 10</p>

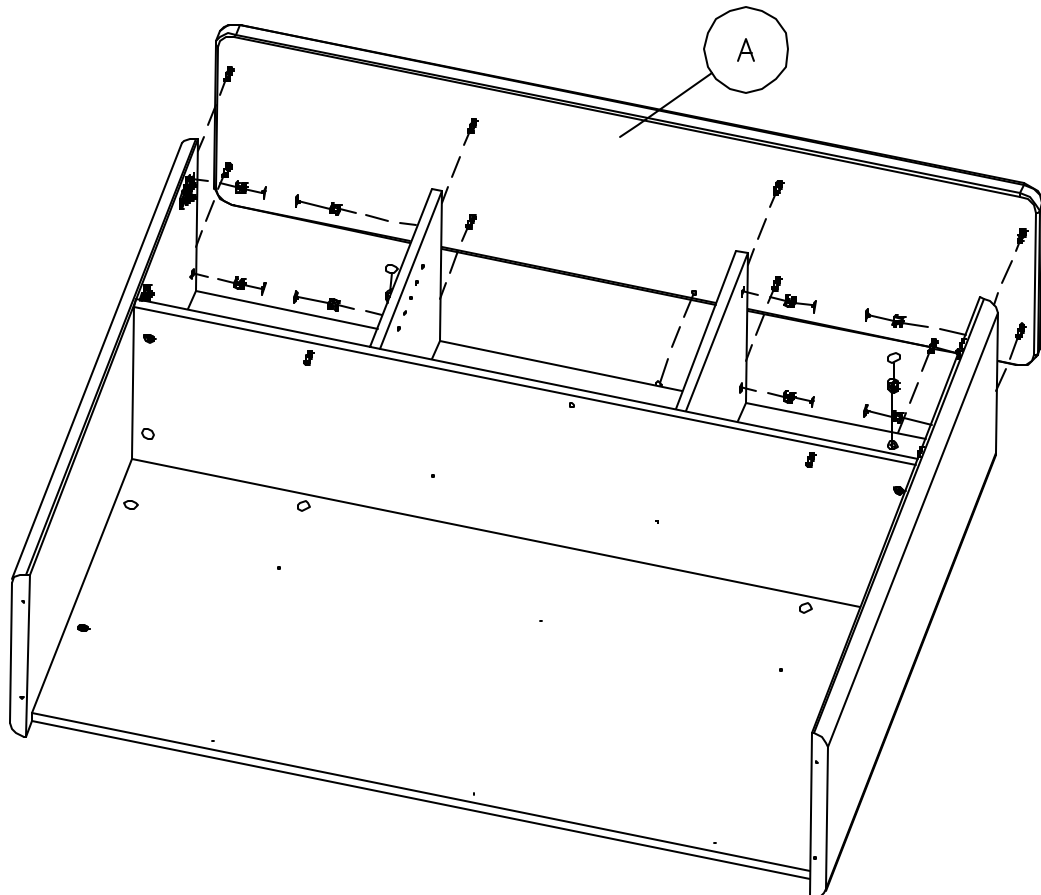

?
1
·
8
0
0
·
9
5
0
·
4
7
8
2



H71659

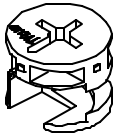

[2]

H38169



[1]

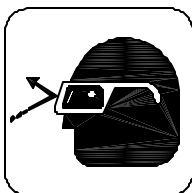
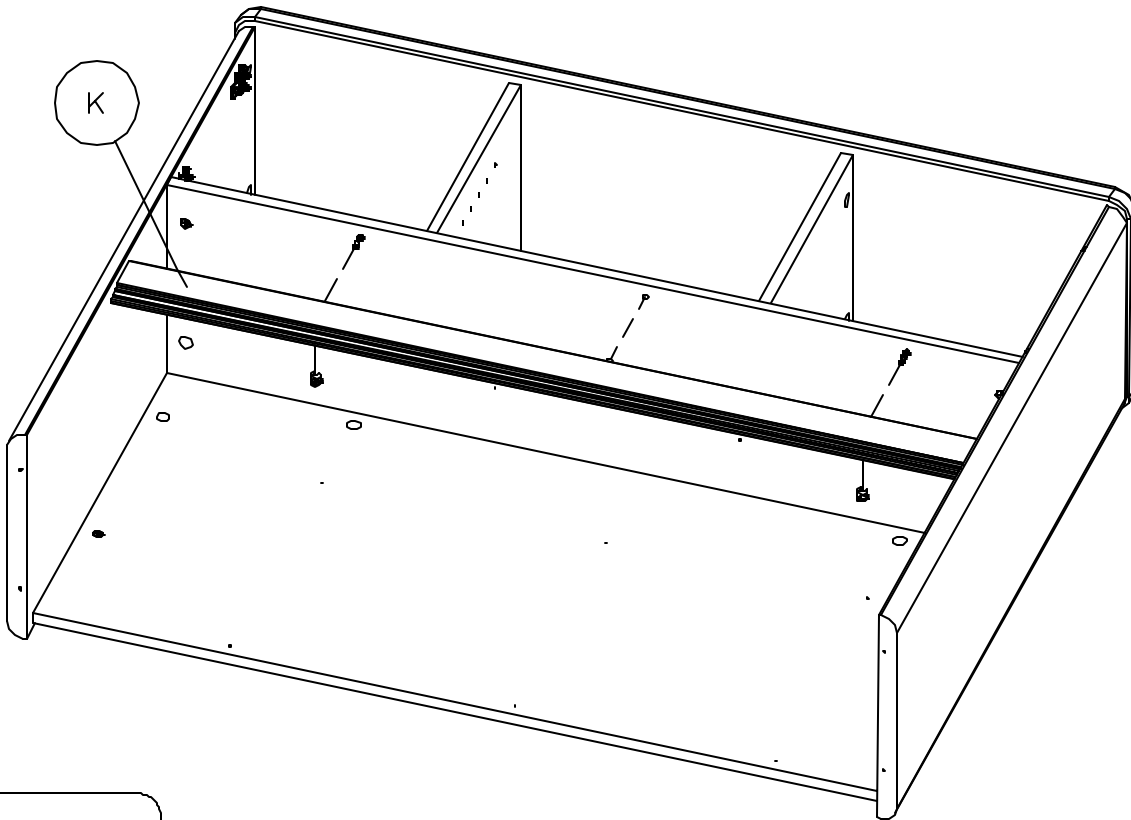
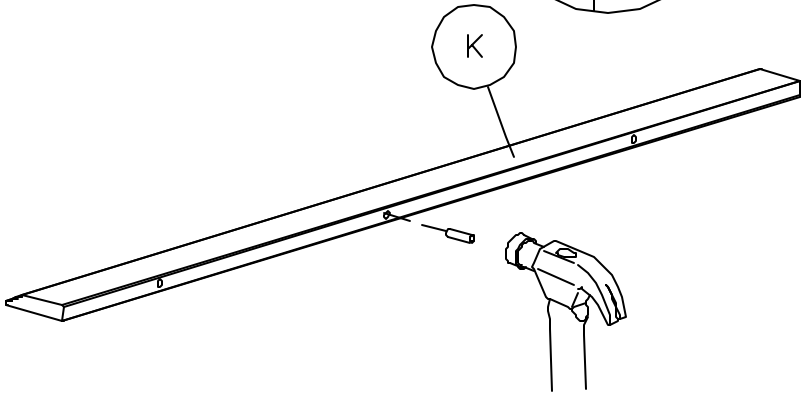
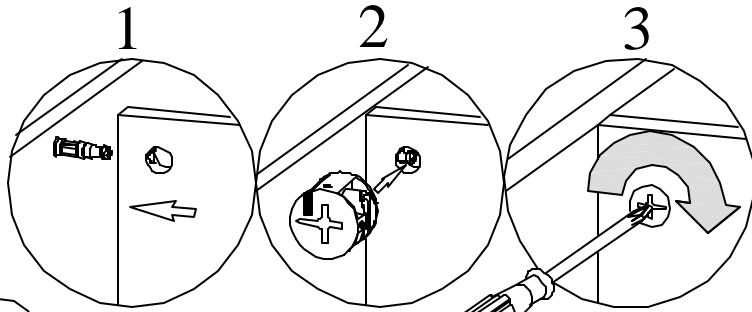

?
1
·
8
0
0
·
9
5
0
·
4
7
8
2

14

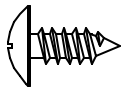
H35251  [6]

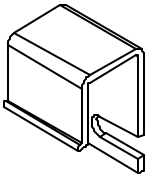
H117284  [3]

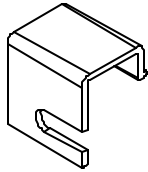
H117285  [3]

?
1
·
8
0
0
·
9
5
0
·
4
7
8
2

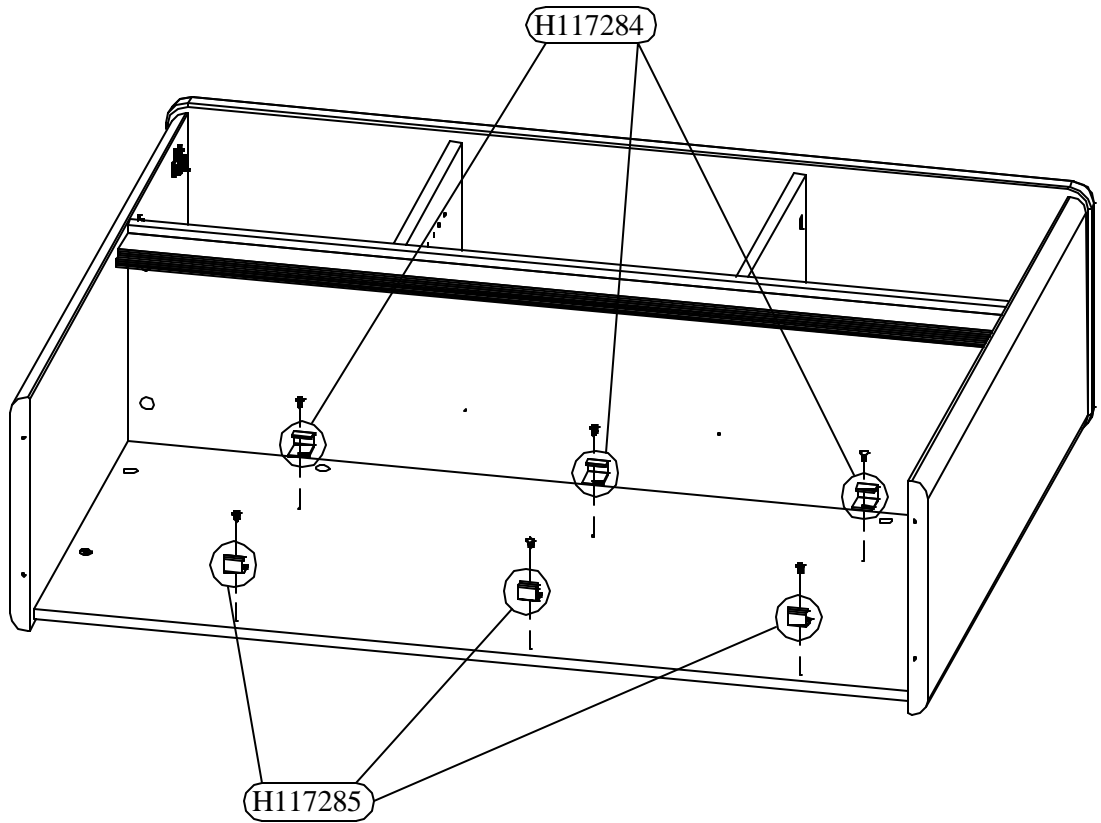

H28917  [8]

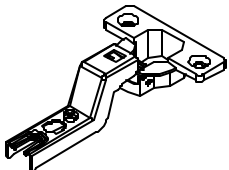
H126757  [4]

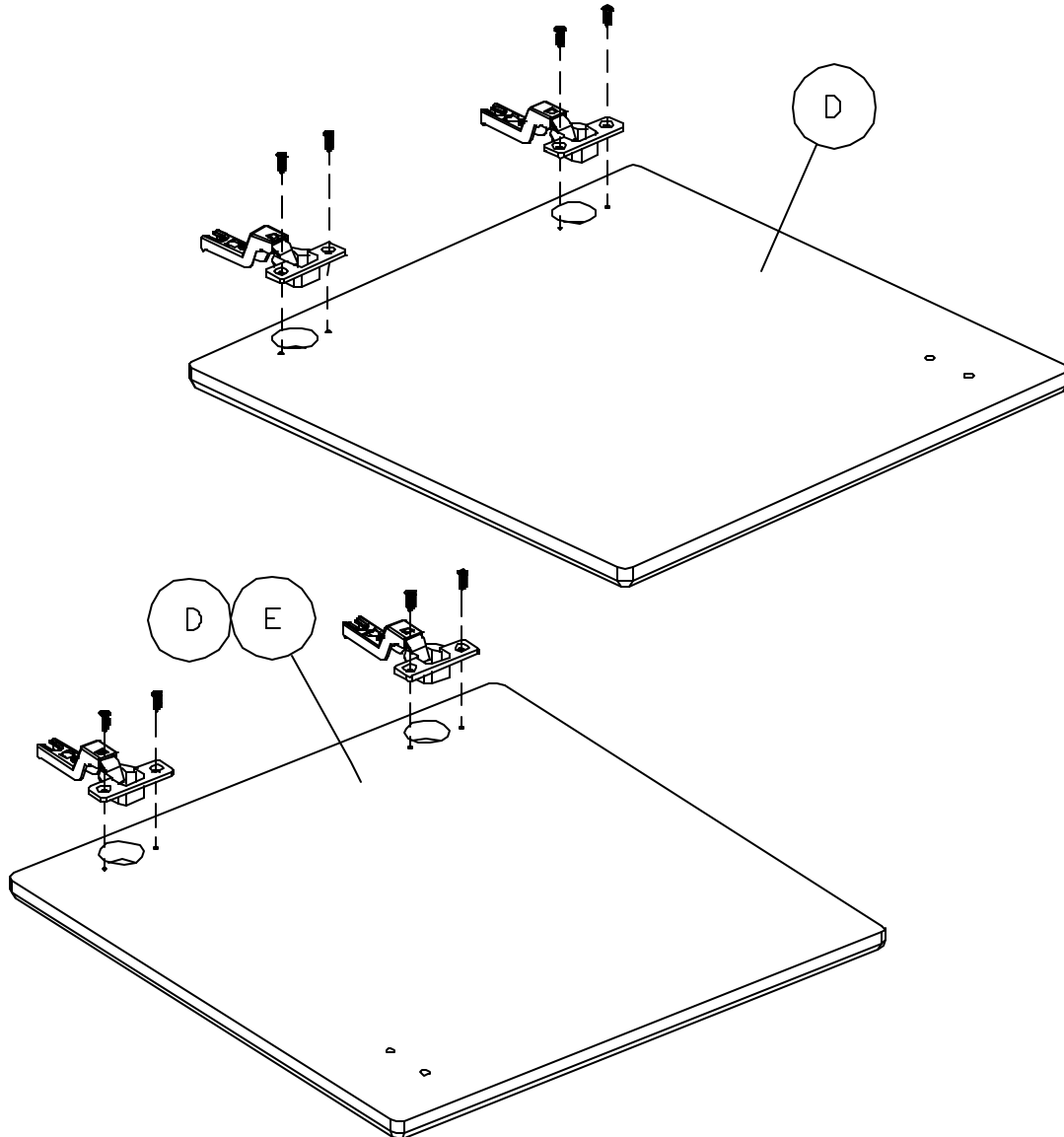

?
1
·
8
0
0
·
9
5
0
·
4
7
8
2

WC14549

H91373 Quantity 2

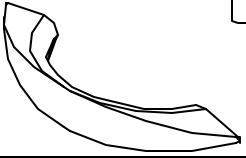

H92138 Quantity 4



8 x 1.125"

WC75749

H83034 Quantity 2

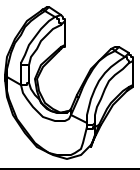

H83431 Quantity 4



8 x 1.25

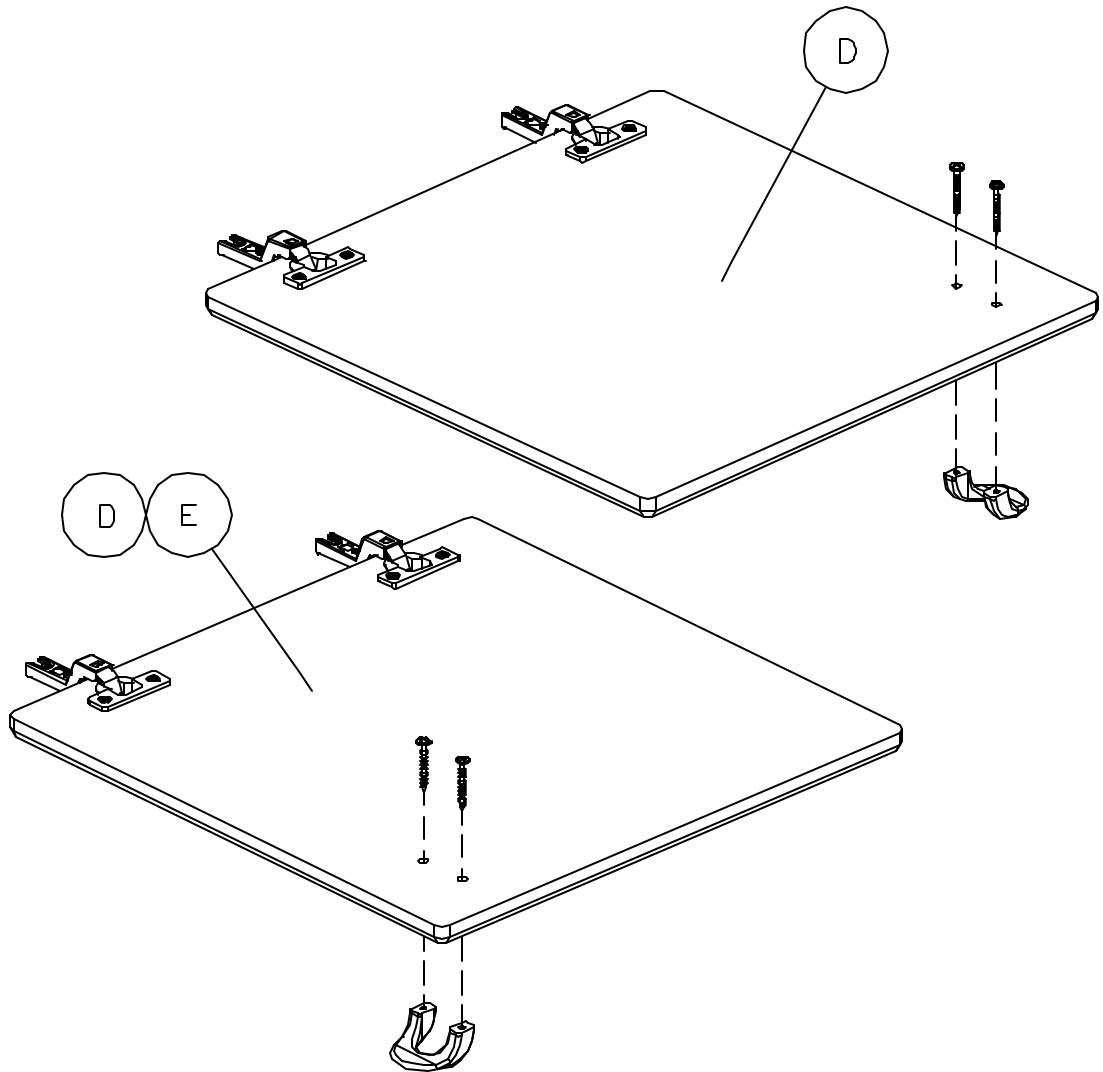

?
1
·
8
0
0
·
9
5
0
·
4
7
8
2



A139403

H29206



[1]

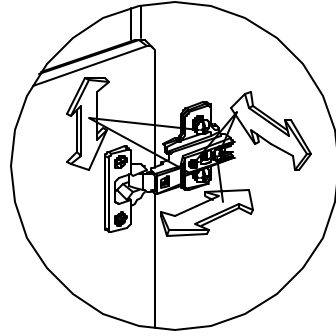

17

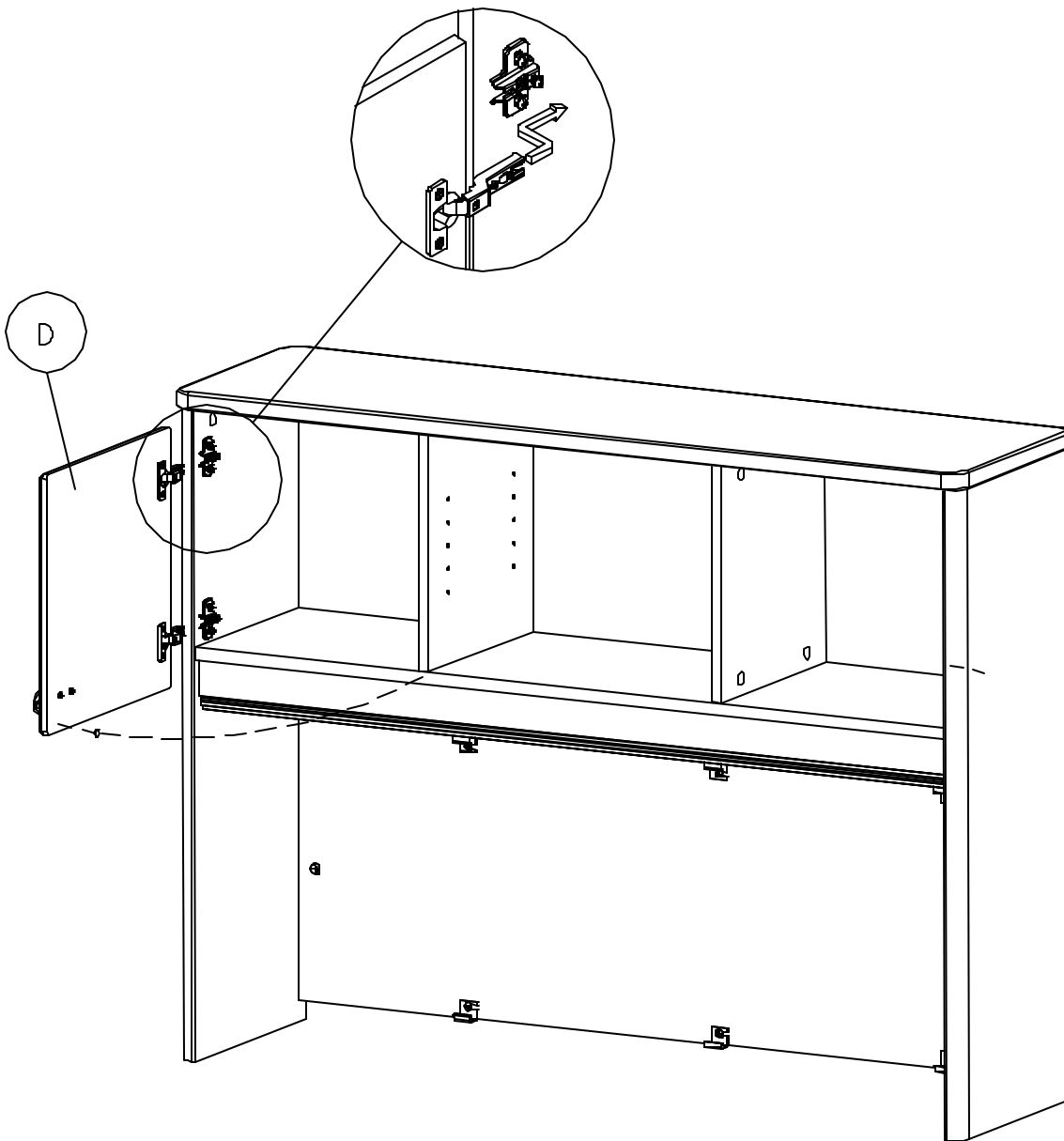

?
1
·
8
0
0
·
9
5
0
·
4
7
8
2

A139403



H29206 [1]

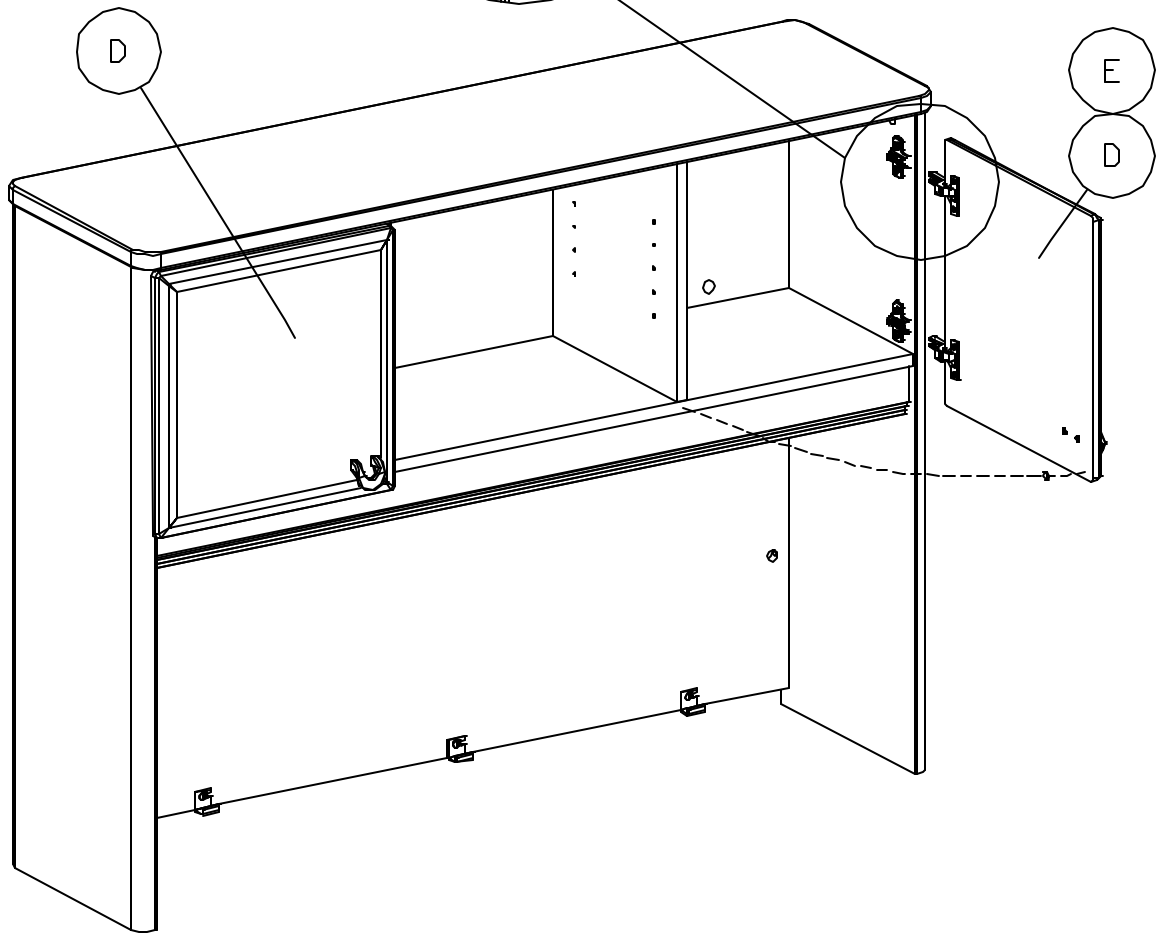
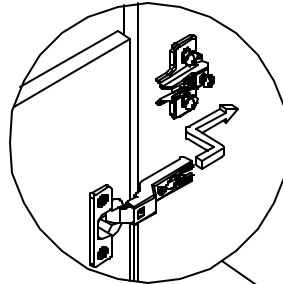
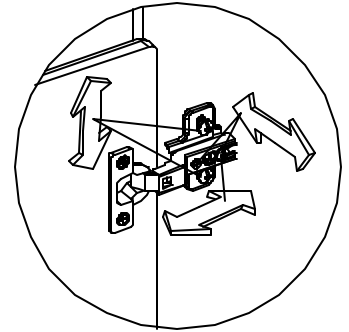

?
1
·
8
0
0
·
9
5
0
·
4
7
8
2



H23491

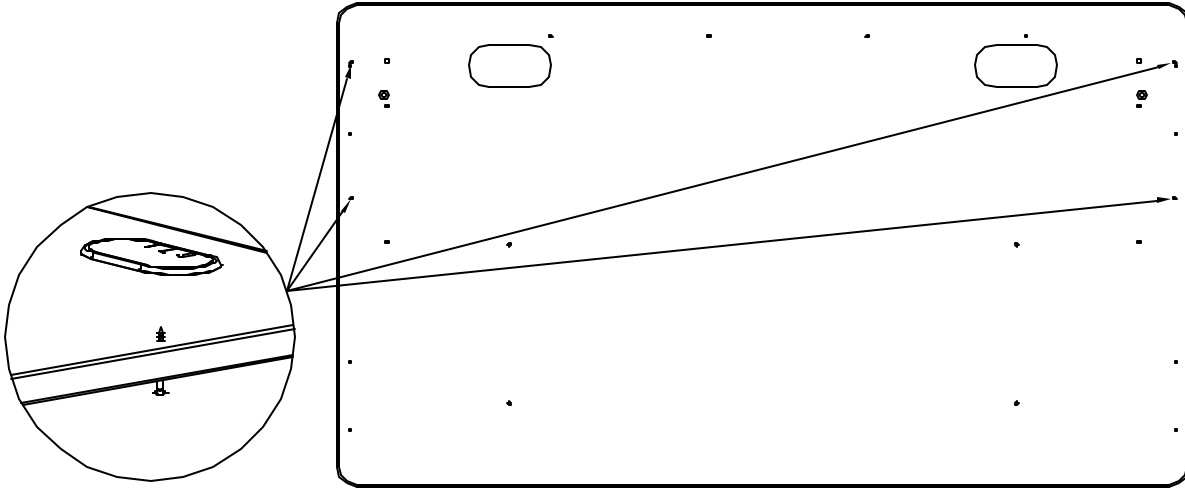

WC14348
WC14548
WC75748
WC57448
WC90448A
WC8448A
WC64348

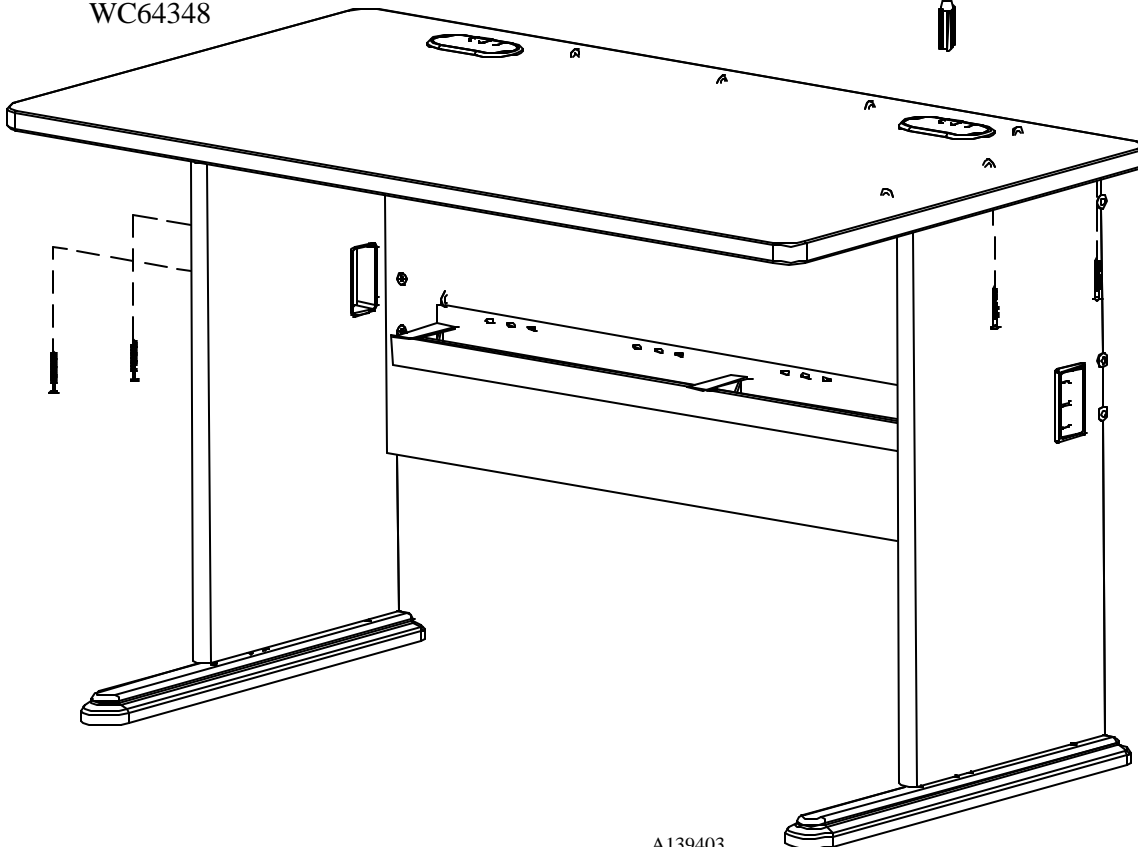
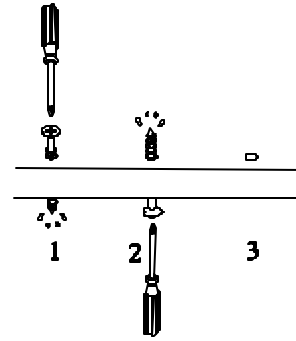

?
1
·
8
0
0
·
9
5
0
·
4
7
8
2

A139403



H23491



An assistant is required.
Es necesario un ayudante.
Un assistant est nécessaire.

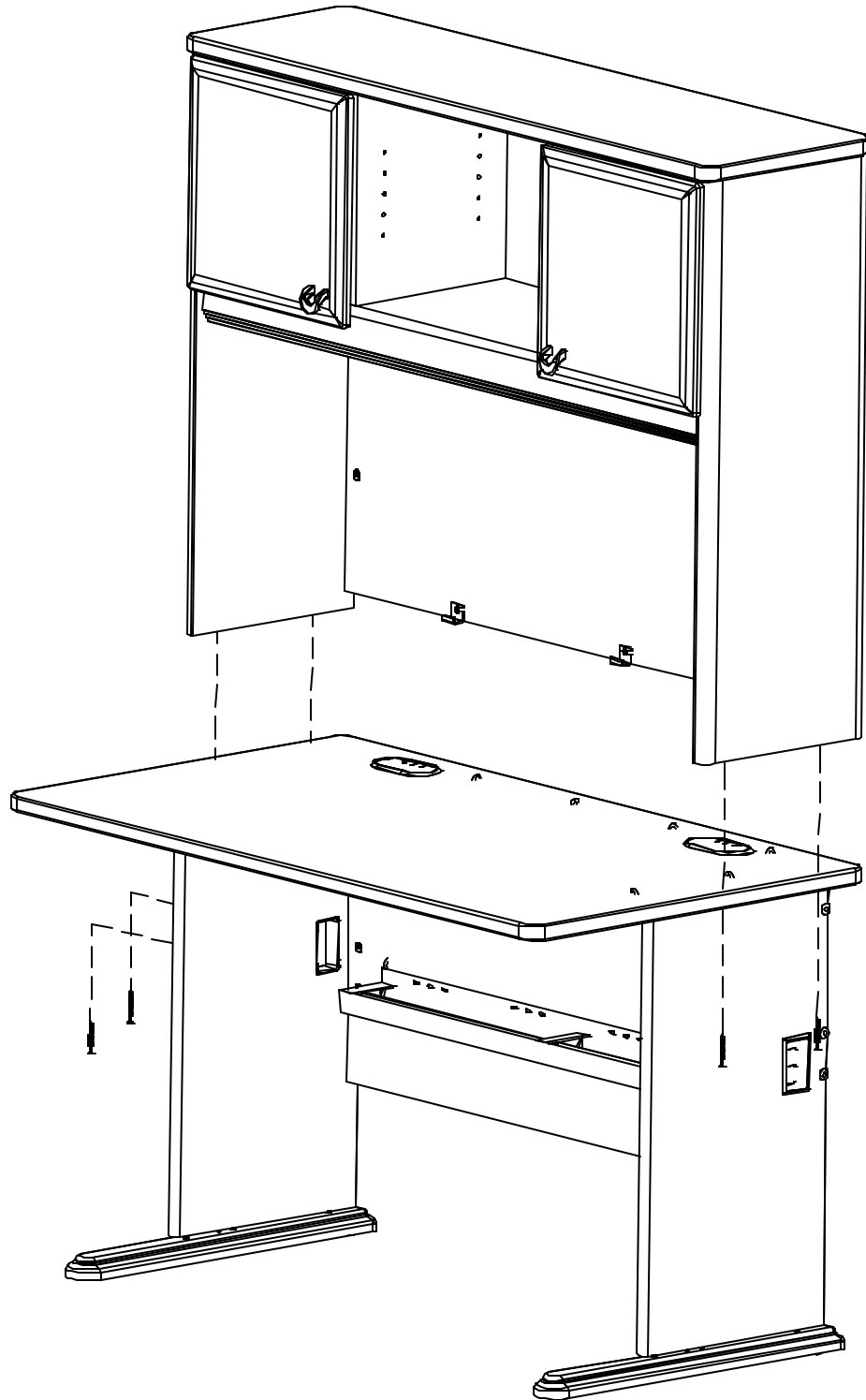

?

1
·
8
0
0
·
9
5
0
·
4
7
8
2



If these holes are not present
go to step 22

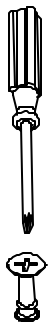
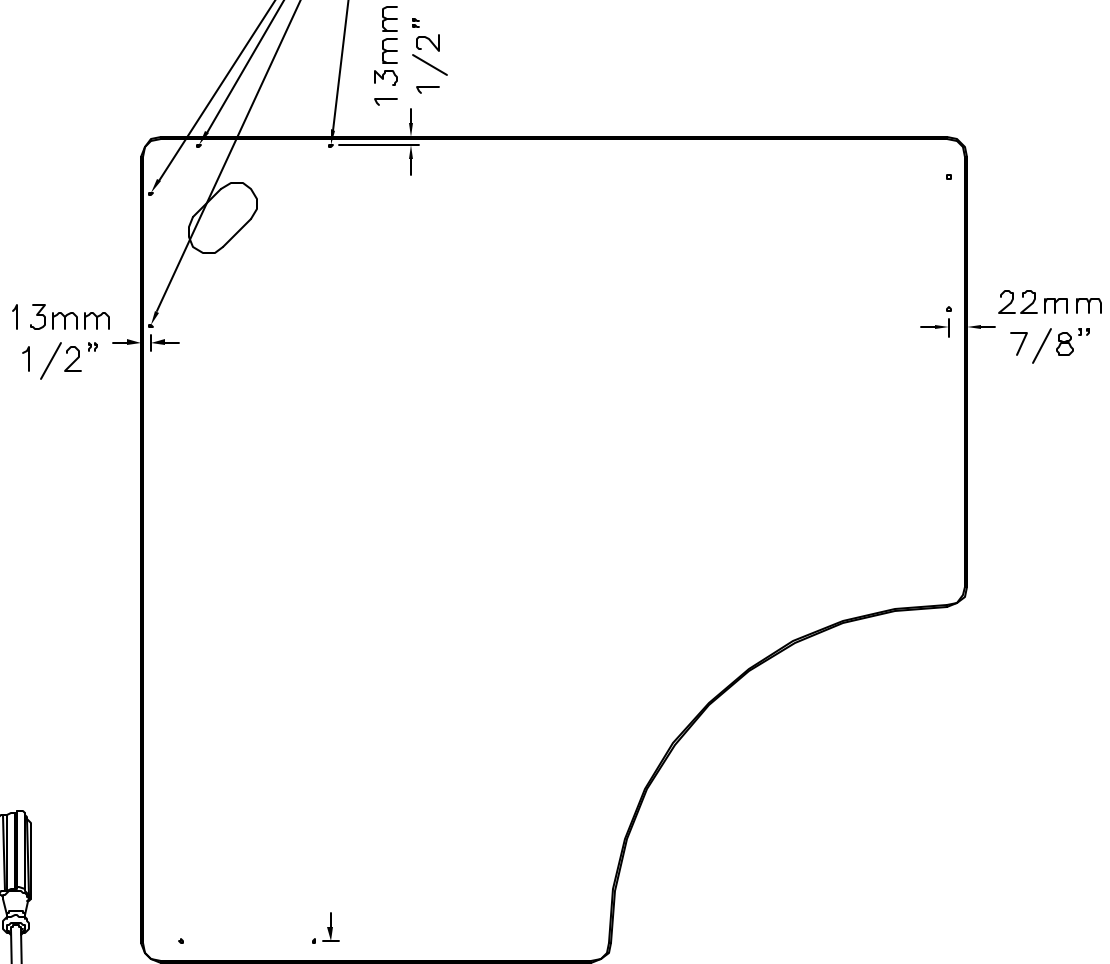

1

2

3



?

1
·
8
0
0
·
9
5
0
·
4
7
8
2

W139404

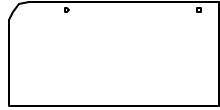

[1]

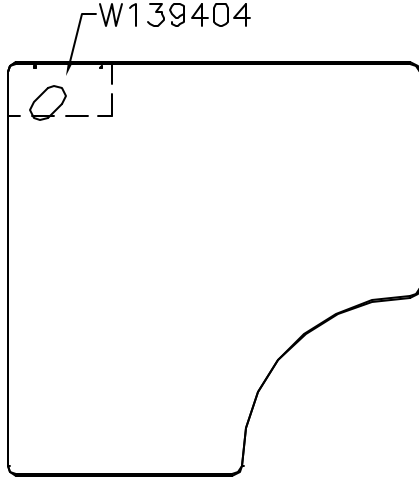

LEFT MOUNTING OPTION

OR

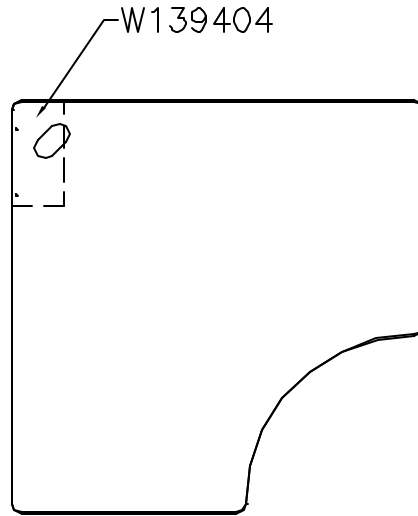

RIGHT MOUNTING OPTION

?
1
·
8
0
0
·
9
5
0
·
4
7
8
2

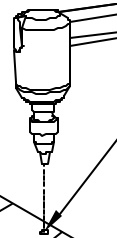

DRILL 6mm or 1/4" HOLE THRU
2 HOLES

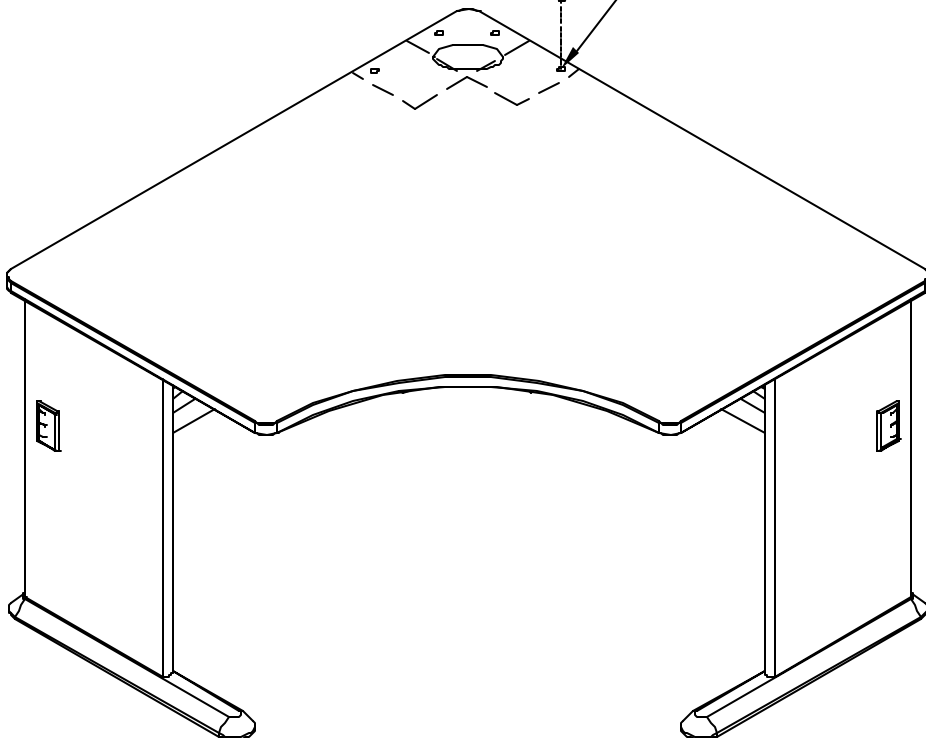

H23491

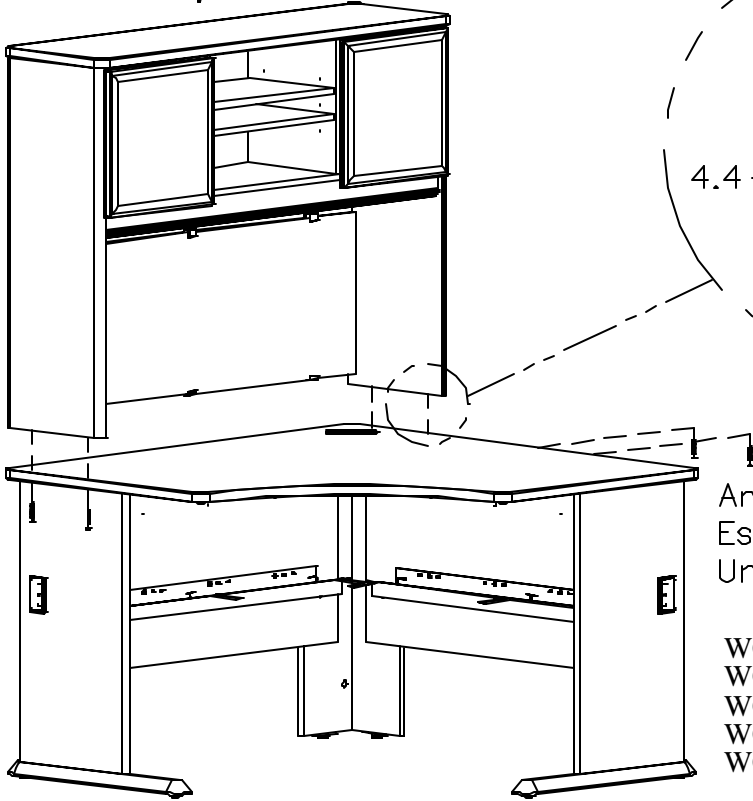
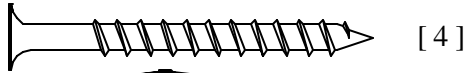

An assistant is required.
Es necesario un ayudante.
Un assistant est nécessaire.

- WC14366
- WC14566
- WC75766
- WC57466
- WC64366

H23491

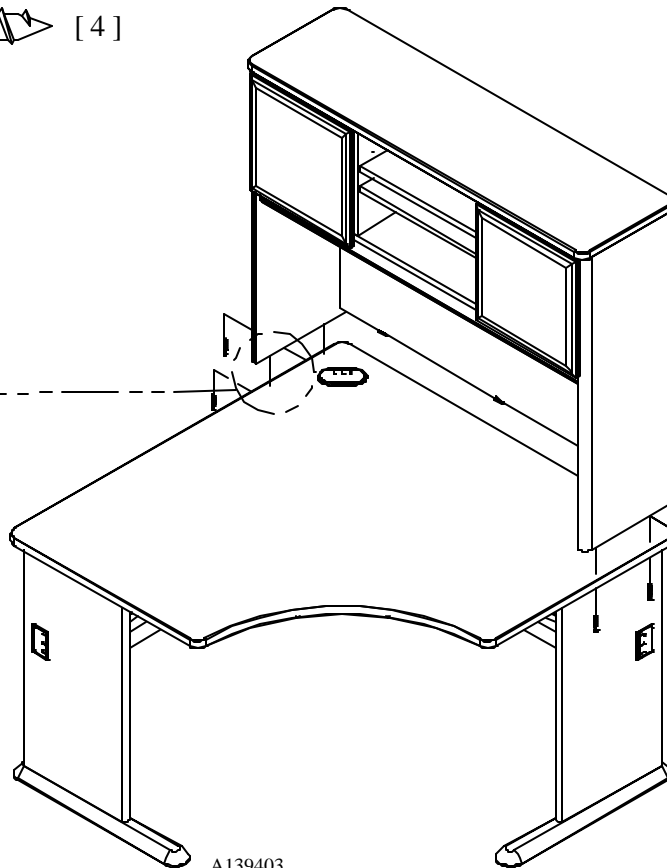
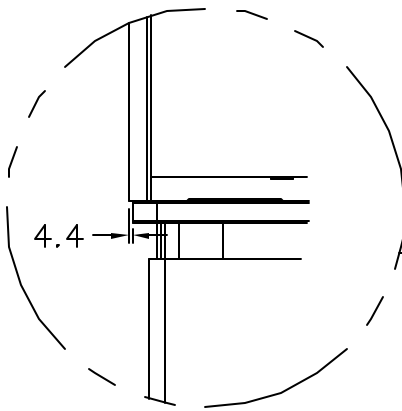
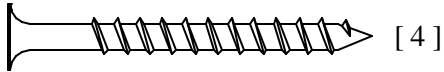

- WC14366
- WC14566
- WC75766
- WC57466
- WC64366

A139403

?
1
·
8
0
0
·
9
5
0
·
4
7
8
2

H23491  [3]

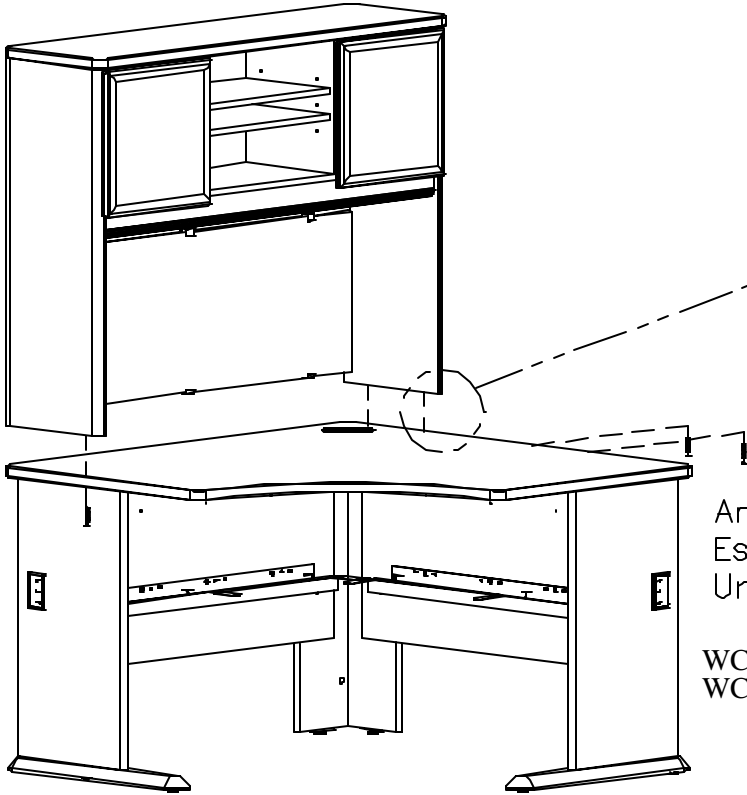

An assistant is required.
Es necesario un ayudante.
Un assistant est nécessaire.

WC90466A
WC8427A

H23491  [3]

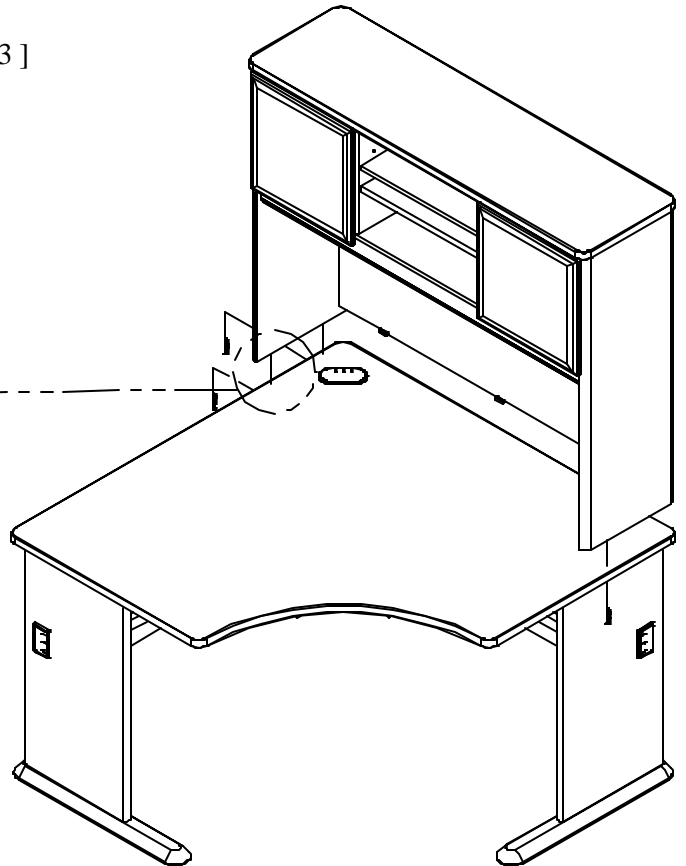
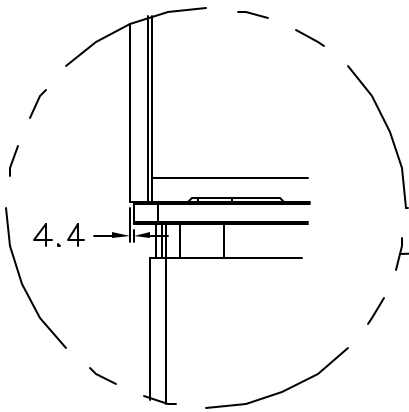

WC90466A
WC8427A

?
1
·
8
0
0
·
9
5
0
·
4
7
8
2



H35251 [4]

H39922 [1]

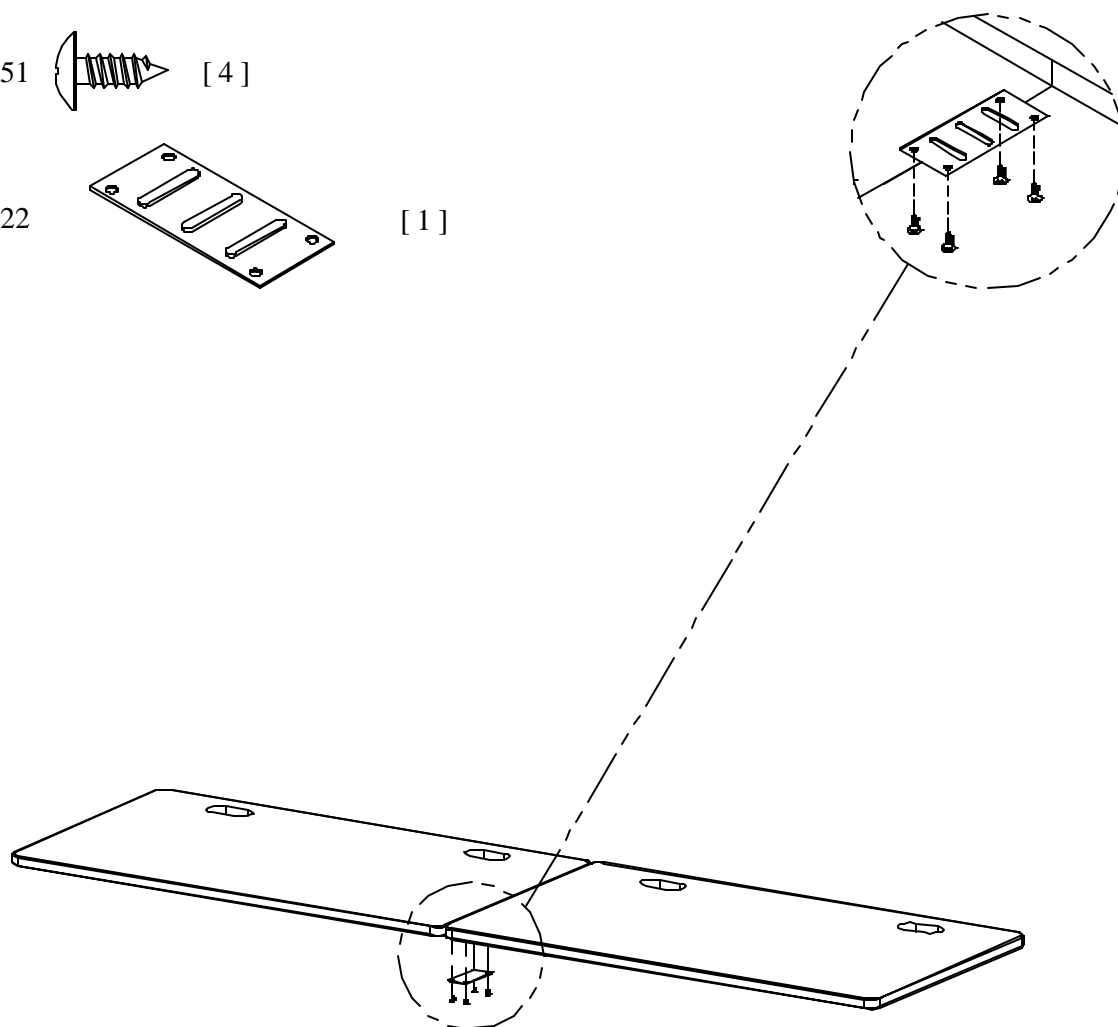

?

1

.

8

0

0

.

9

5

0

.

4

7

8

2

When used with other desk, attach desktops together with strap provided.

Cuanda esta unidad es usada con otro escritorio, los topes de los escritorios de ben sersujetados con la banda de metal suministrada.

Lors de l'utilisation avec un autre bureau, attachez le haut des bureau avec la sangle fournie

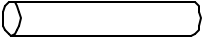
H23604  [8]

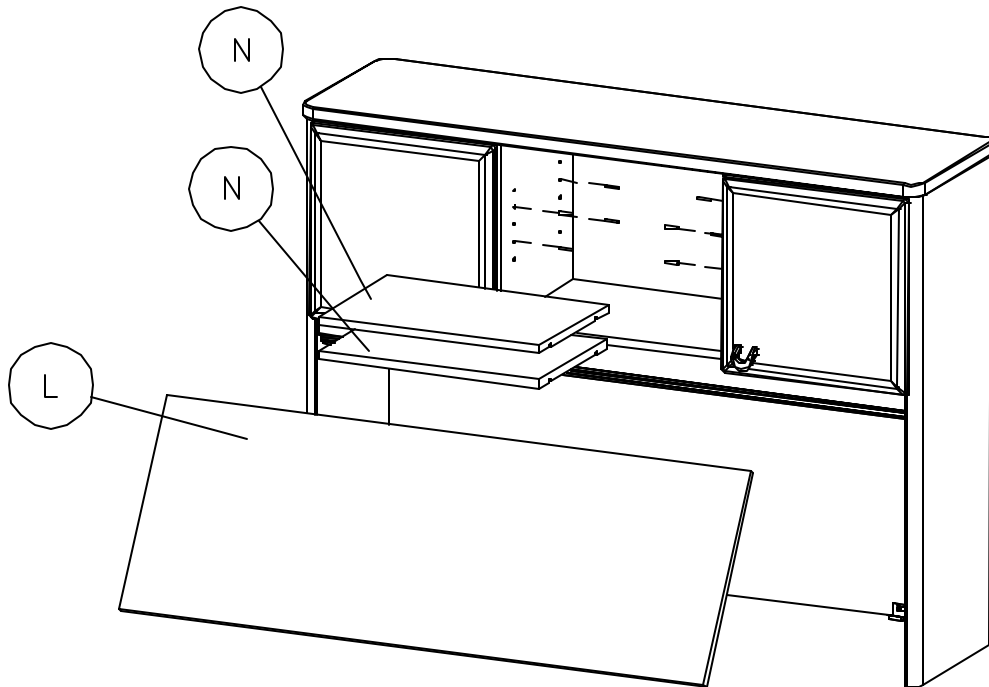
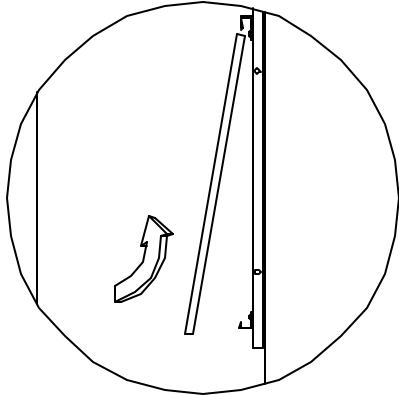

?

1
·
8
0
0
·
9
5
0
·
4
7
8
2

