

MODEL WC14337
WC14537
WC57437
WC64337
WC75737
WC84837
WC94437



Can we help you ?

THE BUSH FURNITURE

difference

- QUALITY
- INNOVATION
- SERVICE
- VALUE

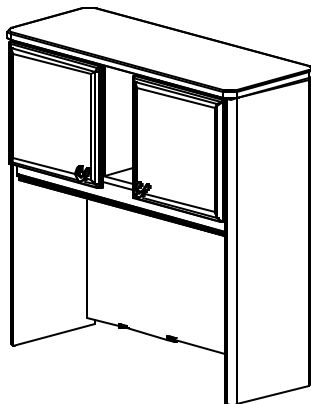

Bush
BUSINESS FURNITURE

Thank you for purchasing this Bush Business Furniture product. We trust that you will be completely satisfied with your product for many years to come. Bush Business Furniture products are backed by a 10 year warranty and crafted with today's styles in mind for the way you live.

Gracias por comprar este producto de Bush Business Furniture. Confiamos que usted estará completamente satisfecho con su mueble por muchos años. Productos de Bush Business Furniture tienen 10 años de garantía y son diseñados con los estilos de hoy en mente para la manera que usted vive.

Merci d'avoir acheté ce produit Furniture Business Bush. Nous comptons sur votre entière satisfaction avec votre produit au long des années à venir. Les produits furniture Business Bush sont garantis pour une période de 10 ans et sont conçus dans les styles d'aujourd'hui gardant à l'esprit votre mode de vie.

Sincerely,

Paul Bush

Paul Bush
President, Bush Industries



10 Year
WARRANTY

Bush™

BUSINESS FURNITURE



M - F 7a.m. - 11p.m.
Sat. 9a.m. - 5:30p.m.
Sun. 9a.m. - 5:30p.m.
(Except Holidays)

1-800-950-4782 USA/CANADA
95-800-950-4782 MEXICO
Se habla Español

Outside USA/ CANADA/ MEXICO:
001-716-665-2510 Ext. 5900

Email us:

ConsumerService@BushIndustries.com



www.bushfurniture.com

10 Year

WARRANTY

IT'S AS EASY AS 1,2,3

Assembly tips:

1. Read the instructions and become familiar with the parts.
2. To protect floors, assemble the furniture on the carton.
3. An assistant may be helpful.
4. Use of power tools is not recommended.

Consejos de Ensamblaje:

1. Lea las instrucciones y familiarícese con las partes.
2. Para proteger el piso, ensamble el mueble en el cartón.
3. Un asistente puede serle útil.
4. El uso de herramientas eléctricas no se recomienda.

Assemblage:

1. Lisez les instructions et familiarisez-vous avec les pièces.
2. Afin de protéger vos sols, assemblez votre meuble sur un carton.
3. Il sera peut-être utile de vous faire aider.
4. L'utilisation d'outils électriques n'est par recommandée.

CONSUMER SERVICE YOU CAN DEPEND ON

Questions? Operators are standing by at our TOLL FREE help line to assist you with assembly, and if necessary, quickly replace damaged/missing parts. Assistance is available all day every day. Simply have your store receipt, instruction manual, and part number/description ready when you call our TOLL FREE help line. It's that easy.

Servicio al consumidor en que usted puede depender

¿ Preguntas ? Operadores estan listos en nuestra LINEA DE ASISTENCIA GRATUITA para ayudarle con ensamblaje y si sea necesario reemplazo rápido de partes dañadas o que falten. Asistencia está disponible todo el día todos los días. Simplemente tenga listo su recibo de la tienda, la hoja de instrucciones, y número de parte/descripción cuando llame nuestra LINEA DE ASISTENCIA GRATUITA. Es así de fácil.

Vous pouvez compter sur notre service clientèle

des Questions? Nos opérateurs se tiennent à votre disposition, veuillez contacter notre NUMERO GRATUIT D'ASSISTANCE CLIENTS, où l'on vous portera assistance dans votre assemblage, et si nécessaire, pour le remplacement des pièces défectueuses ou manquantes. Cette assistance est disponible 24/24 et 7/7 jours. Quand vous appelez le NUMERO GRATUIT D'ASSISTANCE CLIENTS, veuillez simplement avoir à portée de main votre ticket d'achat, le manuel d'instructions et les références du modèle. C'est aussi simple que cela.



WARNING

This product is designed and intended for use with computer, fax, and printer equipment only. Improper loading with television or other heavy equipment could cause instability, tip over, and/or serious injury.

Este producto esta diseñado solamente para el uso con computadores, faxes, e impresoras. Inapropiado uso al poner televisores u otro equipo pesado puede causar inestabilidad, rodamiento, y/o herida (golpes) serios.

Ce produit est uniquement conçu pour une utilisation avec un ordinateur, un télécopieur, ou une imprimante. Un chargement incorrect avec une télévision ou autre matériel lourd peut le rendre instable ou le renverser, et peut vous causer des endommagements sérieux.



WARNING

This hutch is intended to be attached to base units that are interconnected in L-or U-shaped workstations. If the hutch is not attached to interconnected base units in this manner, then the combined units must be placed against a wall. Improper assembly or usage could cause instability, tip over, and/or serious injury. Any questions, please call 1-888-592-0083.

Este gabinete ha sido diseñado para ser conectado a otras unidades de trabajo en forma de "L" o "U".S; este gabinete no esta sujetado a unidades de bases interconectadas, las unidades combinadas siempre deben ser colocadas contra una pared. Si tiene preguntas con relación a este procedimiento, favor de llamar 1-888-592-0083

Ce vaisselier est supposé être attaché aux unités interconnectés, alors les unités assemblés doivent être mises contre un mur. Pour toutes questions, veuillez appeler le 1-888-592-0083.



WARNING

Do not move unit when loaded. Doing so could cause instability, product collapse, tip over, and/or serious injury.

No mueva la unidad cuando esté cargada. Hacerlo puede causar inestabilidad, que el producto se derrumbe, que se la caiga encima y/o heridas (golpes) serias.

Ne pas déplacer l'unité lorsqu'ell est chargée. Faire ainsi peut causer l'instabilité, l'effondrement ou le renversement du meuble et/ou des endommagements sérieux.

IMPORTANT SAFETY INFORMATION

EXPLODED VIEW

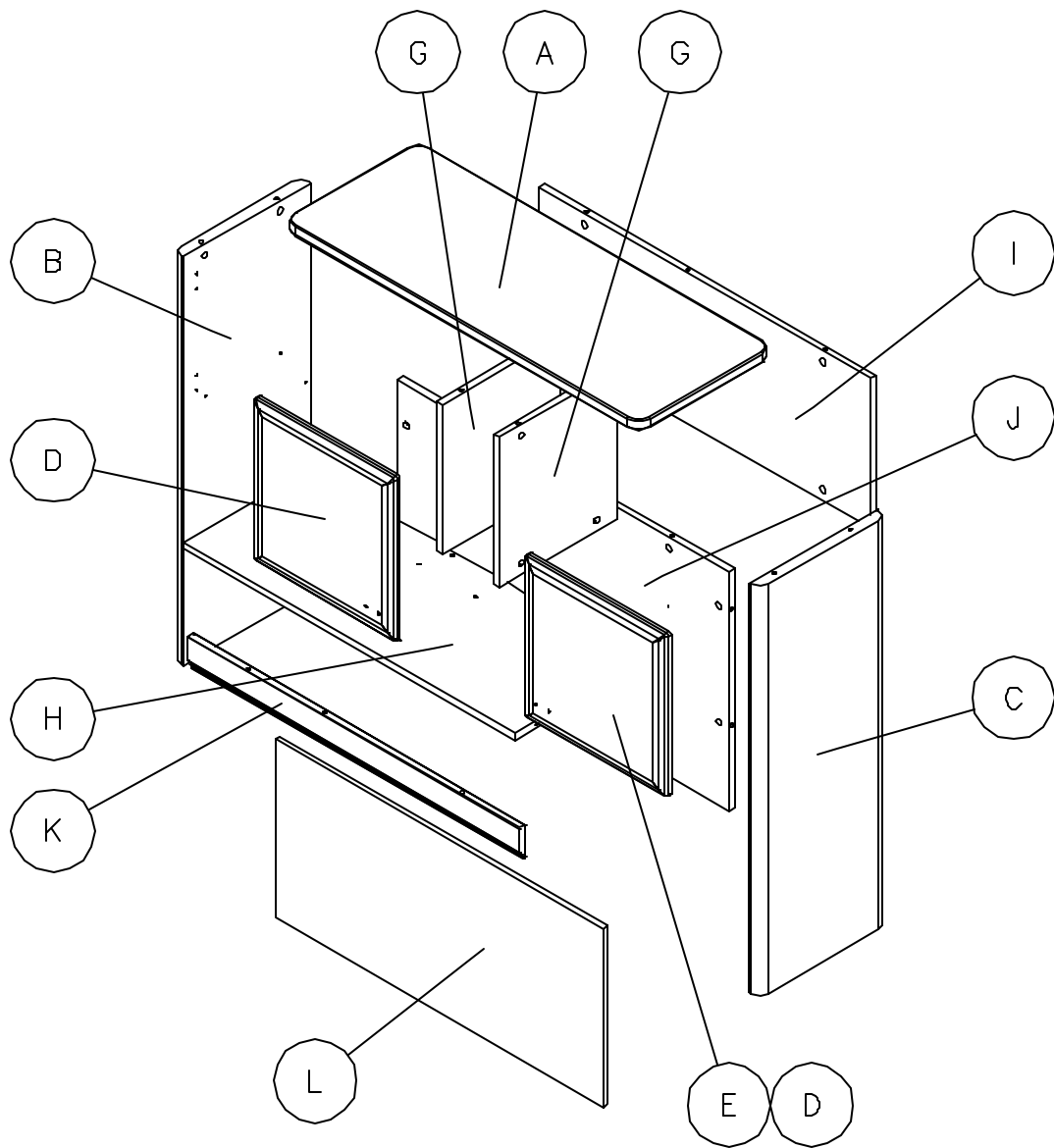
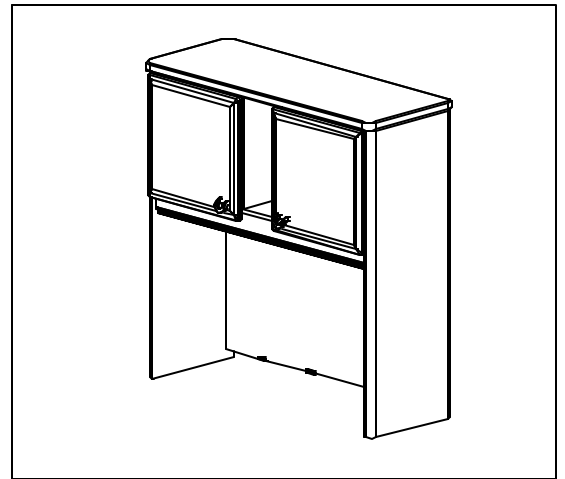

1
8
0
0
9
5
0
4
7
8
2



WC14337

A	[1]	W133494
B	[1]	W88496
C	[1]	W88497
D	[2]	W88498
G	[2]	W88503
H	[1]	W133495
I	[1]	W133496
J	[1]	W133497
K	[1]	W133746
L	[1]	S125755

WC14537

A	[1]	W133516
B	[1]	W82307
C	[1]	W82308
D	[1]	W82314
E	[1]	W82334
G	[2]	W82313
H	[1]	W133517
I	[1]	W133518
J	[1]	W133519
K	[1]	W133741
L	[1]	S125748

WC57437

A	[1]	W133521
B	[1]	W88496
C	[1]	W88497
D	[2]	W93348
G	[2]	W88503
H	[1]	W133495
I	[1]	W133496
J	[1]	W133497
K	[1]	W133745
L	[1]	S125755

WC64337

A	[1]	W133523
B	[1]	W130071
C	[1]	W130072
D	[2]	W130078
G	[2]	W130074
H	[1]	W133524
I	[1]	W133525
J	[1]	W133526
K	[1]	W133742
L	[1]	S130079

WC75737

A	[1]	W133505
B	[1]	W83178
C	[1]	W83179
D	[1]	W83185
E	[1]	W83186
G	[2]	W83184
H	[1]	W133506
I	[1]	W133507
J	[1]	W133508
K	[1]	W133747
L	[1]	S125753

WC84837

A	[1]	W133535
B	[1]	W88496
C	[1]	W88497
D	[2]	W104566
G	[2]	W88503
H	[1]	W133495
I	[1]	W133496
J	[1]	W133497
K	[1]	W133744
L	[1]	S125748

WC94437

A	[1]	W133529
B	[1]	W98955
C	[1]	W98956
D	[2]	W98957
G	[2]	W99096
H	[1]	W133530
I	[1]	W133531
J	[1]	W133532
K	[1]	W133743
L	[1]	S125751



FASTENER LIST

H72988 Quantity
28

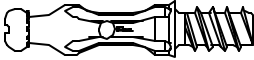

H71659 Quantity
28

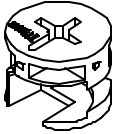

H38169 Quantity
4

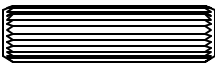

8 x 30 mm

H35251 Quantity
10

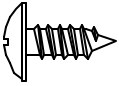

10 x .5"

H28917 Quantity
8



#6 x 1/2"

H23491 Quantity
4



#10 x 2"

1
·
8
0
0
·
9
5
0
·
4
7
8
2



HARDWARE LIST

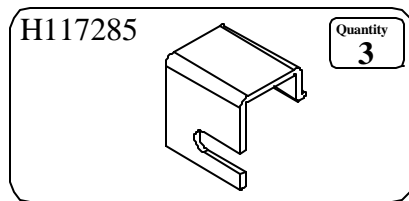
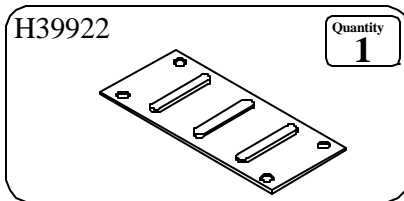
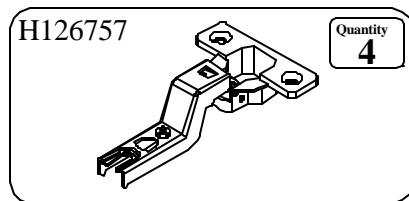
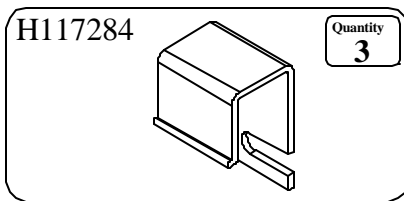
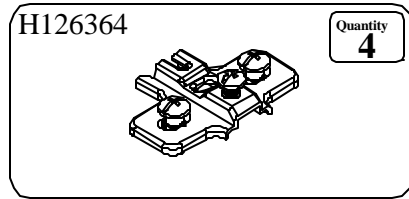
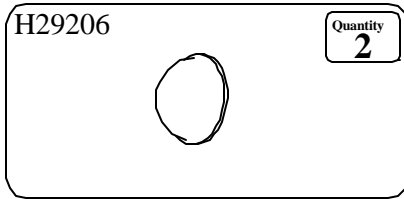

?
1
·
8
0
0
·
9
5
0
·
4
7
8
2

MODEL SPECIFIC HARDWARE

1
8
0
0
9
5
0
4
7
8
2

WC75737

H83431 Quantity 4



8 x 1.25

H83034 Quantity 2

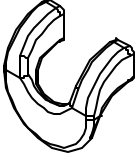

H77823 Quantity 22

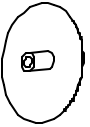

WC14537

H92138 Quantity 4



8 x 1.125"

H91373 Quantity 2

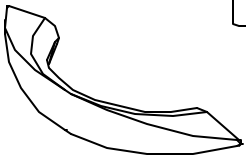

H83021 Quantity 22



WC14337

H92521 Quantity 22

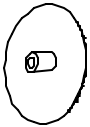

WC64337

H83021 Quantity 22

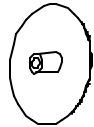

WC57437 WC84837

H97436 Quantity 22

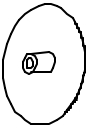

WC94437

H73621 Quantity 22





H38169

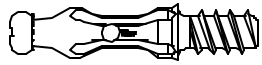

[2]

H72988



[10]

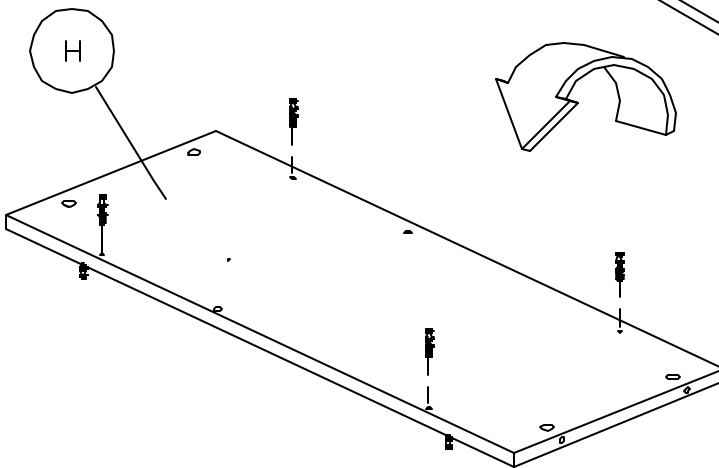
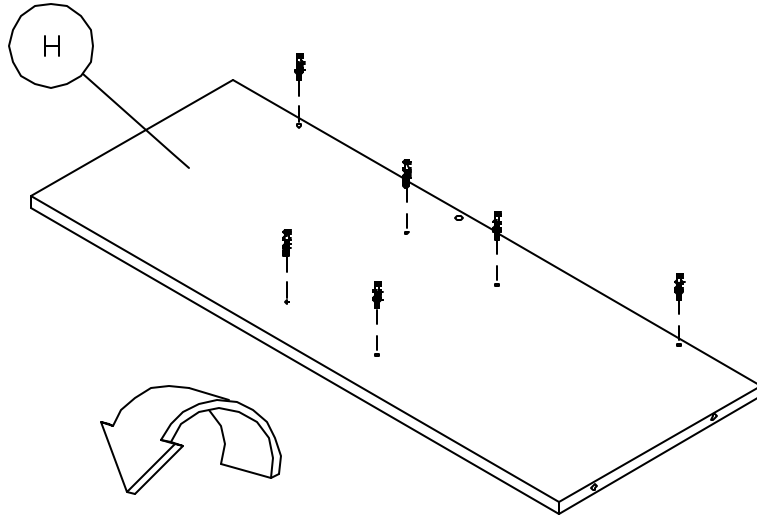
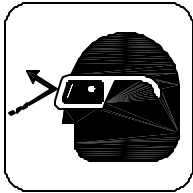
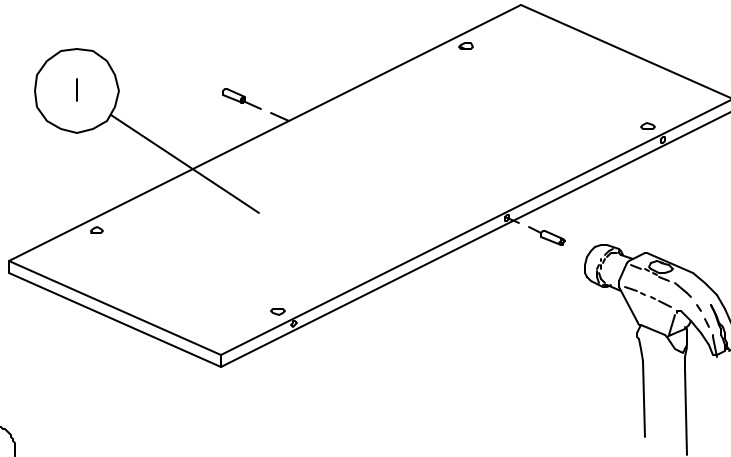
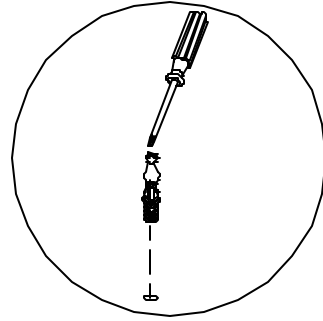

1

?
1
·
8
0
0
·
9
5
0
·
4
7
8
2

2

H71659

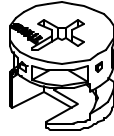

[2]

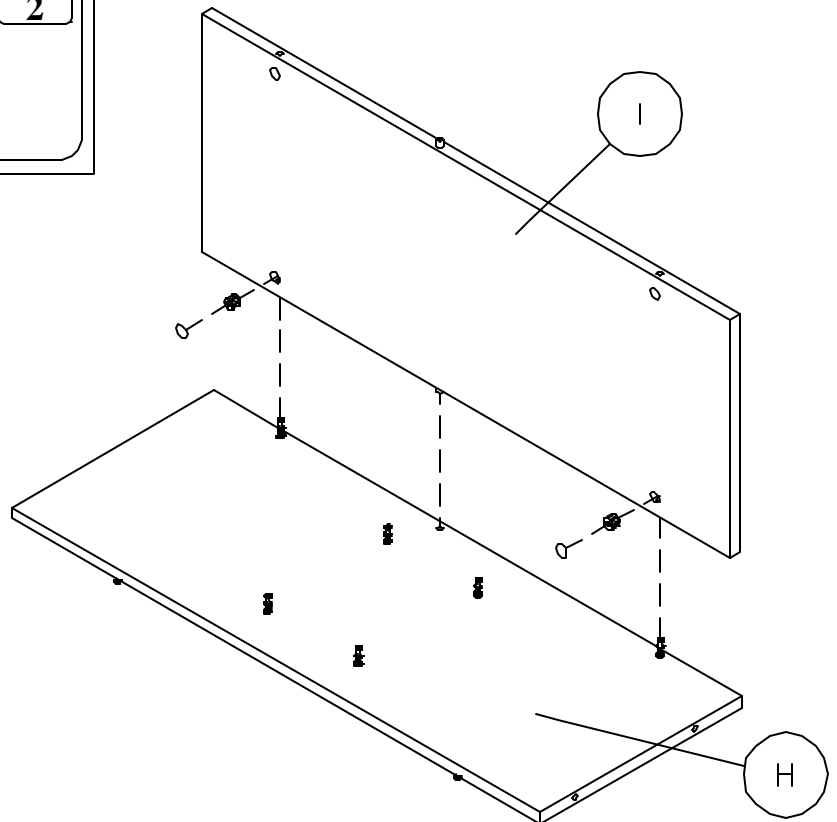
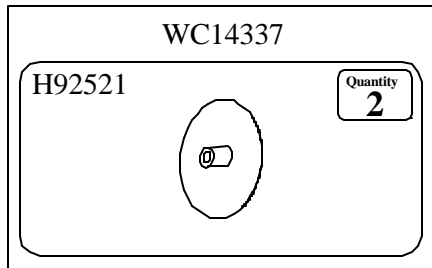
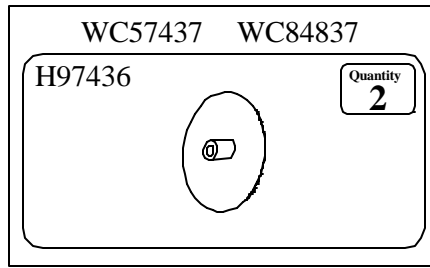
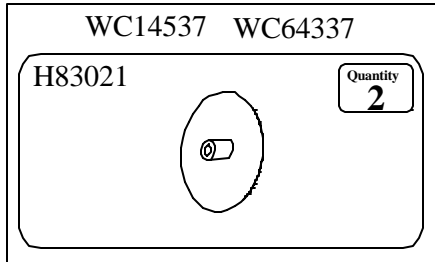
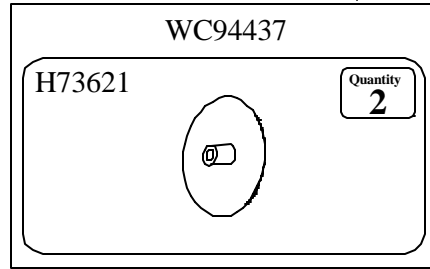
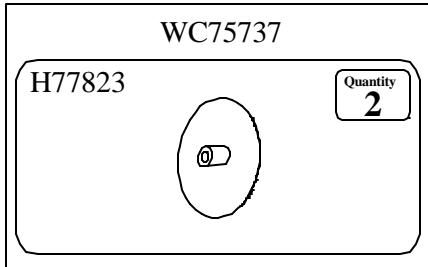
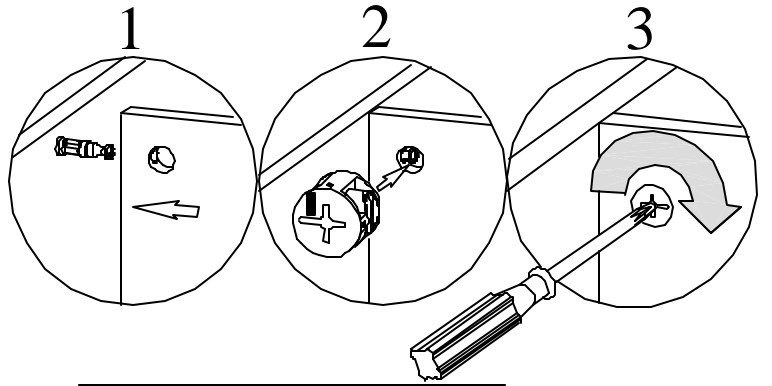

?

1
·
8
0
0
·
9
5
0
·
4
7
8
2



H71659

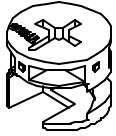

[4]

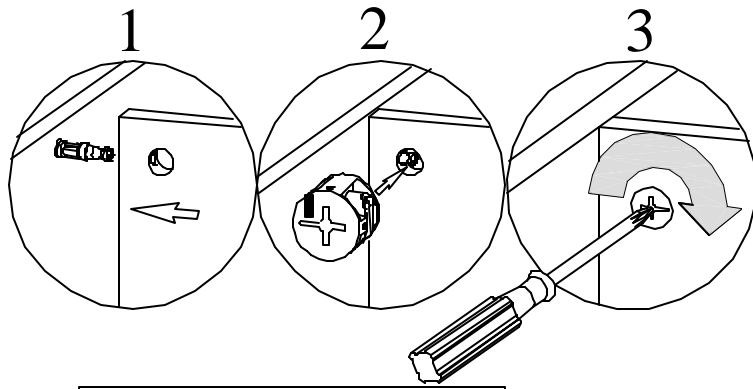

3

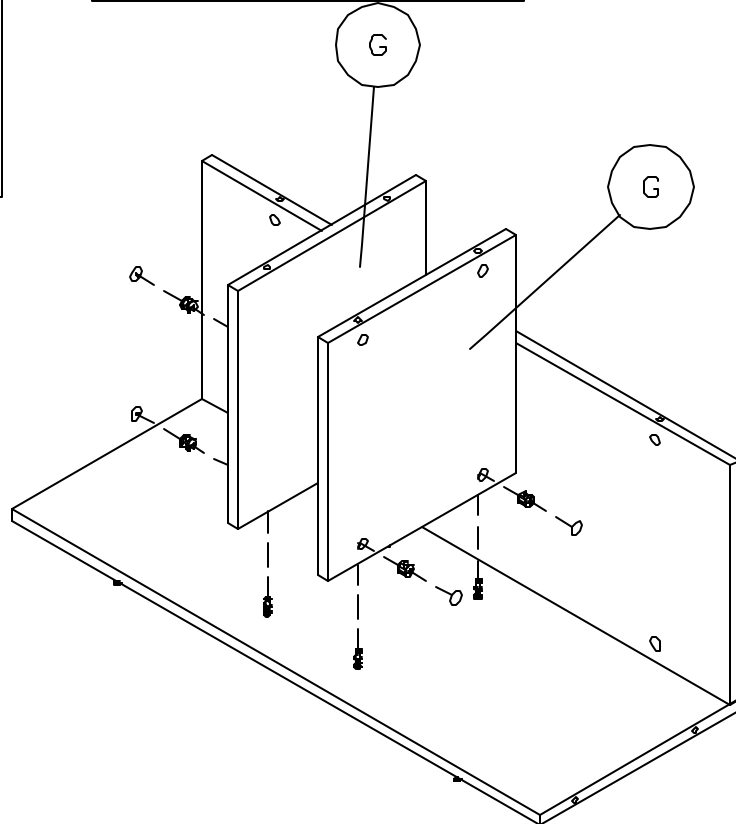
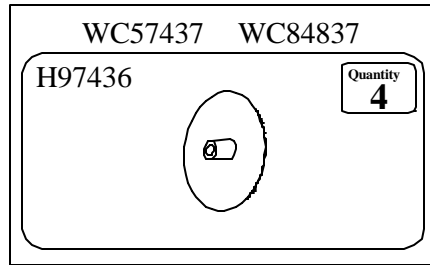
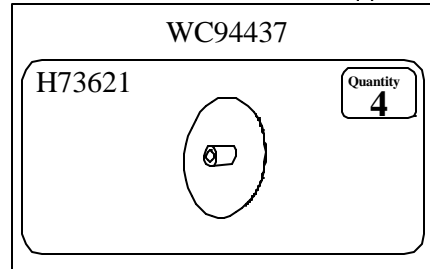
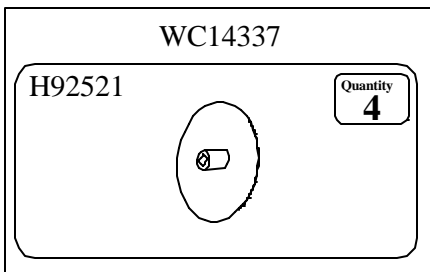
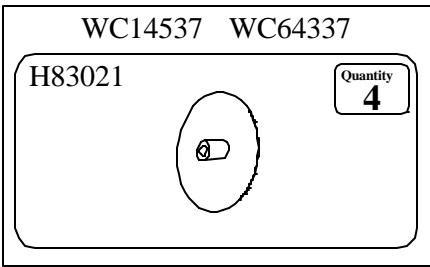
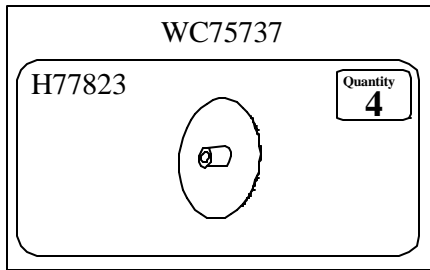

?
1
·
8
0
0
·
9
5
0
·
4
7
8
2

A133504



4

H38169

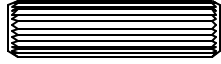

[1]

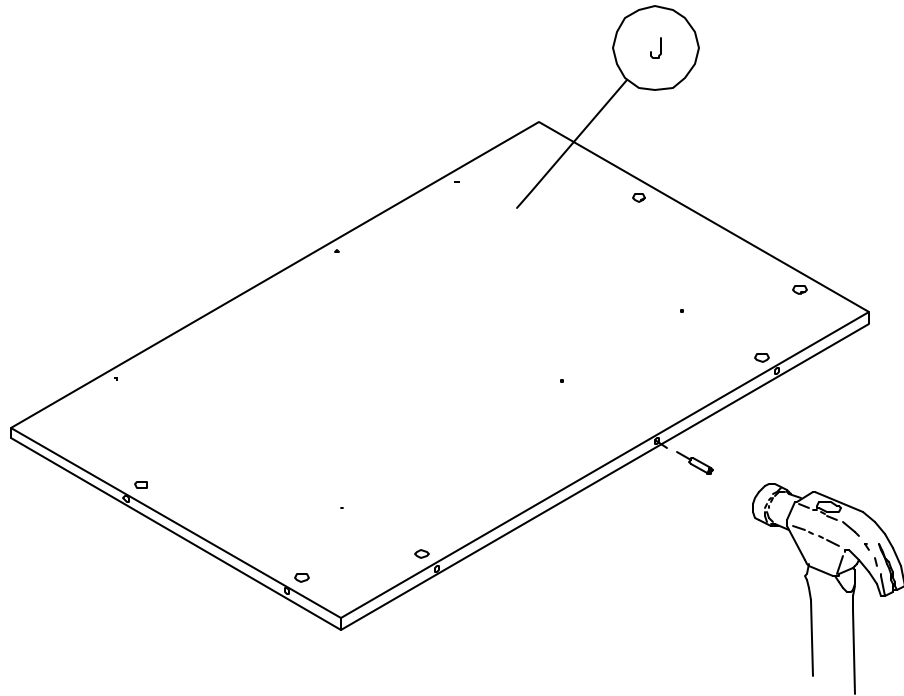

?

1
·
8
0
0
·
9
5
0
·
4
7
8
2

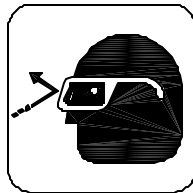

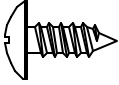
H35251  [3]

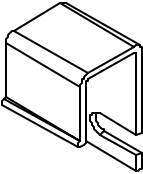
H117284  [3]

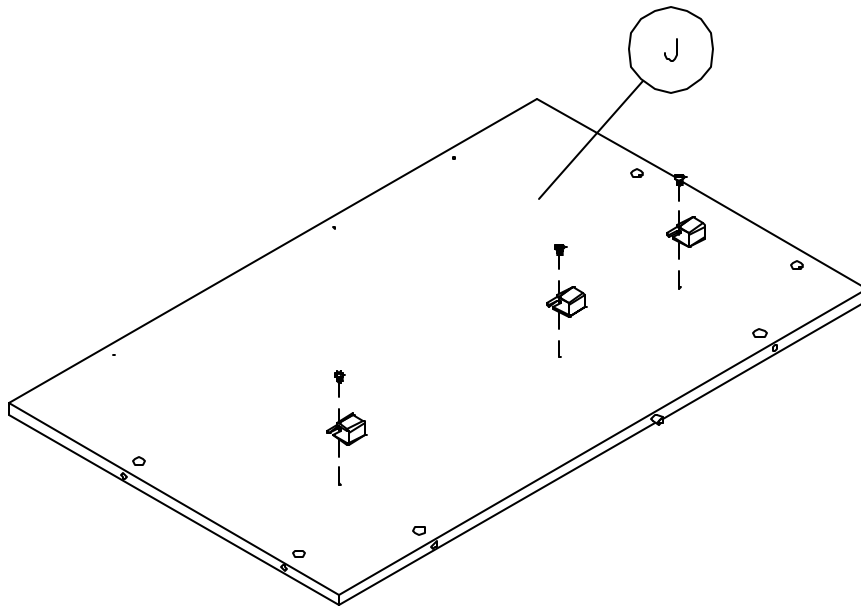

?
1
·
8
0
0
·
9
5
0
·
4
7
8
2

6

H35251  [3]

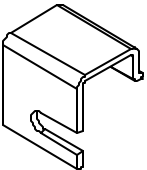
H117285  [3]

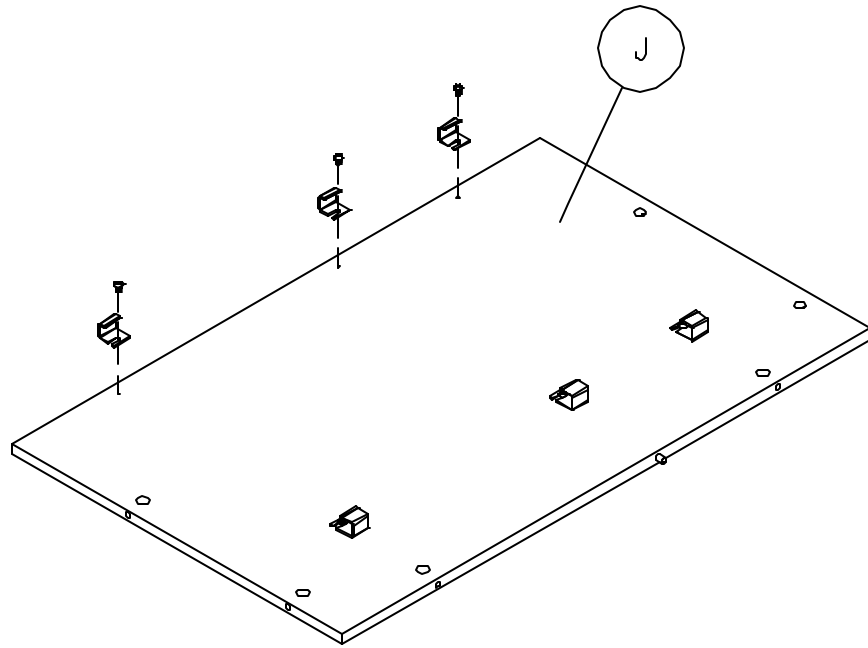

?

1
·
8
0
0
·
9
5
0
·
4
7
8
2



H71659

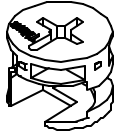

[2]

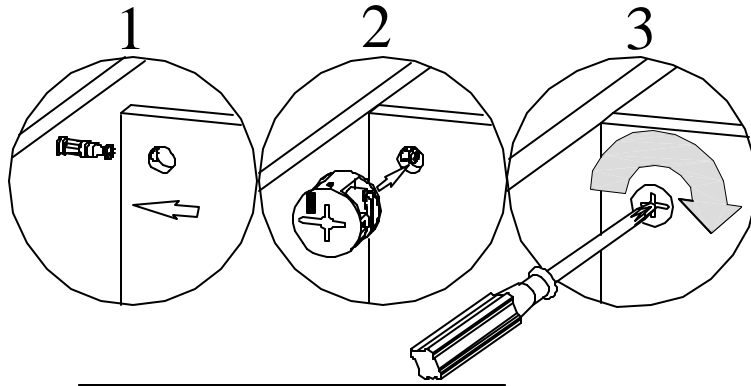

7

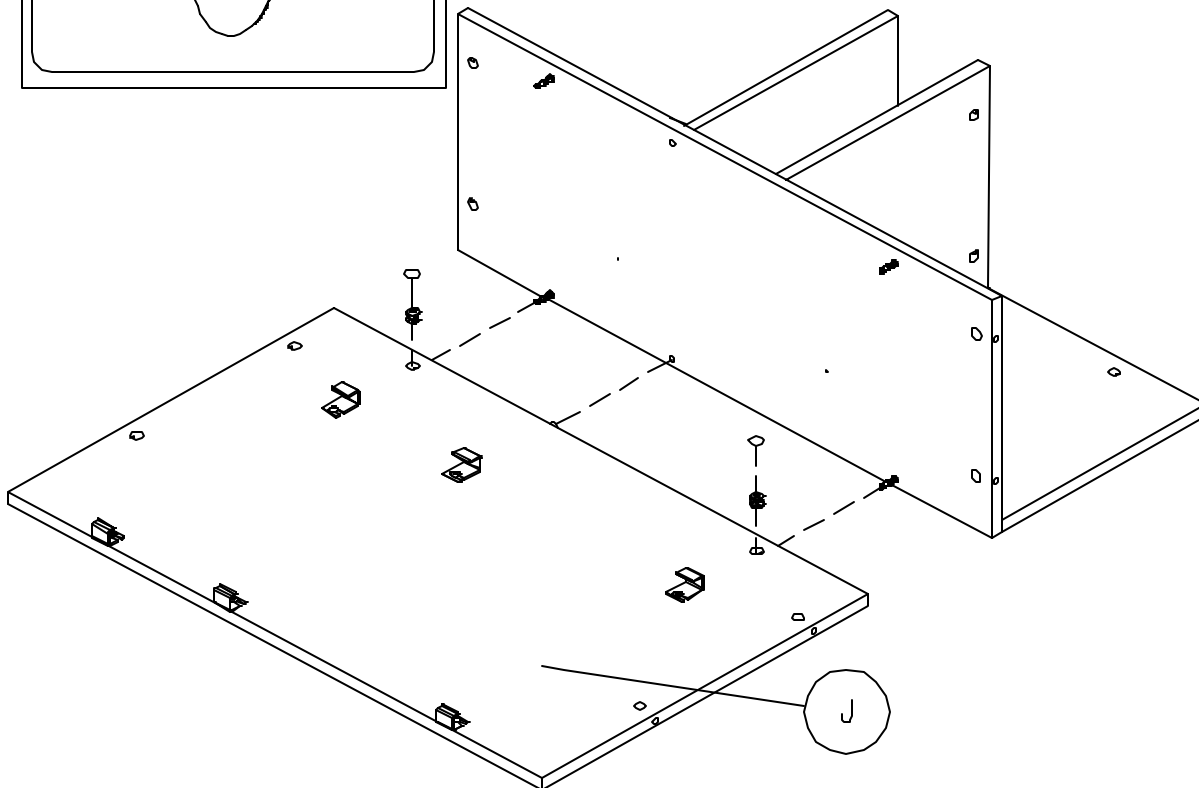
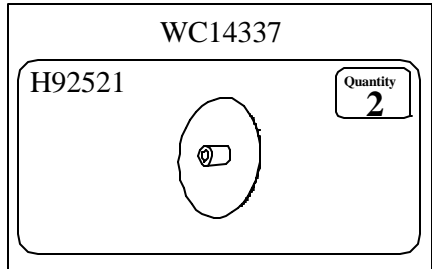
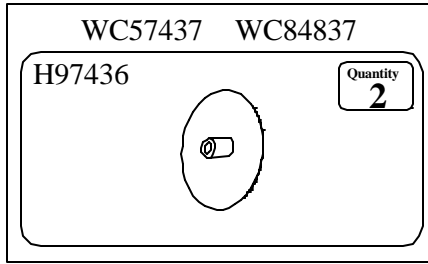
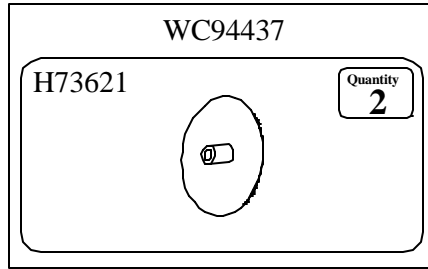
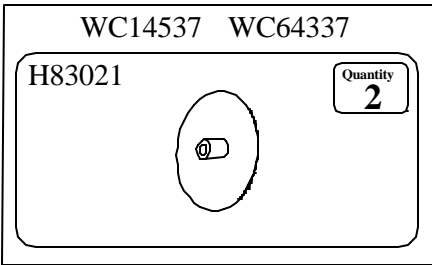
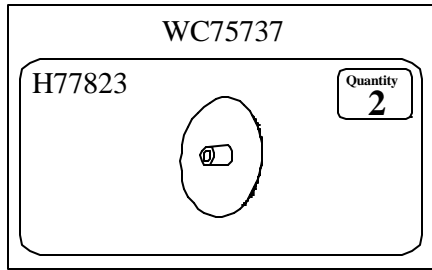

?
1
·
8
0
0
·
9
5
0
·
4
7
8
2

A133504



8

H72988  [4]

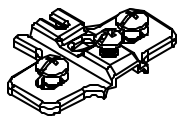
H126364  [2]

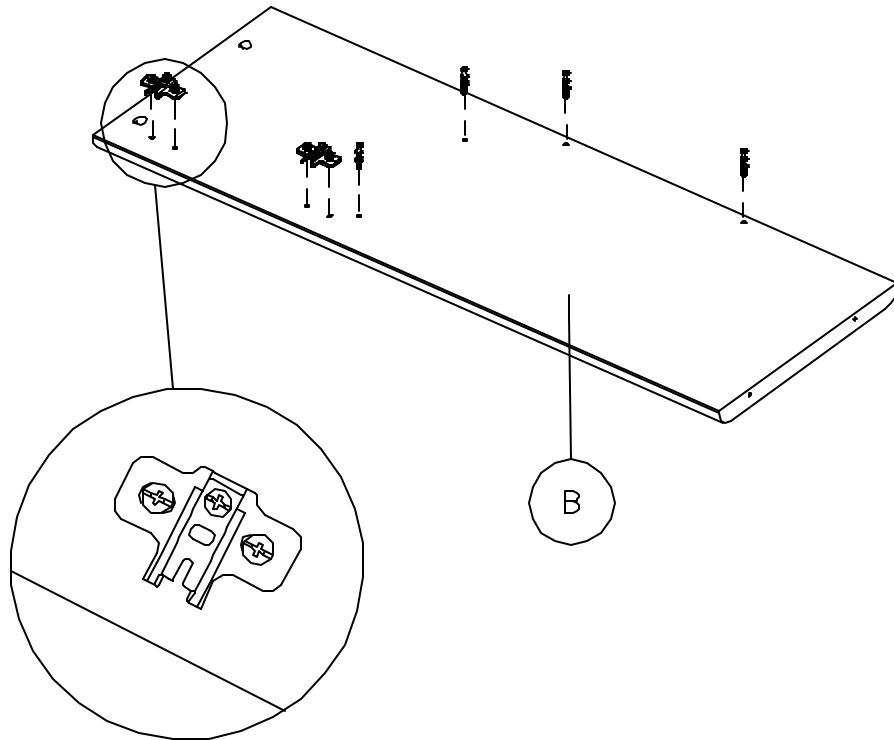
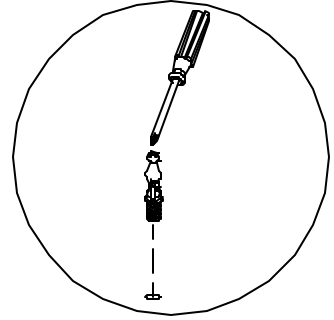

?

1
·
8
0
0
·
9
5
0
·
4
7
8
2

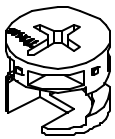

H71659  [4]

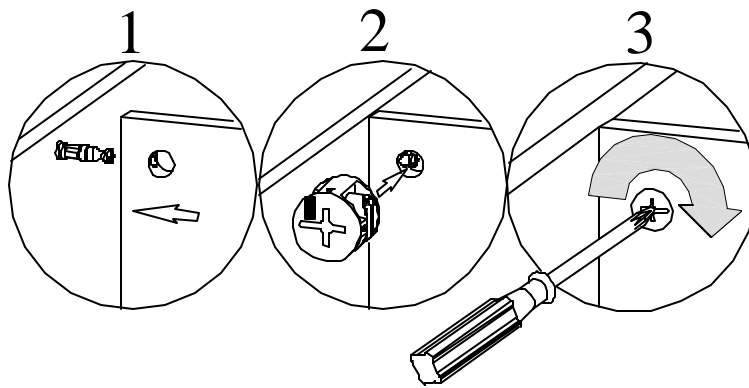

WC75737
H77823 Quantity 2



WC14537 WC64337
H83021 Quantity 2



WC14337
H92521 Quantity 2



WC94437
H73621 Quantity 2

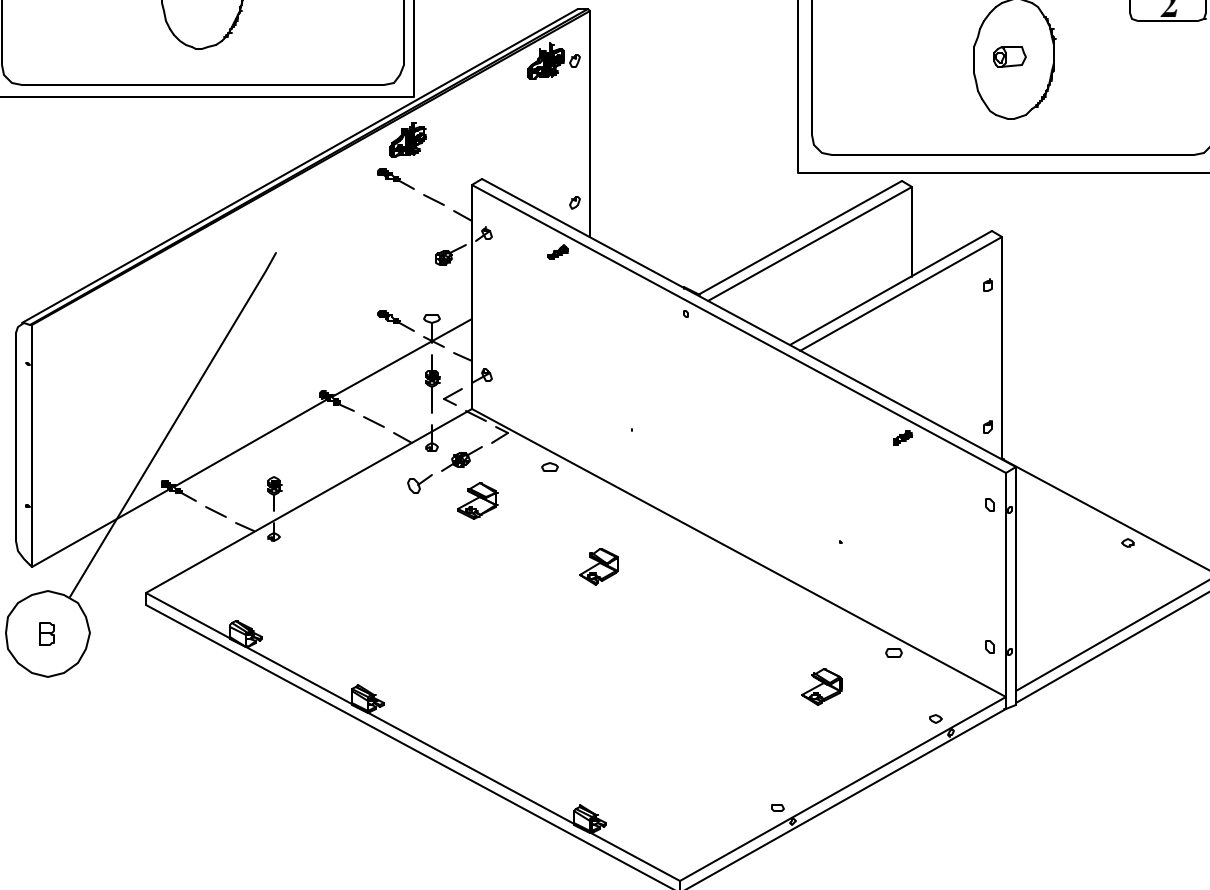

WC57437 WC84837
H97436 Quantity 2

9

?
1
·
8
0
0
·
9
5
0
·
4
7
8
2

A133504



H72988 [4]



H126364 [2]

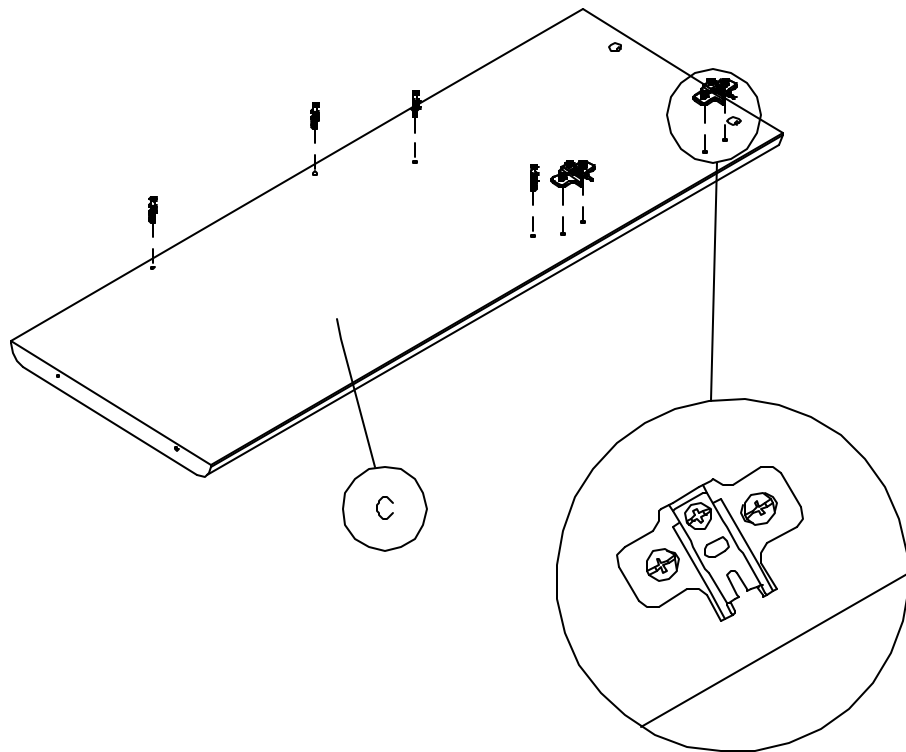
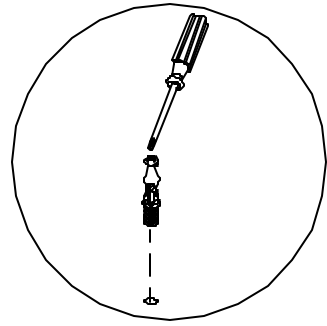
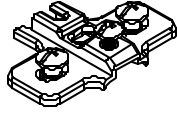

?

1
·
8
0
0
·
9
5
0
·
4
7
8
2

H71659

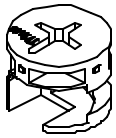

[4]

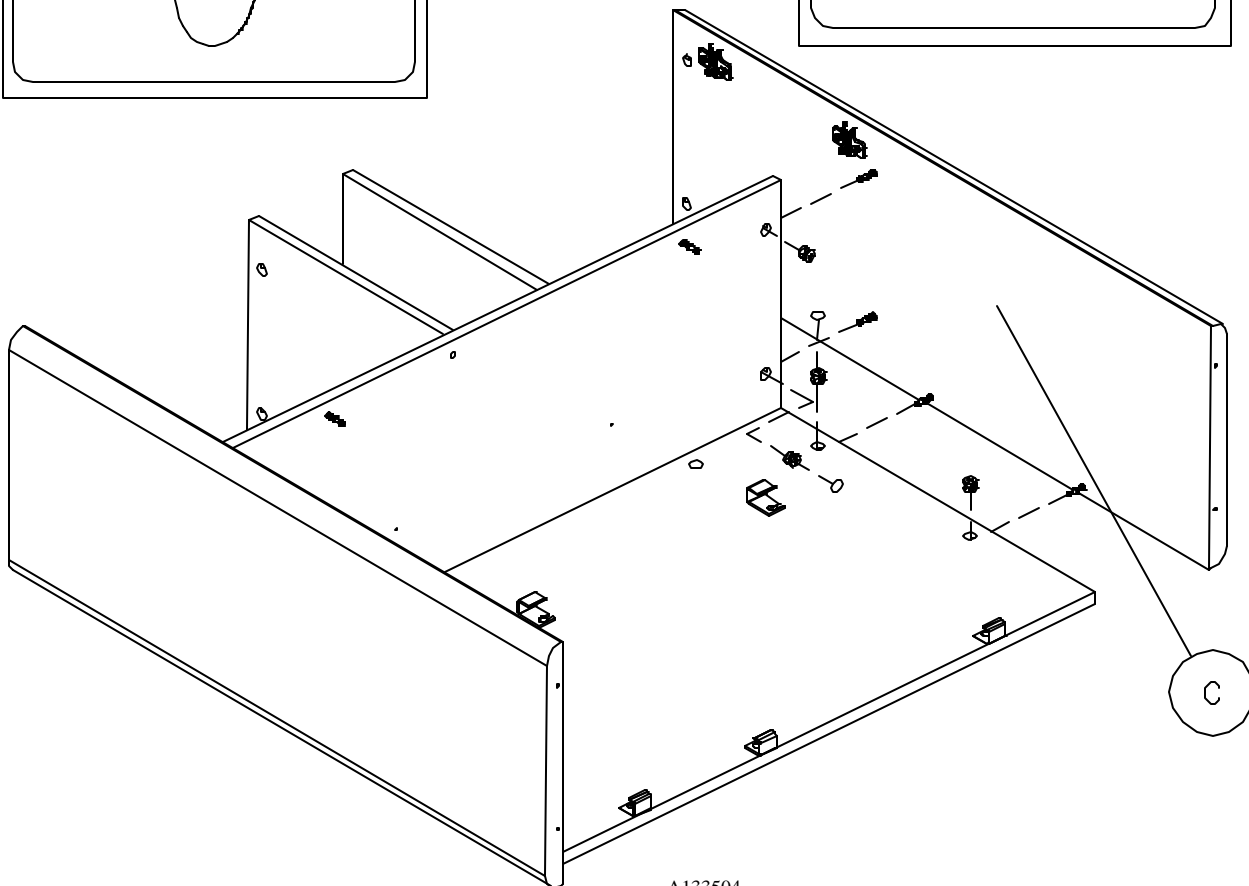
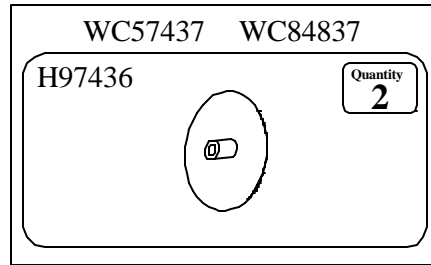
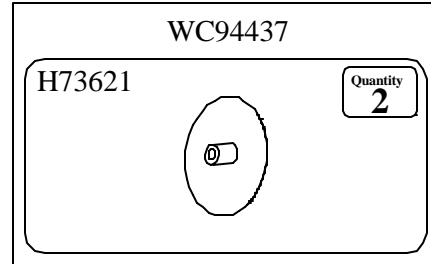
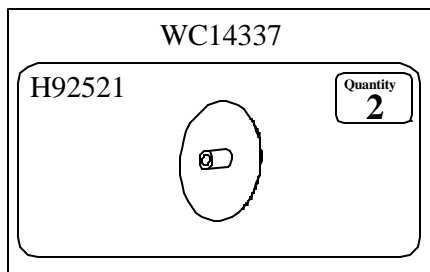
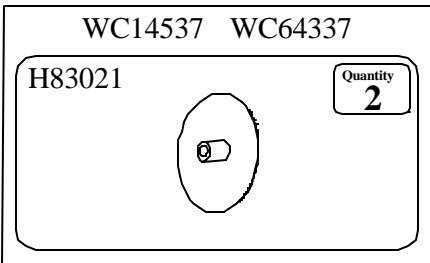
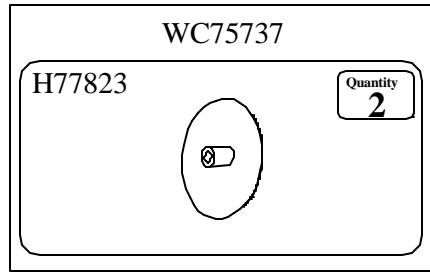
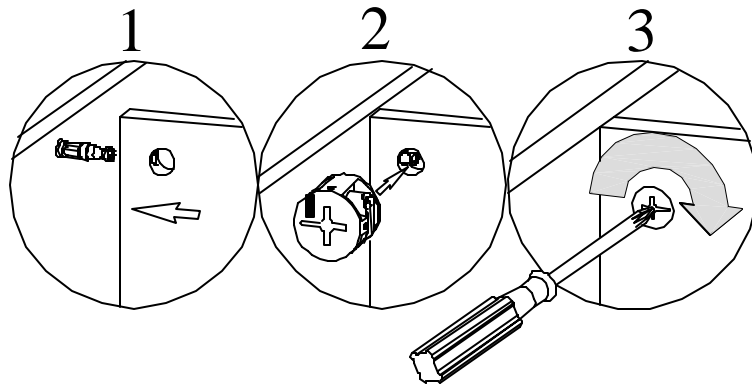

?
1
·
8
0
0
·
9
5
0
·
4
7
8
2

12

H72988 [10]

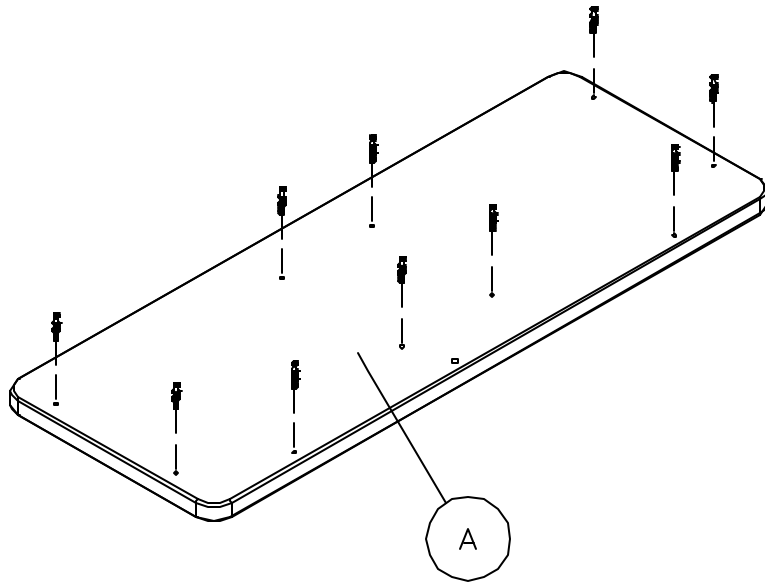
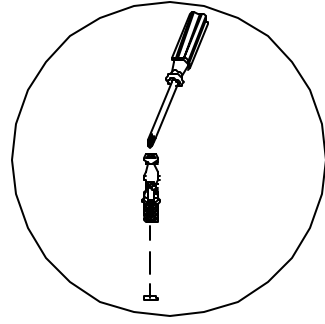
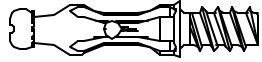

?

1
·
8
0
0
·
9
5
0
·
4
7
8
2



H71659

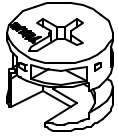

[10]

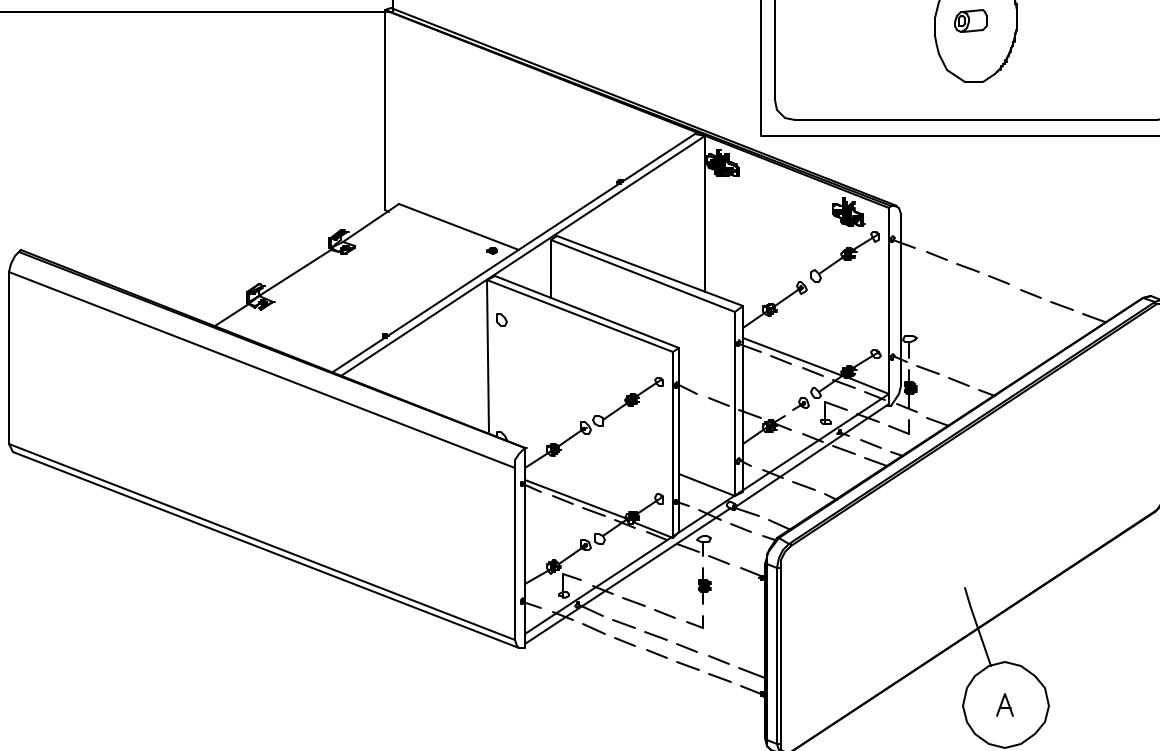
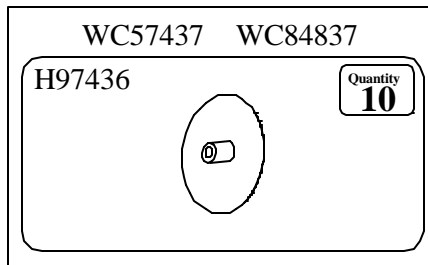
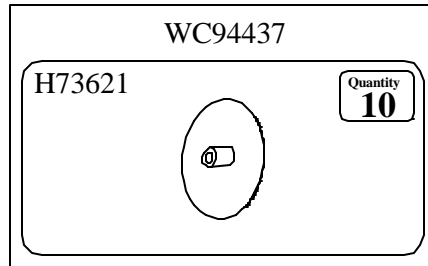
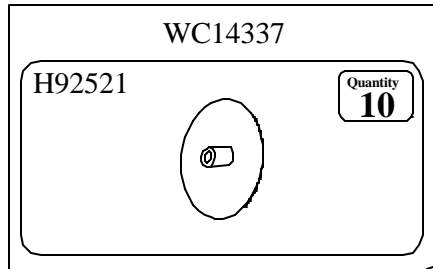
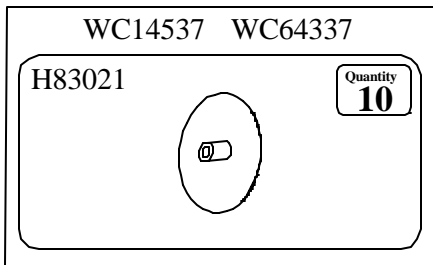
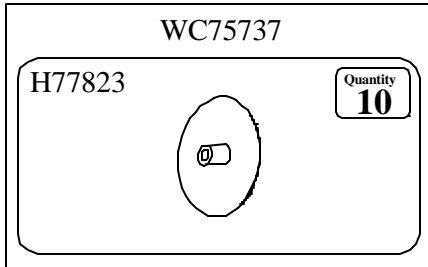
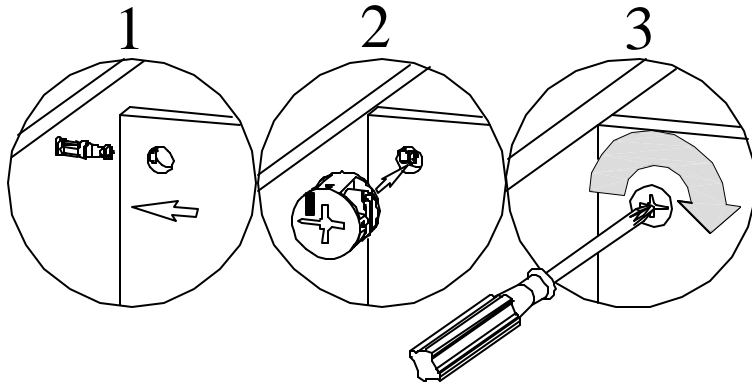

?
1
·
8
0
0
·
9
5
0
·
4
7
8
2

14

H38169



[1]

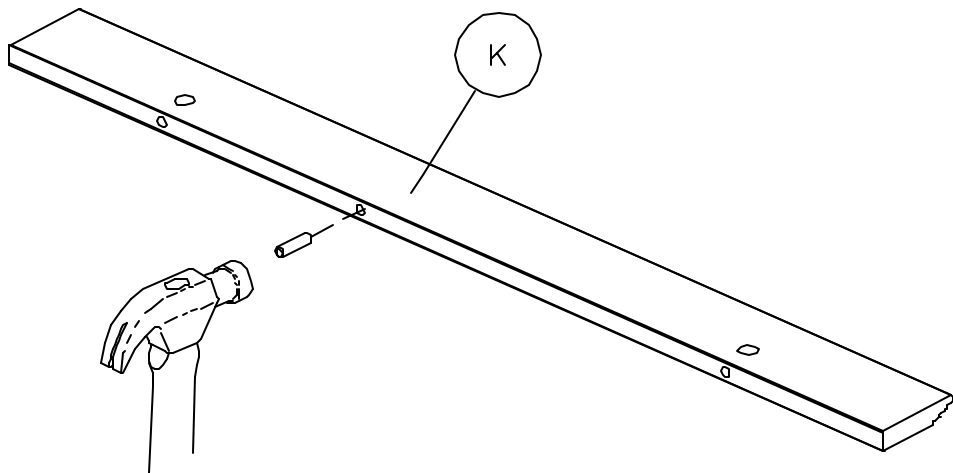

?

1

·

8

0

0

·

9

5

0

·

4

7

8

2

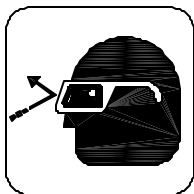

H71659

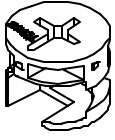

[2]

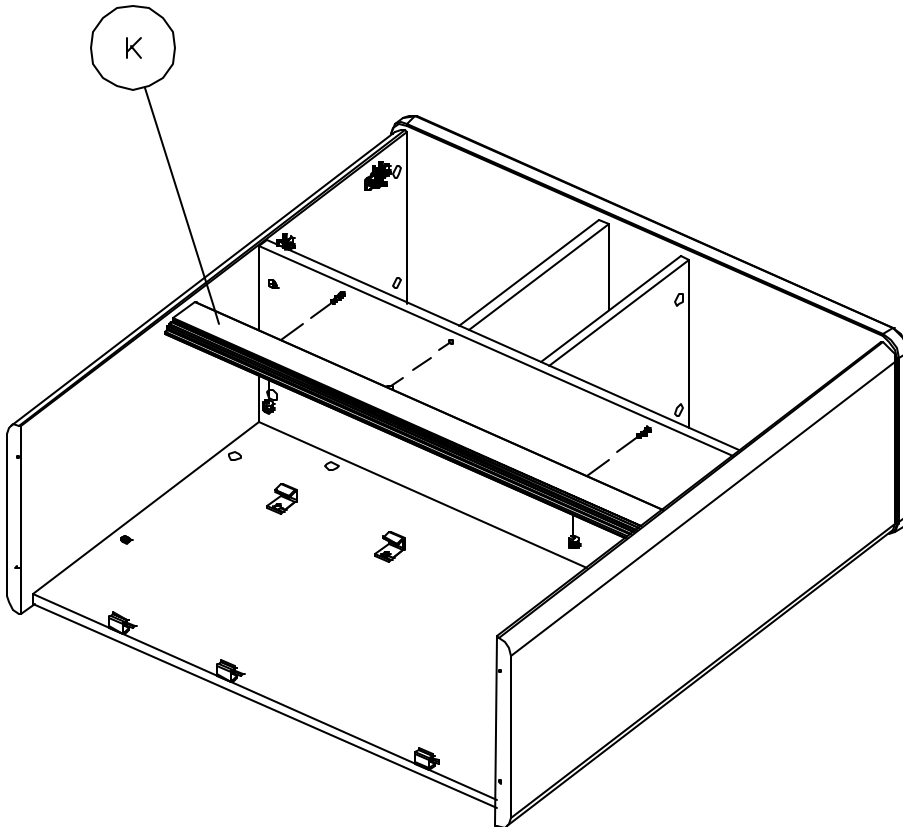
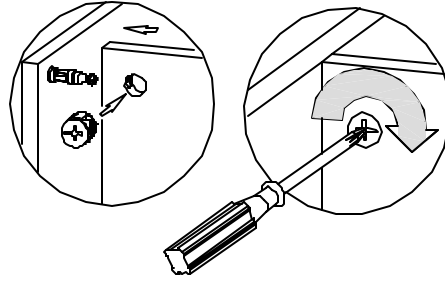

?
1
·
8
0
0
·
9
5
0
·
4
7
8
2

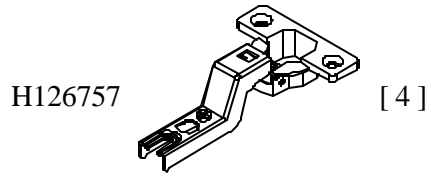

?
1
·
8
0
0
·
9
5
0
·
4
7
8
2

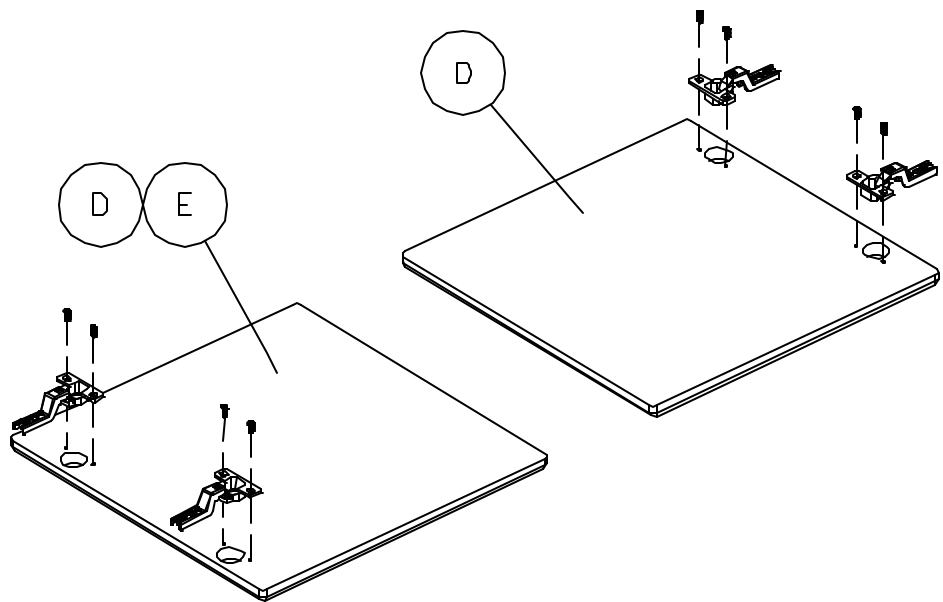

WC75737

H83431 Quantity 4



8 x 1.25

H83034 Quantity 2



WC14537

H92138 Quantity 4



8 x 1.125"

H91373 Quantity 2

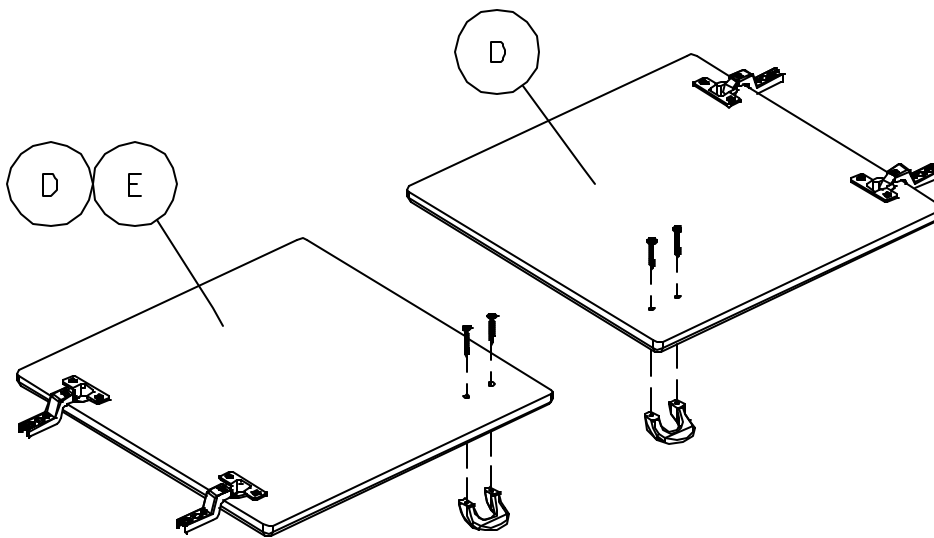
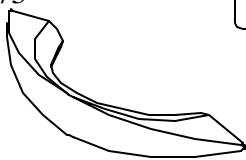

?
1
·
8
0
0
·
9
5
0
·
4
7
8
2

H29206



[1]

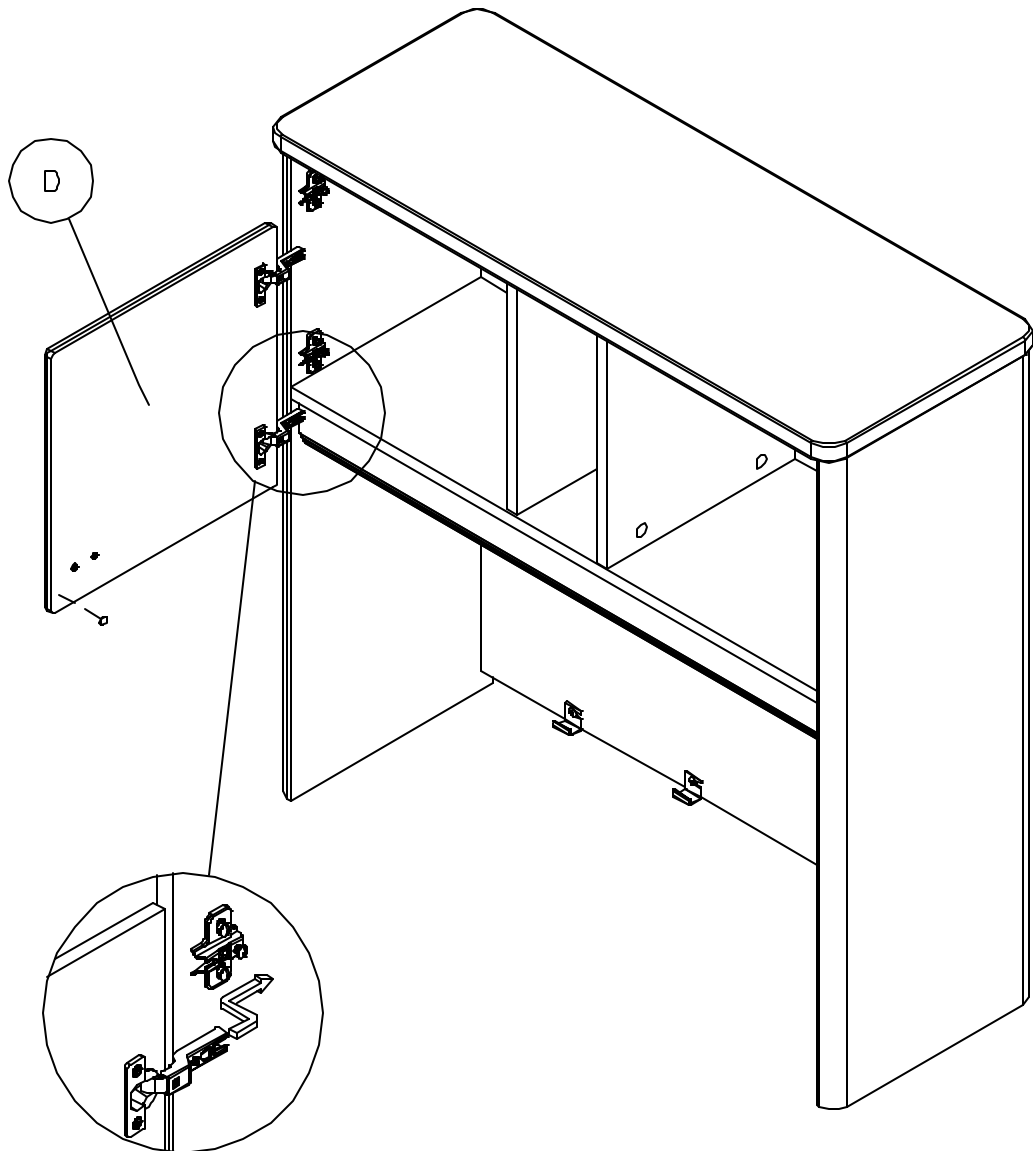
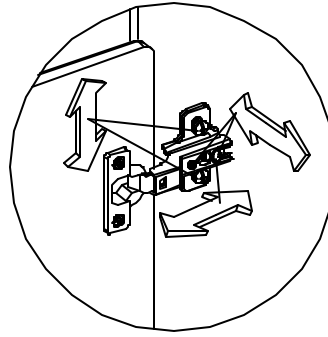

?
1
·
8
0
0
·
9
5
0
·
4
7
8
2



H29206



[1]

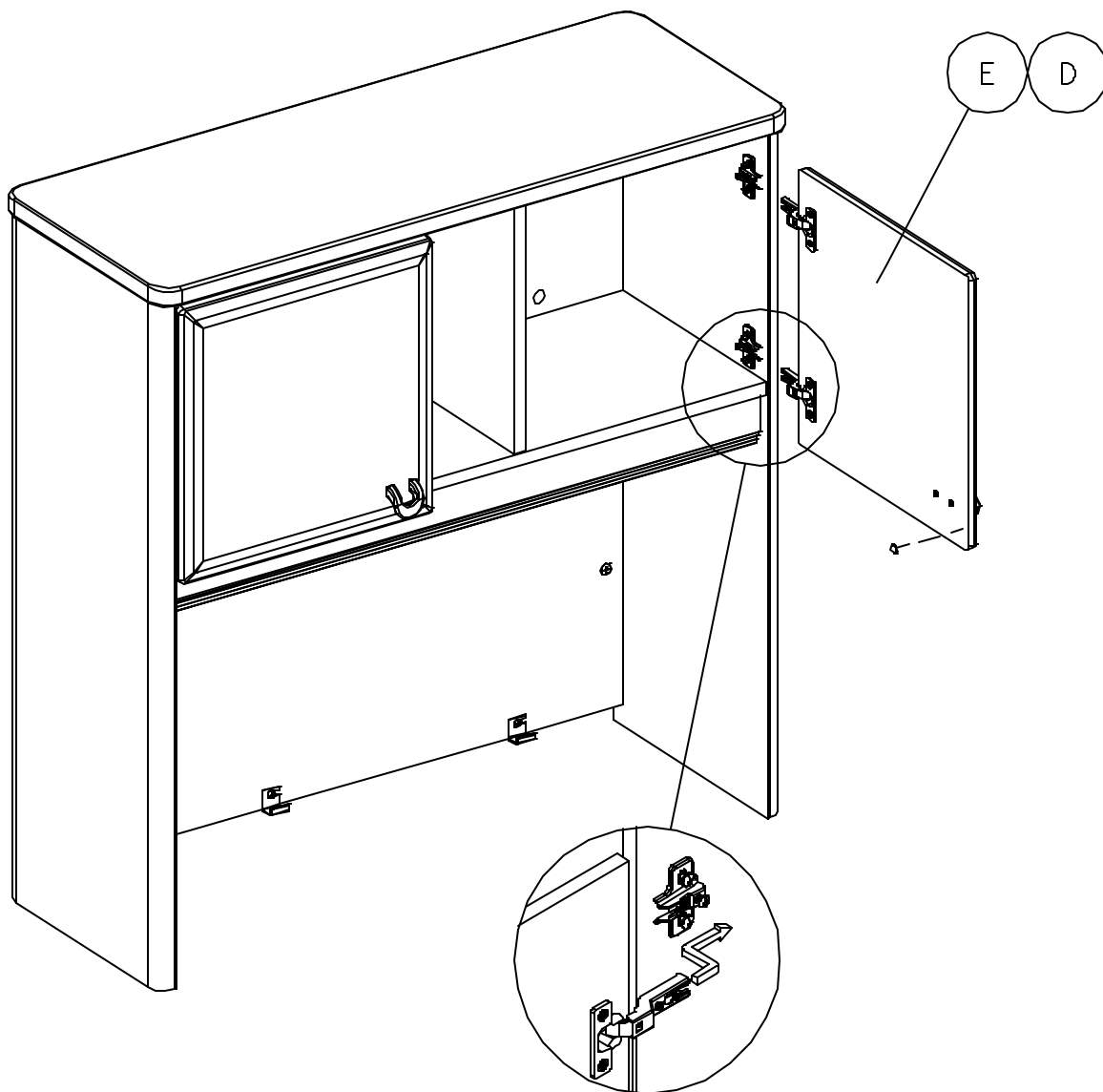
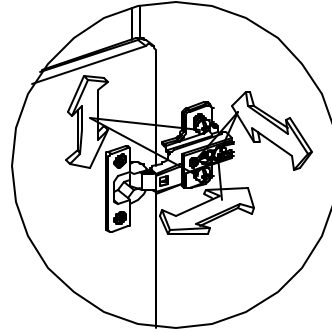

19

?
1
·
8
0
0
·
9
5
0
·
4
7
8
2

A133504



H23491

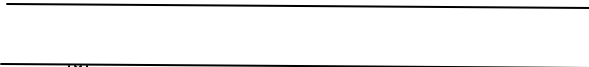
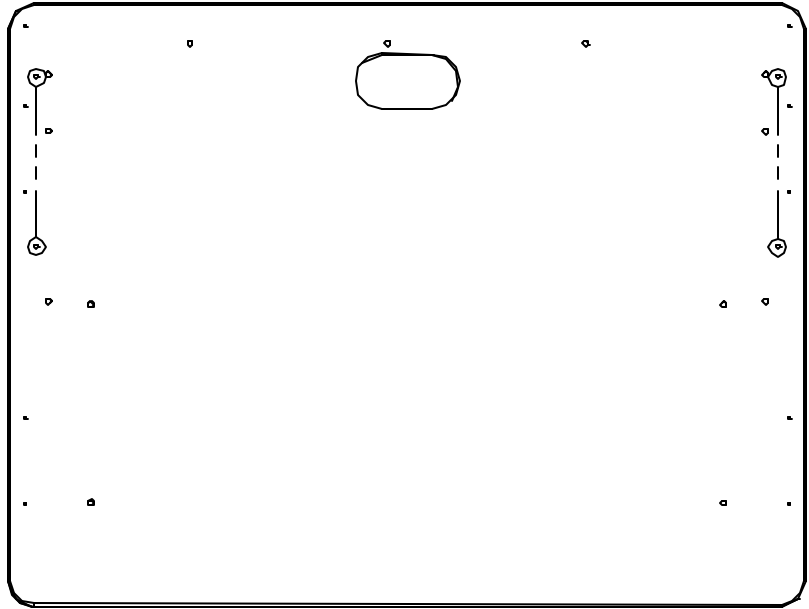
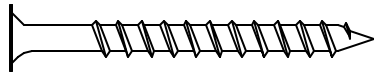

?

1

2

3

1
·
8
0
0
·
9
5
0
·
4
7
8
2

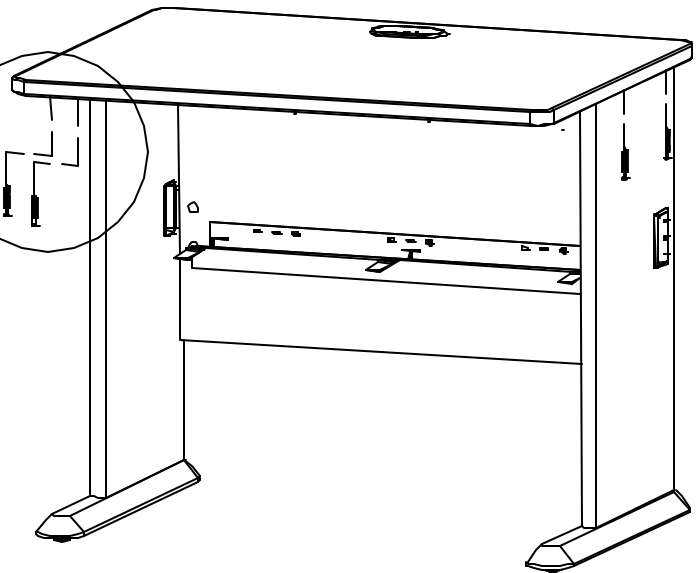
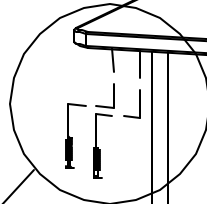
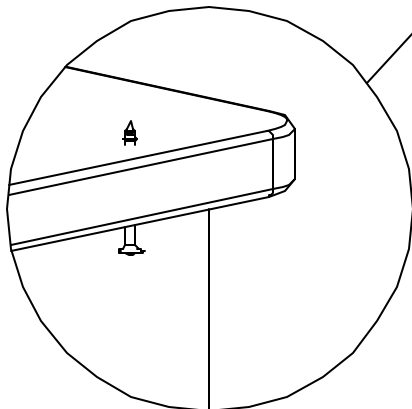

H23491



WARNING

This hutch is intended to be attached to base units that are interconnected in L- or U-shaped workstations. If the hutch is not attached to interconnected base units in this manner, then the combined units must be placed against a wall. Improper assembly or usage could cause instability, tip over, and/or serious injury.

Any questions, please call 1-888-592-0083.

Este gabinete ha sido diseñado para ser conectado a otras unidades de trabajo en forma de "L" o "U". Si este gabinete no está sujeto a unidades de bases interconectadas, las unidades combinadas siempre deben ser colocadas contra una pared. Si tiene preguntas con relación a este procedimiento, favor de llamar 1-888-592-0083

Ce vaisselier est supposé être attaché aux unités interconnectés, alors les unités assemblés doivent être mises contre un mur. Pour toutes questions, veuillez appeler le 1-888-592-0083.

An assistant is required.
Es necesario un ayudante.
Un assistant est nécessaire.

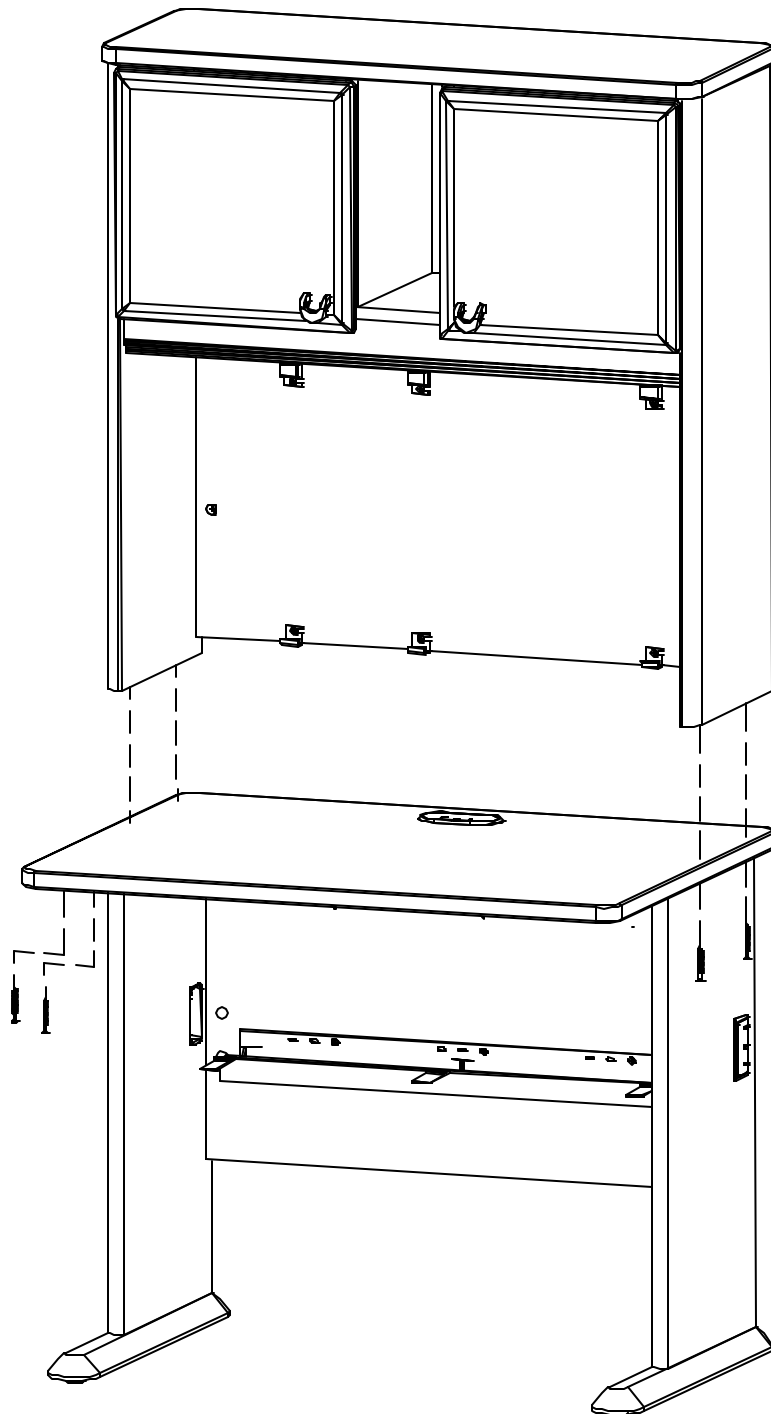

?
1
·
8
0
0
·
9
5
0
·
4
7
8
2

?

1

·

8

0

0

·

9

5

0

·

4

7

8

2

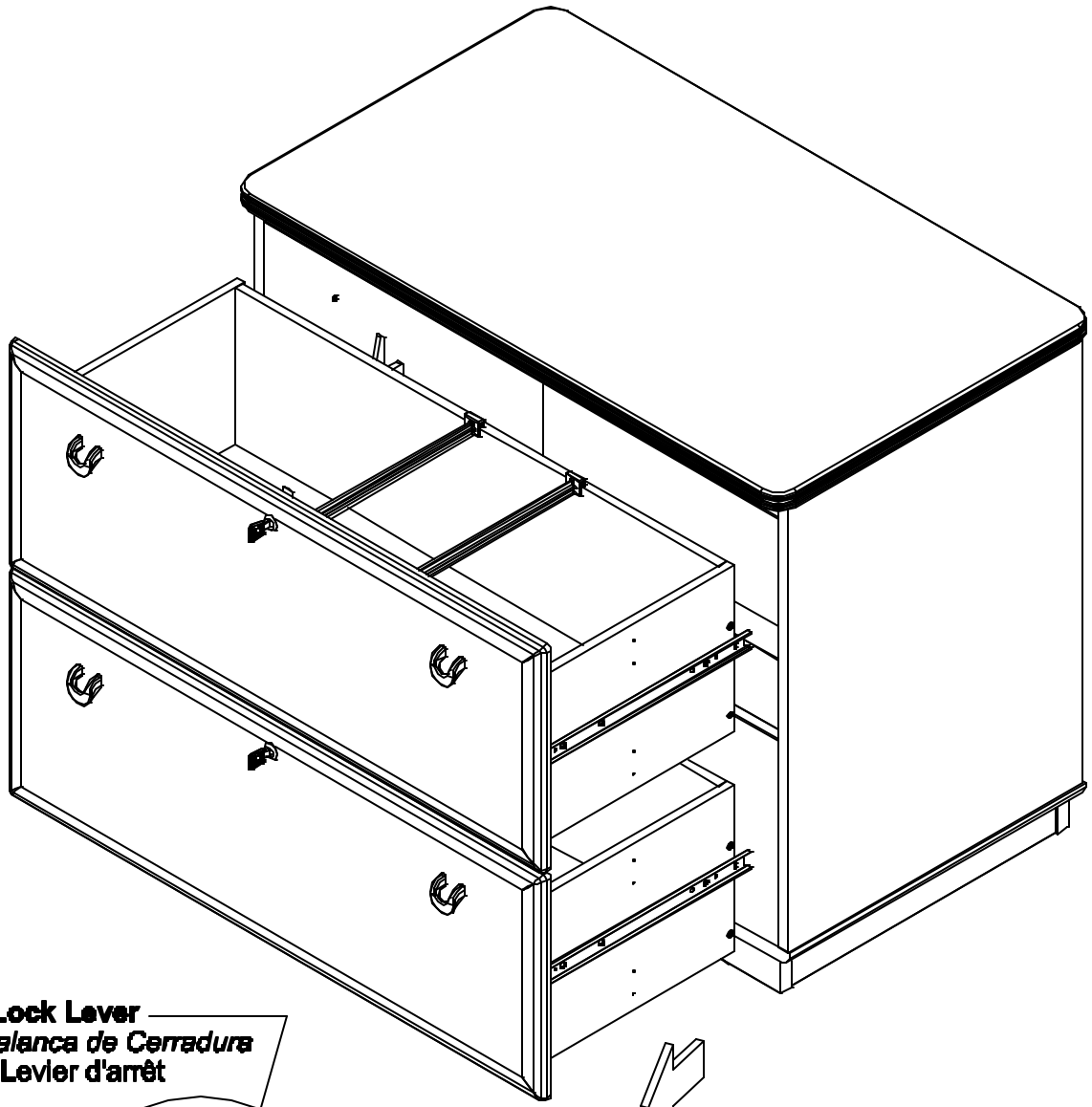

Lock Lever
Palanca de Cerradura
Levier d'arrêt

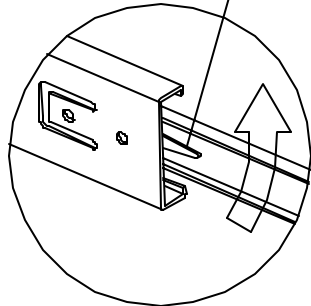

Move lock lever on the drawer runner as shown and separate drawer runner from drawer slide.
Mueva Palanca de la Cerradura en la coredera como se muestra y separe la coredera del deslizable.
 Relever le Levier d'arrêt sur la coulisse pour tirer et séparez le coulisseu de la coulisse tel que montré.

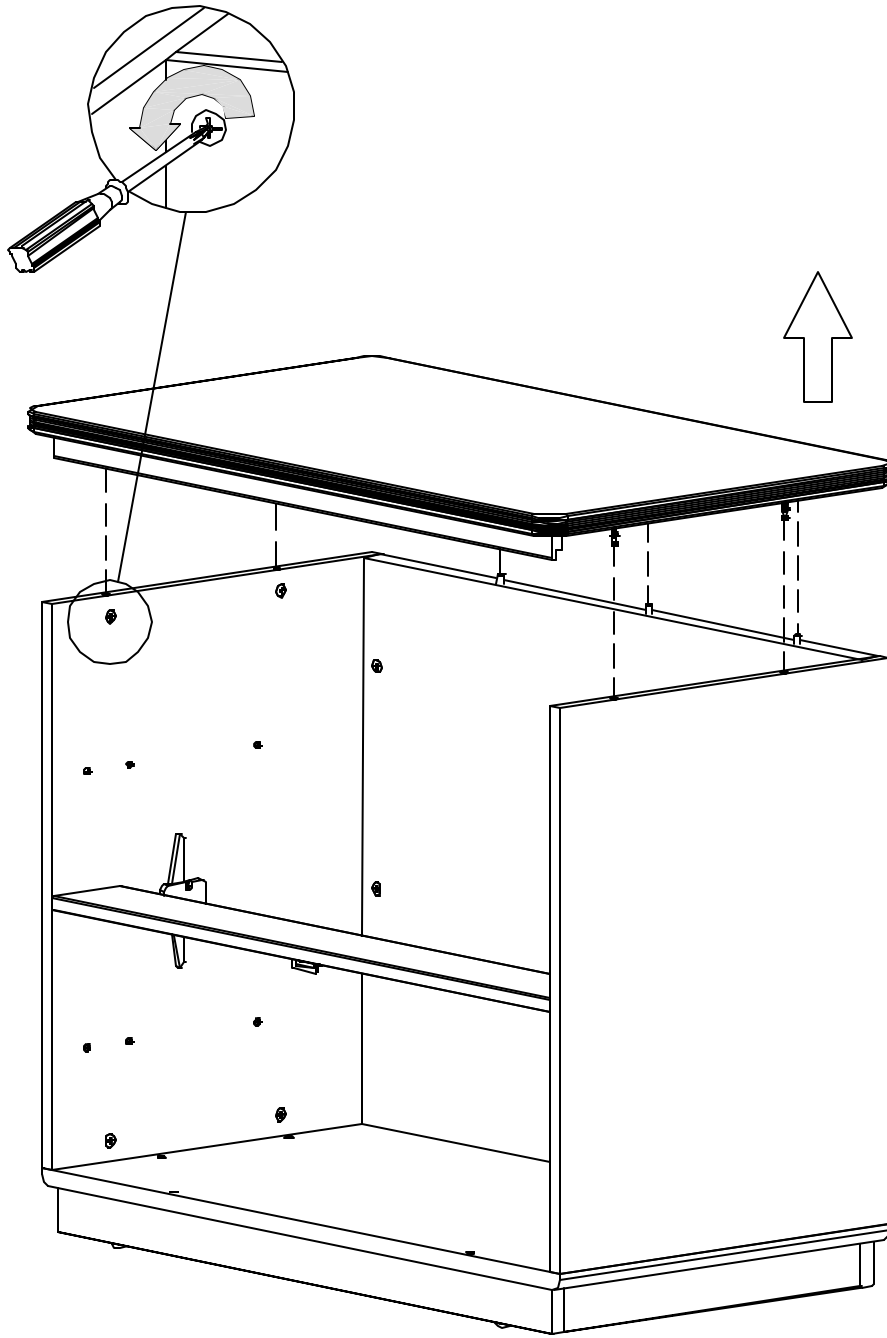

?
1
·
8
0
0
·
9
5
0
·
4
7
8
2

H23491

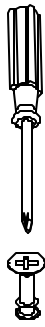
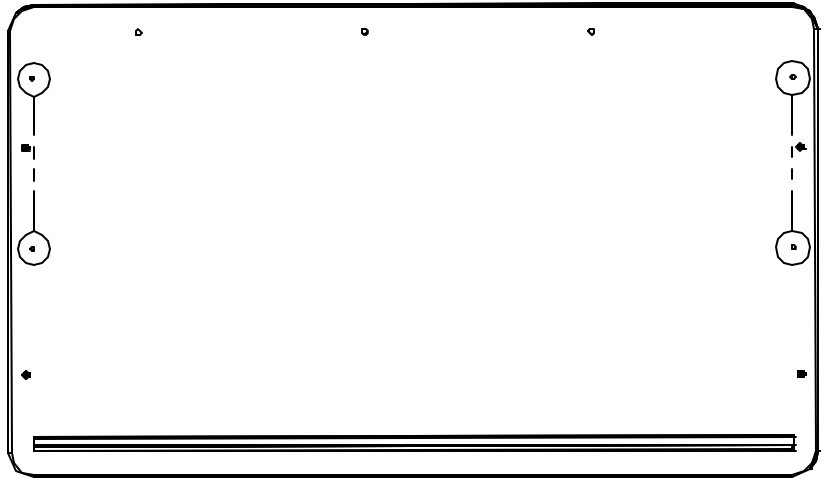

1

2

3

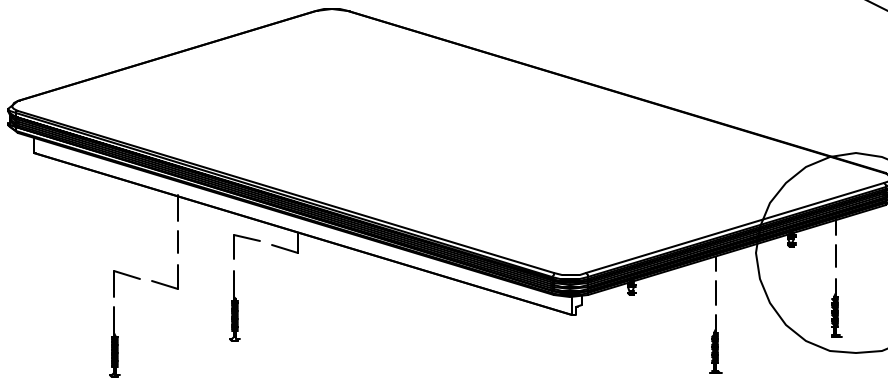
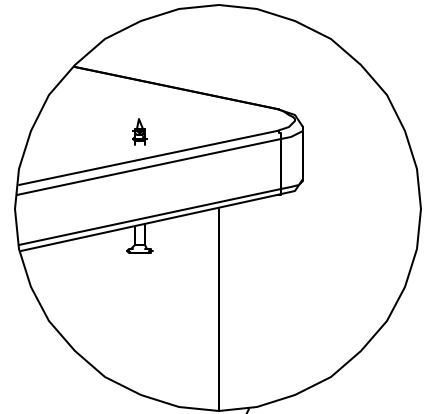

?

1
·
8
0
0
·
9
5
0
·
4
7
8
2



H23491



[4]

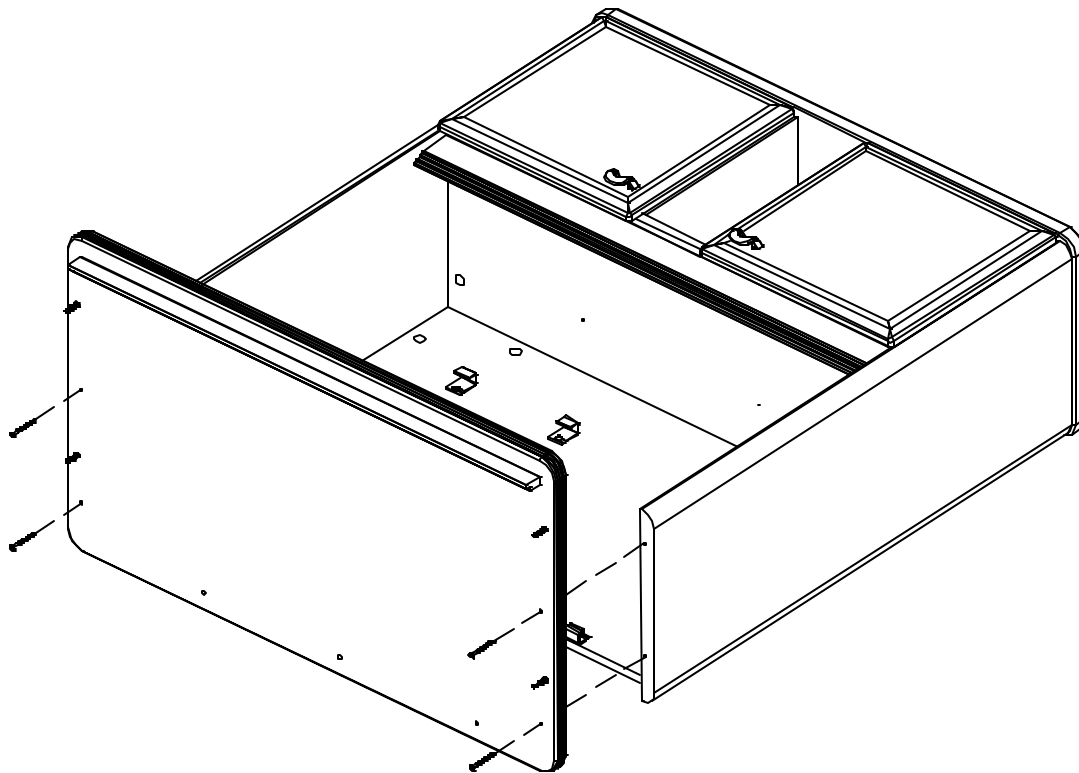

?
1
·
8
0
0
·
9
5
0
·
4
7
8
2

**WARNING**

This hutch is intended to be attached to base units that are interconnected in L- or U-shaped workstations. If the hutch is not attached to interconnected base units in this manner, then the combined units must be placed against a wall. Improper assembly or usage could cause instability, tip over, and/or serious injury.

Any questions, please call 1-888-592-0083.

Este gabinete ha sido diseñado para ser conectado a otras unidades de trabajo en forma de "L" o "U". Si este gabinete no está sujeto a unidades de bases interconectadas, las unidades combinadas siempre deben ser colocadas contra una pared. Si tiene preguntas con relación a este procedimiento, favor de llamar 1-888-592-0083

Ce vaisselier est supposé être attaché aux unités interconnectés, alors les unités assemblés es doivent être mises contre un mur. Pour toutes questions, veuillez appeler le 1-888-592-0083.

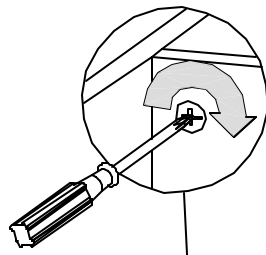

An assistant is required.
Es necesario un ayudante.
Un assistant est nécessaire.

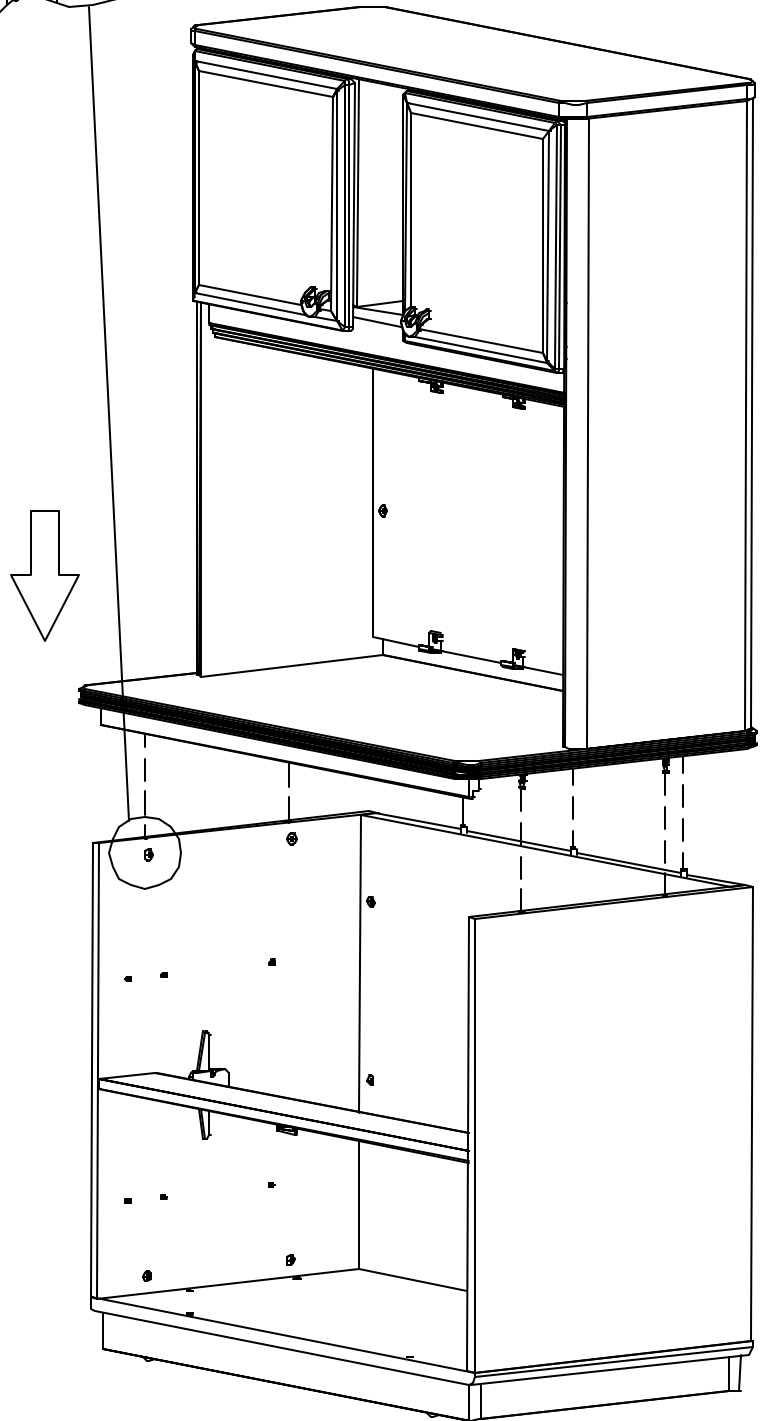

?

1

.

8

0

0

.

9

5

0

.

4

7

8

2

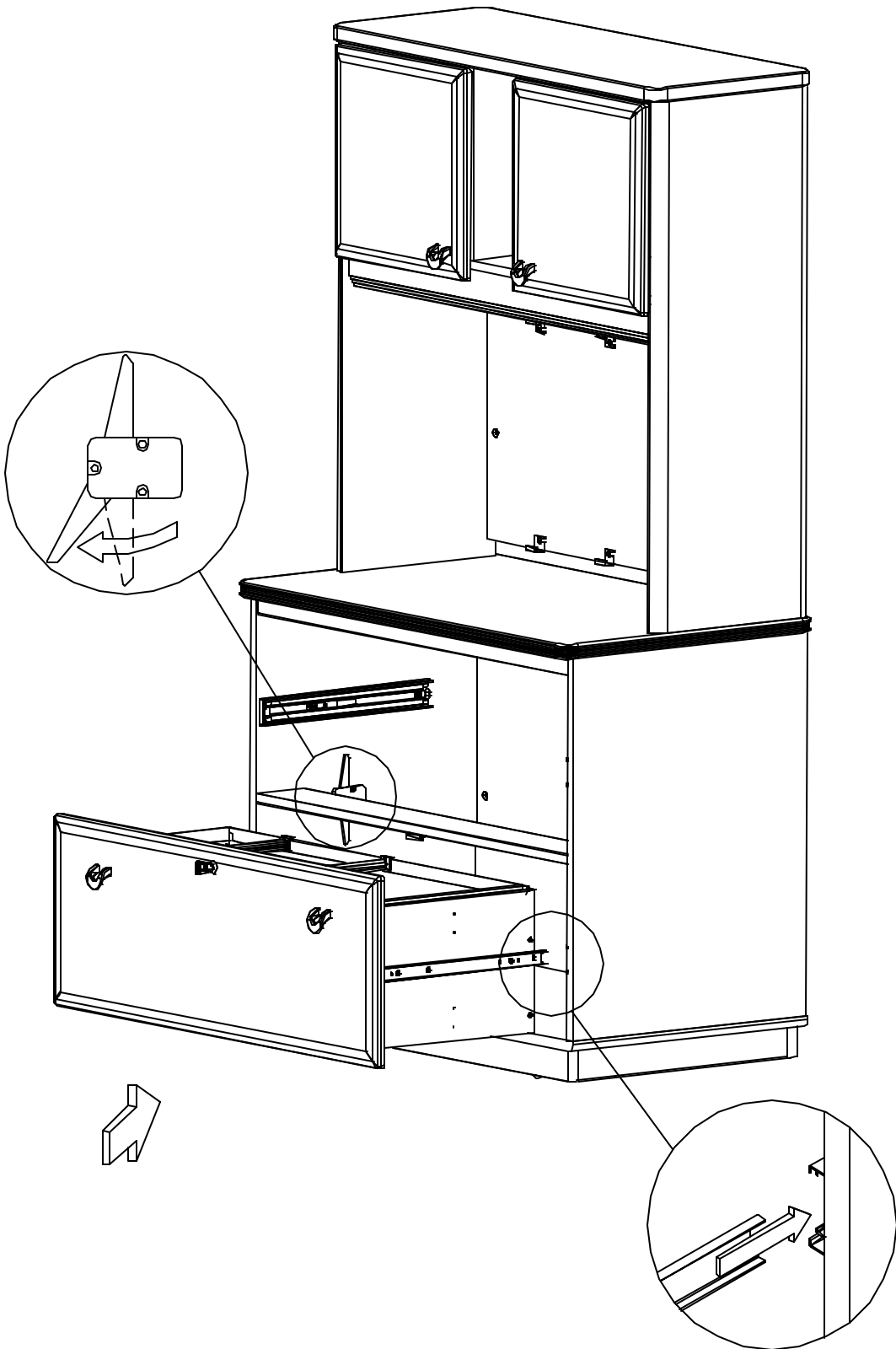

?
1
·
8
0
0
·
9
5
0
·
4
7
8
2

A133504



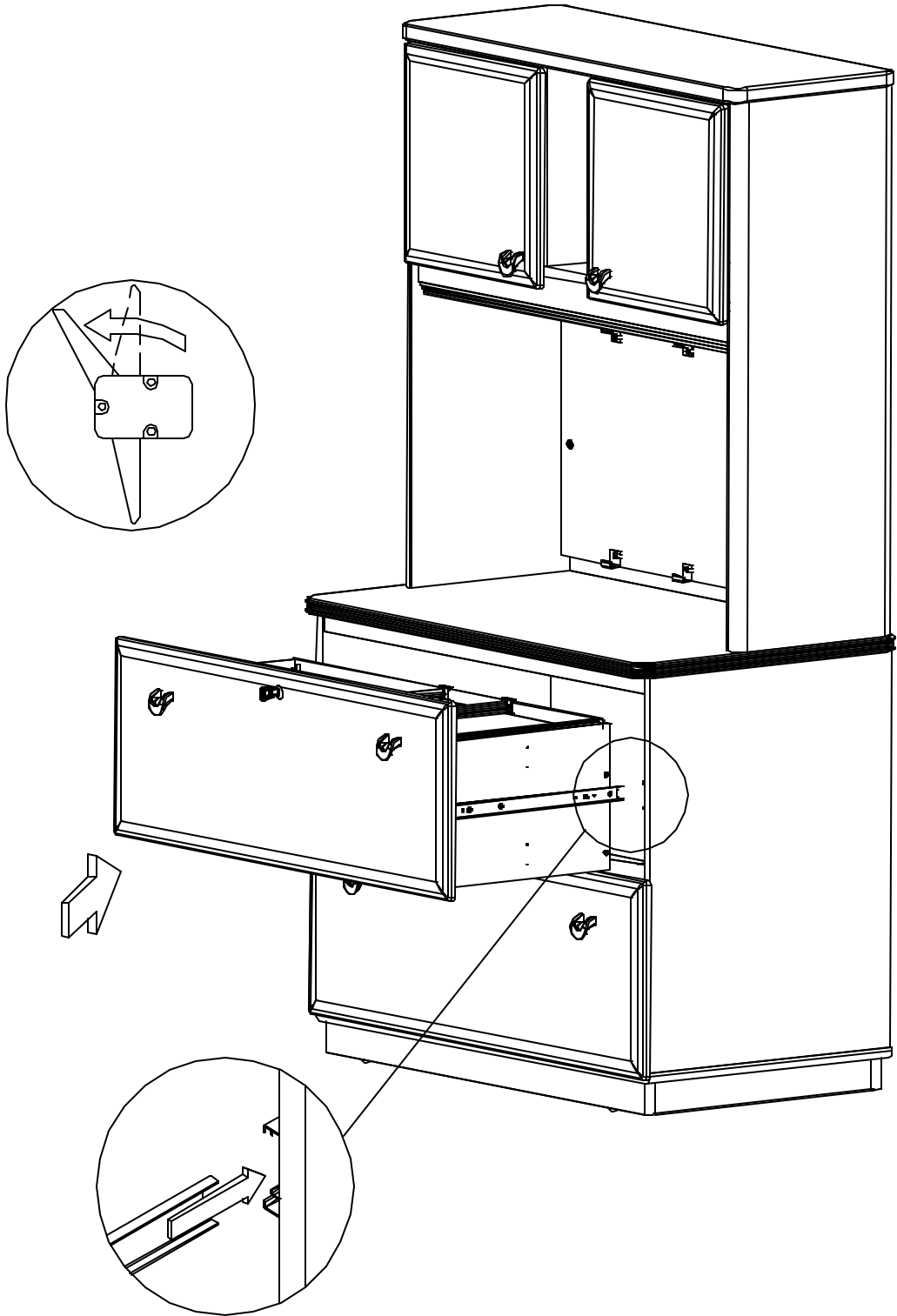

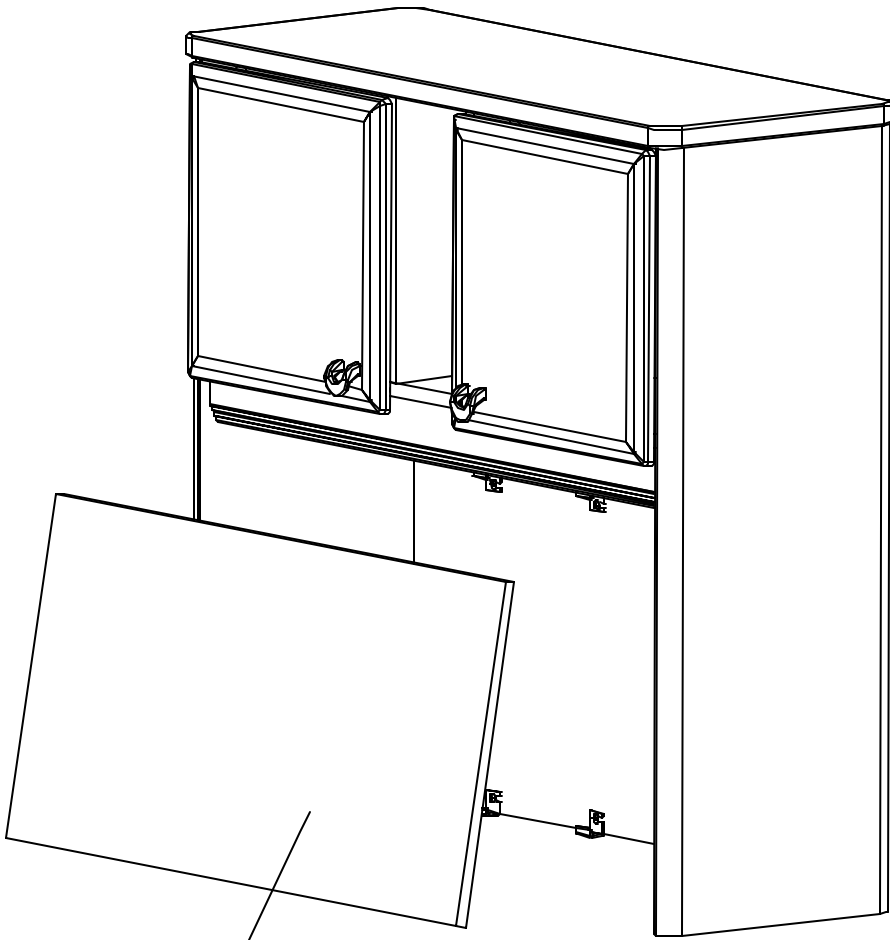

L

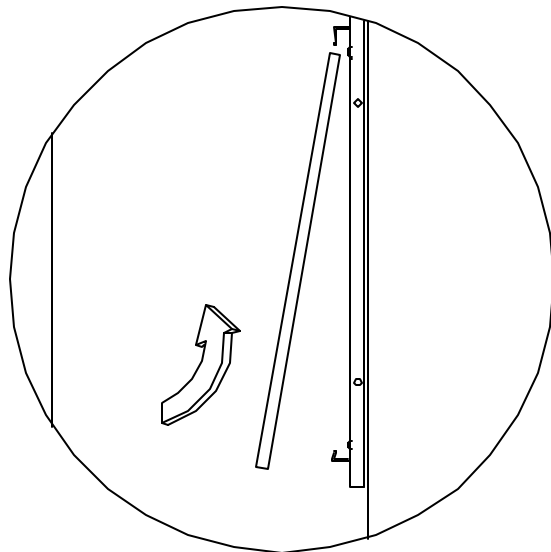

A133504

?

1
·
8
0
0
·
9
5
0
·
4
7
8
2



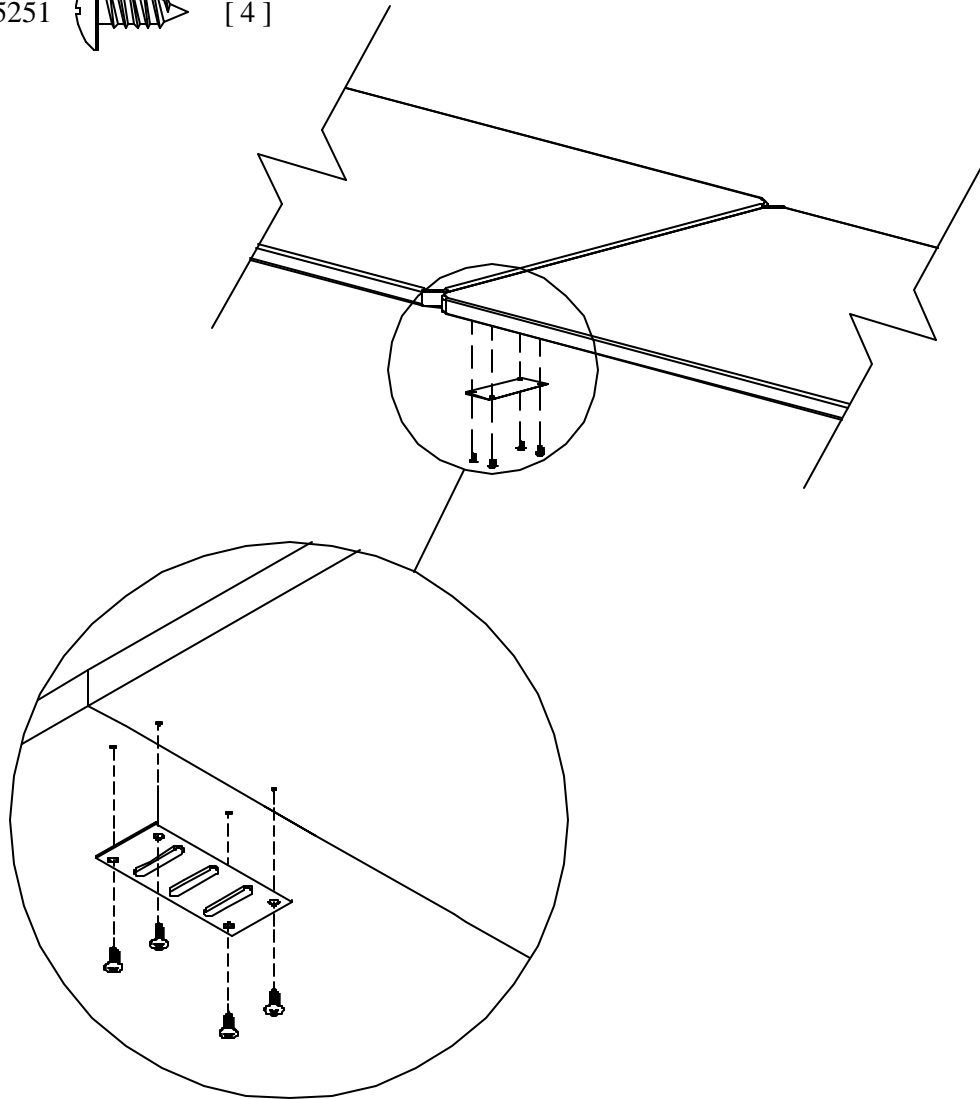
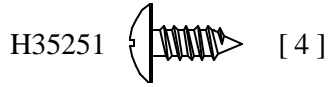
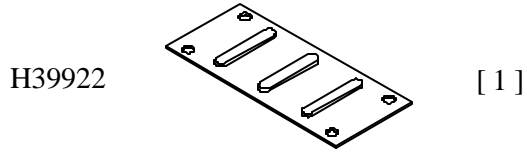

?

1
.
8
0
0
.
9
5
0
.
4
7
8
2

When used with other desk, attach desk tops together with straps provided.

Cuando esta unidad es usada con otro escritorio, los toques de los escritorios de ben sersujetados con la banda de metal suministrada.

Lors de l'utilisation avec un autre bureau, attachez le haut des bureau avec la sangle fournie.

