

MODEL WC12914  
WC24414  
WC36714  
WC48514  
WC60314  
WC72414



Can we help you ?

THE BUSH FURNITURE

# difference

- QUALITY
- INNOVATION
- SERVICE
- VALUE

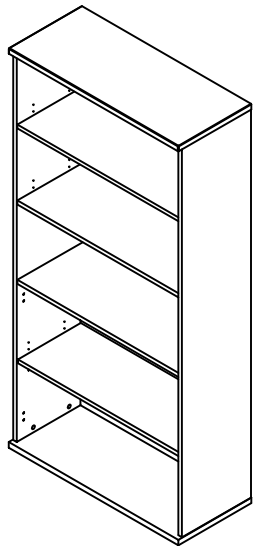

**Bush**<sup>®</sup>  
BUSINESS FURNITURE

***Thank you** for purchasing this Bush Business Furniture product. We trust that you will be completely satisfied with your product for many years to come. Bush Business Furniture products are backed by a 10 year warranty and crafted with today's styles in mind **for the way you live.***

***Gracias** por comprar este producto de Bush Business Furniture. Confiamos que usted estará completamente satisfecho con su mueble por muchos años. Productos de Bush Business Furniture tienen 10 años de garantía y son diseñados con los estilos de hoy en mente **para la manera que usted vive.***

***Merci** d'avoir acheté ce produit Furniture Business Bush. Nous comptons sur votre entière satisfaction avec votre produit au long des années à venir. Les produits furniture Business Bush sont garantis pour une période de 10 ans et sont conçus dans les styles d'aujourd'hui gardant à l'esprit **votre mode de vie.***

Sincerely,

*Paul Bush*

Paul Bush  
President, Bush Industries

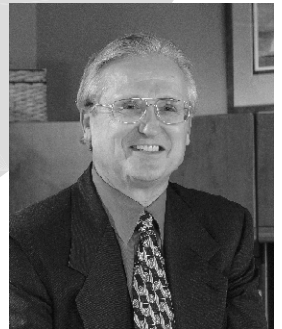

**10** Year  
WARRANTY

# Bush™

**BUSINESS FURNITURE**



M - F 7a.m. - 11p.m.  
Sat. 9a.m. - 5:30p.m.  
Sun. 9a.m. - 5:30p.m.  
(Except Holidays)

1-800-950-4782 USA/CANADA  
95-800-950-4782 MEXICO  
Se habla Español

Outside USA/ CANADA/ MEXICO:  
001-716-665-2510 Ext. 5900

Email us:

[ConsumerService@BushIndustries.com](mailto:ConsumerService@BushIndustries.com)



[www.bushfurniture.com](http://www.bushfurniture.com)

# 10 Year

**WARRANTY**

## IT'S AS EASY AS 1,2,3

### Assembly tips:

1. Read the instructions and become familiar with the parts.
2. To protect floors, assemble the furniture on the carton.
3. An assistant may be helpful.
4. Use of power tools is not recommended.

### Consejos de Ensamblaje:

1. Lea las instrucciones y familiarícese con las partes.
2. Para proteger el piso, ensamble el mueble en el cartón.
3. Un asistente puede serle útil.
4. El uso de herramientas electricas no se recomienda.

### Assemblage:

1. Lisez les instructions et familiarisez-vous avec les pièces.
2. Afin de protéger vos sols, assemblez votre meuble sur un carton.
3. Il sera peut-être utile de vous faire aider.
4. L'utilisation d'outils électriques n'est par recommandée.

## CONSUMER SERVICE YOU CAN DEPEND ON

*Questions? Operators are standing by at our TOLL FREE help line to assist you with assembly, and if necessary, quickly replace damaged/missing parts. Assistance is available all day every day. Simply have your store receipt, instruction manual, and part number/description ready when you call our TOLL FREE help line. It's that easy.*

### Servicio al consumidor en que usted puede depender

*¿ Preguntas ? Operadores estan listos en nuestra LINEA DE ASISTENCIA GRATUITA para ayudarle con ensamblaje y si sea necesario reemplazo rápido de partes dañadas o que falten. Asistencia está disponible todo el día todos los días. Simplemente tenga listo su recibo de la tienda, la hoja de instrucciones, y número de parte/descripción cuando llame nuestra LINEA DE ASISTENCIA GRATUITA. Es así de fácil.*

### Vous pouvez compter sur notre service clientèle

*des Questions? Nos opérateurs se tiennent à votre disposition, veuillez contacter notre NUMERO GRATUIT D'ASSISTANCE CLIENTS, où l'on vous portera assistance dans votre assemblage, et si nécessaire, pour le remplacement des pièces défectueuses ou manquantes. Cette assistance est disponible 24/24 et 7/7 jours. Quand vous appelez le NUMERO GRATUIT D'ASSISTANCE CLIENTS, veuillez simplement avoir à portée de main votre ticket d'achat, le manuel d'instructions et les références du modèle. C'est aussi simple que cela.*



## WARNING

Do not load unit without properly attaching back panel. Doing so could cause instability, product collapse, and/or serious injury.

---

No cargue esta unidad sin el panel de atrás. Hacerlo puede causar inestabilidad, que el producto se derrumbe, y/o heridas (golpes) serias.

---

Ne pas charger le produit sans attacher correctement le panneau arrière. Faire ainsi peut causer l'instabilité ou l'effondrement du produit et peut vous causer des endommagements sérieux.



## WARNING

Do not move unit when loaded. Doing so could cause instability, product collapse, tip over, and/or serious injury.

---

No mueva la unidad cuando esté cargada. Hacerlo puede causar inestabilidad, que el producto se derrumbe, que se la caiga encima y/o heridas (golpes) serias.

---

Ne pas déplacer l'unité lorsqu'ell est chargée. Faire ainsi peut causer l'instabilité, l'effondrement ou le renversement du meuble et/ou des endommagements sérieux.

# EXPLODED VIEW

?  
1  
·  
8  
0  
0  
·  
9  
5  
0  
·  
4  
7  
8  
2

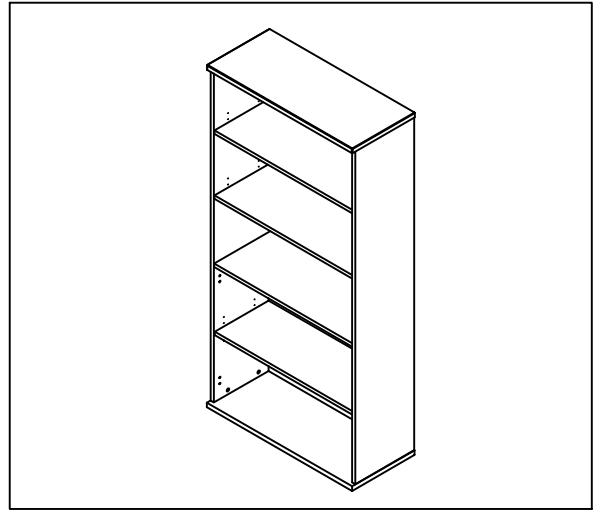
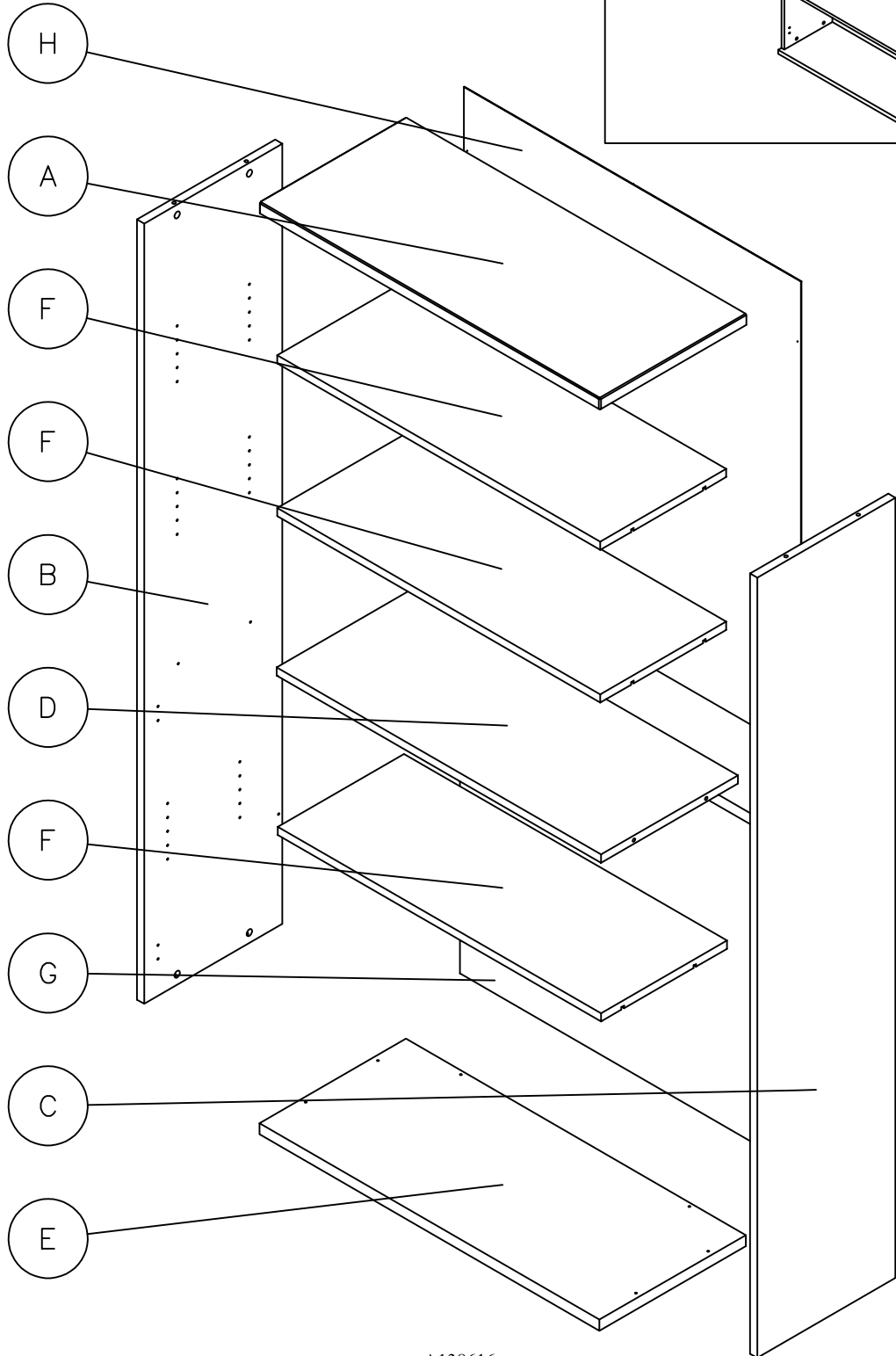

**WC12914**

A	[1]	W128019	E	[1]	W128021
B	[1]	W127993	F	[3]	W128022
C	[1]	W127994	G	[1]	W128023
D	[1]	W128020	H	[1]	W128024

**WC24414**

A	[1]	W96095	E	[1]	W96099
B	[1]	W96096	F	[3]	W96100
C	[1]	W96097	G	[1]	W96101
D	[1]	W96098	H	[1]	W96094

**WC36714**

A	[1]	W128026	E	[1]	W128028
B	[1]	W128002	F	[3]	W128029
C	[1]	W128003	G	[1]	W128030
D	[1]	W128027	H	[1]	W128031

**WC48514**

A	[1]	W93093	E	[1]	W93808
B	[1]	W93804	F	[3]	W93096
C	[1]	W93805	G	[1]	W93097
D	[1]	W93094	H	[1]	W93098

**WC60314**

A	[1]	W128033	E	[1]	W128035
B	[1]	W128011	F	[3]	W128036
C	[1]	W128012	G	[1]	W128037
D	[1]	W128034	H	[1]	W128038

**WC72414**

A	[1]	W96976	E	[1]	W96978
B	[1]	W96968	F	[3]	W96979
C	[1]	W96969	G	[1]	W96980
D	[1]	W96977	H	[1]	W96981

?

1

.

8

0

0

.

9

5

0

.

4

7

8

2

# FASTENER & HARDWARE LIST

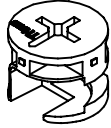

2  
1  
8  
0  
9  
5  
0  
4  
7  
8  
2

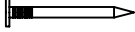

H71659  Quantity **18**

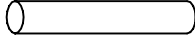

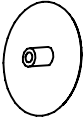
H72988  Quantity **18**

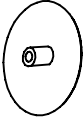

H34174  Quantity **34**  
19mm

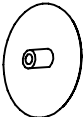

H23604  Quantity **12**

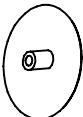

H73621  Quantity <b>12</b>	H63904  Quantity <b>8</b>	<b>WC12914</b>
-------------------------------------------------------------------------------------------------------------	-------------------------------------------------------------------------------------------------------------	----------------

H95137  Quantity <b>12</b>	H96110  Quantity <b>8</b>	<b>WC24414</b>
-------------------------------------------------------------------------------------------------------------	-------------------------------------------------------------------------------------------------------------	----------------

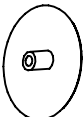
H107306  Quantity <b>12</b>	H107309  Quantity <b>8</b>	<b>WC36714</b>
----------------------------------------------------------------------------------------------------------------	----------------------------------------------------------------------------------------------------------------	----------------

H92520  Quantity <b>12</b>	H92522  Quantity <b>8</b>	<b>WC48514</b>
---------------------------------------------------------------------------------------------------------------	---------------------------------------------------------------------------------------------------------------	----------------

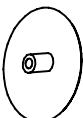
H87676  Quantity <b>12</b>	H100012  Quantity <b>8</b>	<b>WC60314</b>
---------------------------------------------------------------------------------------------------------------	----------------------------------------------------------------------------------------------------------------	----------------

H73620  Quantity <b>12</b>	H96670  Quantity <b>8</b>	<b>WC72414</b>
---------------------------------------------------------------------------------------------------------------	---------------------------------------------------------------------------------------------------------------	----------------

H72988

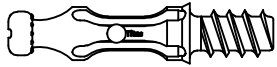

[ 8 ]

H63904 Quantity 8 **WC12914**

H92522 Quantity 8 **WC48514**

H96110 Quantity 8 **WC24414**

H100012 Quantity 8 **WC60314**

H107309 Quantity 8 **WC36714**

H96670 Quantity 8 **WC72414**

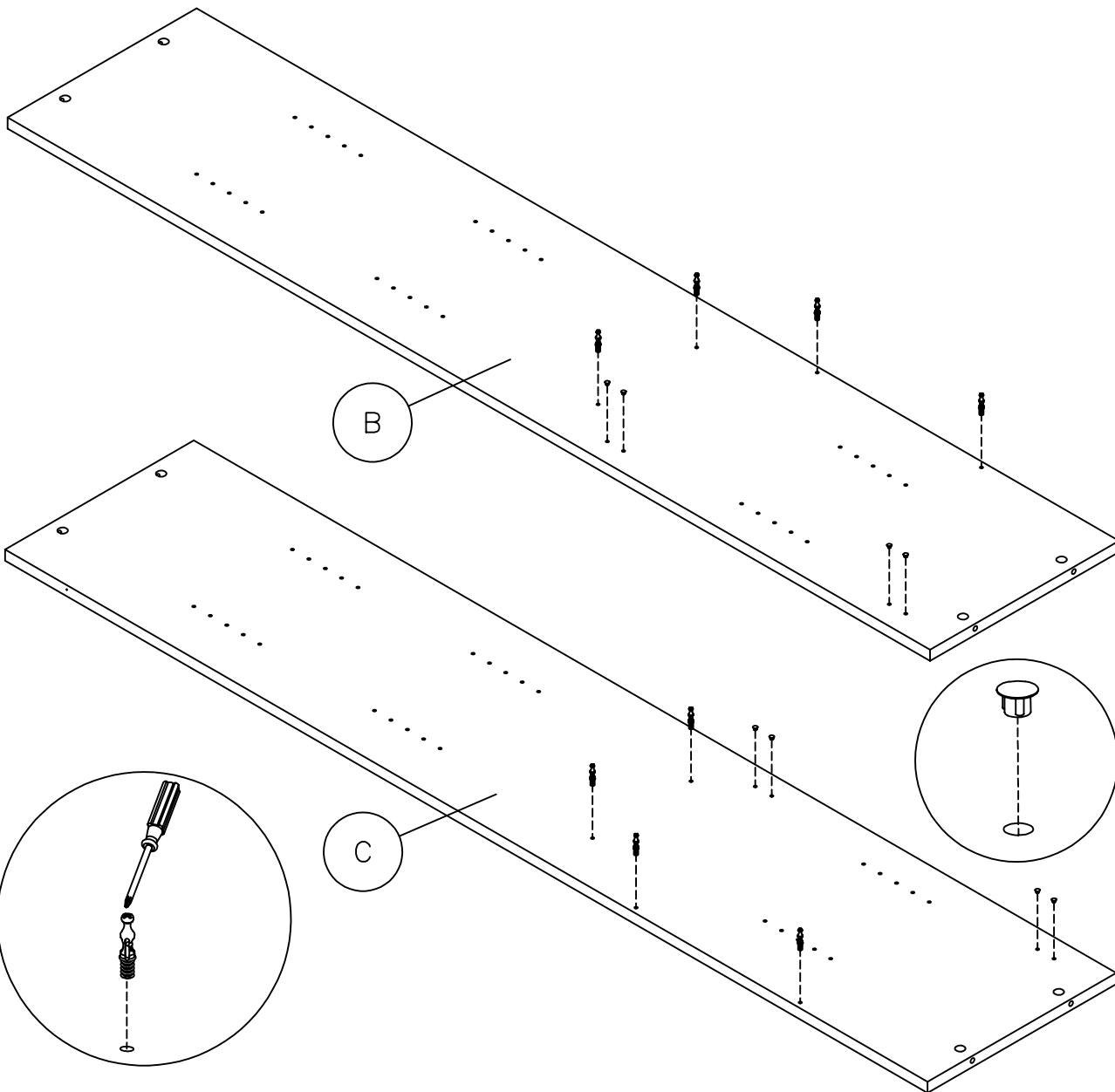

1

?  
1  
·  
8  
0  
0  
·  
9  
5  
0  
·  
4  
7  
8  
2

A138616



2

H71659

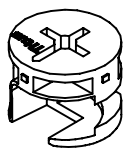

[ 4 ]

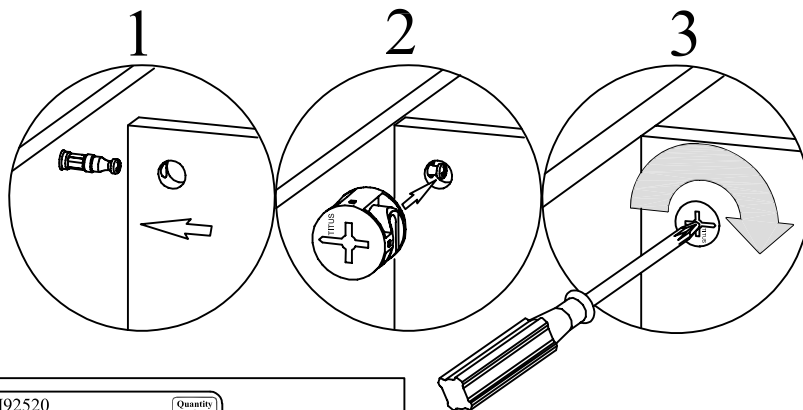

H73621	Quantity 2	<b>WC12914</b>
--------	---------------	----------------

H92520	Quantity 2	<b>WC48514</b>
--------	---------------	----------------

H95137	Quantity 2	<b>WC24414</b>
--------	---------------	----------------

H87676	Quantity 2	<b>WC60314</b>
--------	---------------	----------------

H107306	Quantity 2	<b>WC36714</b>
---------	---------------	----------------

H73620	Quantity 2	<b>WC72414</b>
--------	---------------	----------------

?

1  
·  
8  
0  
0  
·  
9  
5  
0  
·  
4  
7  
8  
2

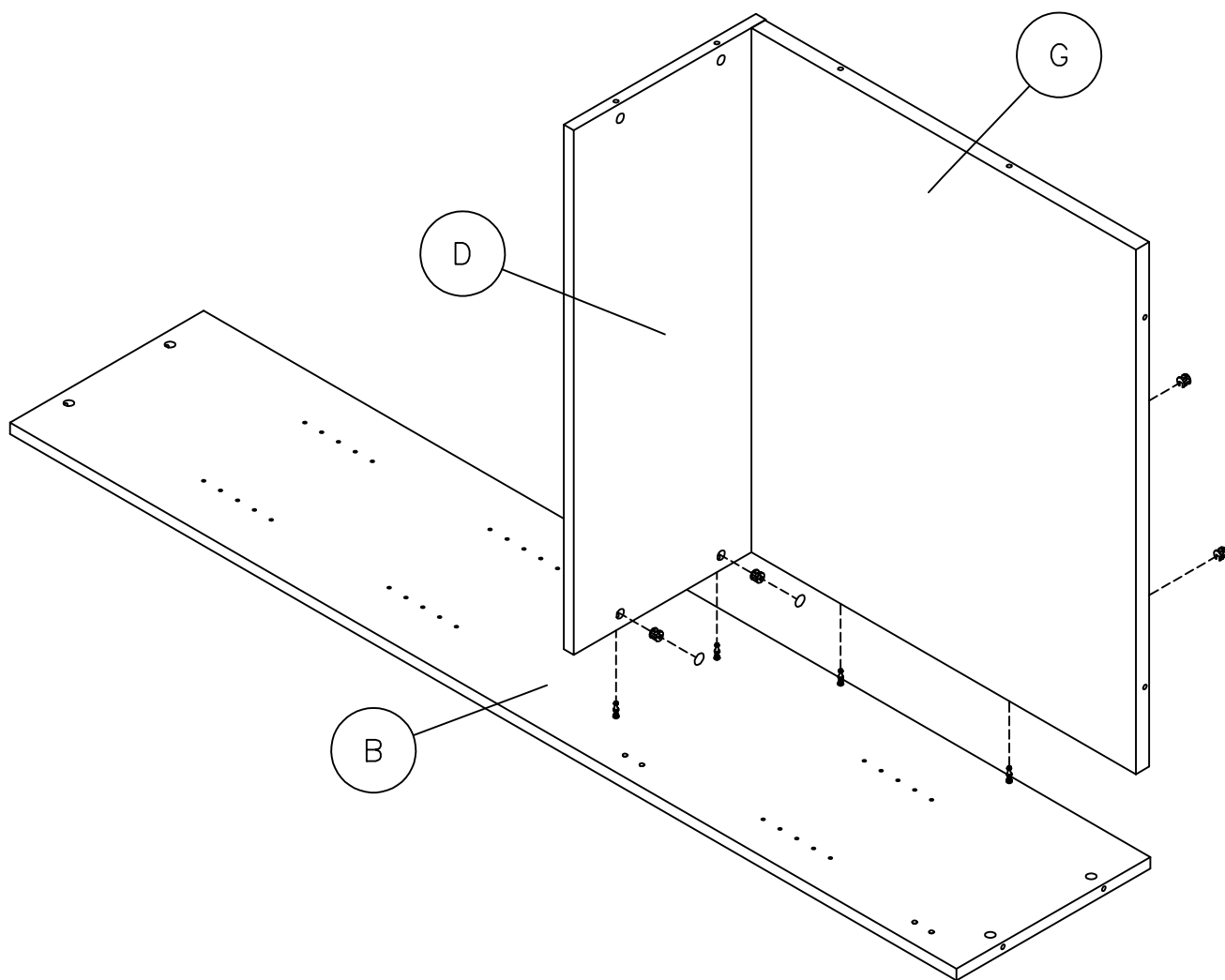

H71659

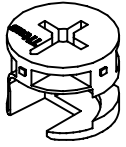

[ 4 ]

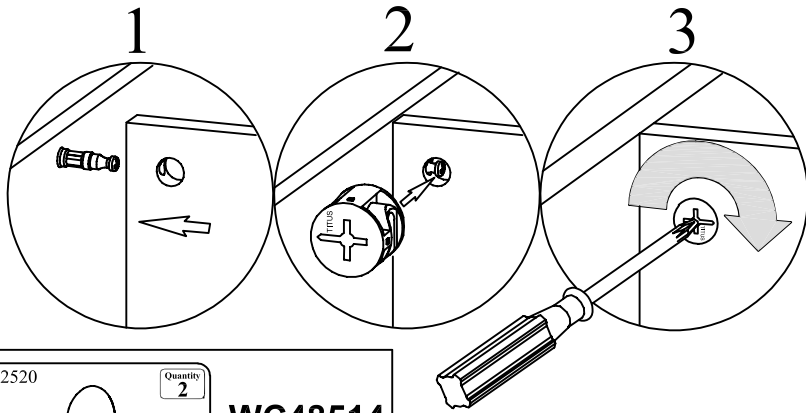

H73621 Quantity 2 **WC12914**

H95137 Quantity 2 **WC24414**

H107306 Quantity 2 **WC36714**

H92520 Quantity 2 **WC48514**

H87676 Quantity 2 **WC60314**

H73620 Quantity 2 **WC72414**

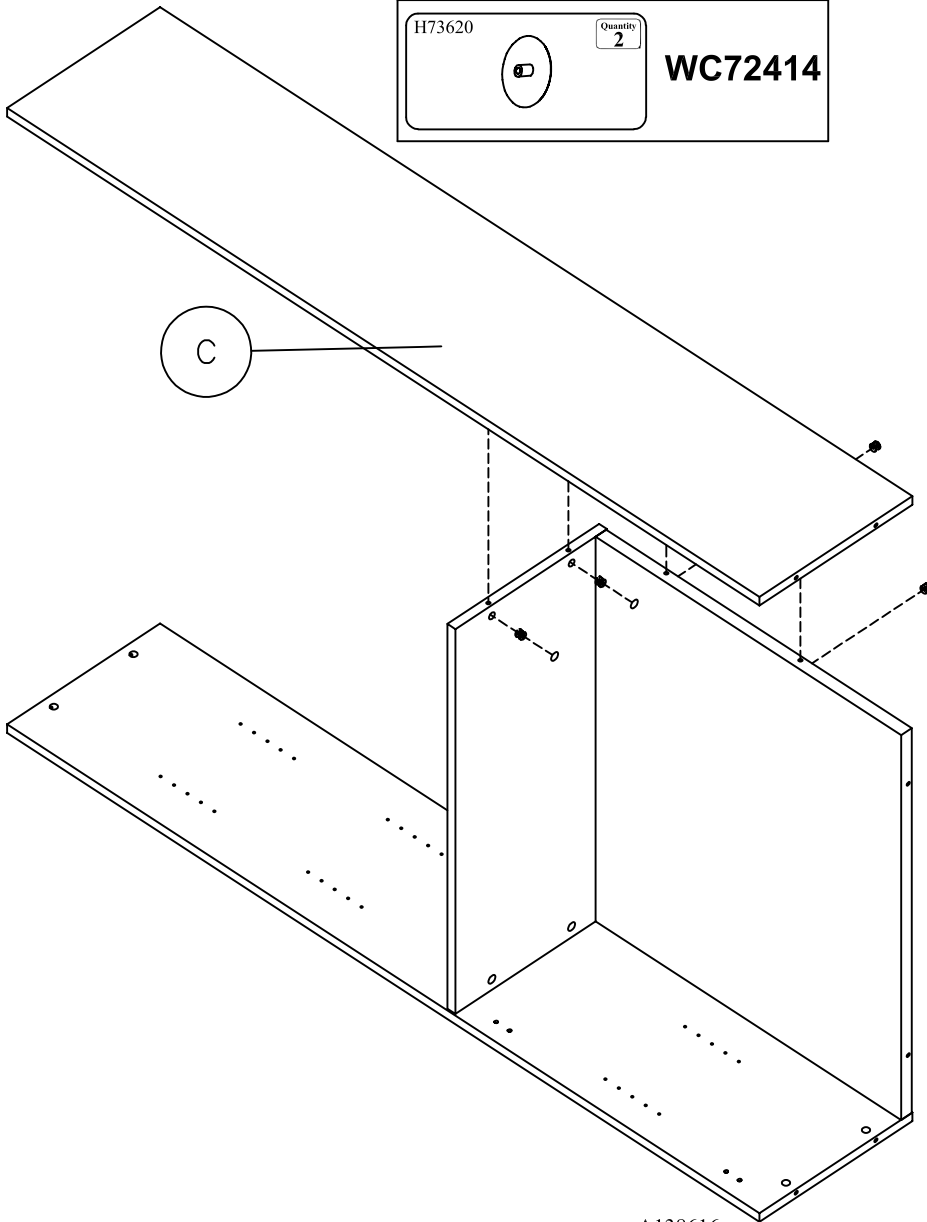

3

?  
1  
·  
8  
0  
0  
·  
9  
5  
0  
·  
4  
7  
8  
2

A138616

4

H72988

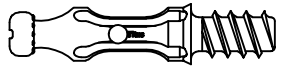

[ 10 ]

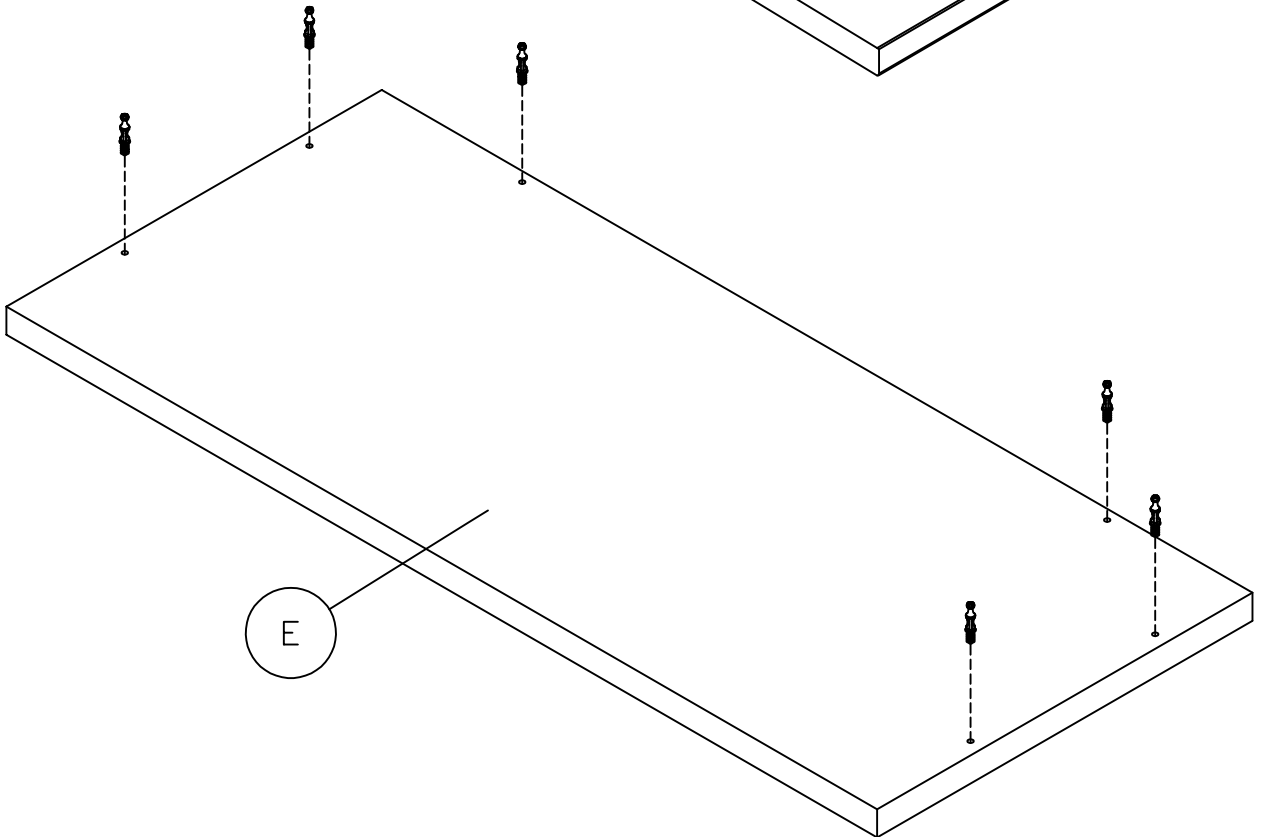
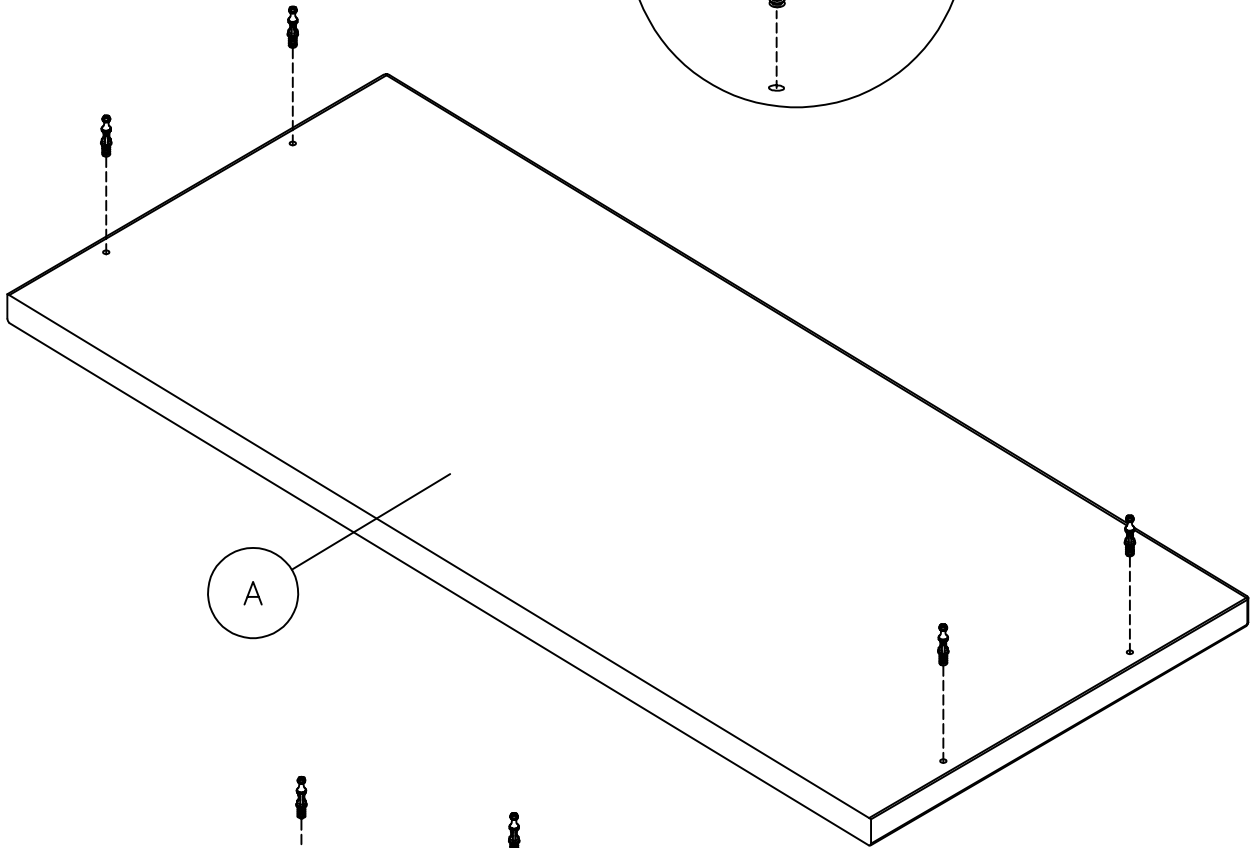
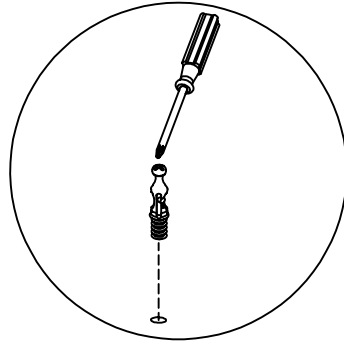

?

1  
·  
8  
0  
0  
·  
9  
5  
0  
·  
4  
7  
8  
2

H71659

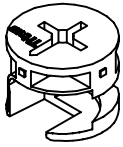

[ 4 ]

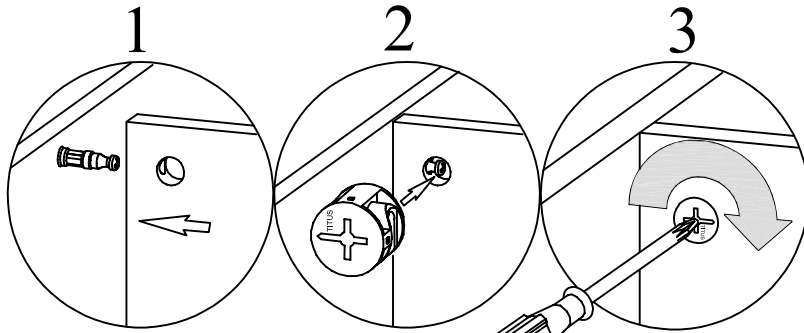

H73621	Quantity 4	<b>WC12914</b>
--------	------------	----------------

H95137	Quantity 4	<b>WC24414</b>
--------	------------	----------------

H107306	Quantity 4	<b>WC36714</b>
---------	------------	----------------

H92520	Quantity 4	<b>WC48514</b>
--------	------------	----------------

H87676	Quantity 4	<b>WC60314</b>
--------	------------	----------------

H73620	Quantity 4	<b>WC72414</b>
--------	------------	----------------

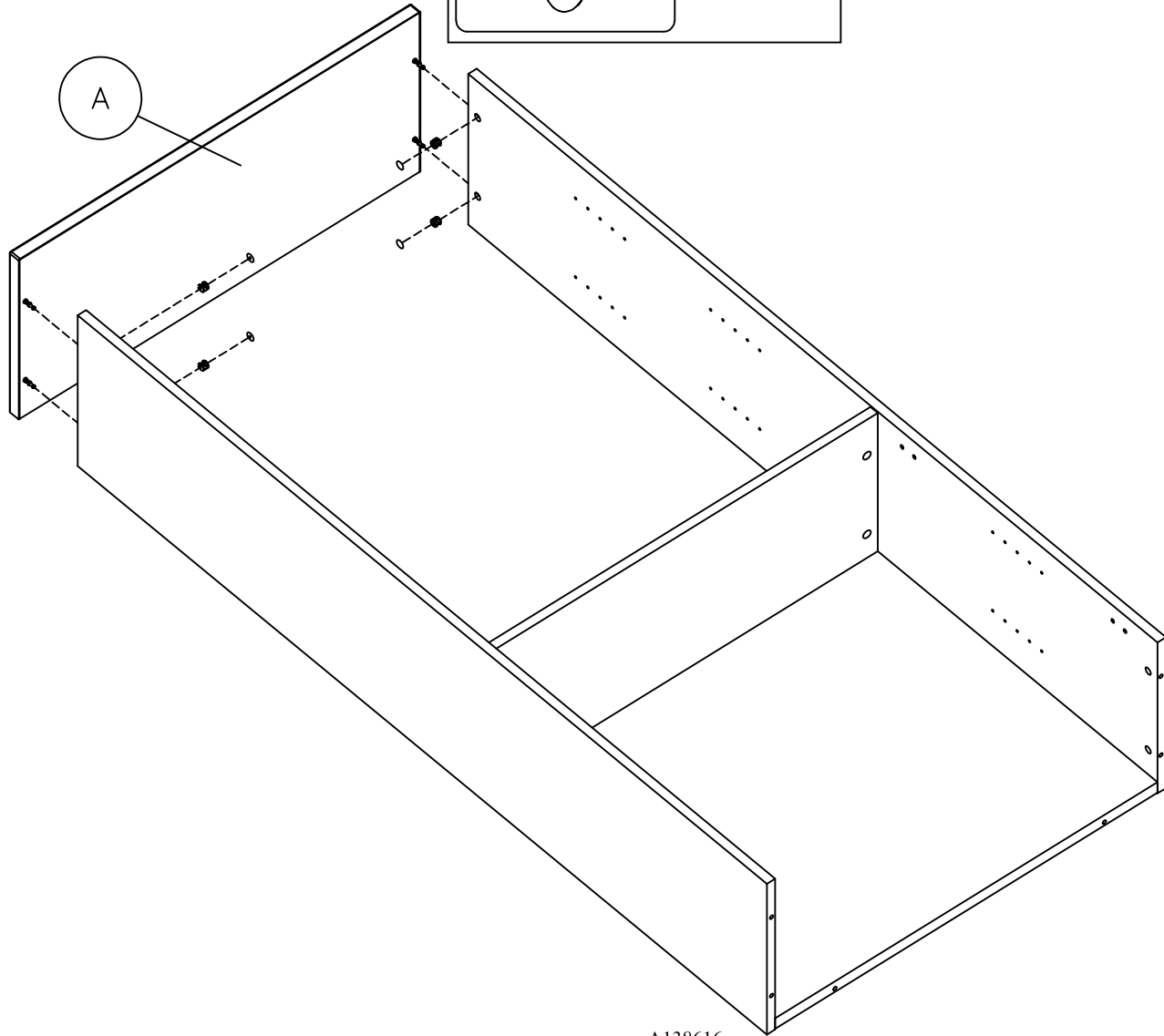

A138616

5

?  
1  
·  
8  
0  
0  
·  
9  
5  
0  
·  
4  
7  
8  
2

6

H71659

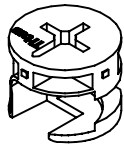

[ 6 ]

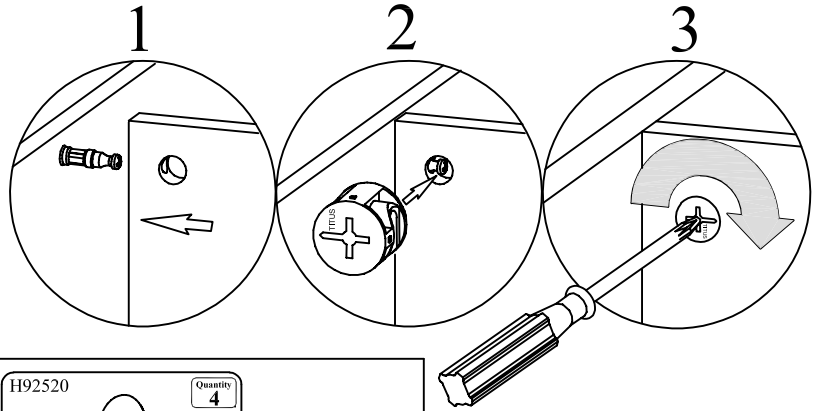

H73621	Quantity 4		<b>WC12914</b>
--------	------------	--	----------------

H92520	Quantity 4		<b>WC48514</b>
--------	------------	--	----------------

H95137	Quantity 4		<b>WC24414</b>
--------	------------	--	----------------

H87676	Quantity 4		<b>WC60314</b>
--------	------------	--	----------------

H107306	Quantity 4		<b>WC36714</b>
---------	------------	--	----------------

H73620	Quantity 4		<b>WC72414</b>
--------	------------	--	----------------

?

1  
·  
8  
0  
0  
·  
9  
5  
0  
·  
4  
7  
8  
2

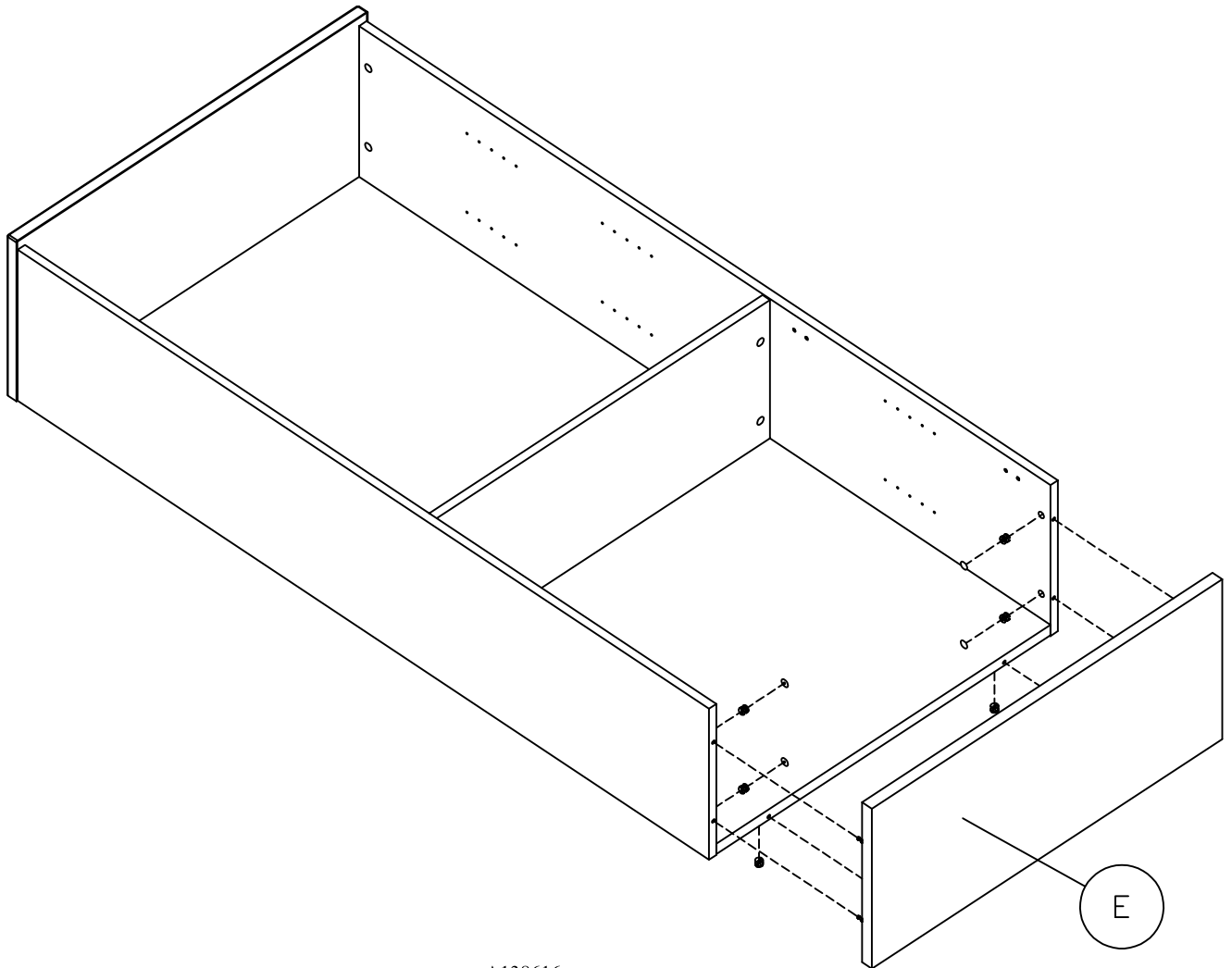

Positioning Holes  
 Hoyos de Posicion  
 Positioner les Trous

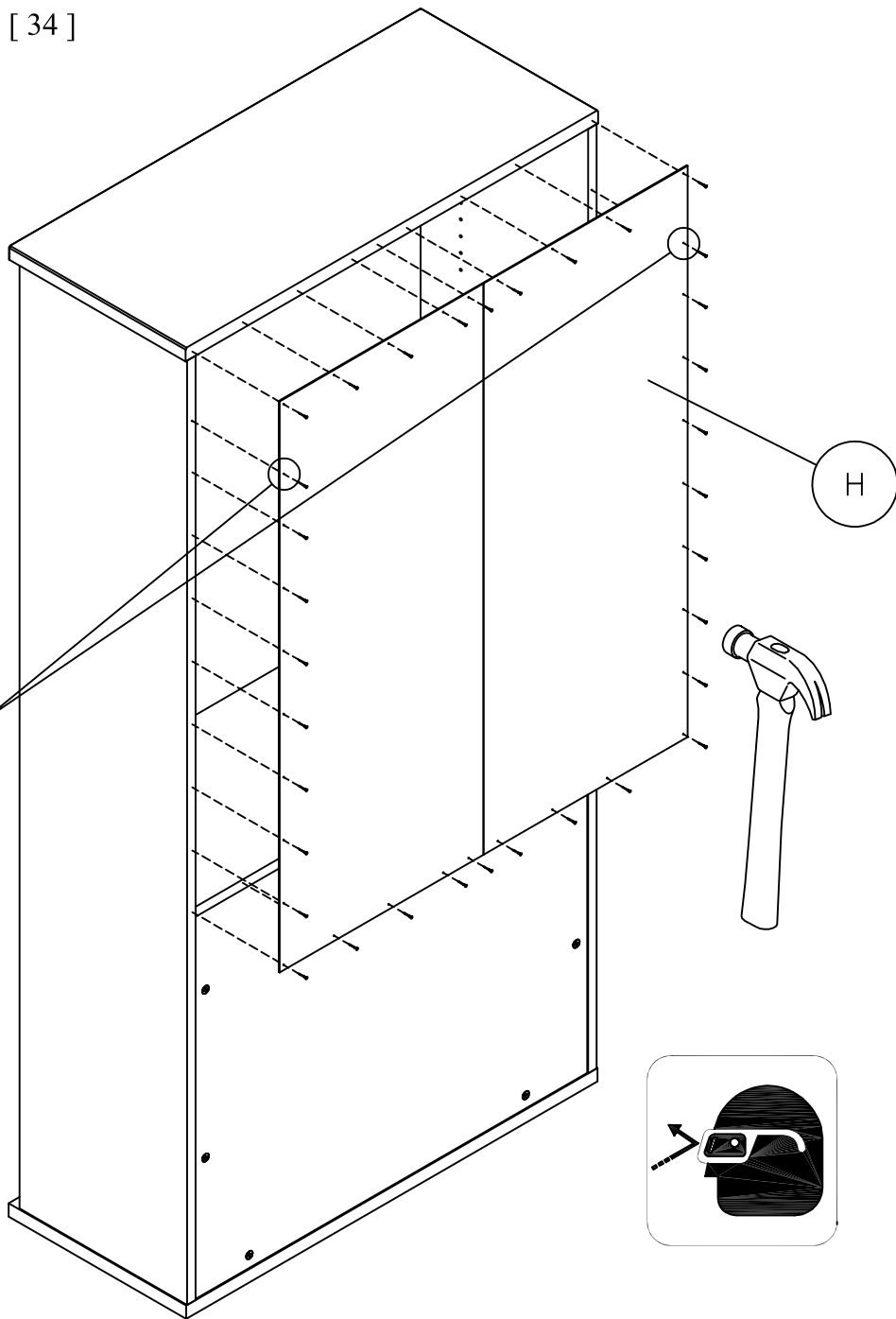

 <b>WARNING</b>		
Do not load unit without properly attaching back panel. Doing so could cause instability, product collapse and/or serious injury.	No cargue esta unidad sin el panel de atrás. Hacerlo puede causar inestabilidad, que el producto se derrumbe, y/o heridas (golpes) serias.	Ne pas charger le produit sans attacher correctement le panneau arrière. Faire ainsi peut causer l'instabilité ou l'effondrement du produit et peut vous causer des endommagements sérieux.

H23604 [ 12 ]

Maximum Weight: 0 Lbs.  
Peso Máximo: 0 Libras  
Poids Maximum: 0 kilogramme

Maximum Weight: 50 Lbs.  
Peso Máximo: 50 Libras  
Poids Maximum: 22.7 kilogramme

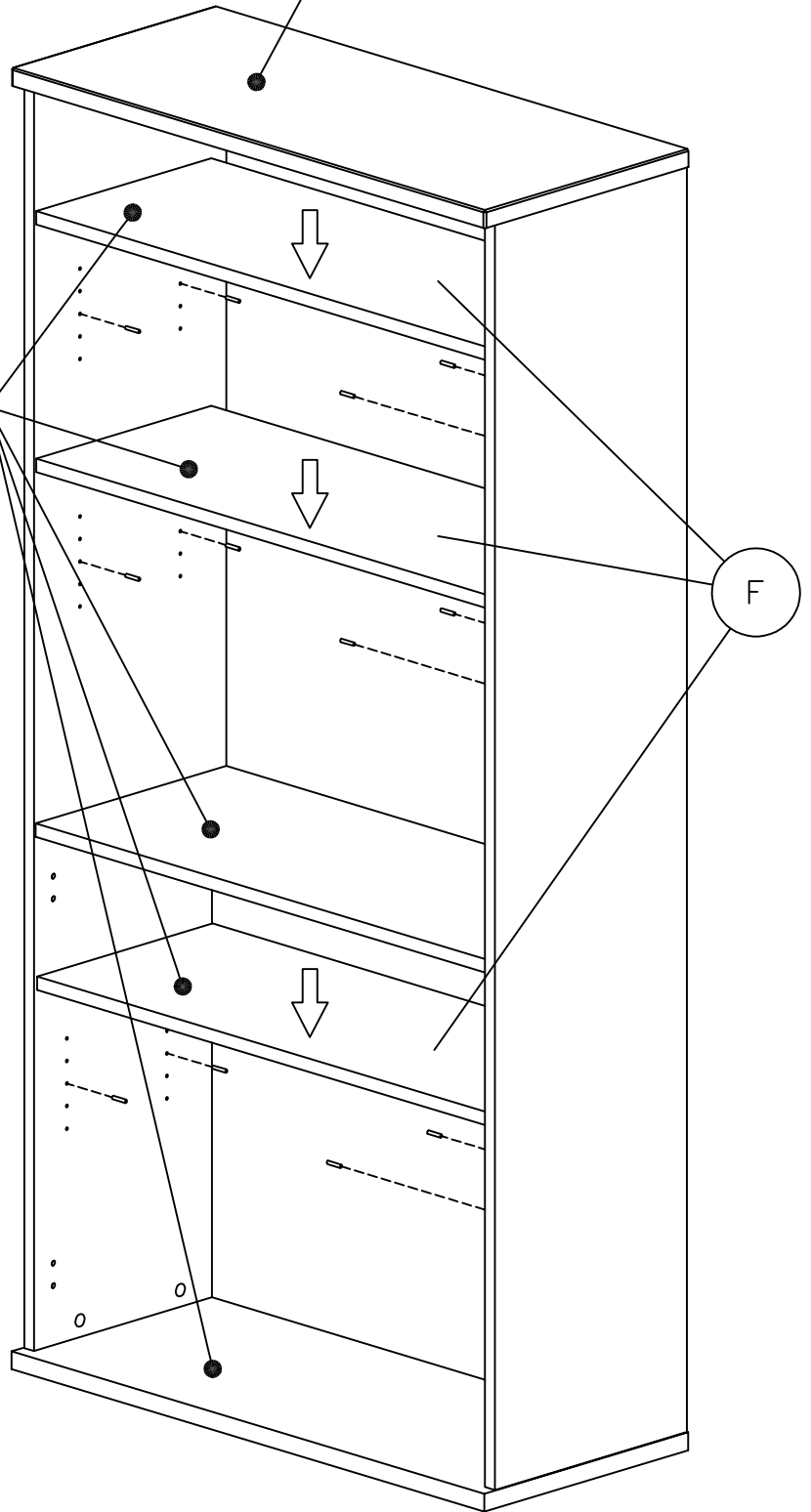

?

1  
·  
8  
0  
0  
·  
9  
5  
0  
·  
4  
7  
8  
2