

**MODEL 6399CS
6399MC**



Can we help you?

THE BUSH BUSINESS FURNITURE

difference

- QUALITY
- INNOVATION
- SERVICE
- VALUE

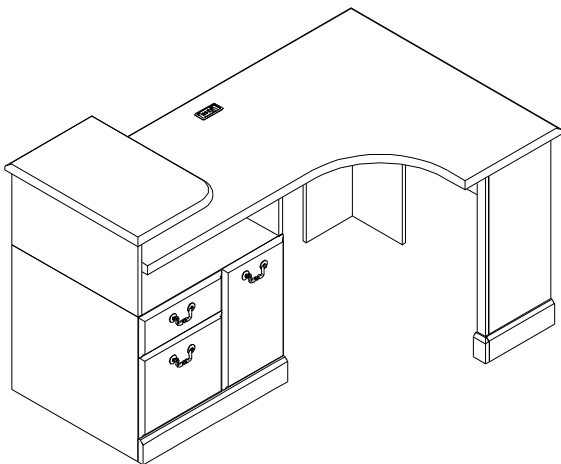

A159906

Bush[®]
BUSINESS FURNITURE

Thank you for purchasing this Bush Business Furniture product. We trust that you will be completely satisfied with your product for many years to come. Bush Business Furniture products are backed by a 10-year warranty and crafted with today's styles in mind for the way you live. **Do not return product to store, contact us first at 1-800-950-4782.**

Merci d'avoir acheté ce produit Bush Business Furniture. Nous sommes sûr que vous serez complètement satisfait de votre meuble pendant de nombreuses années. Les produits Bush Business Furniture sont garantis pendant 10 ans et sont conçus dans les styles actuels tout en gardant à l'esprit votre façon de travailler. **Ne renvoyez pas le produit au magasin, contactez-nous d'abord au 1-800-950-4782.**

Gracias por comprar este producto de Bush Business Furniture. Confiamos que usted estará completamente satisfecho con su mueble por muchos años. Los productos de Bush Business Furniture tienen 10 años de garantía y son diseñados con los estilos de hoy en mente para la manera que usted vive. **No devuelva el producto a la tienda, primero comuníquese con nosotros al 1-800-950-4782.**

10 Year
COMMERCIAL
WARRANTY



M - F 8:30 a.m. - 7:30 p.m.

Sat. 9:00 a.m. - 5:30 p.m.

(Except Holidays)

Consumer Service Department

P.O. Box 460
One Mason Dr.

Jamestown, NY 14702

ConsumerService@BushIndustries.com

1-800-950-4782 USA/CANADA

001-800-950-4782 MEXICO

Se habla español



www.bushbusinessfurniture.com

IT'S AS EASY AS 1,2,3

Assembly tips:

1. Read the instructions and become familiar with the parts.
2. Ensure this carton contains all parts, fasteners and hardware.
3. To protect floors, assemble the furniture on the carton.
4. An assistant may be helpful.
5. Use of power tools is not recommended.

Conseils d'assemblage:

1. Lisez les instructions et familiarisez-vous avec les pièces.
2. Assurez-vous que le carton contient toutes les pièces, toutes les pièces de fixation et toute la quincaillerie.
3. Pour protéger vos sols, assemblez le meuble sur le carton.
4. Il peut être utile de vous faire aider.
5. L'utilisation d'outils électriques n'est pas recommandée.

Consejos de Ensamblaje:

1. Lea las instrucciones y familiarícese con las partes.
2. Asegúrese de que esta caja contenga todas las piezas, los sujetadores y el equipo.
3. Para proteger el piso, ensamble el mueble en el carton.
4. Un asistente puede serle útil.
5. El uso de herramientas eléctricas no se recomienda.

CONSUMER SERVICE YOU CAN DEPEND ON

Questions? Operators are standing by at our TOLL-FREE help line to assist you with assembly; and, if necessary, to quickly replace damaged/missing parts. Assistance is available 6 days a week. Simply have your store receipt, instruction manual, and part number/description ready when you call our TOLL -FREE help line. It's that easy.

UN SERVICE CLIENTELE SUR LEQUEL VOUS POUVEZ COMPTER

Des questions? Des opérateurs sont prêts sur notre ligne d'assistance GRATUITE pour vous aider à l'assemblage et, si nécessaire, remplacer rapidement les pièces endommagées/manquantes. L'assistance est disponible 6 jours par semaine. Ayez simplement votre reçu de magasin, votre manuel d'instruction et le numéro de pièces/description à votre disposition lorsque vous appelez notre ligne d'assistance GRATUITE. C'est aussi simple que ça.

SERVICIO AL CONSUMIDOR CON EL QUE PUEDE CONTAR

¿Preguntas? Los operadores están listos para ayudarlo con el ensamblaje a través de una línea de ayuda GRATUITA, y en caso de ser necesario, reemplazar de inmediato las piezas dañadas o faltantes. La asistencia está disponible los 6 días de la semana. Solamente tenga listos su recibo de compra, manual de indicaciones y número/descripción de la pieza al momento de llamarnos a la línea de ayuda GRATUITA, Es así de sencillo.

IMPORTANT SAFETY INFORMATION



WARNING

This product is designed and intended for use with computer, fax, and printer equipment only. Improper loading with television or other heavy equipment could cause instability, tip over, and/or serious injury.

Este producto esta diseñado solamente para el uso con computadores, faxes, e impresoras. Inapropiado uso al poner televisores u otro equipo pesado puede causar inestabilidad, rodamiento, y/o herida (golpes) serios.

Ce produit est uniquement conçu pour une utilisation avec un ordinateur, un télécopieur, ou une imprimante. Un chargement incorrect avec une télévision ou autre matériel lourd peut le rendre instable ou le renverser, et peut vous causer des endommagements sérieux.



WARNING

Do not move unit when loaded. Doing so could cause instability, product collapse, tip over, and/or serious injury.

No mueva la unidad cuando esté cargada. Hacerlo puede causar inestabilidad, que el producto se derrumbe, que se la caiga encima y/o heridas (golpes) serias.

Ne pas déplacer l'unité lorsqu'ell est chargée. Faire ainsi peut causer l'instabilité, l'effondrement ou le renversement du meuble et/ou des endommagements sérieux.

IMPORTANT SAFETY INFORMATION

NOTICE

This compartment is intended to hold computer equipment. The door must be kept open when equipment is operated. Failure to do so could restrict airflow and may result in equipment overheating.

El compartimiento está diseñado para acomodar un computador. La puerta debe mantenerse abierta mientras el equipo es operado. El no mantener la puerta abierta durante la operación puede restringir el flujo de aire y resultar en el computador calentarse demasiado.

Ce compartiment est prévu pour tenir le matériel informatique. La porte doit être maintenue ouverte tandis que le matériel est utilisé. Le manque de faire ainsi a pu limiter la circulation d'air et peut avoir comme conséquence la surchauffe du matériel.

EXPLODED VIEW

6399CS

A	[1]	S160400
B	[1]	S160401
C	[1]	S160402
D	[1]	S160403
E	[1]	S160404
F	[1]	S160405
G	[1]	S158370
H	[1]	S158371
I	[1]	S158372
J	[1]	S158373
K	[1]	S158374
L	[1]	S159907
M	[1]	S158376
N	[1]	S159908
O	[1]	S158378
P	[1]	S158989
Q	[1]	S159909

6399MC

A	[1]	S158379
B	[1]	S158380
C	[1]	S158381
D	[1]	S158382
E	[1]	S158383
F	[1]	S158384
G	[1]	S158385
H	[1]	S158386
I	[1]	S158387
J	[1]	S158388
K	[1]	S158389
L	[1]	S159910
M	[1]	S158460
N	[1]	S159911
O	[1]	S158507
P	[1]	S158990
Q	[1]	S159912

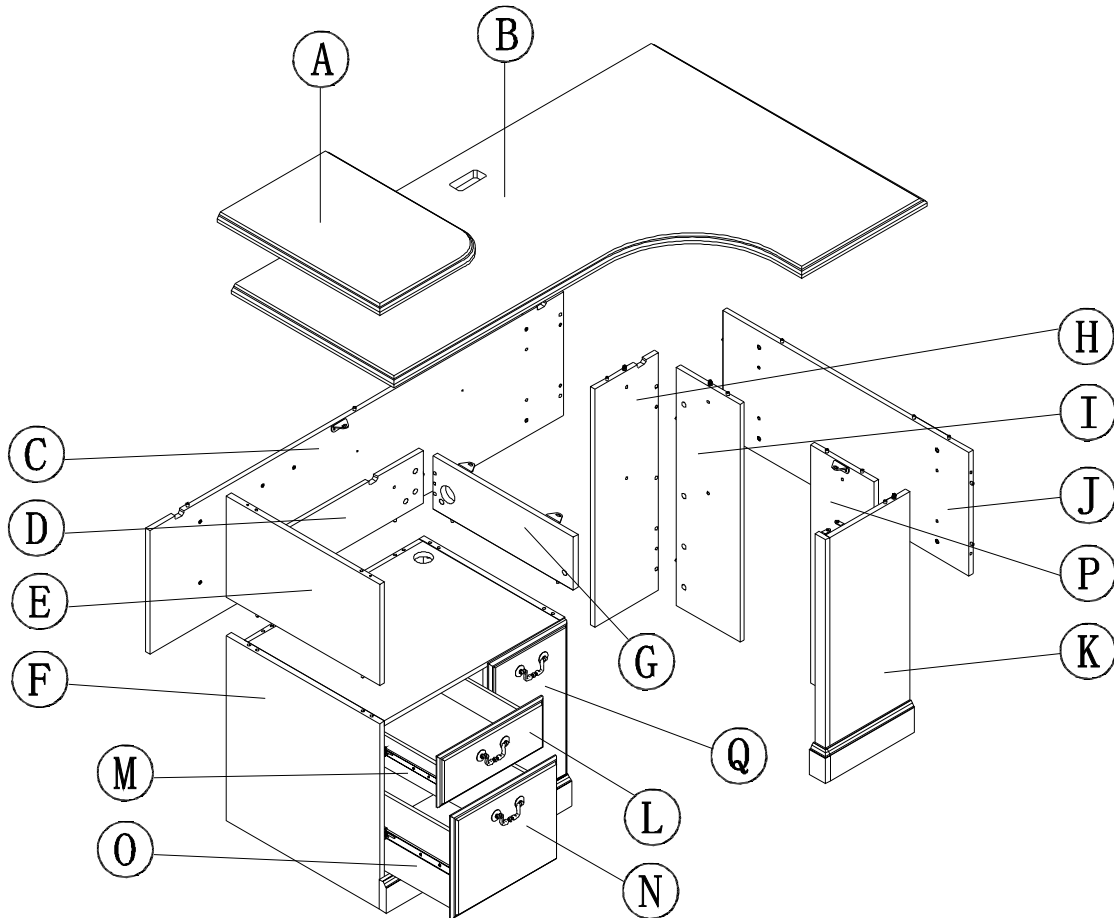
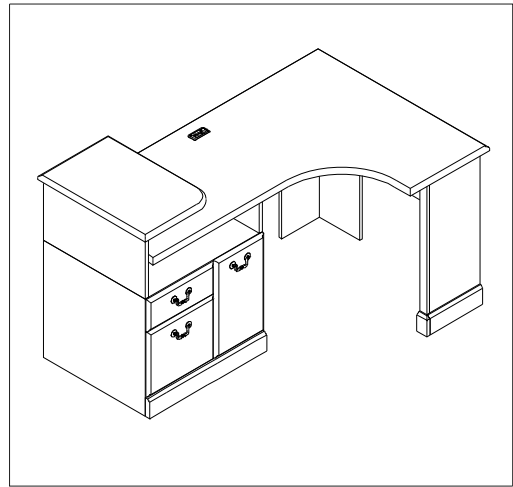

? 1 - 800 - 950 - 4782

A159906

FASTENER LIST

H157569 Quantity 2

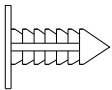

#4 x 1/2"

H158135 Quantity 12



H158136 Quantity 24

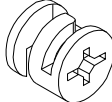

H158138 Quantity 6

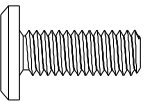

M6 x 16

H158139 Quantity 8

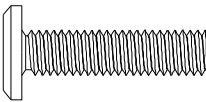

M6 x 25

H158989 Quantity 4

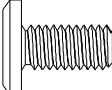

M6 x 12

H157929 Quantity 6

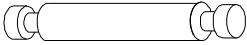

H67187 Quantity 1

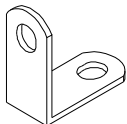

H157928 Quantity 2

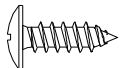

#8 x 1/2"

H158990 Quantity 6



M8x20mm

PRE-ASSEMBLED COMPONENTS

H158137

Quantity
3

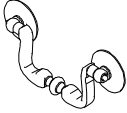

6399CS

H157920

Quantity
3

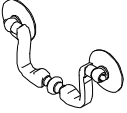

6399MC

H157927

Quantity
6

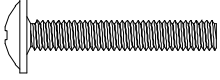

M4x25mm

H67187

Quantity
2

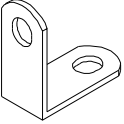

H158506

Quantity
10

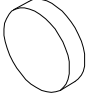

HARDWARE LIST

H157573

Quantity
2

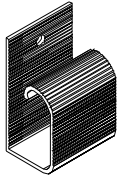

H157902

Quantity
1

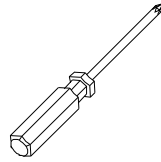

H157876

Quantity
2

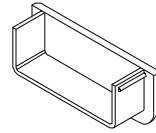

H158141

Quantity
4



H158142

Quantity
1



H158991

Quantity
1

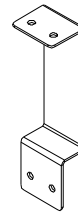

H158143

Quantity
6

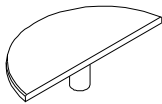

6399CS

H158357

Quantity
6

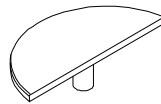

6399MC

H157939

Quantity
24

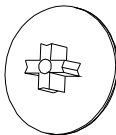

6399CS

H158358

Quantity
24

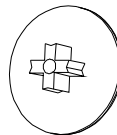

6399MC

HARDWARE

H157520

Quantity

1

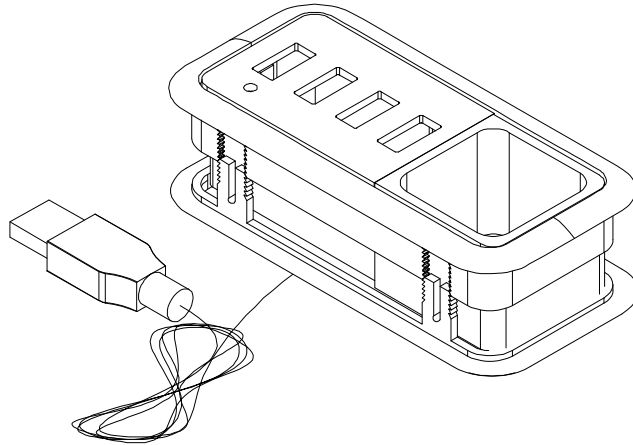

This device complies with part 15 of the FCC Rules. Operation is subject to the following two conditions: (1) This device may not cause harmful interference, and (2) this device must accept any interference received, including interference that may cause undesired operation.

Este aparato acata las regulaciones establecidas en la Sección 15 del FCC (Federal Communications Commission). La operación está sujeta a las dos siguientes condiciones: (1) este aparato no causa interferencia nociva, y (2) este aparato acepta cualquier interferencia recibida, incluyendo interferencia que pueda causar una operación no deseable.

Ce dispositif est conforme à la partie 15 des règles de FCC. L'opération est sujette aux deux conditions suivantes : (1) ce dispositif ne peut pas causer l'interférence nocive, et (2) ce dispositif doit accepter n'importe quelle interférence reçue, y compris l'interférence qui peut causer l'opération peu désirée.

STEP 1

Common assembly techniques.
Técnica común de ensamblaje.
Techniques communes d'assemblage.

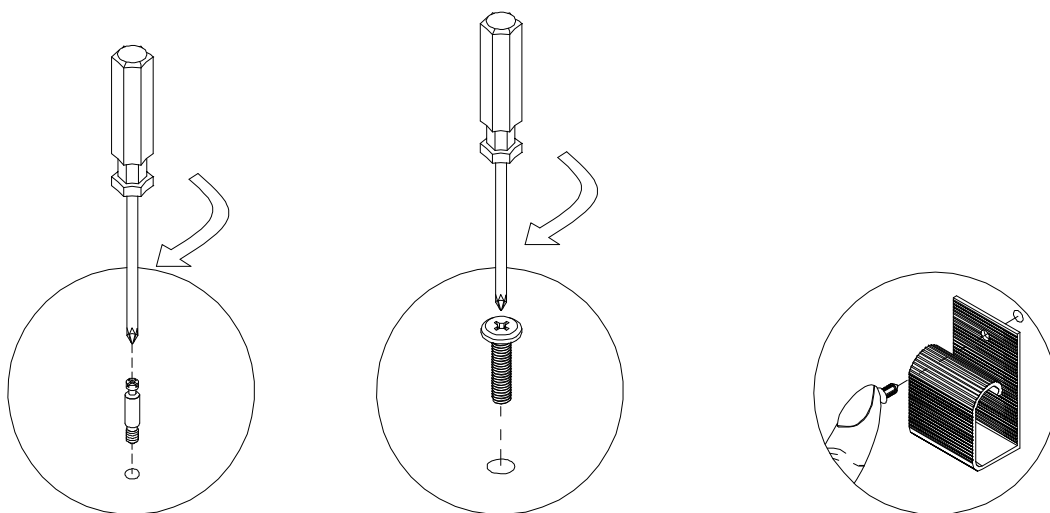
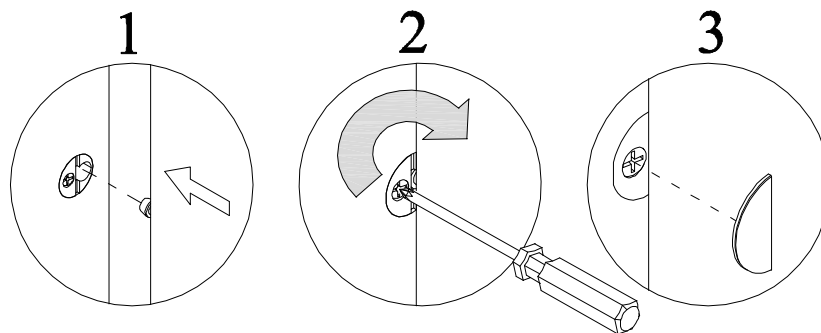
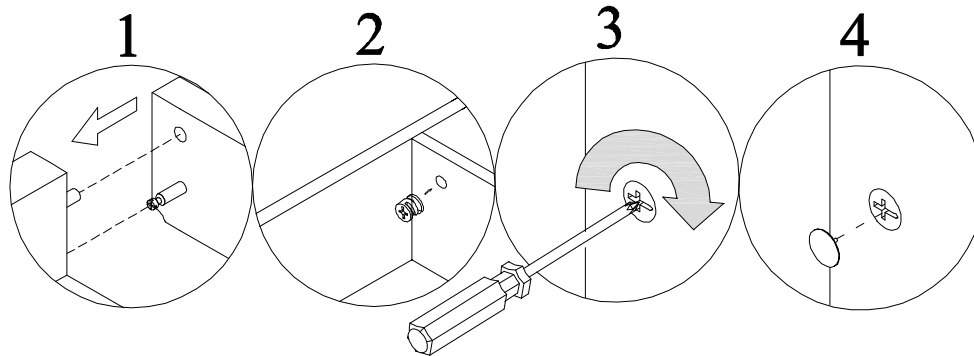

? 1 - 800 - 950 - 4782

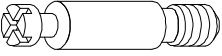

A159906

STEP 2

H158135  [2]

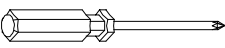
H158136  [2]

H157902 

H157939  [2]	6399CS
H158358  [2]	6399MC

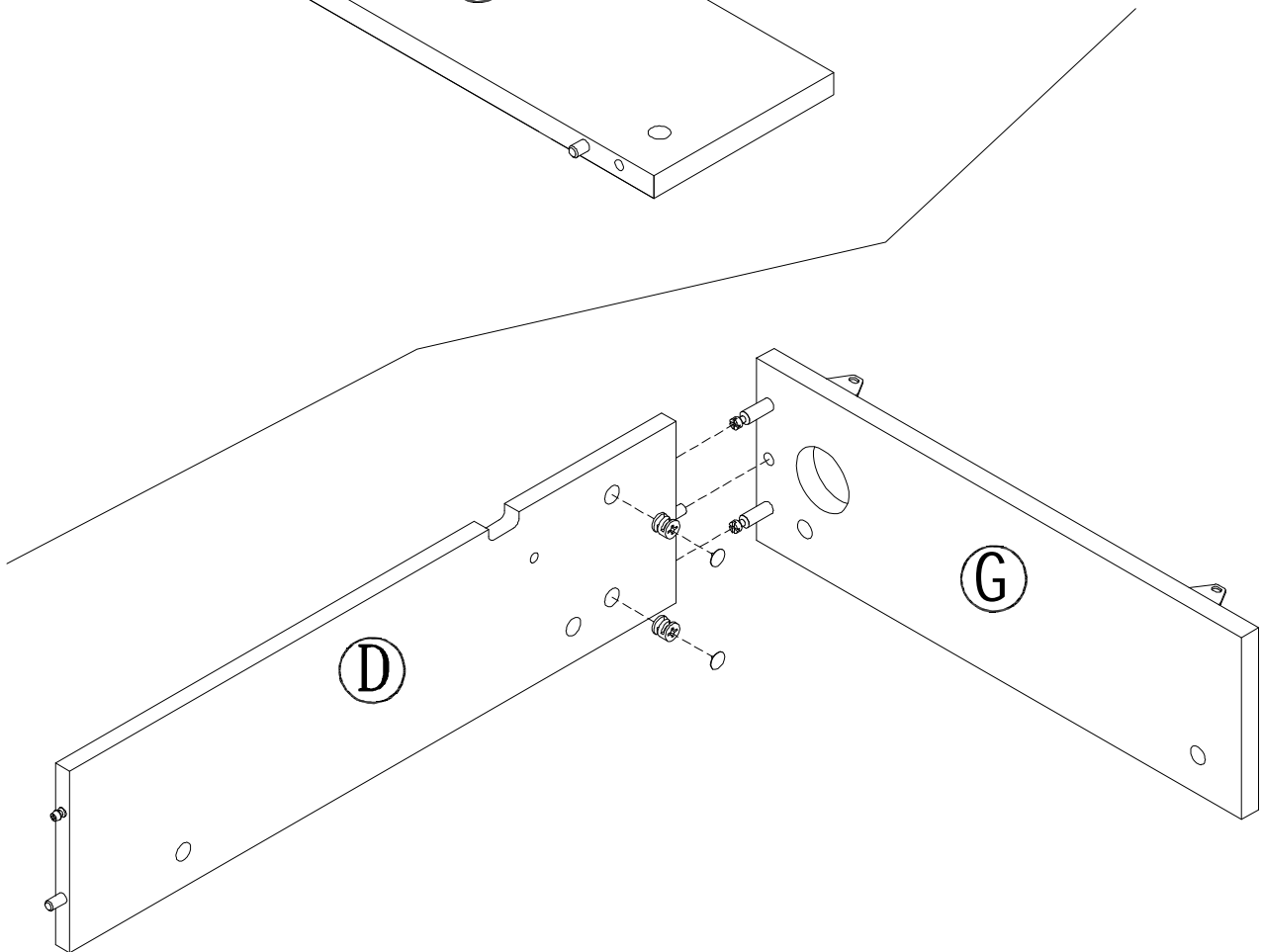
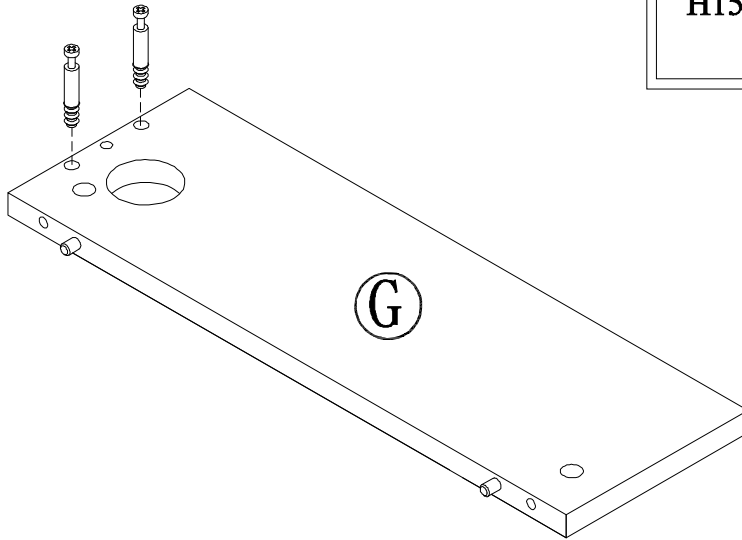

? 1 - 800 - 950 - 4782

A159906

STEP 3

H158141 [1]



H157902

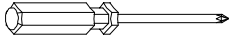

H158143

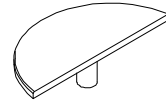

[1]

6399CS

H158357

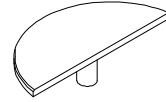

[1]

6399MC

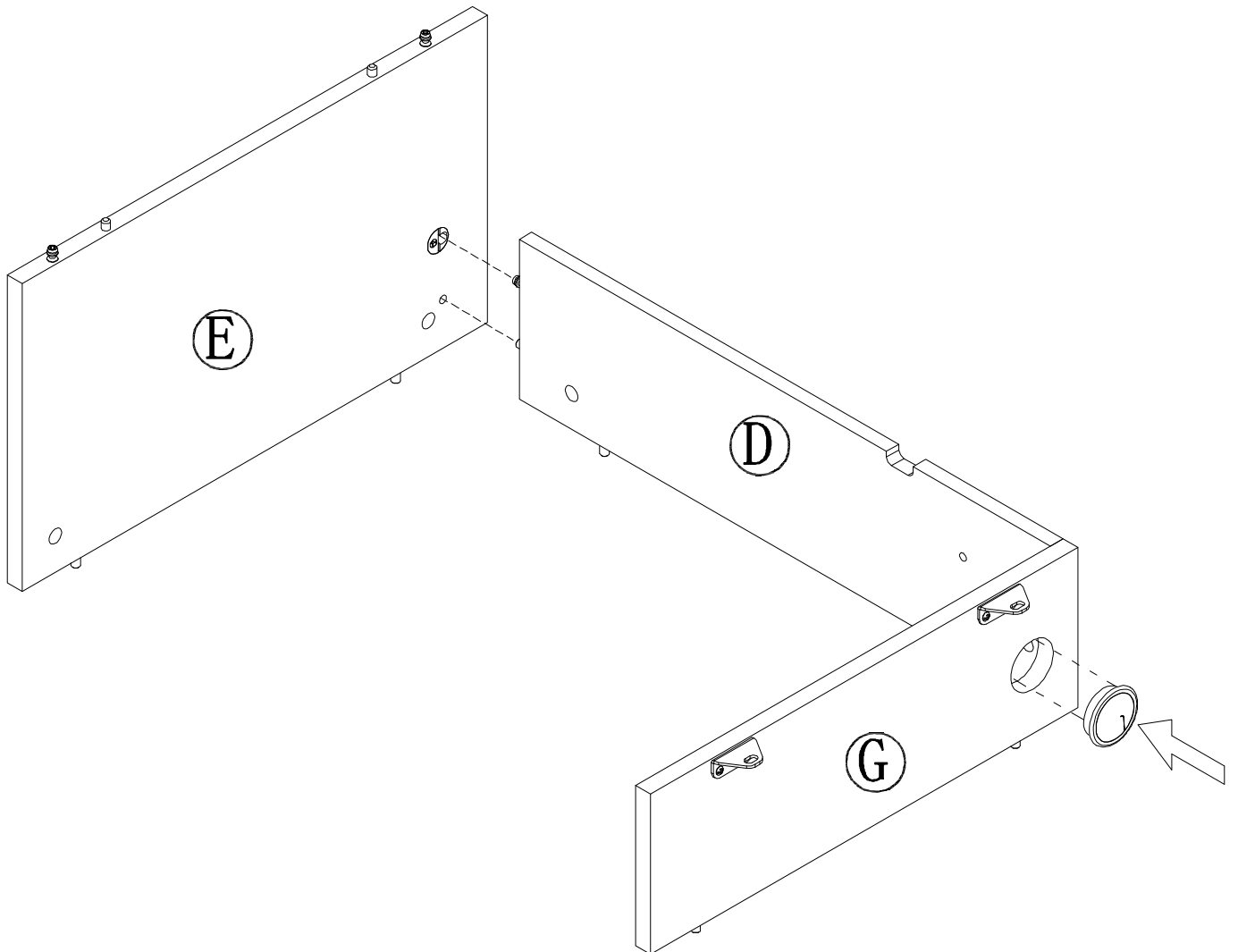

? 1 - 800 - 950 - 4782

A159906

STEP 4

H158141



[3]

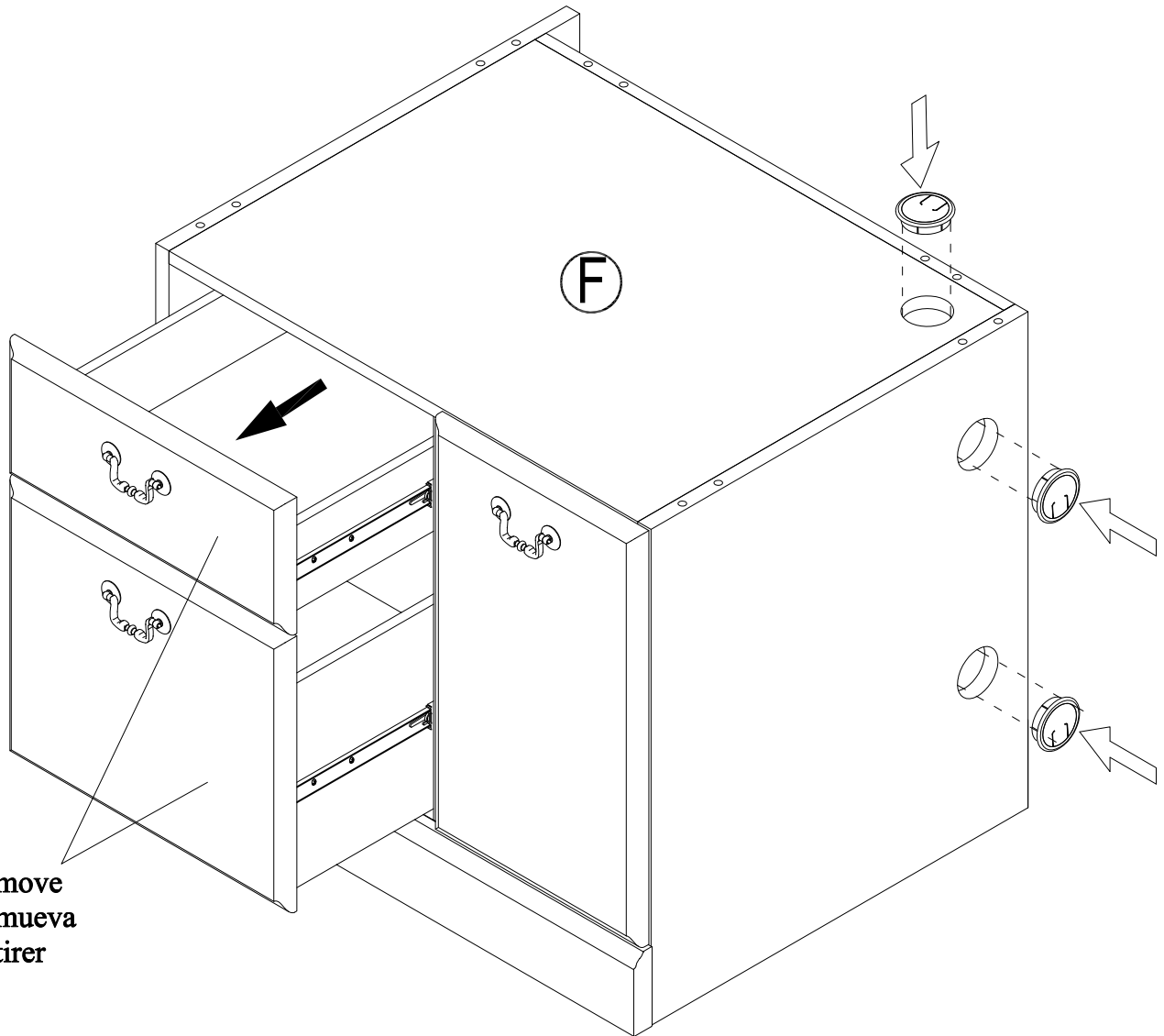

Remove
Remueva
Retirer

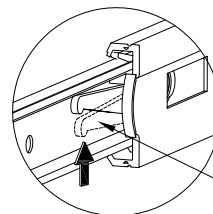

Lock Lever
Palanca de Cerradura
Levier d'arrêt

Move lock lever on the drawer runner as shown and separate drawer runner from drawer slide.
Mueva Palanca de la Cerradura en la corredera como se muestra y separe la corredera del deslizable.
Relever le Levier d'arrêt sur la coulisse pour tiror et séparez le coulisseau de la coulisse tel que montré.

? 1 - 800 - 950 - 4782

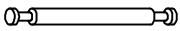

A159906

STEP 5

H157929  [6]

H158136  [6]

H157902 

H157939 	[6]	6399CS
H158358 	[6]	6399MC

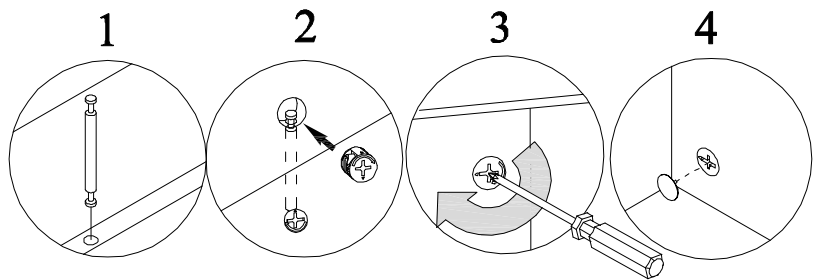
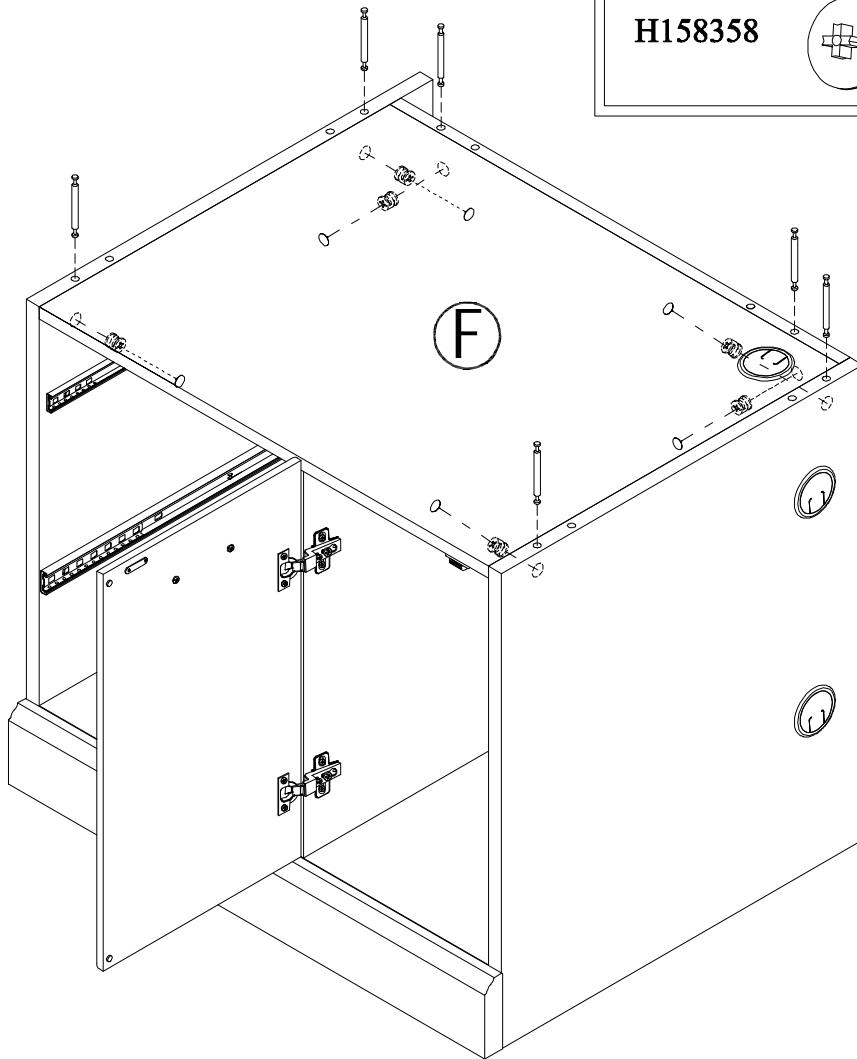

? 1 - 800 - 950 - 4782

A159906

STEP 6

H158136

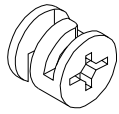

[6]

H157902

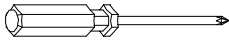

H157939

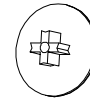

[6]

6399CS

H158358

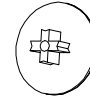

[6]

6399MC

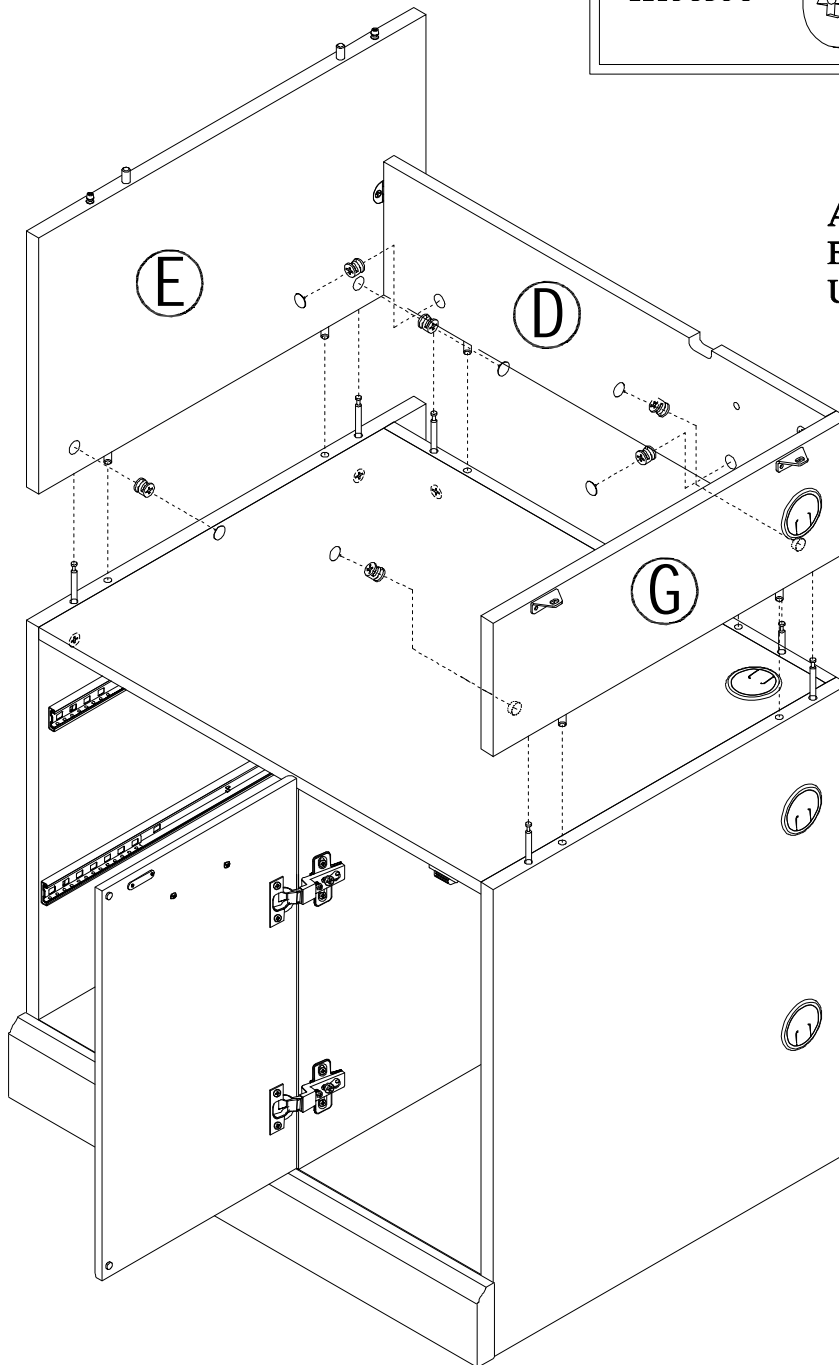

An assistant is required.
Es necesario un ayudante.
Un assistant est nécessaire.

? 1 - 800 - 950 - 4782

A159906

STEP 7

H157569

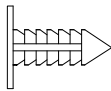

[2]

H157573



[2]

H158135



[6]

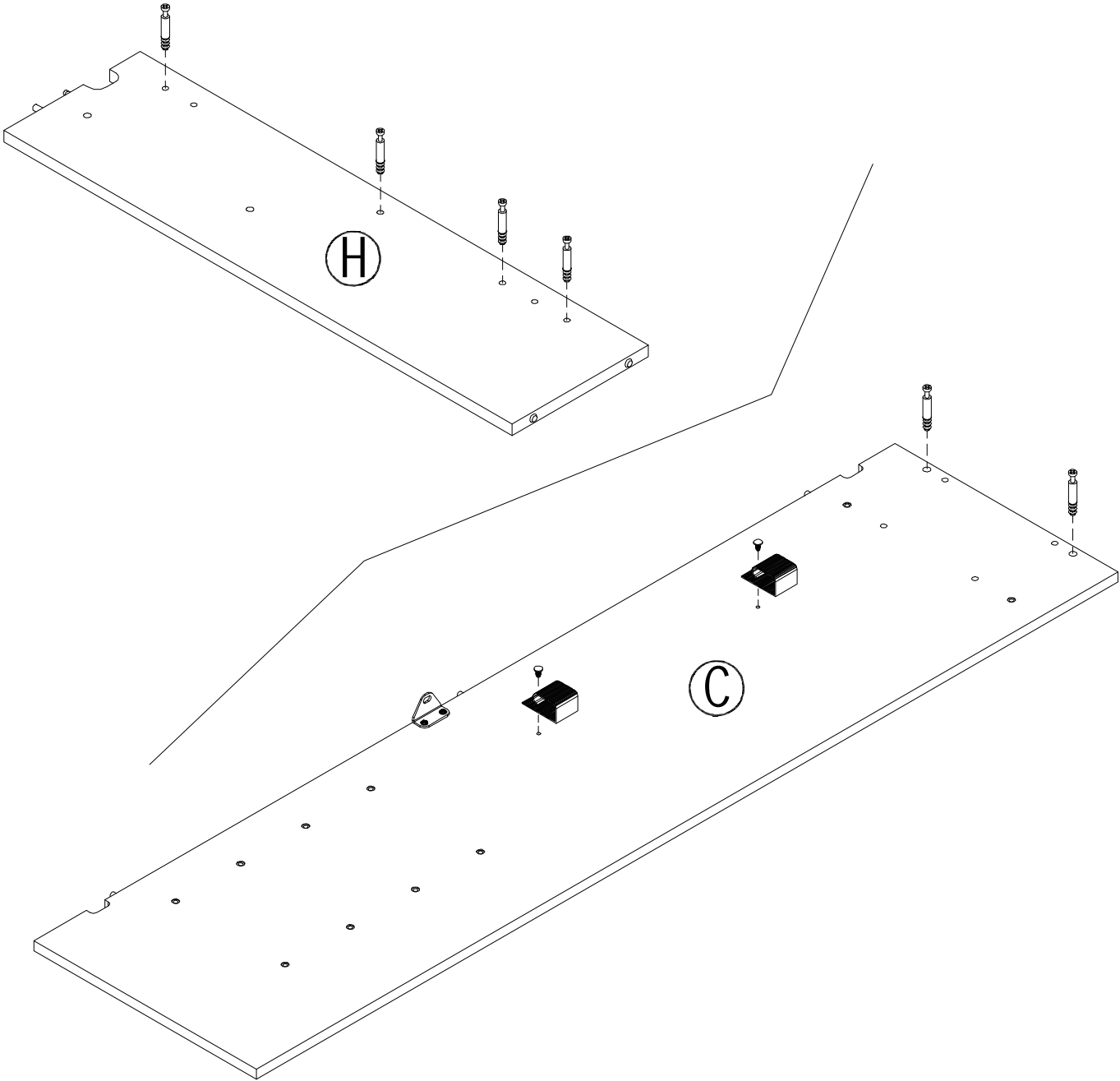

? 1 - 800 - 950 - 4782

A159906

STEP 8

H158139

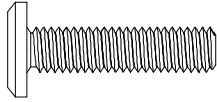

[2]

H158990

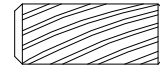

[2]

H157902

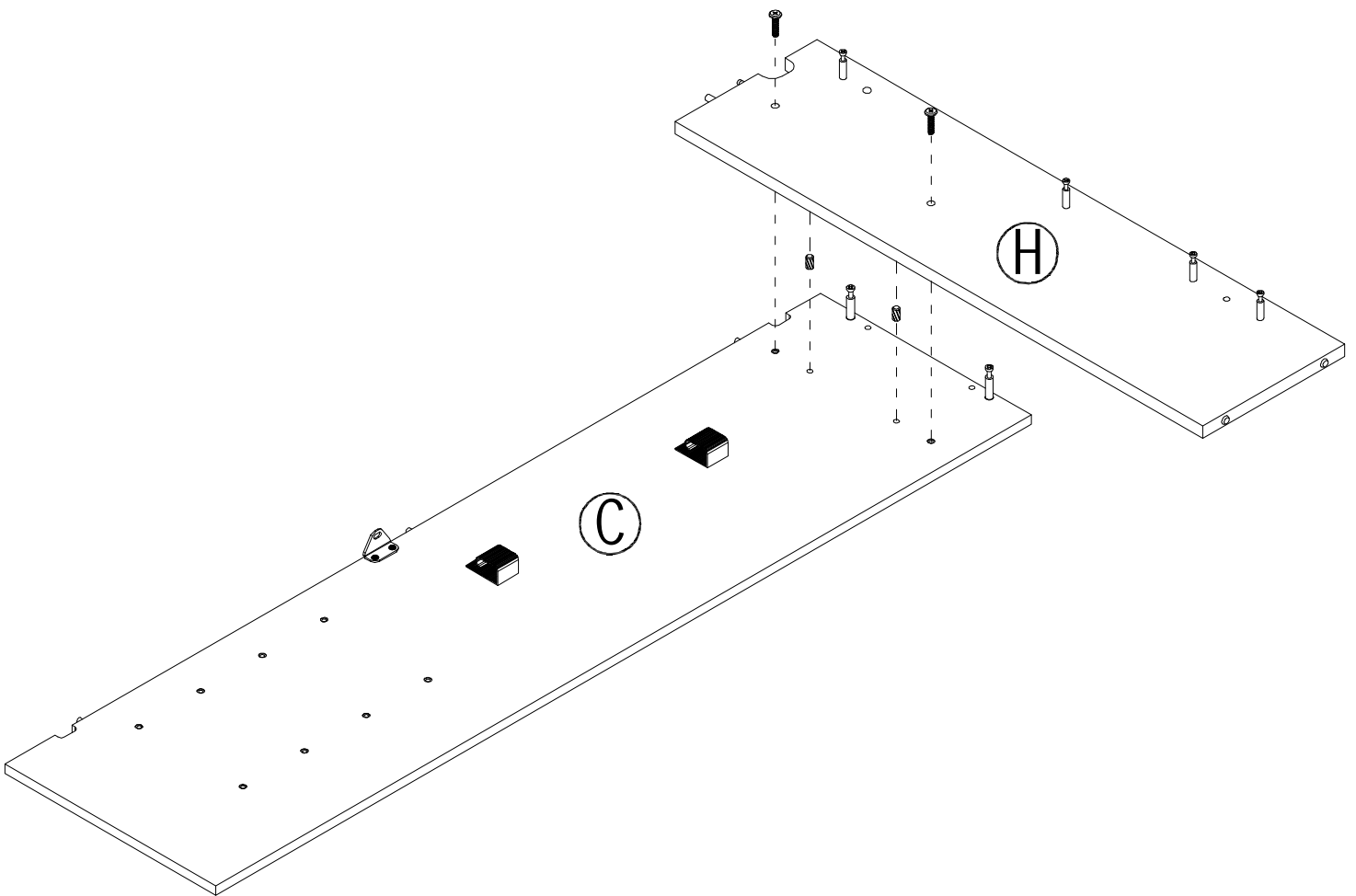
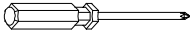

? 1 - 800 - 950 - 4782

A159906

STEP 9

H158135



[4]

H157902

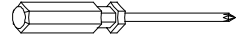

H67187

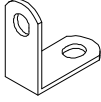

[1]

H157928

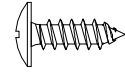

[1]

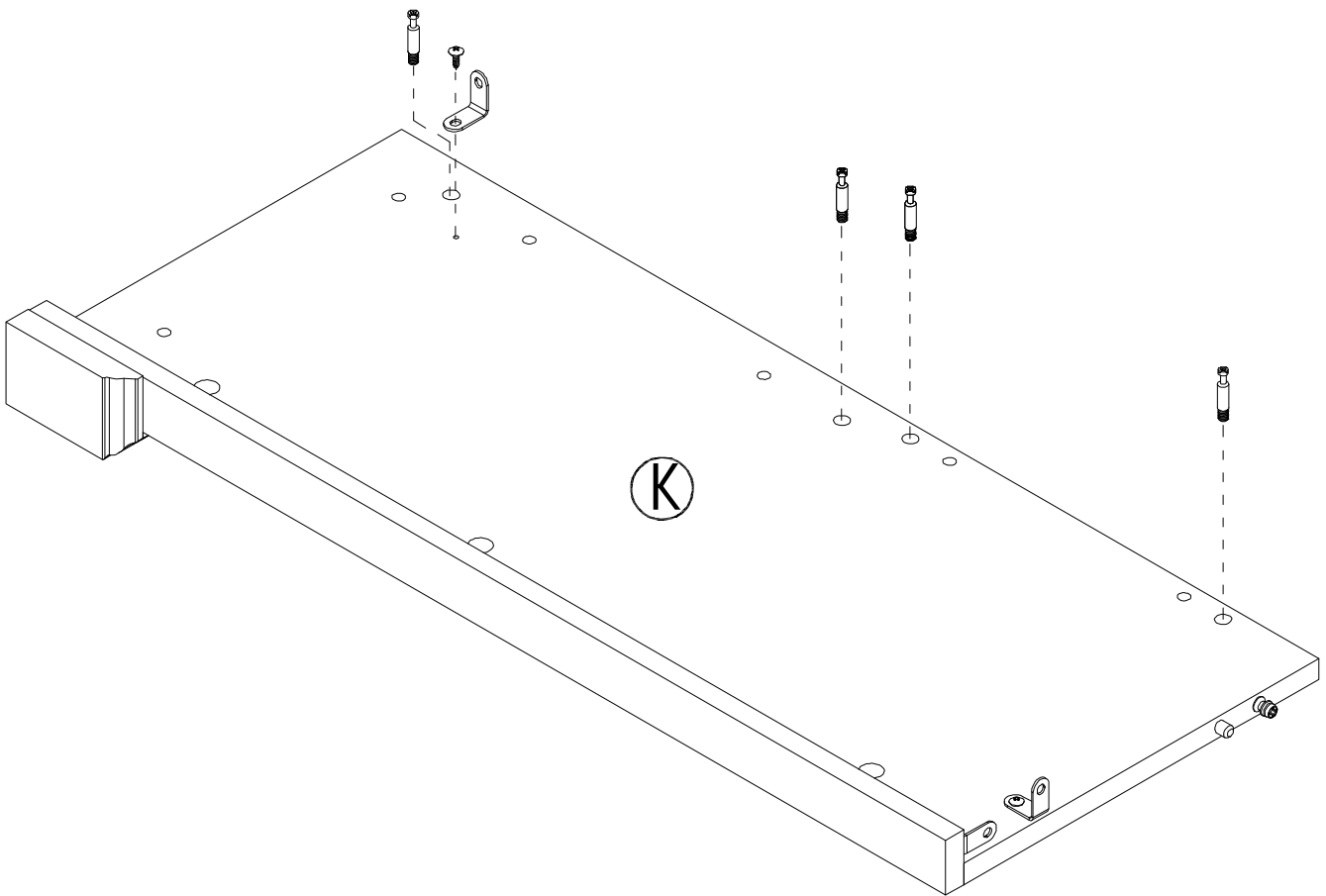

? 1 - 800 - 950 - 4782

A159906

STEP 10

H158139

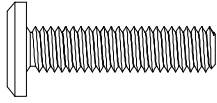

[4]

H158990

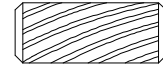

[4]

H157902

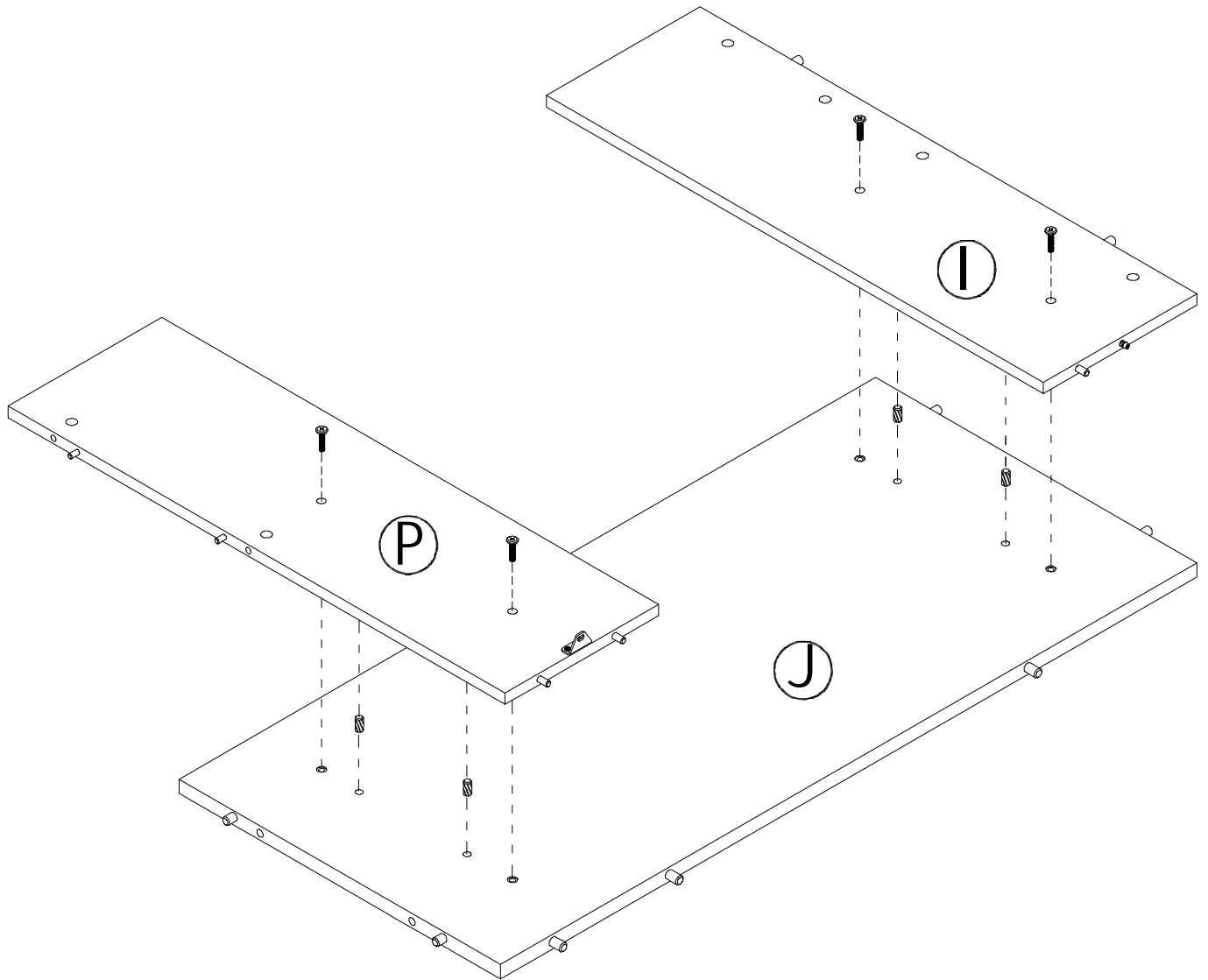
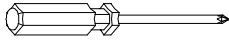

? 1 - 800 - 950 - 4782

A159906

STEP 11

H158136



[6]

H157902

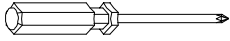

An assistant is required.
Es necesario un ayudante.
Un assistant est nécessaire.

H157939



[6]

6399CS

H158358



[6]

6399MC

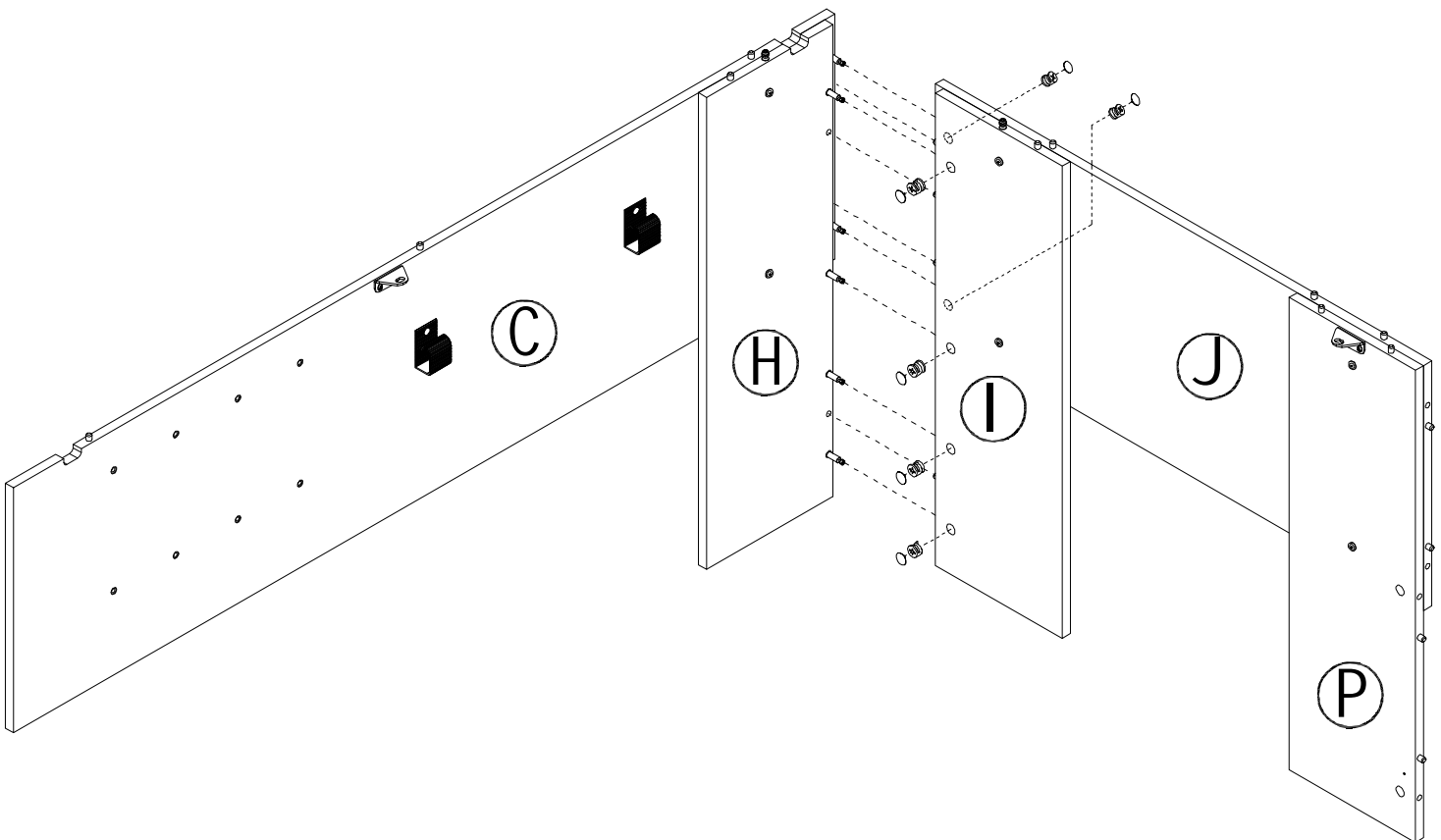



? 1 - 800 - 950 - 4782

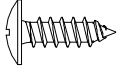

A159906

STEP 12

H158136  [4]

H157928  [1]

H157902 

H157939 	[4]	6399CS
H158358 	[4]	6399MC

An assistant is required.
Es necesario un ayudante.
Un assistant est nécessaire.

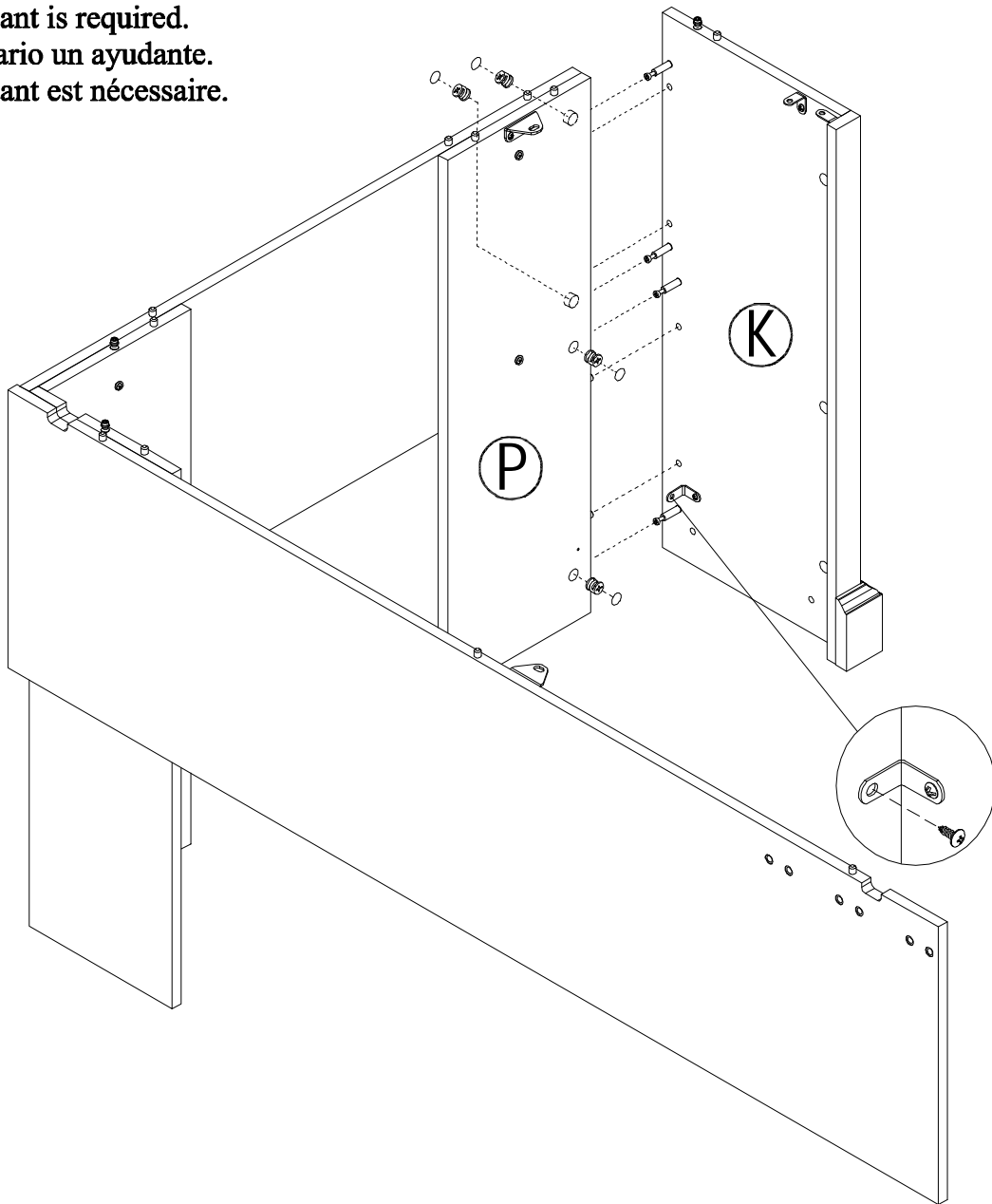

? 1 - 800 - 950 - 4782

A159906

STEP 13

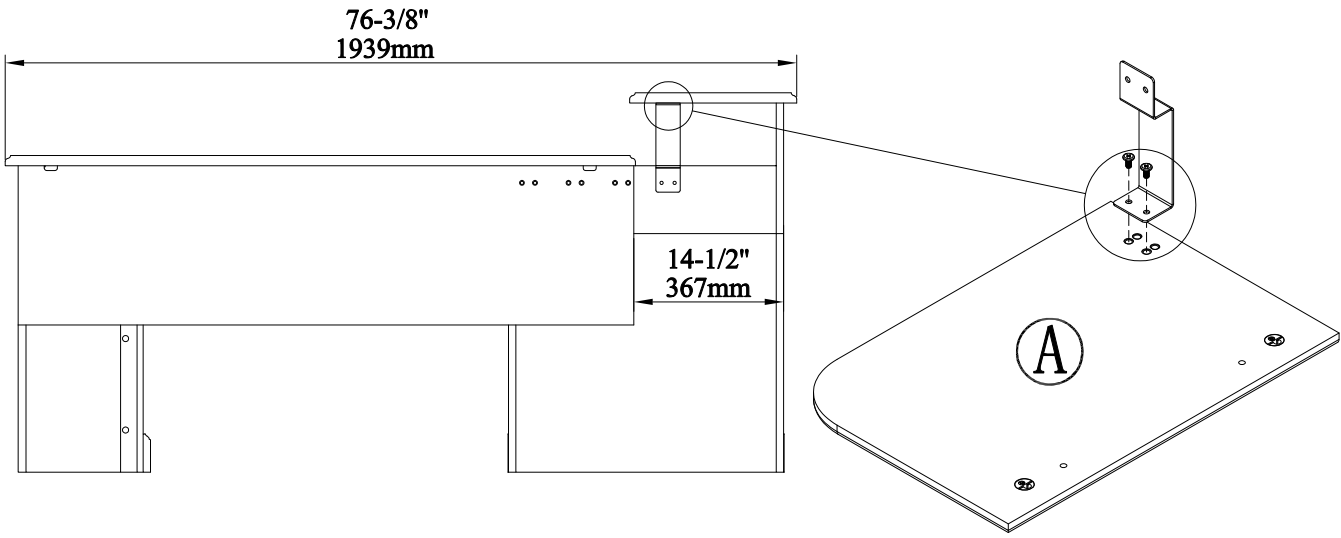
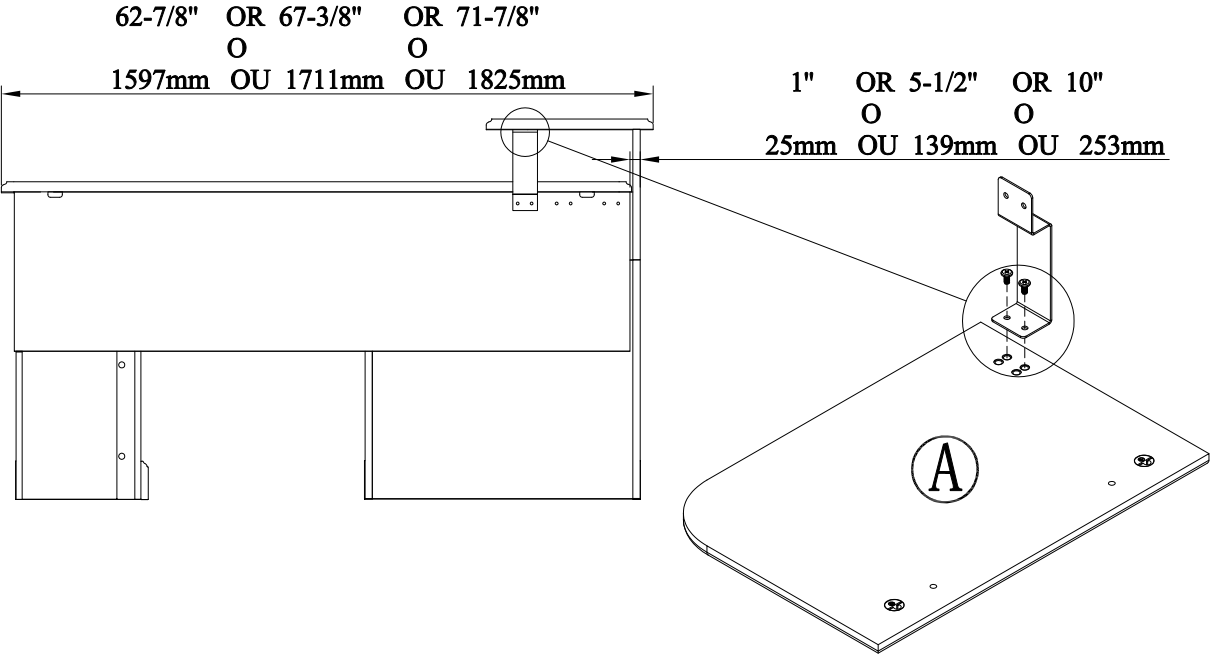

? 1 - 800 - 950 - 4782

A159906

STEP 14

H158139

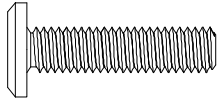

[2]

H157902

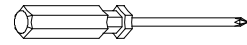

An assistant is required.
Es necesario un ayudante.
Un assistant est nécessaire.

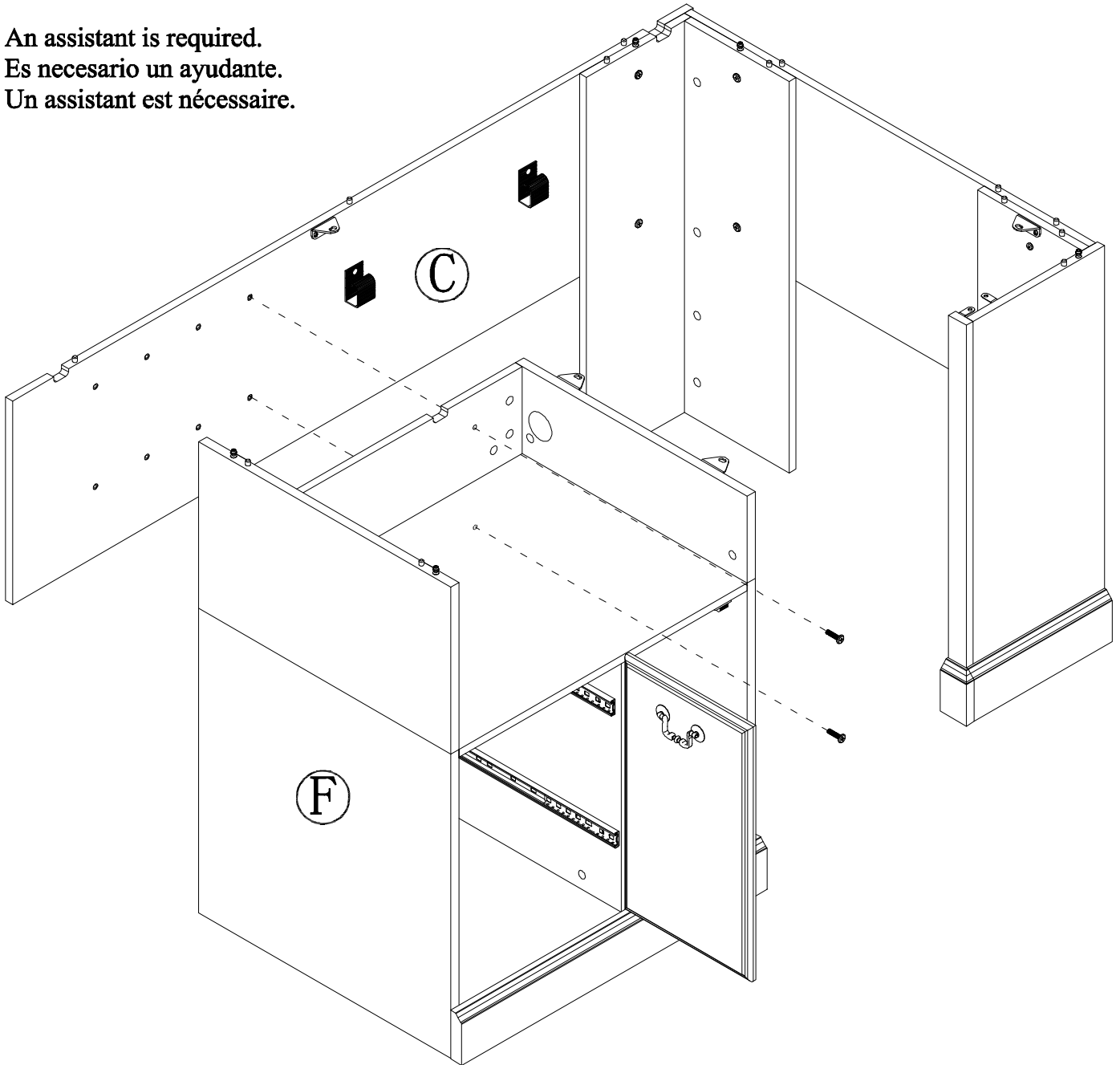

? 1 - 800 - 950 - 4782

A159906

STEP 15

H158138

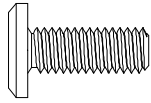

[6]

H157520

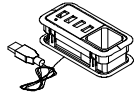

[1]

H157902

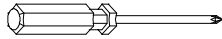

H158143

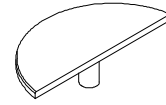

[3]

6399CS

H158357

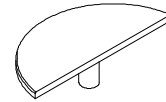

[3]

6399MC

An assistant is required.
Es necesario un ayudante.
Un assistant est nécessaire.

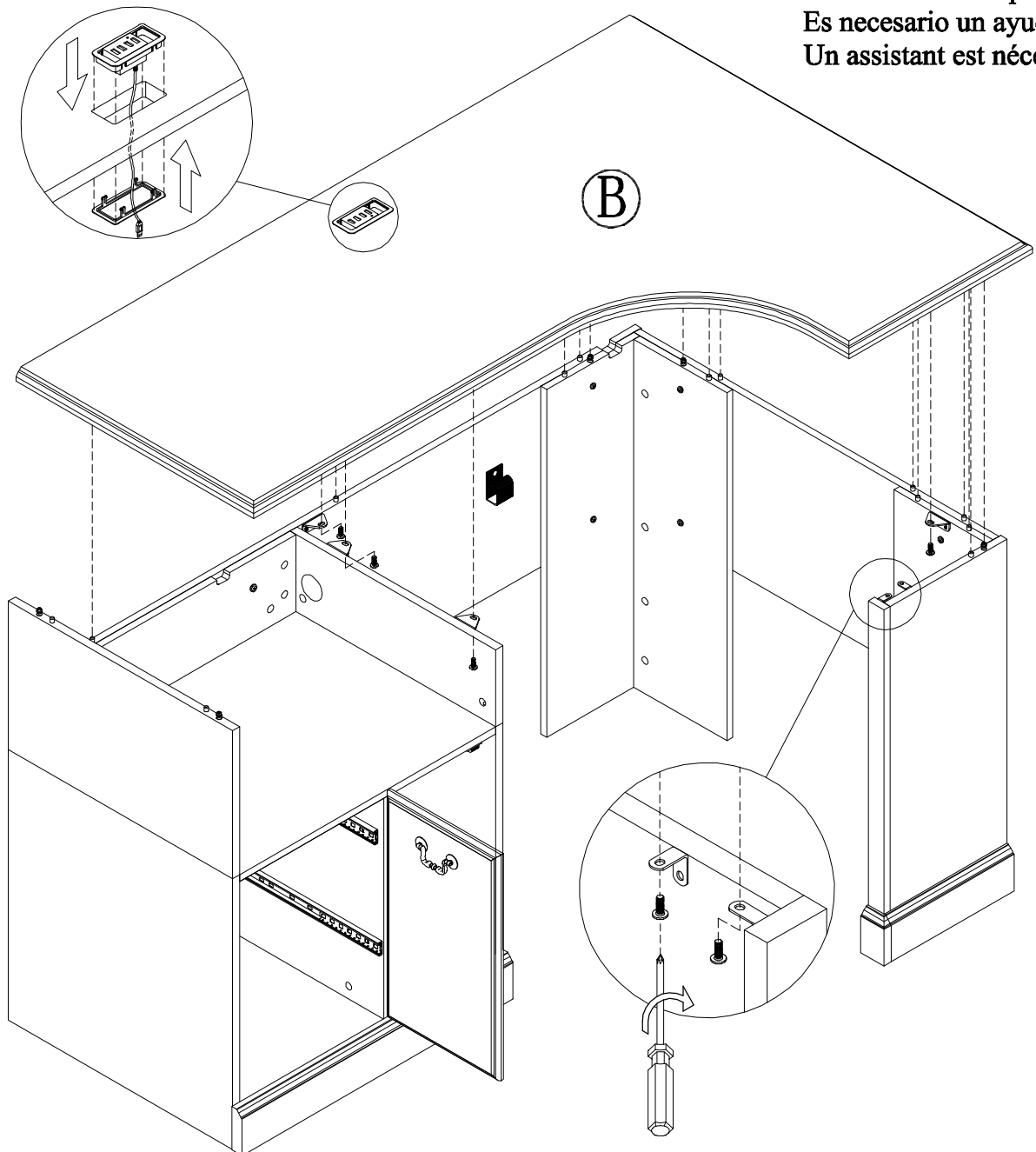

? 1 - 800 - 950 - 4782

A159906

STEP 16

H158989

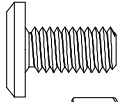

[4]

H158991

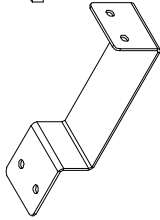

[1]

H157902

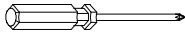

H158143

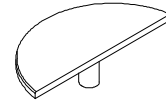

[3]

6399CS

H158357

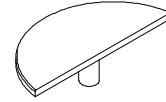

[3]

6399MC

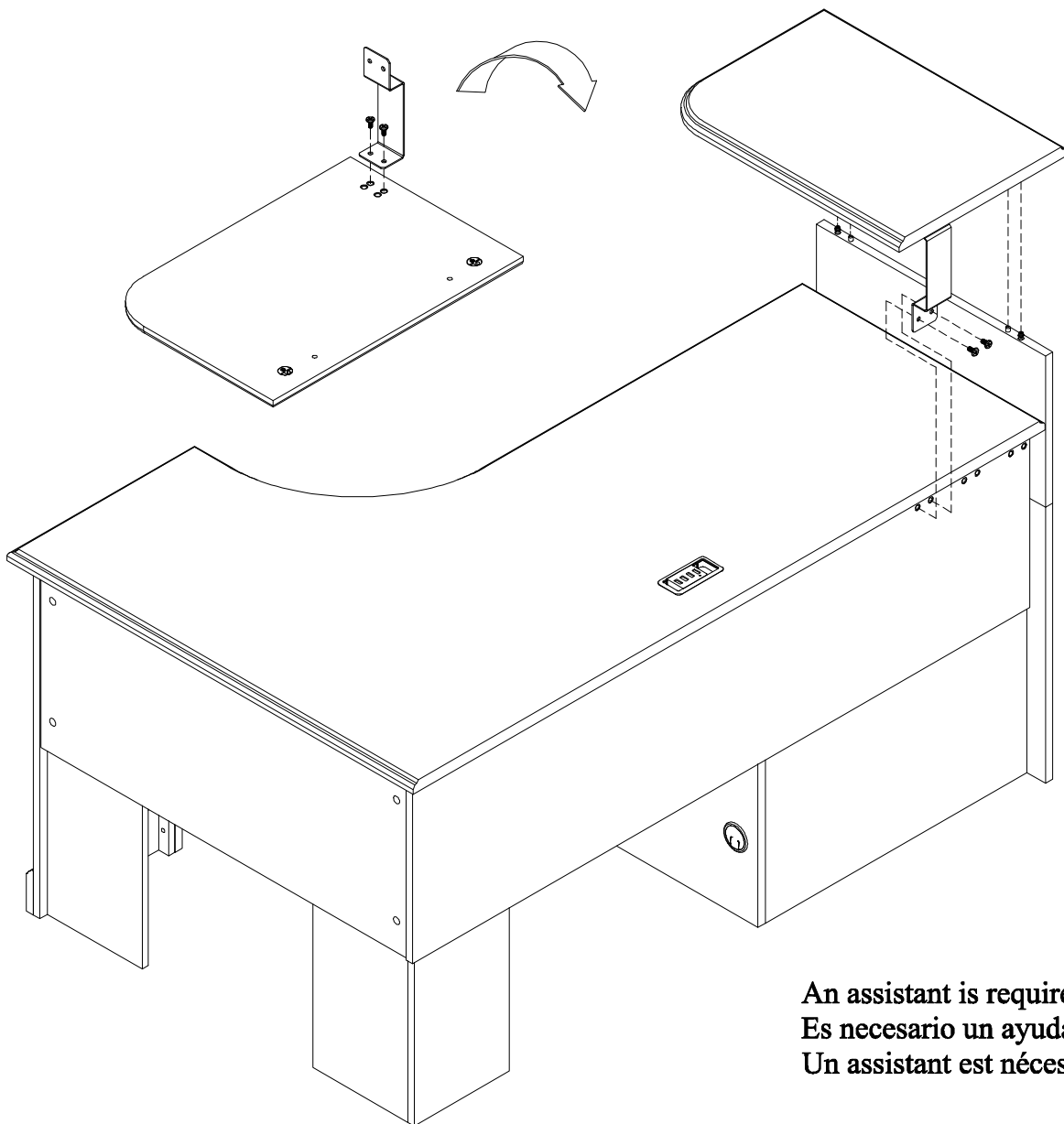

An assistant is required.
Es necesario un ayudante.
Un assistant est nécessaire.

? 1 - 800 - 950 - 4782

A159906

STEP 17

H157876



[2]

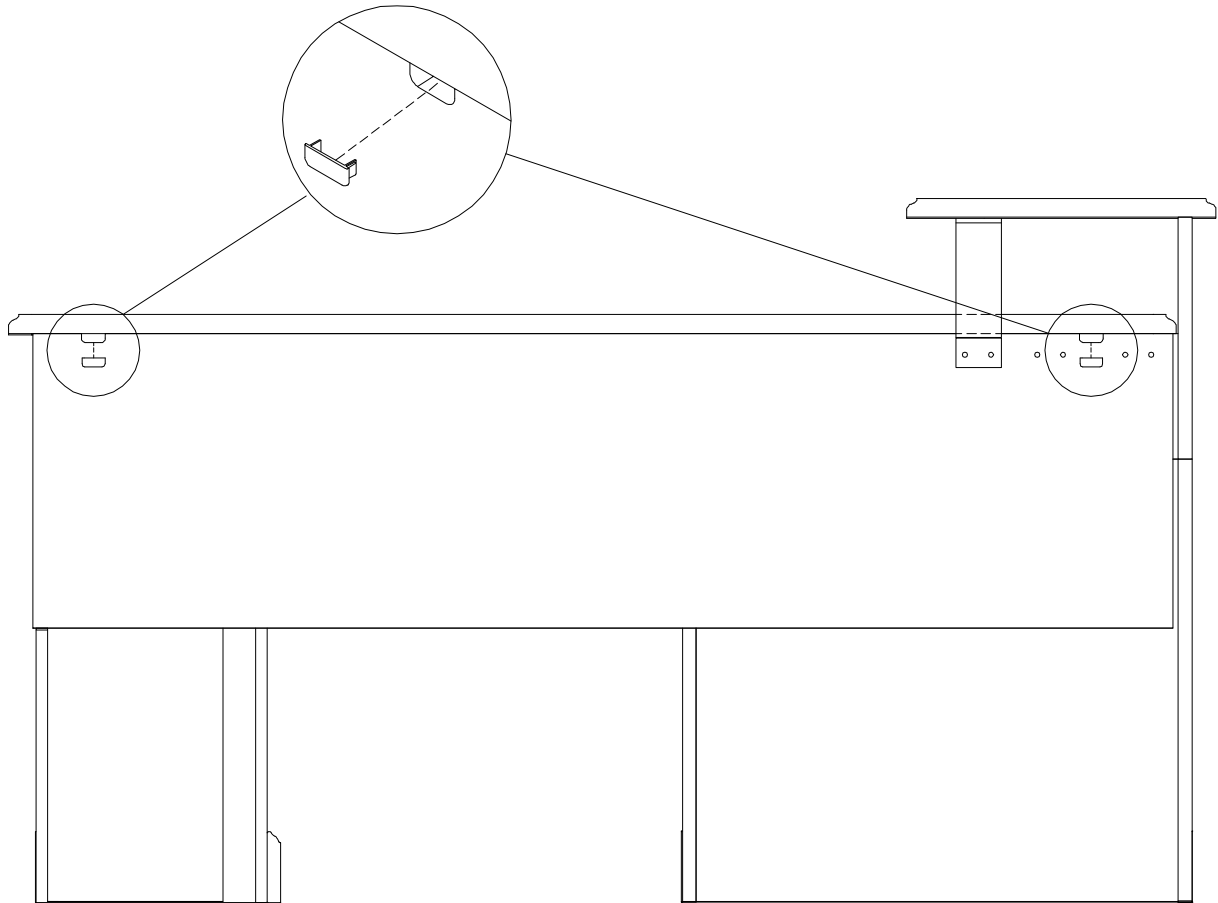

? 1 - 800 - 950 - 4782

A159906

STEP 18

H158142



[1]

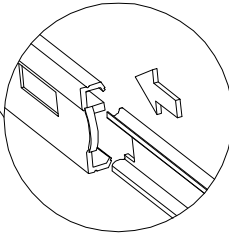
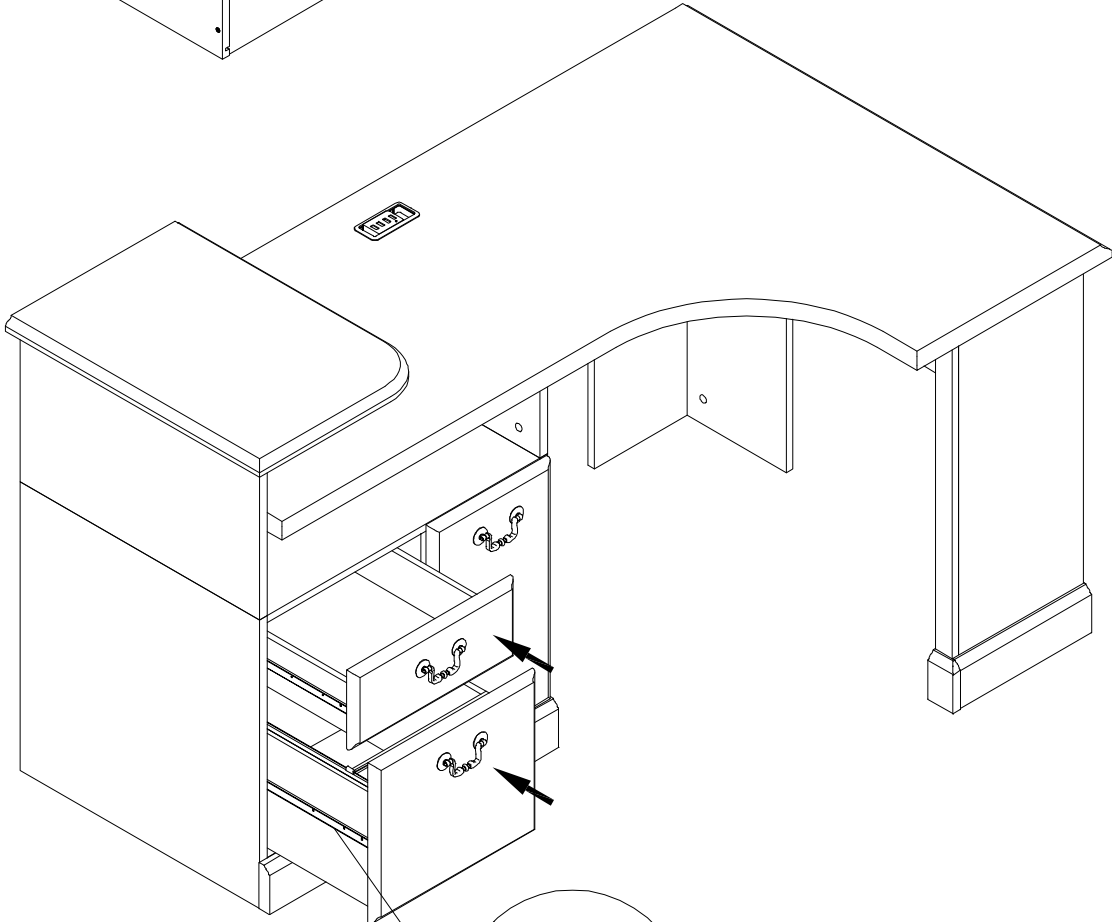
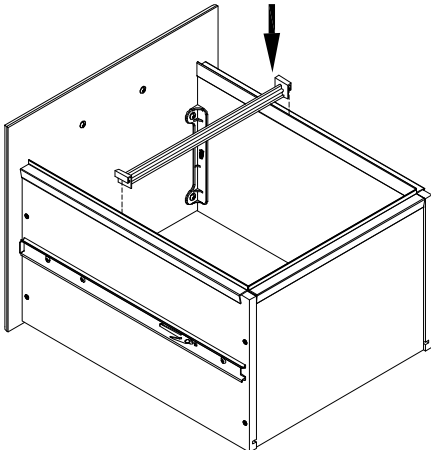

? 1 - 800 - 950 - 4782

A159906

STEP 19

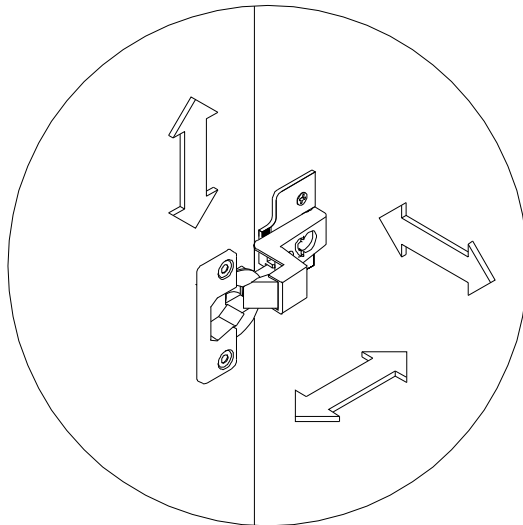
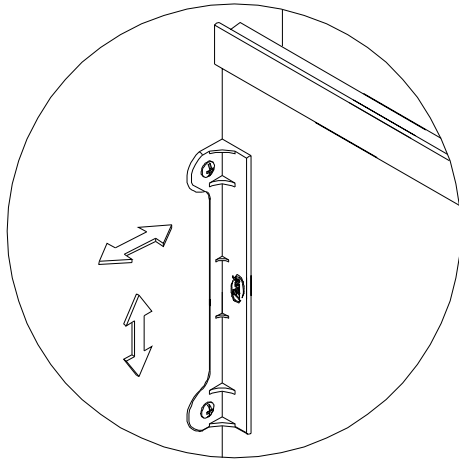
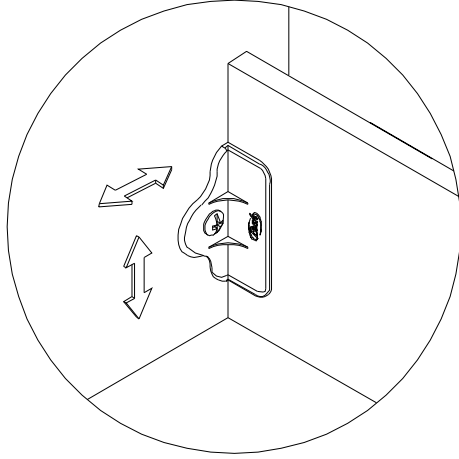

? 1 - 800 - 950 - 4782

A159906

STEP 20

- Move unit to final location.
- Coloque esta unidad en su posición permanente.
- Déplacez l'unité dans l'endroit final.

- Adjust drawer fronts as shown below.
- Ajuste la parte delantera de las gavetas según es indicado.
- Ajustez les façades de tiroir comme montré ci-dessous.

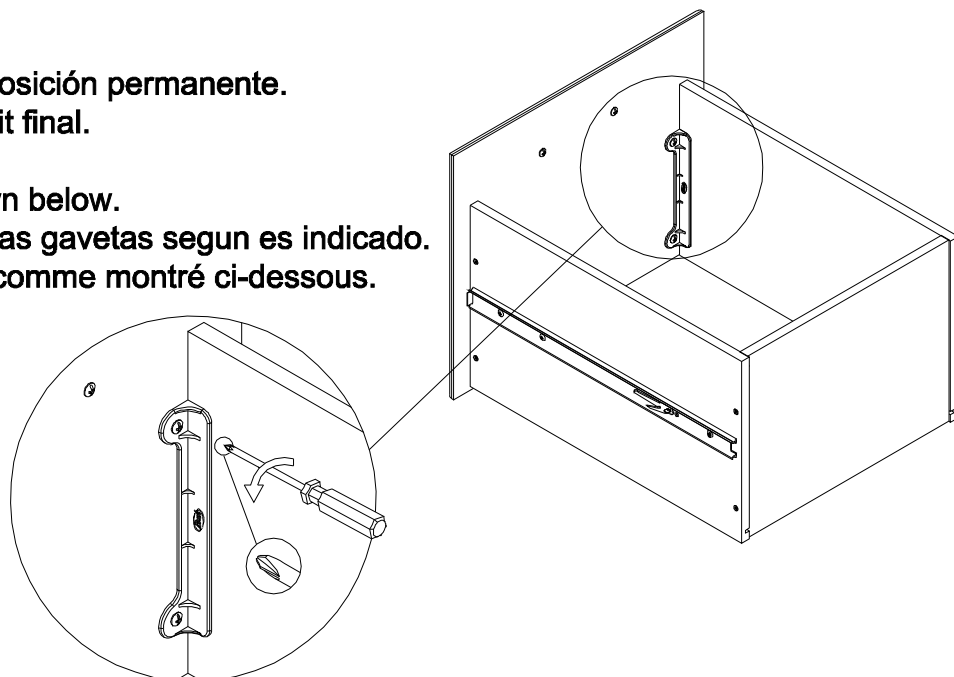

STEP 1.

- Loosen screws on back of drawer front brackets as shown.
- Afloje los tornillos en la parte trasera de la gaveta según es indicado.
- Desserrez les vis dans les appuis en plastique sur le dos de l'avant de tiroir comme montré.

STEP 2.

- Position drawer front as required.
- Ajuste la parte delantera de la gaveta según sea necesario.
- Placez l'avant de tiroir comme nécessaire.

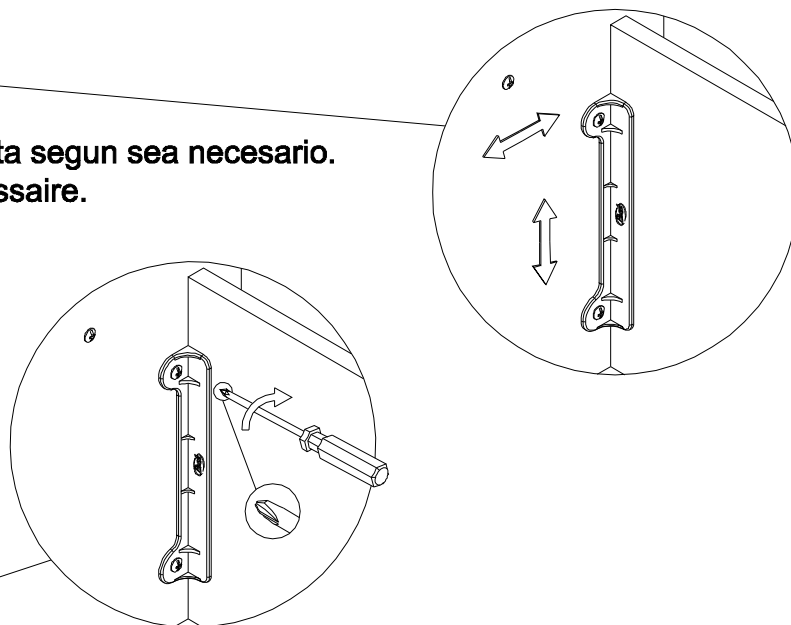

STEP 3.

- Tighten screws while holding drawer front in position.
- Apriete los tornillos mientras sujeta la parte delantera de la gaveta en su posición permanente.
- Serrez les vis tout en tenant l'avant de tiroir en position.

STEP 21

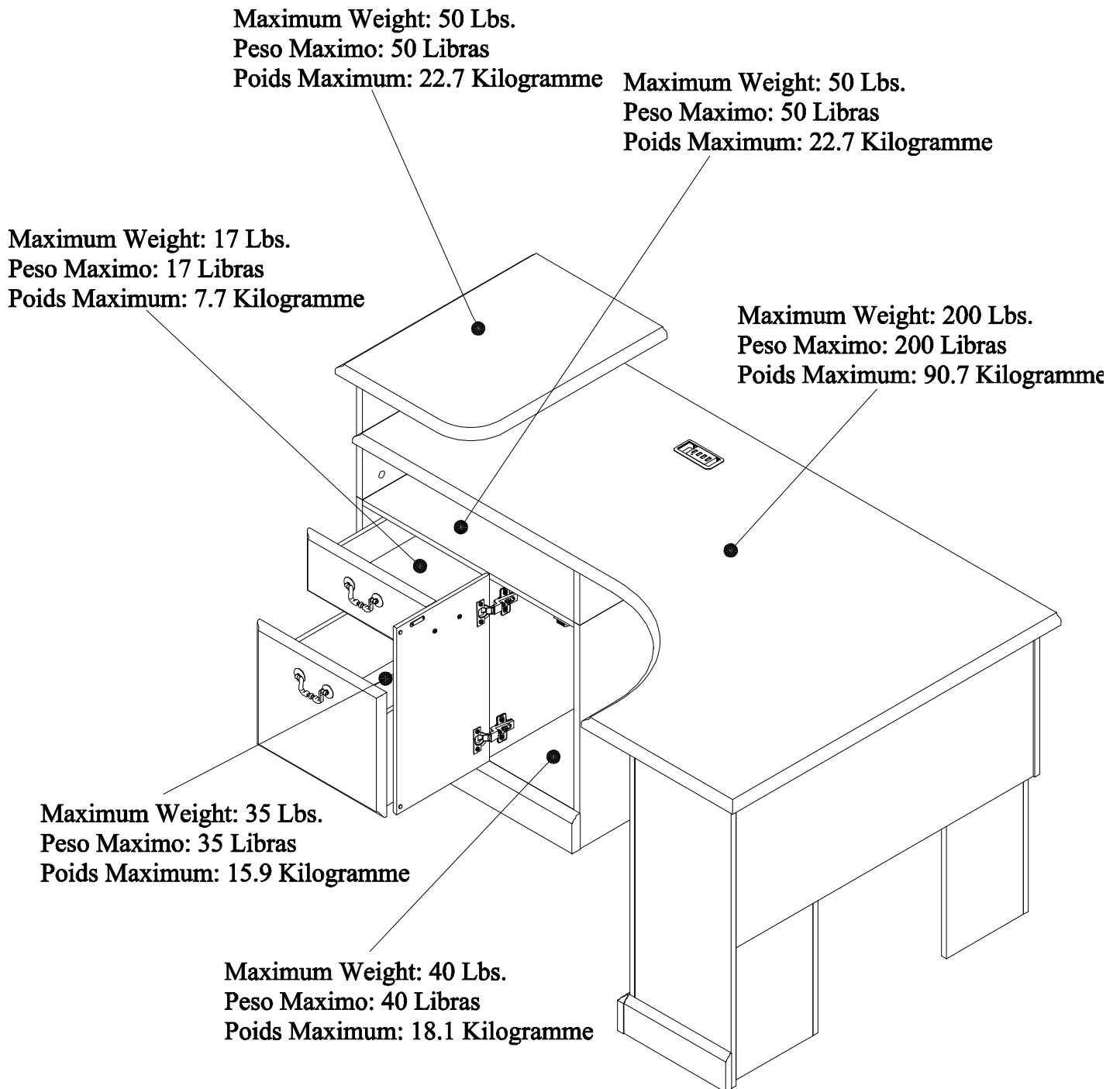

? 1 - 800 - 950 - 4782

A159906