

an LDI Company
New Hope, MN 55428
Visit us on the web:
www.safcoproducts.com

ASSEMBLY INSTRUCTIONS

READ THESE INSTRUCTIONS BEFORE STARTING! FOLLOW THE ASSEMBLY PROCEDURES CAREFULLY.

PRODUCT WARRANTY REGISTRATION is available online at: www.safcoproducts.com

TOOLS REQUIRED: Phillips Screwdriver (Two People Recommended)

Please read these instructions before starting. Follow the assembly procedures carefully.

PARTS LIST			
CODE	DESCRIPTION	QTY.	PART NO.
A	Base	1	3450-02
B	Caster	5	3400-75
C	Cylinder	1	5102-11
D	Cylinder Cover	1	3450-14
E	Seat Assembly	1	
	Cloth		3450-01§
	Vinyl		3445-01BL
F	Back Rest Cushion	1	
	High Backrest - Cloth		3450-03§
	High Backrest - Vinyl		3445-03BL
	Mid Backrest - Cloth		3451-03§
	Mid Backrest - Vinyl		3446-03BL
G	Backrest Cover	1	
	High Backrest Cover		3450-04
	Mid Backrest Cover		3451-04
H	Left Arm Assembly	1	3450-05
I	Right Arm Assembly	1	3450-06

§ Note: When corresponding about parts, be sure to state color: Burgundy (BG), Black (BL), Blue (BU), Charcoal (CH), Cobblestone Black (CB), Cobblestone Blue (CL) or Cobblestone Plum (CP).

HARDWARE PACK 3450-19		
J		L
Chair Bolt QTY: 8 #3450-22	K	Small Washer QTY: 8 #3450-23
		Large Washer QTY: 8 #3450-24

ATTENTION:

Please do not attach the Backrest Cover **G** onto the Backrest Cushion **F** until **Step 6!** The Backrest Cushion must be attached to the Arm Assemblies before you can put the Backrest Cover on the Backrest Cushion!

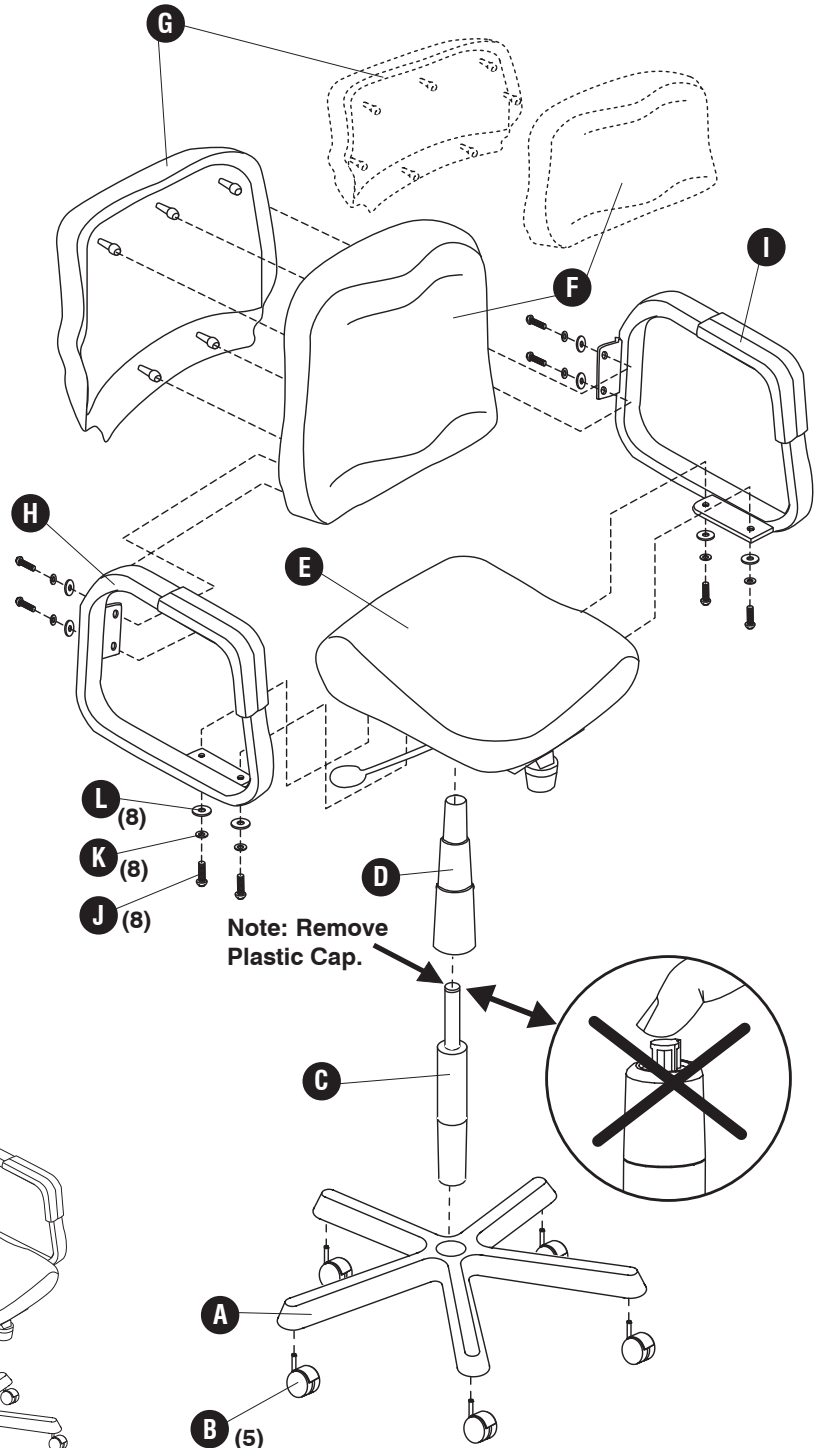
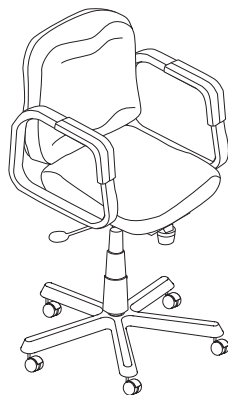

1

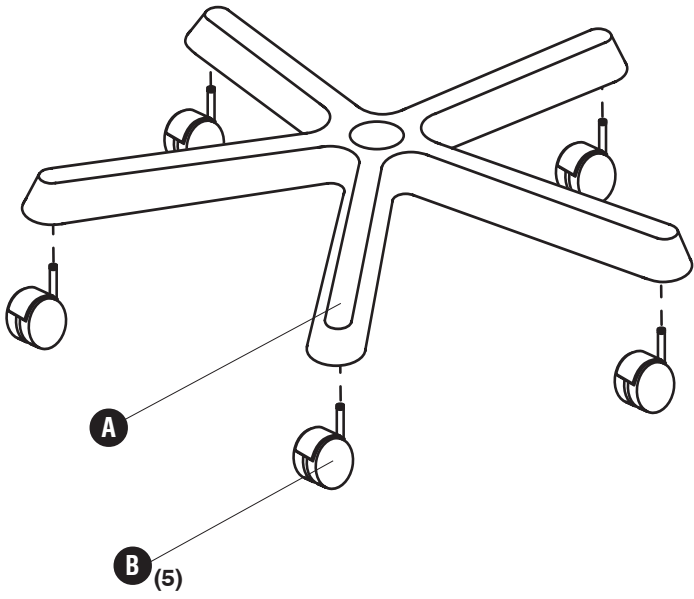

2

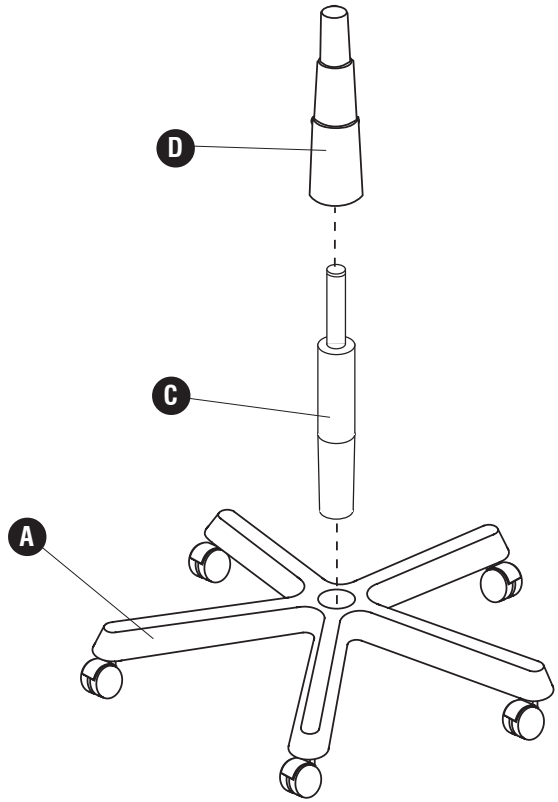

3 Press down firmly (or sit) to lock into place.

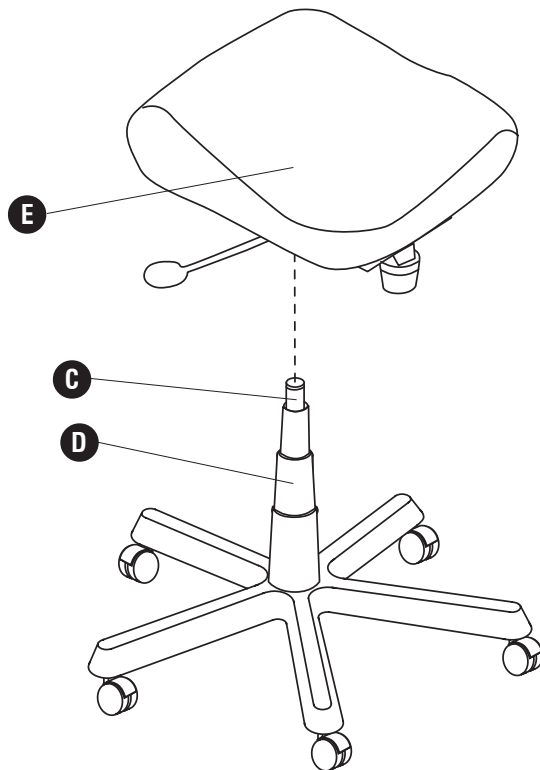



ATTENTION:

For **Steps 4 and 5**, temporarily fasten the chair bolts “finger-tight”, do NOT fully tighten the screws until all bolts are properly inserted. Then go back and tighten each screw evenly using a screwdriver.

NOTE: The brackets on the arms will be on the interior of the chair, as shown.

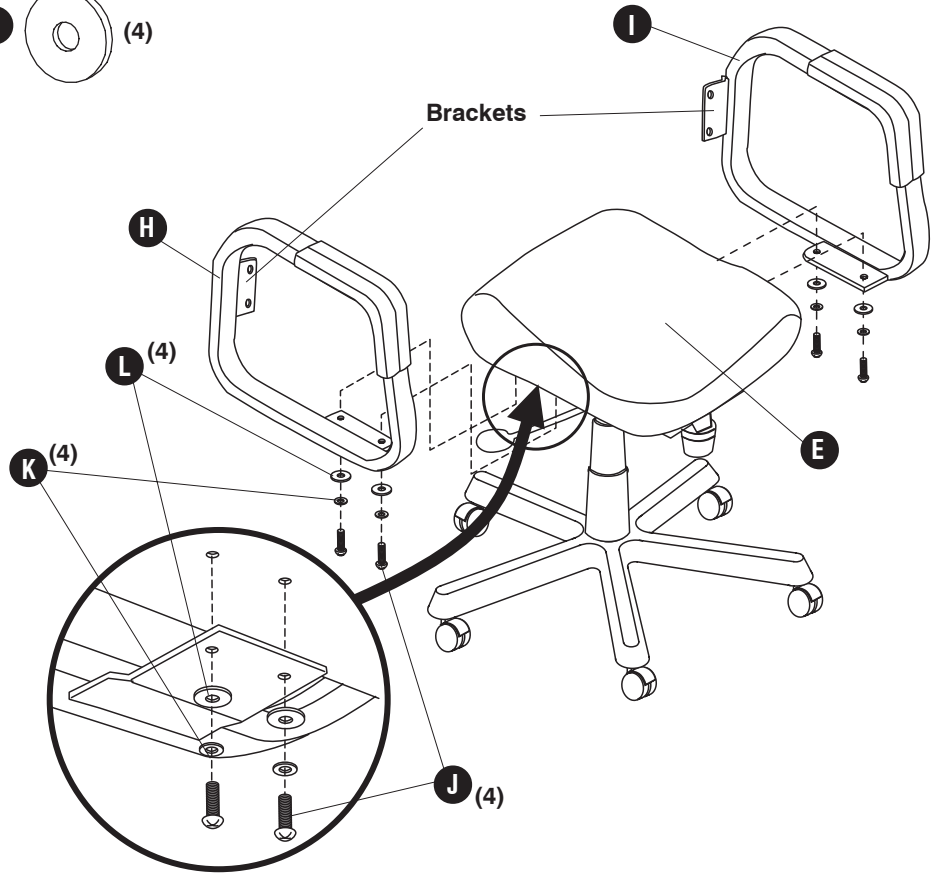

Do not attach Backrest Cover until **Step 6**.

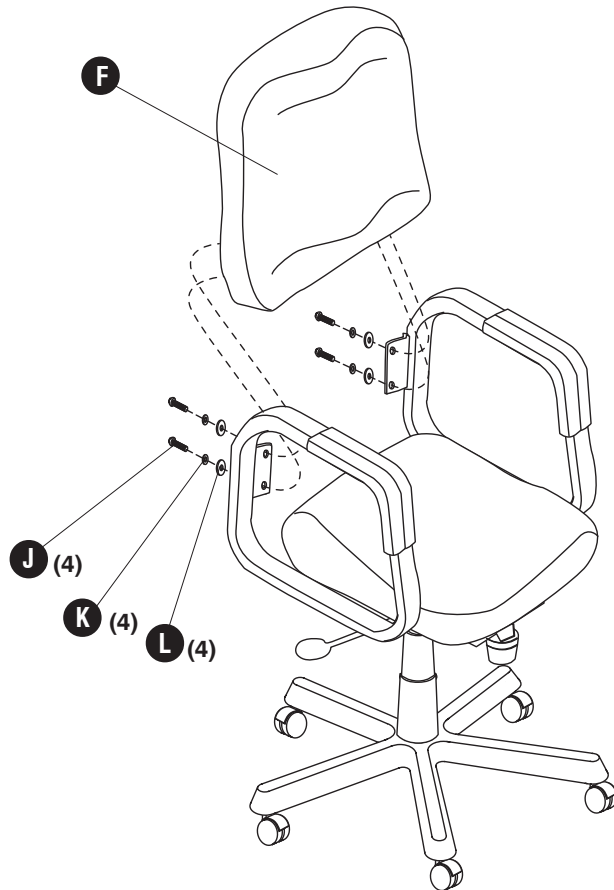
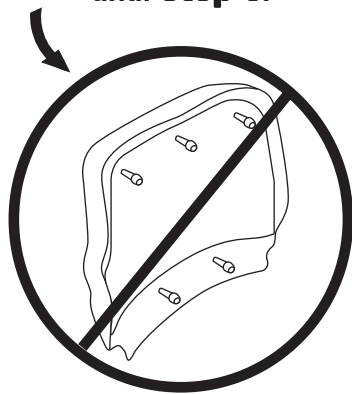

6

IMPORTANT: Follow the installation sequences below.

Installing the Mid Backrest Cover

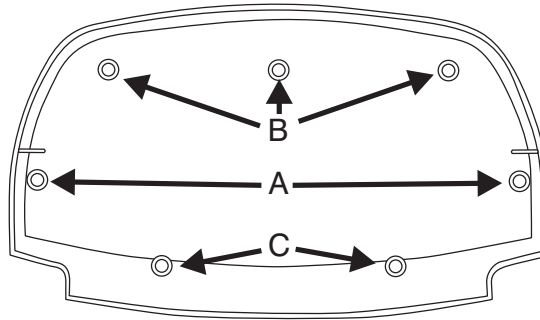
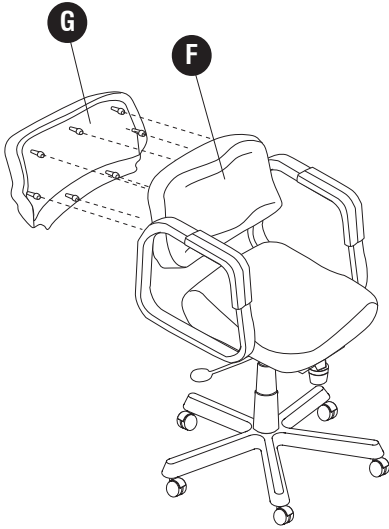

1. Squeeze in **A** first.
2. Squeeze in **B** second.
3. Squeeze in **C** last.

Installing the High Backrest Cover

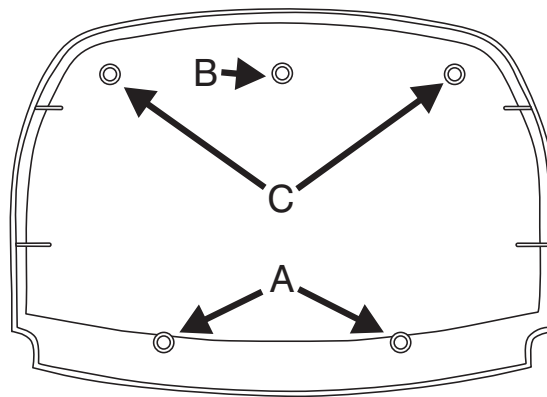

1. Squeeze in **A** first.
2. Squeeze in **B** second.
3. Squeeze in **C** last.

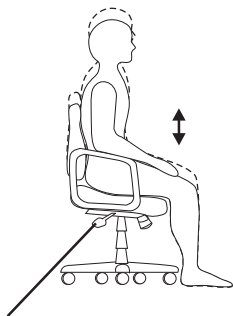

Height Adjustment Lever

1. Height Adjustment:

- Sit deep into the chair and place your feet flat on the floor.
- Lift the lever and adjust height so you feel **NO** pressure under the back of your thighs.

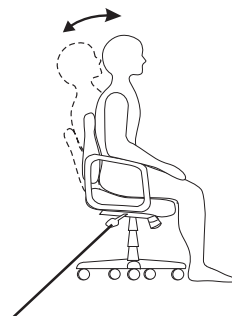

Height Adjustment Lever

2. Vertical Lock Control:

- To lock the chair in a vertical position and prevent rocking, push the height adjustment lever under the seat into the seat mechanism.
- Release the lock feature by pulling the lever out.

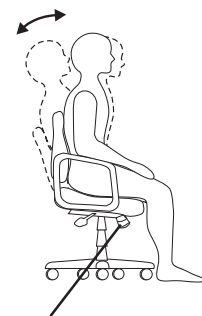

Tilt Adjustment Knob

3. Adjust Tilt Flexibility:

- Adjust the flexibility of the seat by turning the tilt adjustment knob in front to the right or left as desired.

an LDI Company

New Hope, MN 55428

S'il vous plaît visiter-nous sur l'Internet :
www.safcoproducts.com

INSTRUCTIONS DE MONTAGE

LIRE CES INSTRUCTIONS AVANT DE COMMENCER LE MONTAGE! SUIVRE LES ÉTAPES DE MONTAGE AVEC SOIN.

Le formulaire d'inscription de garantie du produit est disponible à : www.safcoproducts.com

OUTILS REQUIS: Tournevis à Pointe Cruciforme (On recommande que l'assemblage soit effectué par deux personnes.)

S'il vous plaît lire ces Instructions avant de commence le Montage. Suivre les étapes de montage avec soin.

LISTE DES PIÈCES			
CODE	DESCRIPTION	QTÉ.	N° DE PIÈCE
(A)	Base	1	3450-02
(B)	Roues	5	3400-75
(C)	Cylindre pneumatique	1	5102-11
(D)	Carter du cylindre	1	3450-14
(E)	L'assemblage du siège		
	Tissu	1	3450-01§
	Vinyle	1	3445-01BL
(F)	Le Dossier-lit		
	Haut Dossier-lit - Tissu	1	3450-03§
	Haut Dossier-lit - Vinyle	1	3445-03BL
	Mi Dossier-lit - Tissu	1	3451-03§
	Mi Dossier-lit - Vinyle	1	3446-03BL
(G)	Carter pour le Dossier-lit	1	
	Carter pour le Haut Dossier-lit		3450-04
	Carter pour le Mi Dossier-lit		3451-04
(H)	L'Assemblée du Bras gauche	1	3450-05
(I)	L'Assemblée du Bras droite	1	3450-06

§ Noter : Quand correspondre au sujet de parties, soyez sûr d'affirmer la couleur: Bordeaux (BG), Noir (BL), Bleu (BU), Gris Foncé (CH), Noir du Pavé (CB), Bleu du Pavé (CL) ou Prune du Pavé (CP).

PAQUET MATÉRIEL 3450-19			
(J)		(L)	
Boulon de la Chaise QTÉ: 8 #3450-22	(K)	Petite Rondelle QTÉ: 8 #3450-23	Grande Rondelle QTÉ: 8 #3450-24

ATTENTION:

S'il vous plaît n'attachez pas le Carter pour le Dossier-lit (G) sur le Coussin de Dossier-lit (F) jusqu'à la **Directive 6!** Le Coussin de Dossier-lit doit être attaché aux Assemblées du Bras avant que vous puissiez mettre le Carter pour le Dossier-lit sur le Coussin de Dossier-lit!

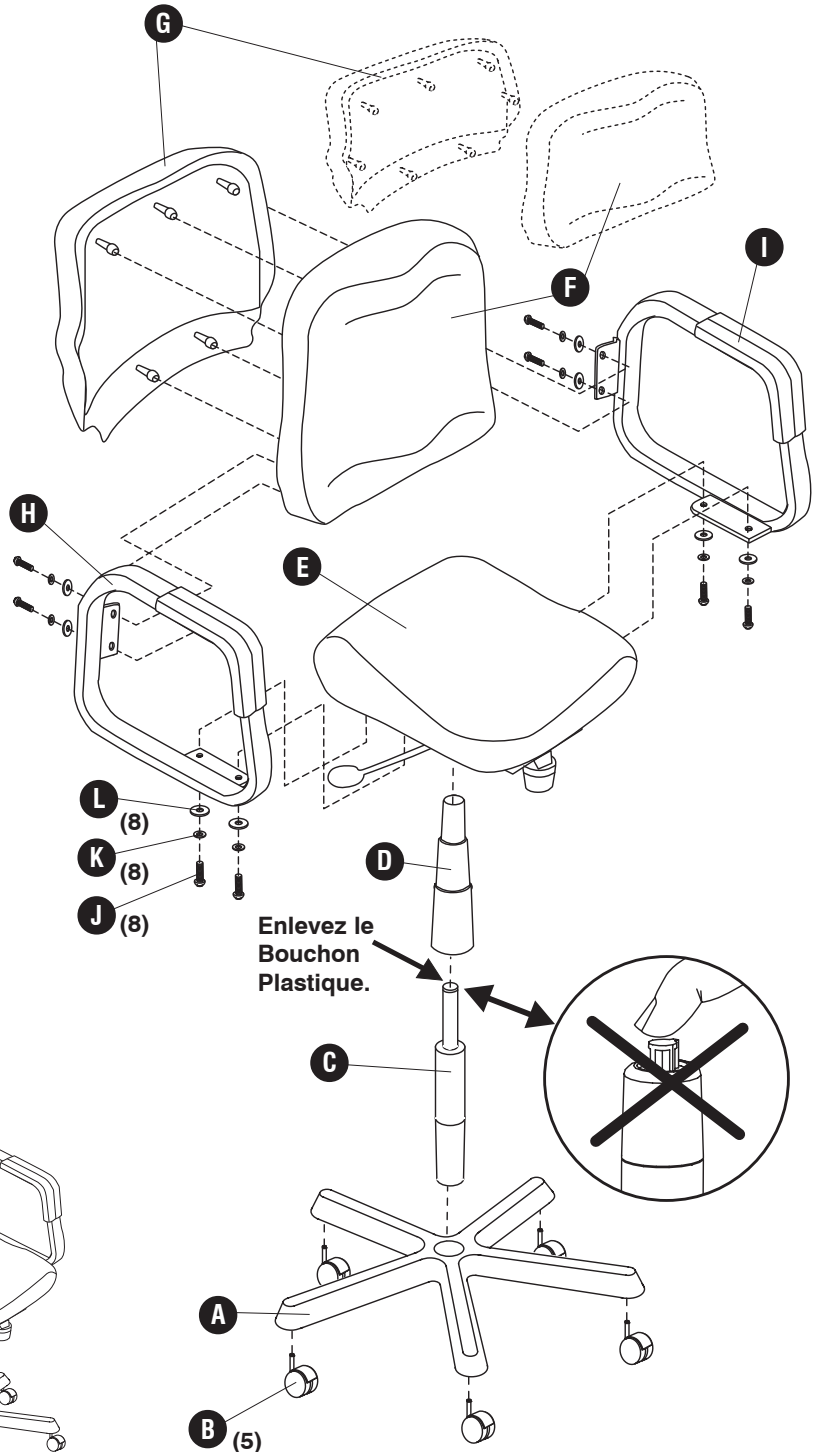
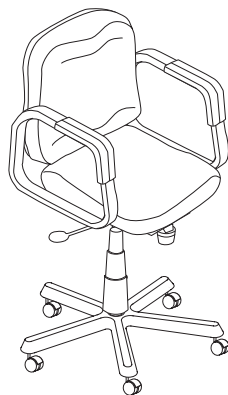

1

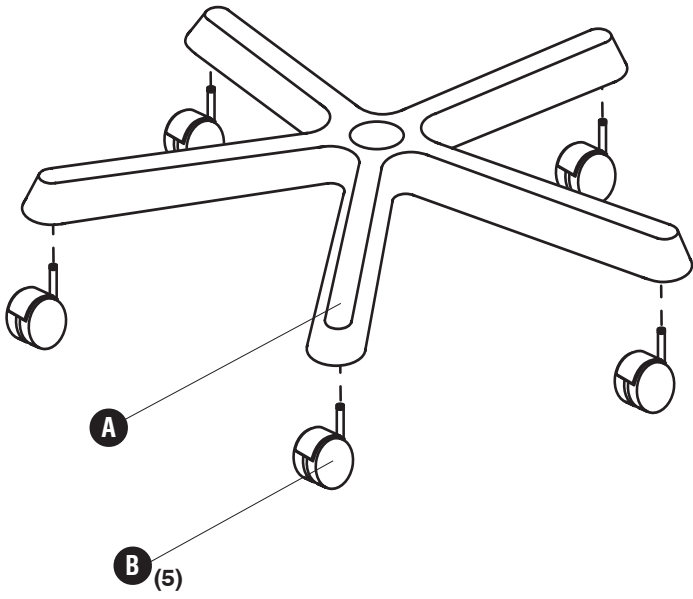

2

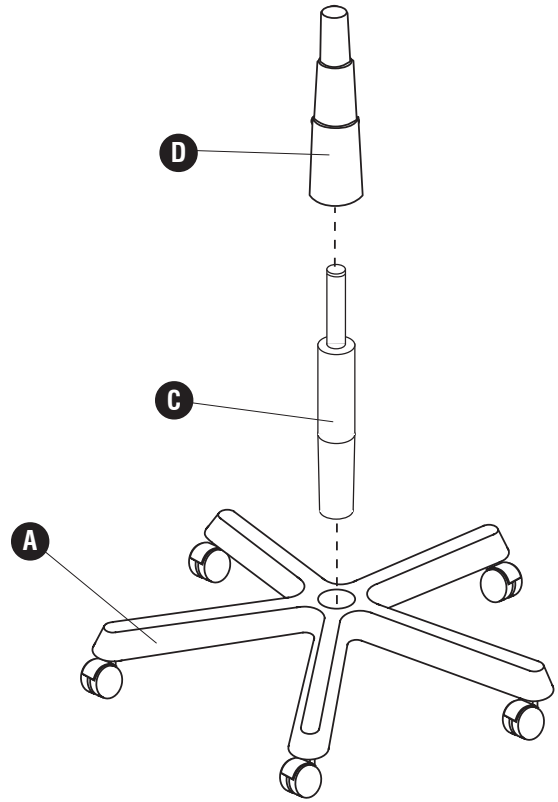

3 **Pressez le siège vers le bas fermement (ou asseyez-vous) fermer à clef dans position.**

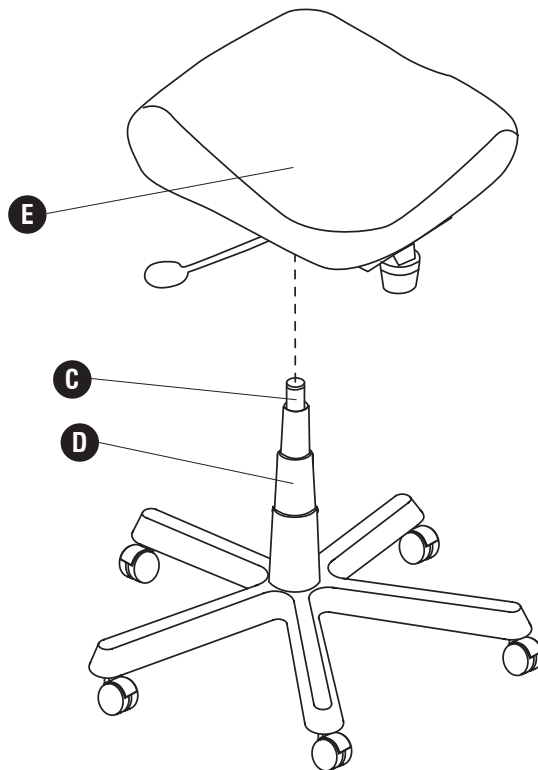



ATTENTION:

Pour les **Directives 4 et 5**, temporairement attachez les boulons de la chaise "doigt-serré," ne serrez pas complètement les boulons jusqu'à tous les verrous sont inséré correctement. Alors, revenez et serrez chaque boulon en utilisant un tournevis.

NOTE: Les Supports sur les Bras seront sur l'intérieur de la chaise, comme montré.

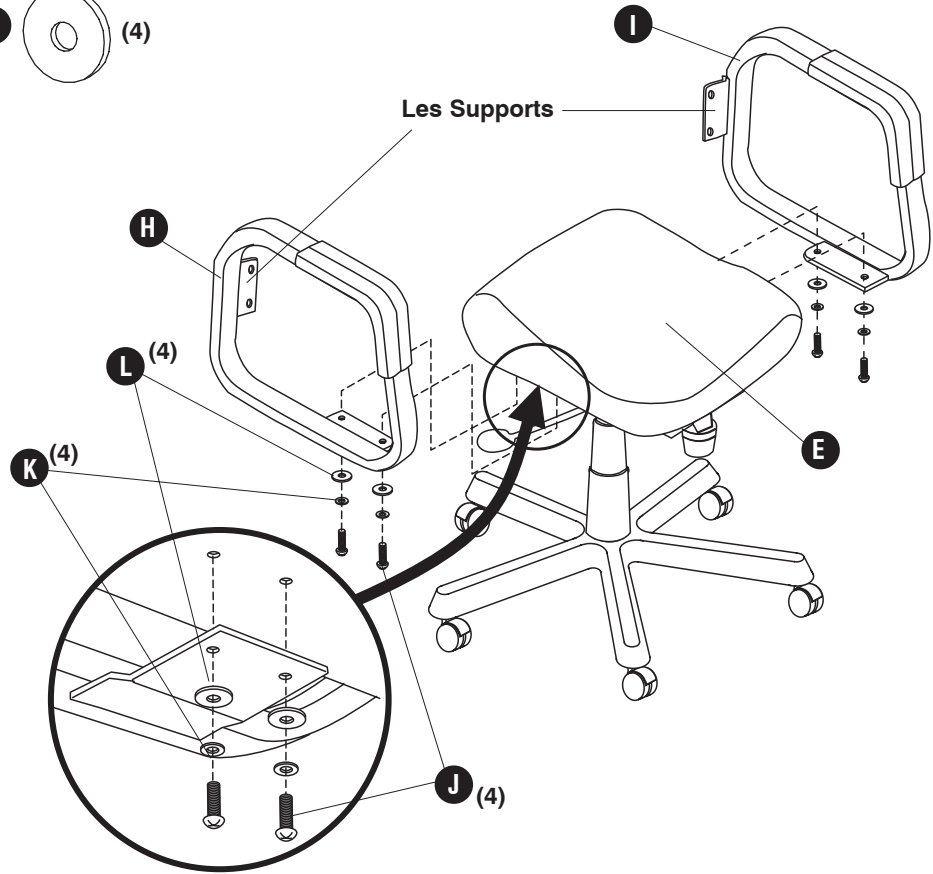

N'attachez pas le Carter pour le Dossier-lit jusqu'à **Directive 6**.

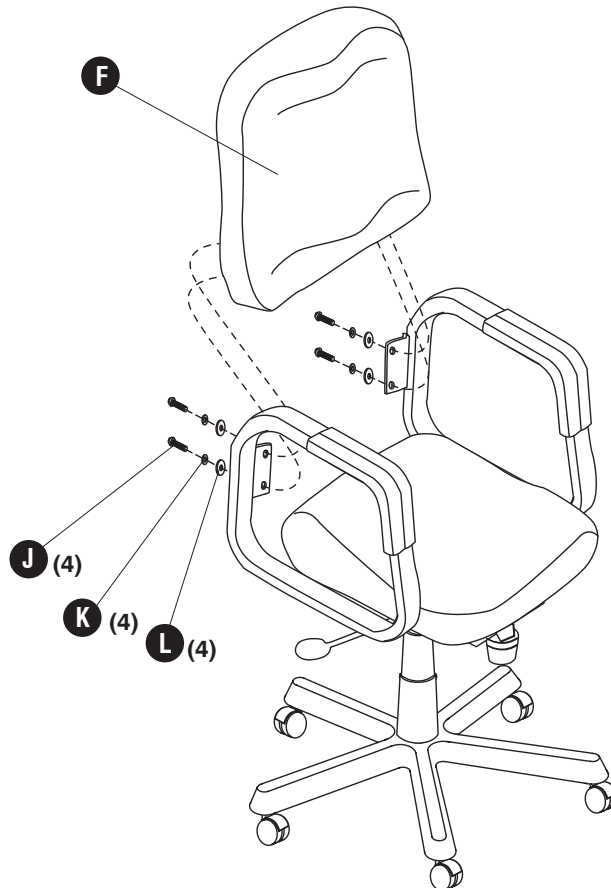
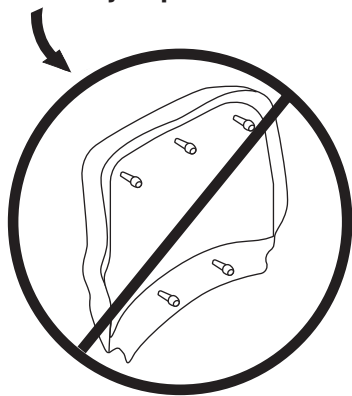

6 **IMPORTANT:** Suivez la séquence de l'installation au-dessous.

Installer le Carter pour le Mi Dossier-lit

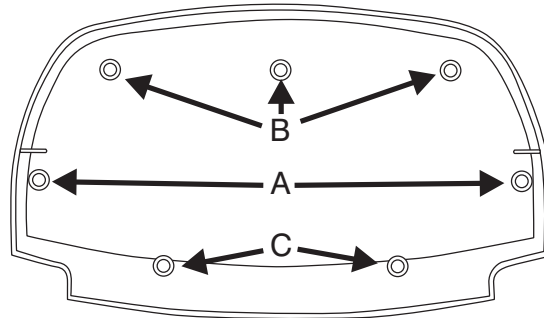
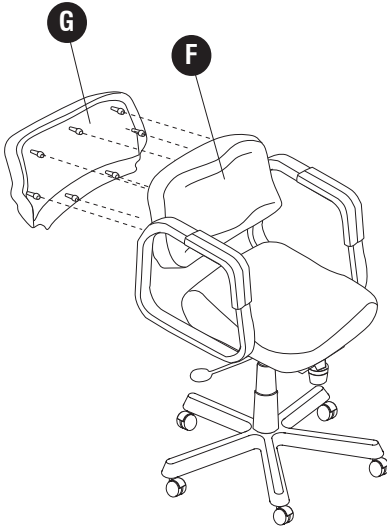

1. Premièrement, pressez **A** dans.
2. Deuxièmement, pressez **B** dans.
3. Troisièmement, pressez **C** dans.

Installer le Carter pour le Haut Dossier-lit

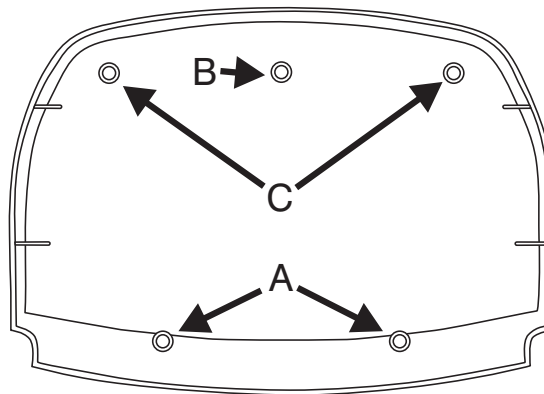
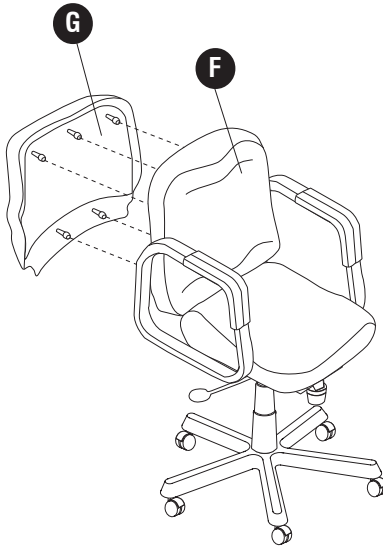

1. Premièrement, pressez **A** dans.
2. Deuxièmement, pressez **B** dans.
3. Troisièmement, pressez **C** dans.

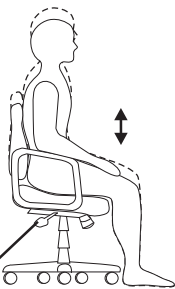

Levier pour l'Ajustement de la Hauteur

1. Ajustement de la Hauteur:

- Asseyez-vous au fond de la chaise et placez vos pieds plat par terre.
- Soulevez le levier et ajustez la hauteur donc vous ne sentez pas de pression sous le dos devant cuisses.

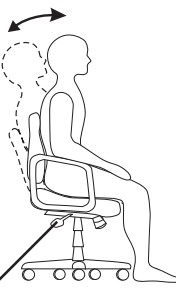

Levier pour l'Ajustement de la Hauteur

2. Contrôle de la Serrure Vertical:

- Enfermez la chaise dans une position verticale et prévenez le balancement en poussant le levier de l'ajustement de la hauteur sous le siège dans le mécanisme du siège.
- Déclenchez la fonction de la serrure en arrachant le levier.

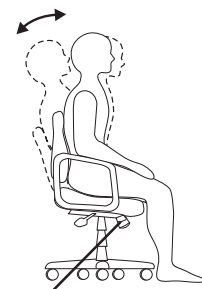

Bouton pour l'Ajustement de l'Inclinaison

3. Ajustez Flexibilité de l'Inclinaison:

- Ajustez la flexibilité du siège en tournant le bouton de l'ajustement de l'inclinaison devant à droite ou gauche comme désiré.

an LDI Company
New Hope, MN 55428
Por favor visítenos en la Internet:
www.safcoproducts.com

INSTRUCCIONES DE ENSAMBLAJE

LEA ESTAS INSTRUCCIONES ANTES DE EMPEZAR. SIGA CUIDA DOSAMENTE LOS PROCEDIMIENTOS POR ENSAMBLAJE.

El formulario de Registro de Garantía de Productos está disponible a: www.safcoproducts.com

HERRAMIENTAS REQUERIDAS: Destornillador Phillips® (Se recomienda dos personas para el ensablaje.)

Por favor lea estas Instrucciones antes de empezar. Siga cuidadosamente los procedimientos por ensamblaje.

LISTA DE PIEZAS			
CÓDIGO	DESCRIPCIÓN	CANTIDAD	NO. DE PIEZA
A	Base	1	3450-02
B	Ruedas	5	3400-75
C	Cilindro Neumático	1	5102-11
D	Guardapolvo del Cilindro	1	3450-14
E	Asamblea del Asiento	1	
	Tejido		3450-01§
	Vinilo		3445-01BL
F	Cojín del Respaldo	1	
	Respaldo Alto - Tejido		3450-03§
	Respaldo Alto - Vinilo		3445-03BL
	Medio Respaldo - Tejido		3451-03§
	Medio Respaldo - Vinilo		3446-03BL
G	Tapa para el Respaldo	1	
	Tapa para el Respaldo Alto		3450-04
	Tapa para el Medio Respaldo		3451-04
H	Asamblea del Brazo Izquierda	1	3450-05
I	Asamblea del Brazo Derecha	1	3450-06

§ Note: Al corresponder sobre las piezas, esté seguro declarar el color: Burdeos (BG), Negro (BL), Azul (BU), Carbón (CH), Negro Guijarro (CB), Azul Guijarro (CL) o Ciruela Guijarro (CP).

PAQUETE MATERIAL 3450-19		
J		K
Tornillo de la Silla CANT.: 8 #3450-22	Arendela Pequeña CANT.: 8 #3450-23	L
		Arendela Grande CANT.: 8 #3450-24

ATENCIÓN:

¡Por favor no ate la Tapa para el Respaldo **G** hacia el Cojín para el Respaldo **F** hasta la **Instrucción 6!** El Cojín para el Respaldo debe atarse a las Asambleas para el Brazo antes de que usted pueda poner la Tapa para el Respaldo en el Cojín para el Respaldo!

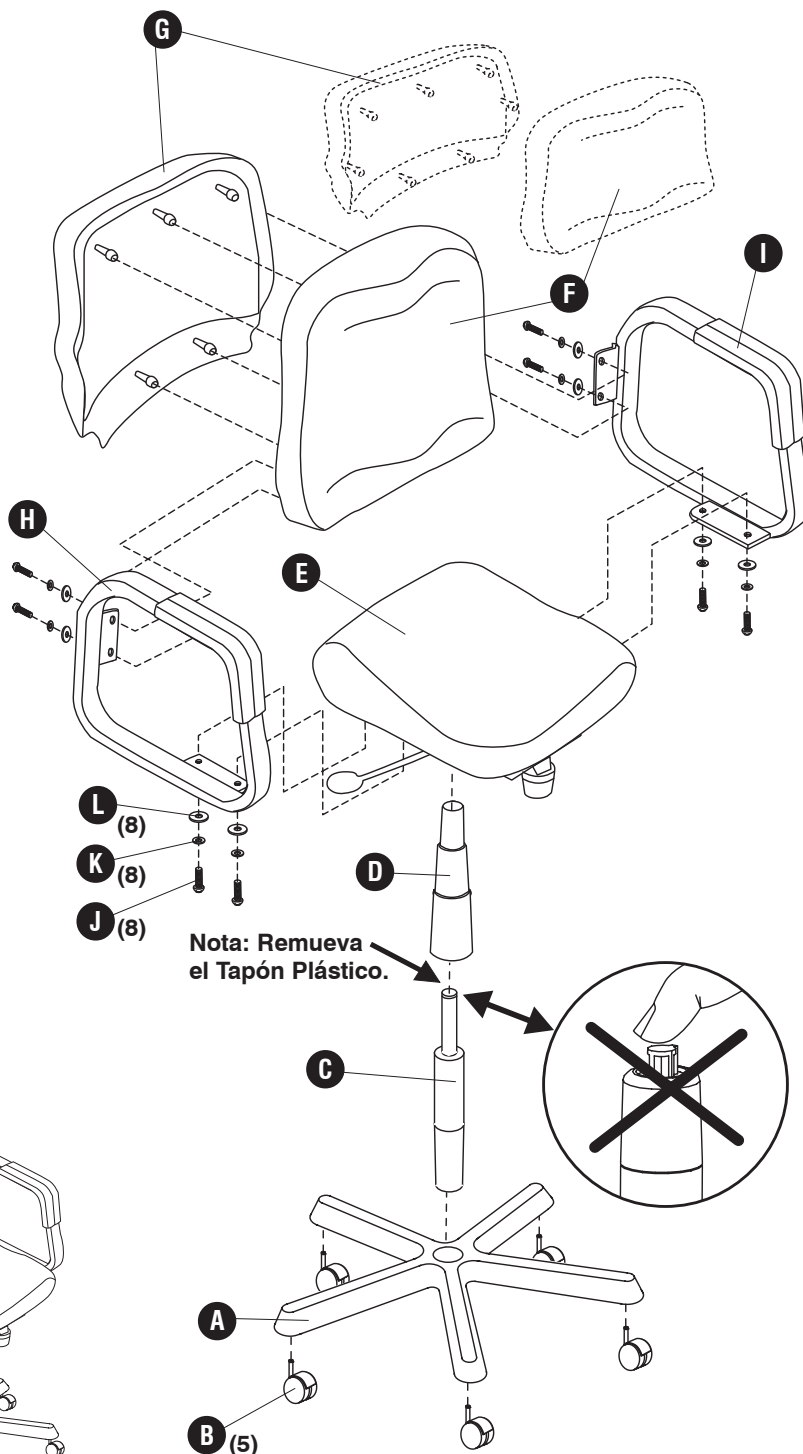
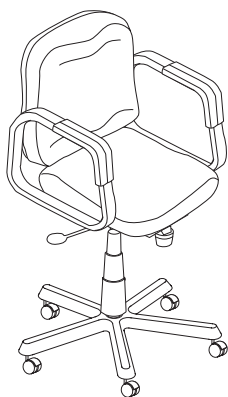

1

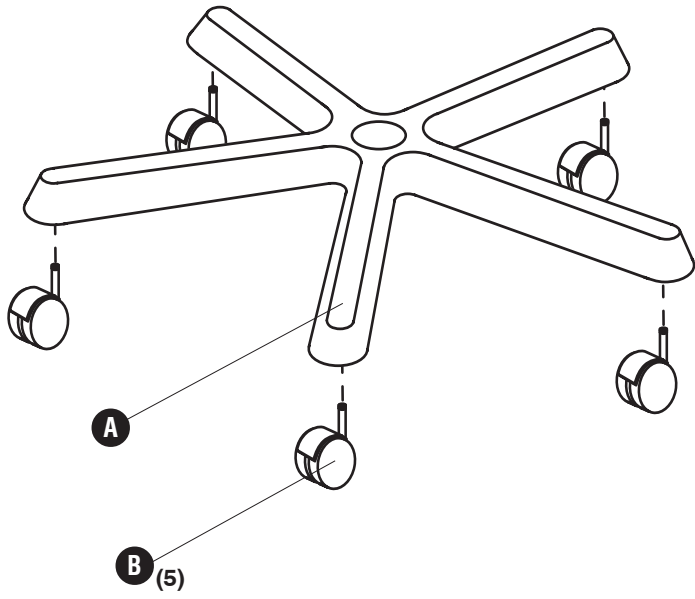

2

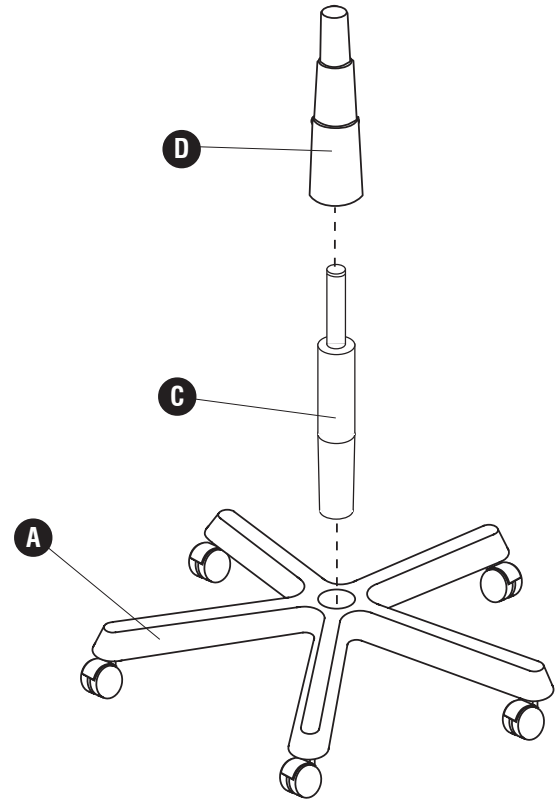

3 Firmemente apriete abajo el asiento (o se sienta en el asiento) para cerrar el asiento en la posición.

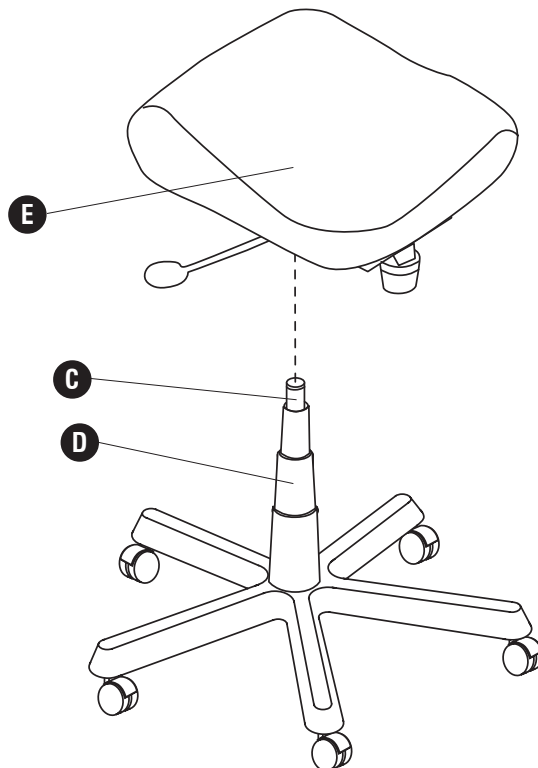



ATENCIÓN:

Para las **Instrucciones 4 y 5**, temporalmente ate los tornillos “dedo-firme,” no aprete los tornillos totalmente hasta todos los tornillos se inserta propiamente. Entonces, remóntese y aprete cada tornillo usando un destornillador.

NOTA: Las Abrazaderas de Montaje en los Brazos estarán en el interior de la silla, como mostrado.

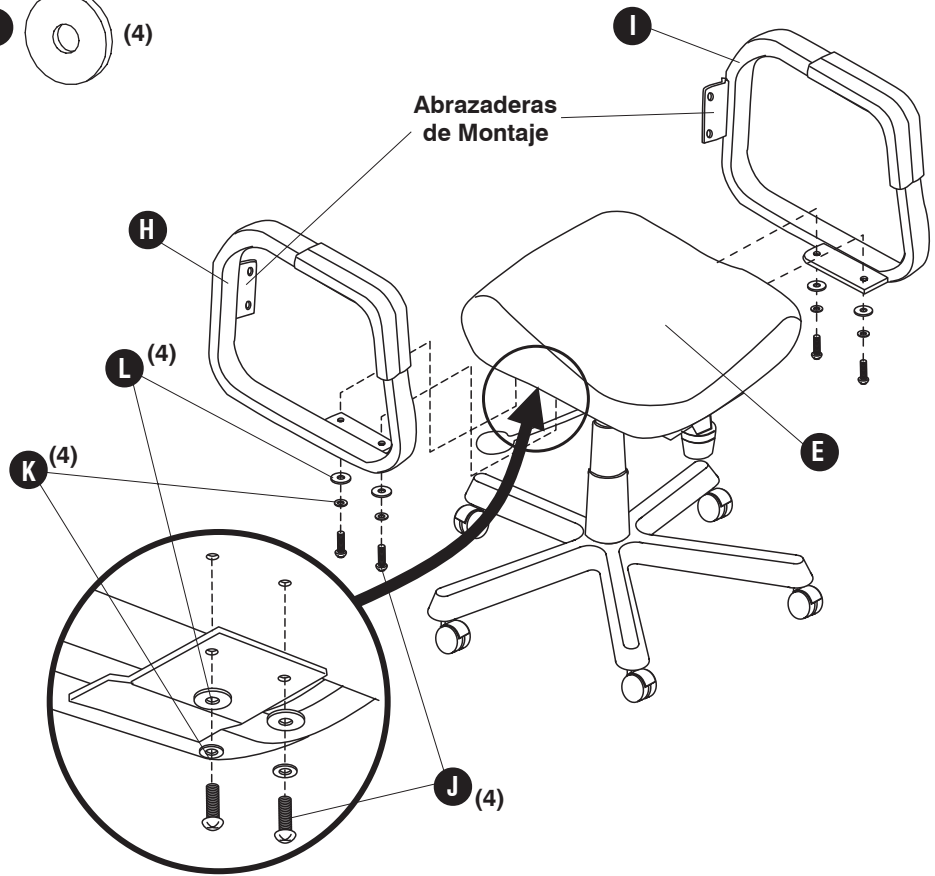

No ate la Tapa para el Respaldo hasta la **Instrucción 6**.

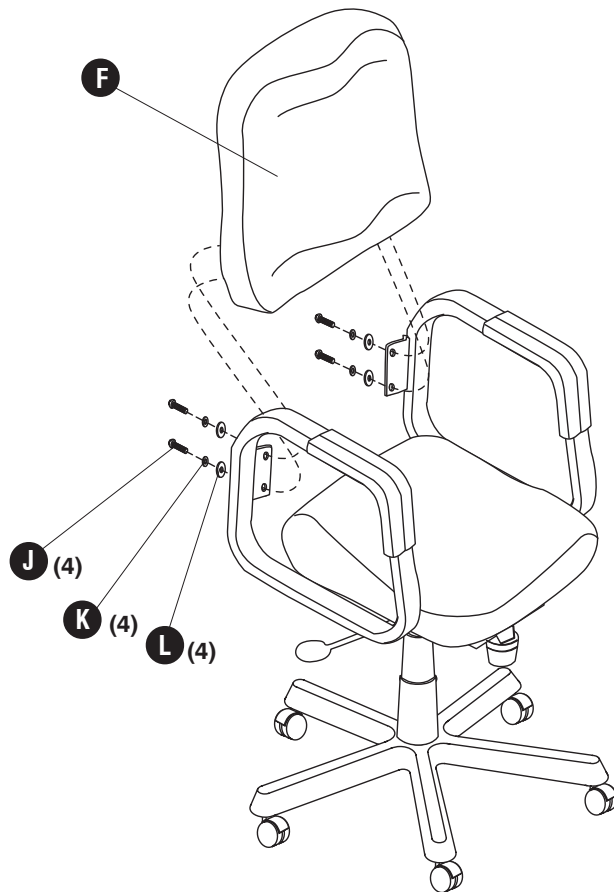
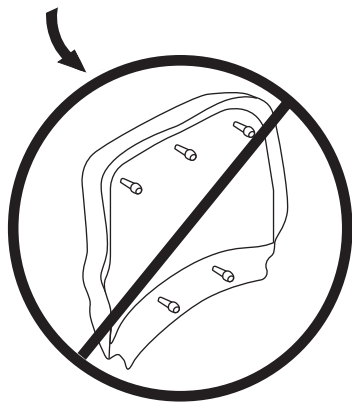

6

IMPORTANTE: Siga estas instrucciones de montaje en el orden cuando ellos aparecen.

Para Instalar la Tapa para el Medio Respaldo

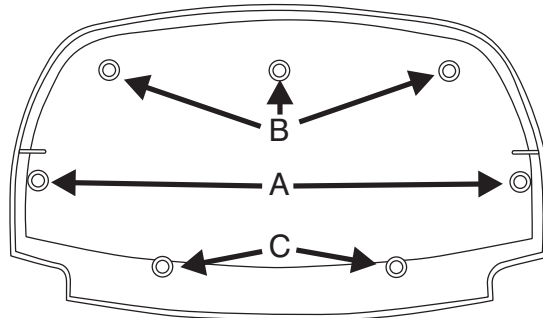
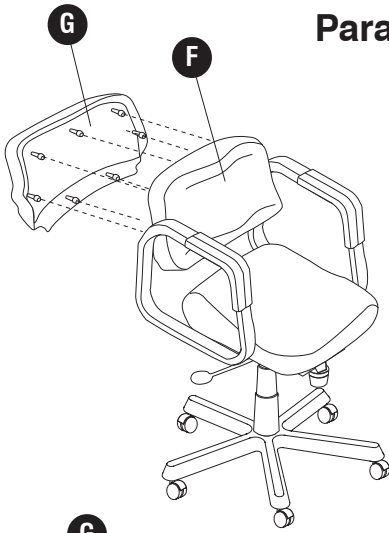

1. Primero, apriete en **A**.
2. Segundo, apriete en **B**.
3. Tercero, apriete en **C**.

Para Instalar la Tapa para el Respaldo Alto

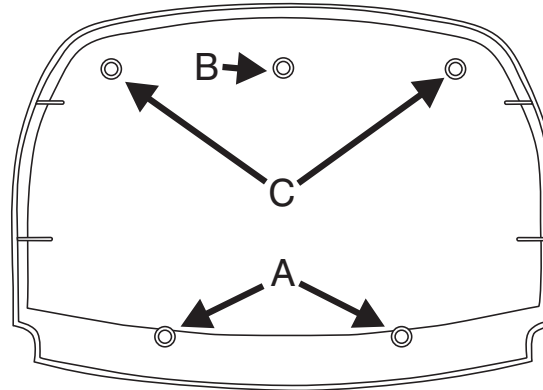

1. Primero, apriete en **A**.
2. Segundo, apriete en **B**.
3. Tercero, apriete en **C**.

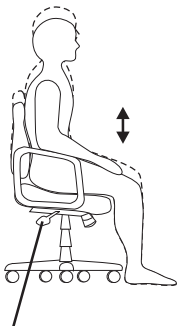

La Palanca de Ajuste de Altura

1. Ajuste de la Altura:

- Siéntese profundamente en la silla y ponga sus pies plano en el suelo.
- Eleve la palanca y ajuste la altura para que usted no siente la presión bajo sus muslos.

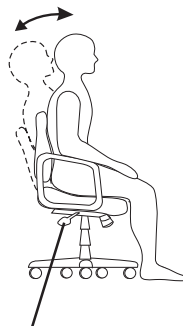

La Palanca de Ajuste de Altura

2. Control de la Cerradura Vertical:

- Cierre la silla en una posición vertical y prevenga meciendo empujando la palanca de la regulación de altura bajo el asiento en el mecanismo del asiento.
- Suelte el rasgo de la cerradura arrancando la palanca.

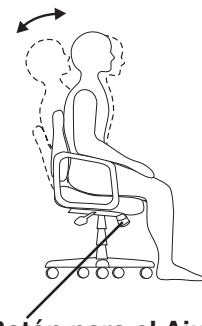

El Botón para el Ajuste de la Inclinación

3. Ajuste la Flexibilidad de Inclinación:

- Ajuste la flexibilidad del asiento volviéndose el botón de ajuste de inclinación delante al derecho o izquierdo como deseado.