

MIDDLE-BACK LEATHER CHAIR

ITEM#: VL642

PARTS LIST

PART#	DESCRIPTION	QTY
A	BACK CUSHION	1PC
B	SEAT CUSHION	1PC
C	ARMREST	1SET
D	SEAT PLATE	1PC
E	GAS LIFT	1PC
F	TELESCOPIC COVER	1PC
G	NYLON BASE	1PC
H	CASTER	5PCS
K	SCREWS(1")	12PCS
L	WASHERS	4PCS
N	PLASTIC CAPS	8PCS
M	ALLEN WRENCH	1PC

ATTENTION:
 Make certain that all screws are fully tightened before using the chair.

1 START

TURN BASE "G" UPSIDE DOWN. PRESS CASTERS "H" INTO HOLES OF EACH LEG OF THE BASE "G".

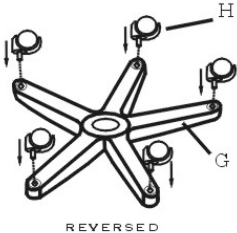

REVERSED

2

INSERT GAS LIFT "E" WITH COVER "F" INTO HOLE IN BASE "G".

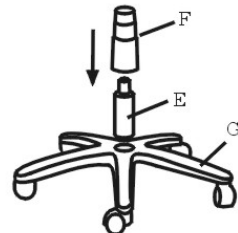

3

FASTEN SEAT PLATE "D" ONTO BOTTOM SIDE OF SEAT CUSHION "B" USING SCREWS "K" AND WASHERS "L".

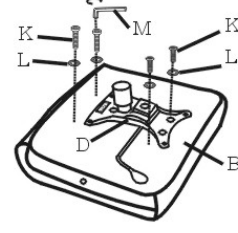

4

ATTACH ARMRESTS "C" TO SEAT CUSHION "B" AND BACK CUSHION "A" USING SCREWS "K". THEN COVER ARMREST HOLES WITH PLASTIC CAPS "N".

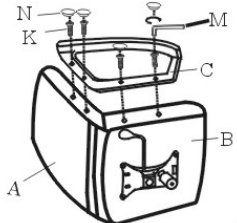

5

THE SAME WITH STEP 4.

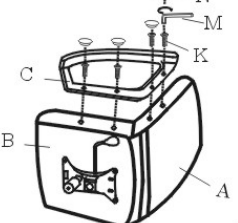

6 COMPLETED

PLACE SEAT ASSEMBLY ONTO GAS LIFT "E". PUSH FIRMLY ON THE CHAIR SEAT TO SECURELY ATTACH SEAT MOUNT TO GAS LIFT.

