

THE FORCE/2

Table of Contents

Machine Information	2
Contacting Intec	3
Introduction	4
Specifications	5
Overview	6
How the System Works Together	9
Safety First	11
Set-Up and Operation	12
Operational Guidelines	15
Sidewalls & Insulation Material	16
Generators and Extension Cords	18
Maintenance	19
Troubleshooting	25
Mechanical Drawings	29
Electrical Drawings	35
Claims, Damage or Loss	48
Returns	50
Receiving Replacement Parts	51
Warranty	52
Insulation Terms and Values	53

MACHINE INFORMATION

THE FORCE/2

Contacting Intec

Phone support:

Available Monday - Friday, excluding holidays. In the United States and Canada, call (800) 666-1611, 7:00 A.M. to 5:00 P.M. Mountain Time. Ask for technical support and one of our technicians will be glad to help you.

On-site/off-site repair support:

Available Monday to Friday, excluding holidays. In the United States and Canada, call (800) 666-1611, 7:00 A.M. to 5:00 P.M. Mountain time. For the latest repair/service centers across the United States visit our web site, www.inteccorp.com and go to service centers. All service centers are independently owned and operated and are not part of Intec. Consult the nearest service center for the hours of operation and lead time for repair.

Website support:

Visit our web site 24/7 at www.inteccorp.com and go to the specific model your wanting information on, then go to the technical bulletins section. The technical section of the web site is constantly being updated with new information and technical documents. If you cannot find what you are looking for please contact us Monday - Friday, excluding holidays, in the United States and Canada, call (800) 666-1611, 7:00 A.M. to 5:00 P.M. Mountain Time. Ask for technical support and one of our technicians will be glad to help you.

Contact Information:

3771 Monarch Street

Frederick, CO 80530

Ph: 1-303-833-6644

1-800-666-1611

Fax: 1-303-833-6650

E-mail: info@inteccorp.com

THE Force/2 *Insulation Blowing Machine*

Your FORCE/2 insulation blowing machine, the product of years of laboratory and field testing, offers both the contractor and the homeowner exceptional performance, total reliability, and ease of use.

It is designed and built to blow-in more than a ton of material per hour. No other machine in its class can match the performance of the FORCE/2.

Because no insulation goes through the blower, the FORCE/2 is a virtual workhorse, requiring only minimal maintenance. The direct drive feature also means there are no chains for you to adjust or replace, ever.

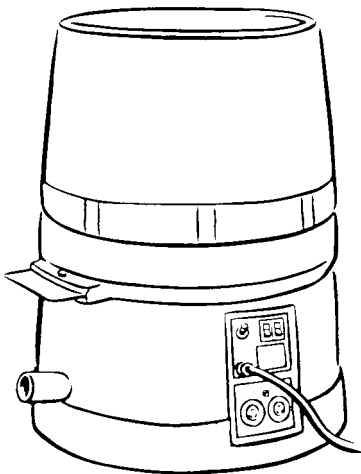

Following the instructions in this manual, setting up and operating the FORCE/2 on the jobsite will be uncomplicated, quick, safe, and easy. Once your work is finished, end-of-the-day clean up is equally efficient.

Exceptional performance. Total reliability. Ease of use. Those are the reasons why the FORCE/2 is your best choice.

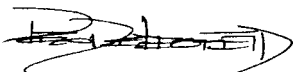

Rex Deitesfield
President

THE FORCE/2

Specifications

Height	45" without wheels 50½" with wheels
Width	32"
Weight	283 lbs. without wheels 302 lbs. with wheels
Hopper Capacity	50 lbs.
Hose Size	3"
Blower, 2-stage	105 CFM, 3.6 PSI (AVG) 11.5 amps 116 CFM, 4.5 PSI (AVG) 12.5 amps (Optional)
Agitator Motor	1-½ hp - 14.5 or 17.2 amps 115 VAC 2 hp - 21 AMPS 115 VAC (Optional)
Gear Box	Custom, direct drive
Airlock	8" x 10" opening, steel, 6-vane, cast urethane seals
Electric	115/220 VAC single phase
Agitator	6-blade
Warranty	One year limited; 90 days limited on electric, blower and airlock system

Specifications are subject to change without notice.

THE FORCE/2

Overview

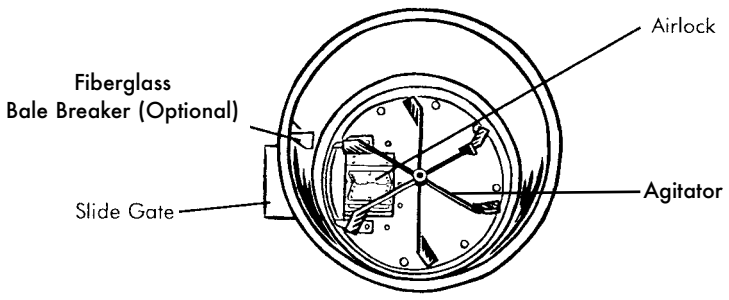
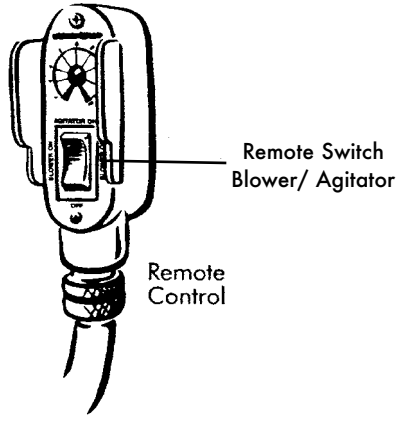
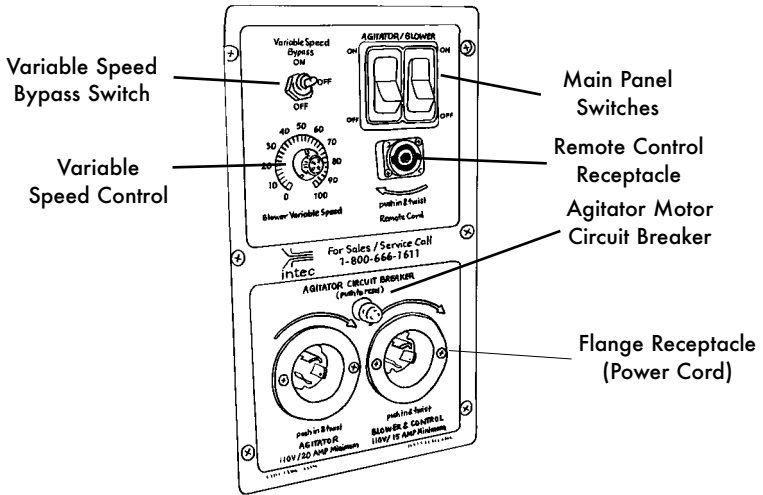

THE FORCE/2

Overview, Cont.

THREE SUBSYSTEMS MAKE UP YOUR FORCE/2:

1. THE AGITATOR AND AIRLOCK. Your FORCE/2 runs on a 1-½ or 2 horsepower motor driving an enclosed gearbox. The gearbox drives both the agitator and airlock components at a constant speed.

2. THE BLOWER MOTOR. Your FORCE/2 is equipped with either a 105 or 116 CFM two-stage blower motor to push the material through the hose and into the attic with optimum pressure and output. The blower is connected to the air intake port of the airlock by a plastic hose.

3. ELECTRICAL COMPONENTS. Your FORCE/2 requires two dedicated 20 amp grounded outlets. A circuit (outlet) rated lower than 20 AMPS may cause premature tripping at the power source.

Always disconnect the power cords before beginning any maintenance. And as with all electrical systems, never attempt to operate your FORCE/2 with either the operator or the machine standing in water.

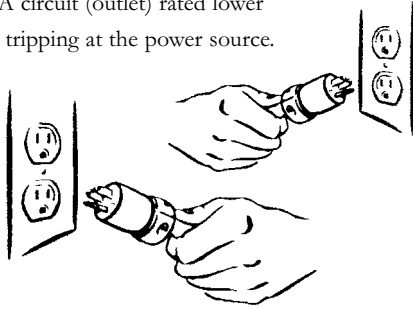

(2) 20 amp outlets

SYSTEM COMPONENTS. (See next page for drawings.)

- A. Hopper: Upper component of the FORCE/2 where insulation is loaded.
- B. Base: Lower component of the FORCE/2 houses power components, agitator motor, blower, gearbox, airlock and electrical system.
- C. Slide gate: Regulates the amount of material entering the airlock.
- D. Electrical: Operates the on/off function of both the blower and agitator motors.
- E. Remote: Allows the control of the on/off function of both the blower and agitator motors via a 100" control cable.

THE FORCE/2

Overview, Cont.

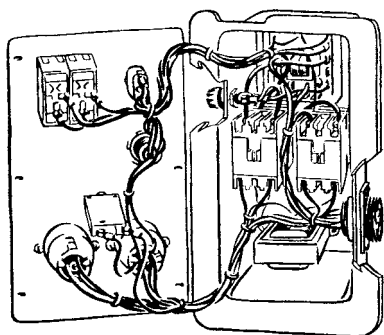
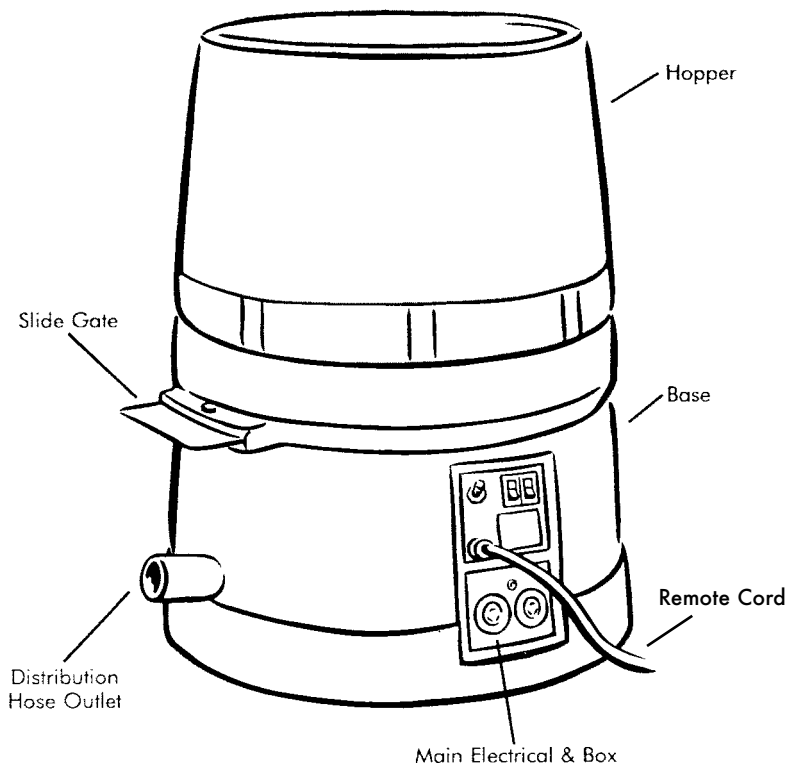

Electrical Box

Example only see page 35 for specific electrical systems.

THE FORCE/2

How the System Works Together

AGITATOR: Conditions the insulation material to an optimum configuration, then sweeps the material into the airlock for distribution through the hose.

AGITATOR MOTOR: Drives the gearbox. No maintenance is required. Produces 1-½ HP @ 14.5 or 17.2 amps, 115 VAC. Optional motor 2 HP @ 21 amps, 115 VAC.

AIRLOCK: Moves the conditioned insulation material from the agitator into the air flow from the blower. Airlock seals must be inspected regularly and kept in good working order for the FORCE/2 to operate efficiently. We recommend changing the airlock seals every 300 hours, 200,000 pounds of insulation or once a year, whichever comes first.

BLOWER: Creates the airflow which propels the material from the airlock into the hose for distribution. No insulation material passes through the blower. The standard blower moves 105 CFM drawing 11.5 amps, 115 VAC or the optional 116 CFM blower draws 12.5 amps at 115 VAC. *See the maintenance section for required service.*

GEARBOX: Operates both the airlock and agitation system, the gearbox requires periodic maintenance, including changing the oil at least once a year. See the maintenance section for more details about changing the gearbox oil. If you are working in cold weather, changing to Mobil 1 or 5W-30 high performance synthetic oil will aid in cold weather start-ups. In addition, inspect the gearbox and airlock alignment regularly. Alignment must be perpendicular to each other, preventing excess wear on the airlock and gearbox shaft connection.

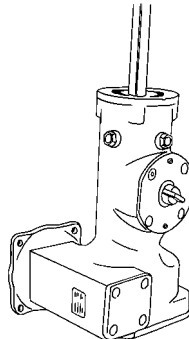
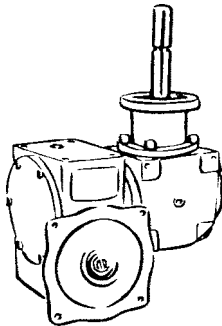

THE FORCE/2

How the System Works Together, Cont.

REMOTE CONTROL:

Permanently attached to the main panel, the remote control cord allows the operator to control the machine's on/off function from the attic. Both the agitator and the blower can be operated independently by the remote control. The blower speed control is built into the remote cord to enable the operator to decrease or increase blower pressure and air volume.

DETACHABLE REMOTE

The remote cord **must be attached** at all times in order for the machine to operate. To connect, locate the keyed positions on both the receptacle (Electrical panel) and connector on remote cord. Insert connector into receptacle and turn clockwise until it clicks in. To lock remote cord into receptacle, turn blue outer ring on remote cord connector and turn clockwise until it stops.



Remote Control with VS Control

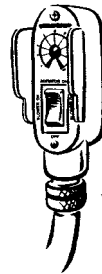

Remote Control with Disconnect

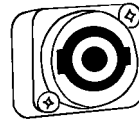

push in & twist
Remote Cord

Align, Push in and Twist

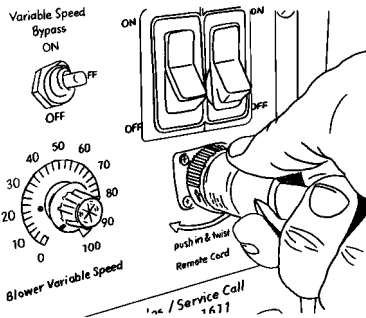

Service Call 1-671

Turn outer Ring

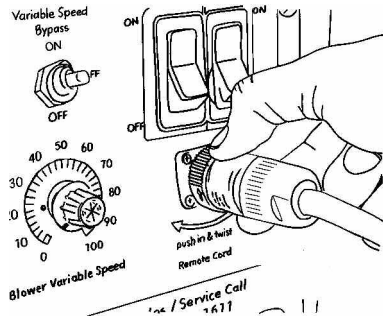

Service Call 1-671

THE FORCE/2

Safety First

When working with insulation, always wear a long sleeve shirt, gloves, a hat, goggles or safety glasses for eye protection and a 3M brand #8710 nose/mouth filter (or equivalent) for respiratory protection.

ACCESSORIES YOU NEED TO WEAR...

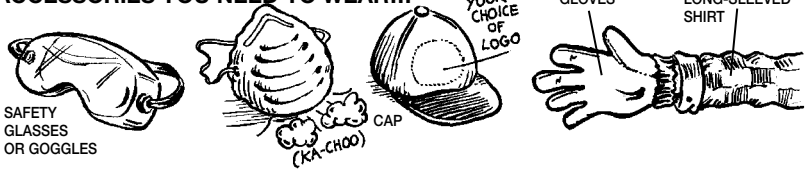

Never put your hands into the hopper while the machine is running.

Keep tools and other foreign objects out of the hopper. Clean all material out of the hopper and the hose when your job is complete.

Never leave your machine unattended while it is running. Turn "off" and disconnect power before taking a break.

Never operate your machine if it or the operator is standing in water. Serious injury may result.



THE FORCE/2

Set-Up and Operation

ELECTRICAL CONNECTIONS: Before connecting the machine to electrical power, make sure all switches are in the "off " position. Connect both supplied extension cords to dedicated 115V 20 amp grounded outlets. In the home, refrigerator or freezer outlets usually fit the amperage requirements. If necessary, these appliances can be temporarily unplugged, enabling the

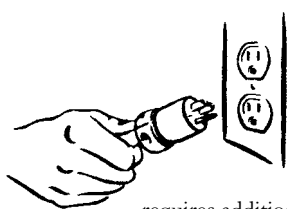

FORCE/2 to use the outlet. Disconnecting these appliances for the short time needed to operate the FORCE/2 will not cause spoilage. Remember to reconnect any unplugged appliance after the job is finished. If your job requires additional extension cords, make sure you use only a 10/3 cord for a 50 foot run or 8/3 cord for a 100 foot extension.

STARTING:

Operation from the Attic: To use the remote control feature for attic operation, the switches on the main electrical panel must be in the "on" position. Control the machine using the rocker switch on the remote cord.

Operation from the Ground: To operate the FORCE/2 from the ground, the rocker switch on the remote control must be in the "on" position. Operate the blower and agitator from the main electrical panel toggle switches. **Note:** In cold weather, your machine is more difficult to start. If possible, store your FORCE/2 in a warm area over-night before starting this

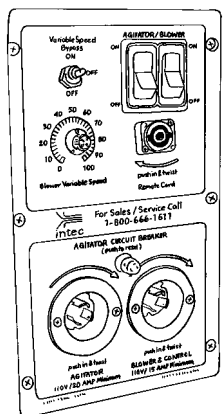

helps ensure the lubricant (oil) is warm, enabling the bearings and gearbox to turn freely.

THE FORCE/2

Set-Up and Operation, Cont.

HOSE SETUP, ATTIC:

Cellulose: For normal attic applications, use a minimum of 100 feet of 3 inch hose on your job. Longer hose length decreases both capacity and material throw. Using 200 feet of hose, capacity and throw will be reduced by approximately 30%. If you must use a hose longer than 150 feet, reduce the hose size to 2-½ inch diameter for the last 50'.

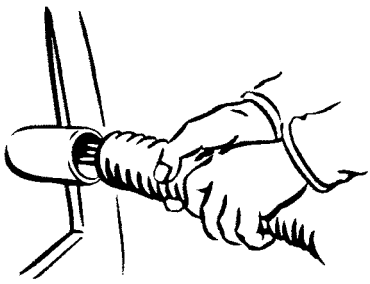

Distribution Hose

Fiberglass: Use a minimum of 150 feet of hose. Use 100 feet of 3" hose and a 50 foot section of 2-1/2" hose using a 3 x 2-1/2" steel hose reducer. This hose configuration aids in the opening of the fiber and increases the throw of the material.

Example of Hose Connections:

HOPPER SAFETY: Your safety is the most important consideration

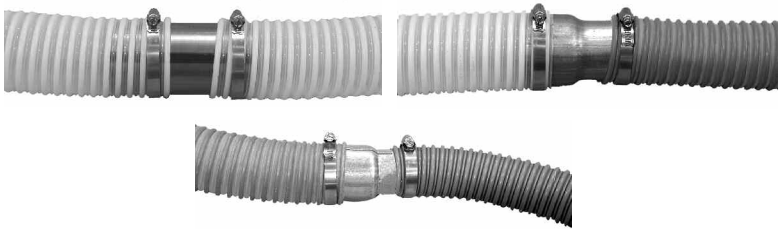

whenever you are using any machine. Following the instructions in this manual along with good common sense, should allow you to complete your job in a safe and efficient manner. First, before loading your FORCE/2, follow all safety considerations provided by the manufacturer of the insulation material you are using, including wearing protective masks or respirators. Never wear loose clothing or other items while running this machine. Failure to follow safety precautions may result in permanent injury.

Any time you overload the hopper or place objects other than insulation material into the hopper, you are risking personal injury or equipment breakdown.

THE FORCE/2

Set-Up and Operation, Cont.

LOADING THE HOPPER: Machine may be “on or off” while loading. **Cellulose**, place the bag of insulation material on the hopper. Use a knife to open the bag so that the material falls into the hopper. Your FORCE/2 is designed to self-feed. **Fiberglass**, place the bag on the side of the hopper. Cut the bag in thirds and dispense one third of the contents gradually until the agitator breaks up and conditions the material. Load the remainder of the material according to the distribution rate. Empty no more than $\frac{1}{3}$ bag at a time into the hopper, waiting until at least $\frac{1}{4}$ of the material has been used before adding additional insulation. **Forcing insulation material will cause overloading, electrical failure or possible machine damage.**

If the agitator stops or the circuit breaker on the electrical panel trips, unplug the machine from electrical power. Remove the cause of the jam from the hopper. You may have to empty all the insulation material to locate and remove the jam. After clearing, reset the circuit breaker, reconnect power and continue normal operation. *See page 22 for more information on unjamming.*

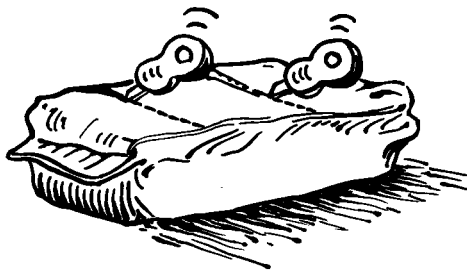

Fiberglass Insulation Only: Cut as shown and break bag into three sections

THE FORCE/2

Operational Guidelines

BLOWING SIDEWALLS, CELLULOSE:

When blowing sidewalls, use the following settings and recommendations as guidelines. Settings may change from job to job, material to material, or nozzle to nozzle. Hose length and humidity may affect your results.

Two hole method, standard wall construction: 2" x 4" x 16" on center.

Hole size	Slide gate opening	Air Setting
2"	2"	100%
1"	1½"	100%
5/8"	1"	100%

Keeping the material level consistent in the hopper will aid in achieving good sidewall densities. A gradual transition in hose size will aid in the material flow and help eliminate clogging. At the machine, start with 50' of 3" hose, connect 50' of 2-½" next and then connect 50' of 2". Use hose reducers and clamps to connect the hose making sure all connections are tight *see page 13 for examples of hose set-up*. If clogging or less than satisfactory compaction occurs, adjust the slide gate inward by ½" increments until the situation clears. If the problem persists, add an additional 50' of 2" hose and readjust the slide gate setting, maximum hose length, 200 feet.

BLOWING WALLS:

Drill two holes into the wall, one 17" from the bottom and one 17" from the top of the cavity. Always use the largest hole possible to prevent clogging. Starting with the bottom hole, put the insulation nozzle into the hole, using the remote, turn the blower on first, then the agitator. Fill the cavity until the material stops flowing, turn off the agitator and allow the blower to push additional material into the wall. Turn off the blower and wait a few seconds before removing the insulation nozzle. Repeat the steps for filling the cavity through the top hole.

THE FORCE/2

Sidewalls & Insulation Material

Construction example: 2 inches x 4 inches x 8 feet on 16 inch centers, 2.8 cubic foot cavity

CELLULOSE COVERAGE:

1.6 pound material density, 18.7 pound bag

Wall Pack Density	Pounds Per Cavity
4.0 pounds	11.2 pounds
3.5 pounds	9.8 pounds
3.0 pounds	8.4 pounds

Average yield with Cellulose: 1.9 cavities per 18.7 pound bag

FIBERGLASS COVERAGE:

JM Product Information: (800) 654-3103

Johns Manville Climate Pro, 27 pound bag

Wall Pack Density	Pounds Per Cavity
1.70 pounds	4.65 pounds

Average yield with Climate Pro: 5.8 cavities per 27 pound bag

CertainTeed Technical Services: (800) 233-8990

CertainTeed InsulSafe 4, 28.5 pound bag

Wall Pack Density	Pounds Per Cavity
1.60 pounds	4.20 pounds

Average yield with InsulSafe 4: 6.8 cavities per 28.5 pound bag

These examples are guidelines only. Consult individual manufacturers for specific information.

FIBERGLASS WET SPRAY COVERAGE

Guardian Fiberglass Product information: (800) 748-0035

Guardian UltraFit DS 30 pound bag

Wall Pack Density	Pounds Per Cavity
2-½ pounds	7.05 pounds

Average yield per bag, 4-1/4 cavities per 30 pound bag

Use a minimum of 100' of hose for proper conditioning.

THE FORCE/2

Sidewalls & Insulation Material

FIGURING WALL CAVITY AREA

Measure wall cavity in inches. Multiply depth x width x height. Example:

(1) 3½" deep x 14½" wide x 92½" tall = 4,700 cubic inches

(2) Divide 4,700 by 1,728 = 2.72 cubic feet in the cavity.

Each wall cavity may vary slightly.

(1,728 equals the number of cubic inches in a cubic foot.)

Actual pre-cut lumber dimensions:

2 x 4 x 8: 1½ inches x 3½ inches x 92½ inches

2 x 6 x 8: 1½ inches x 5½ inches x 92½ inches

CELLULOSE WET SPRAY

Your Force/2 can apply both wall-spray and spray-on materials. There are many different types of material for these applications and depending upon the material your results will differ. The Force/2 has been designed to apply most materials and can recycle up 75/25 blend of Dry/Wet cellulose material. Using recycled material will change the speed of the material traveling through the hose and will change the impact (density) of the wall area being sprayed. It is recommended that you test a small area of wall section to determine optimum machine settings before starting the job. Loading of the hopper can affect the desired wall-spray job, we recommend that when loading the hopper **do not dispense wet material into an empty hopper!**, doing so may clog hose! Dispense wet material on top of dry material and allow the agitator to blend the materials. Hose length, nozzle orifice size and design play a key role to a successful application. The nozzle you select will determine how to set up the machine. **General guideline for setting your machine;** 100 feet of 2 or 2-1/2" hose, variable speed setting of 80-100% with the slide gate 1/4-1/3 open. When using 2 or 2-1/2" hose we recommend using an insert tube to enhance setup and reduce the likely hood of clogging the hose. For further information on Cellulose Wall-Spray or Spray-On consult Intec or your local supplier of insulation material.

THE FORCE/2 *Generators and Extension Cords*

Your FORCE/2 will operate on power from a commercial-sized generator. No household generators may be used due to the high inrush requirements of the FORCE/2. **Also, generators made by Honda, Yamaha, Coleman and Generac are not recommended.** While they are of high quality, these generators do not have the inrush protection devices necessary to start the FORCE/2 and protect the generator. The start-up requirement for a FORCE/2 is 9660 watts; normal operating requirement is 3300 watts. **We recommend a generator of not less than 9000 watts, 120 VAC.** In addition, Intec recommends generators that have a 50% power boost feature which aids the generator in high current startups.

Running additional equipment from the same generator means you will need to know the total electrical requirements before selecting the correct size of generator. For details on selecting and purchasing a generator, please call INTEC.

Note: Using a generator of insufficient size will void your Warranty.

Adding Additional Power Cords.

Cord Current Capacities, Type S & SVT

Wire Size AWG	3 Conductor Amps	4 Conductor Amps
10	25	20
12	20	15
14	15	12
16	10	8
18	7	6

The length of cord and ambient temperature does have an effect on the electrical current capacity. Consult Intec for your specific needs or your local electrical distributor.

THE FORCE/2

Maintenance

Reasonable preventive maintenance will help ensure your FORCE/2 gives you many years of satisfactory use. Cleaning the interior and exterior of your machine and protecting its finish with a product such as Armor All will keep it looking new.

CORDS AND SWITCHES

The remote cord and switches are subject to considerable wear and tear during normal use. Inspect all cords and switches each week for cuts or loose connections. Repair or replace any damaged components at once to avoid possible injury.

AIRLOCK BLOW BACK

Airlock seals are the most important component of keeping your FORCE/2 running in original condition. Airlock seals function much like the rings in a car engine, keeping pressure and air from escaping. When a seal or plate is damaged, air from the blower will escape back into the hopper causing "blow back." Blow back will result in a considerable decrease in production.

Checking for blow back; unplug the machine from electrical power and empty all insulation material from the hopper. Block the hose outlet with duct tape, or use the palm of your hand. Reconnect the power and turn on both the blower and agitator motor. A hissing or puffing sound of air escaping into the hopper indicates blow back.

In addition, any insulation material remaining in the airlock will blow back into the hopper, creating dust. To remedy blow back, it is necessary to replace the airlock seals or plates.

Note: Your FORCE/2 comes from the factory preset to produce 3.2-4.8 PSI. You may purchase a pressure gauge from Intec to aid in determining the pressure developed by the blower and airlock, system.

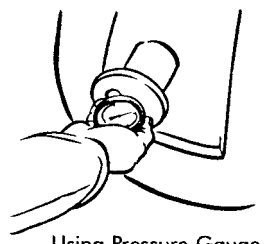

Using Pressure Gauge

THE FORCE/2

Maintenance, Cont.

REPLACING AIRLOCK SEALS

We recommend changing the airlock seals every 300 hours, 200,000 pounds of insulation or once a year, whichever comes first.

Unplug the FORCE/2 from electrical power and empty all insulation material from the hopper. Seal replacement requires a 7/16" socket and ratchet, a 6" socket extension and a 7/16" open-end wrench. With the machine in an upright position, locate the seven 1/4*20 bolts holding the seal in place. Loosen and remove the fasteners. Remove the damaged seal from the rotor shaft. Reverse the process to install a new seal. Be careful that the direction of the seal is correct. Seal must be equally wrapped around both sides and seated all the way down on the rotor shaft! Snug down the bolts. **Do not overtighten.** Overtightening will cause the seal to bow out at the ends producing uneven wear and premature failure. To replace other damaged seals, reconnect electrical power and, using the remote switch, move the airlock seal into the position for removal. Again, disconnect from electrical power before doing the actual repair or replacement. **Note:** Do not install the seals backwards. *See pages 32 and 33 for additional illustrations.*

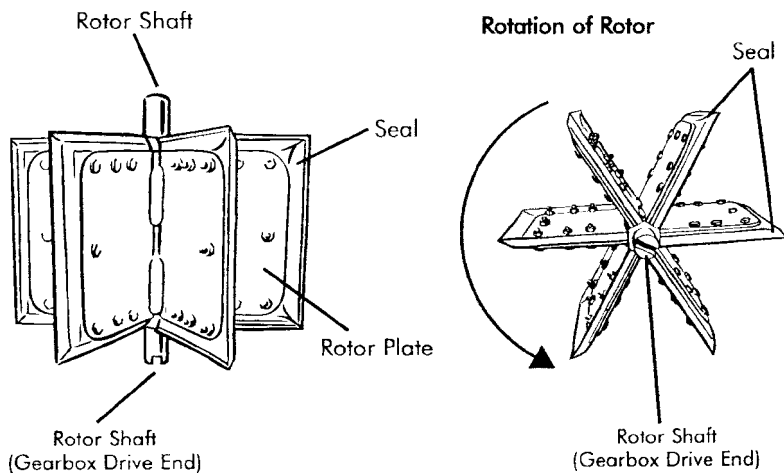

THE FORCE/2

Maintenance, Cont.

GEARBOX

The oil in the gearbox of your FORCE/2 should be changed every year to ensure proper lubrication of the gears and seals.

Changing oil in all direct drive models:

Model 22015

Place the machine on its side with clear access to the two drain/fill plugs on the gearbox. Place a drain pan under each plug to catch the used oil. Remove the drain plug from each of the two gearbox chambers with a 90° 3/8 inch hex wrench. Drain the oil into the pans. To refill, pour four ounces of oil into a six ounce disposable paper cup. Bend cup lip to form a pouring spout. Pour a total of 20 ounces into worm gear case and 16 ounces into bevel gear case, and reinstall plugs using the hex wrench. Note: At cold temperatures, oil thickens, slowing the draining process. Leave your machine in a warm area overnight (eight hours) to make oil changing easier. See illustration for the location of the drain/fill plugs.

Model 22015

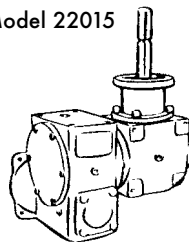

Recommended gearbox oil:

Model 22015 (Mfg. from 7/89 - 11/02)

Temperature 40° - 100° F Mobil SHC 634 gear lube

Temperatures -20° - +40° F Mobil 1 synthetic 5W-30

Worm gear case capacity 20 oz.

Bevel gear case capacity 16 oz.

Model 22014 (Mfg. from 8/02 - present)

Lay machine on its side with clear access to the bottom drain plug. Place drain pan under drain plug and remove using a 5/16 hex wrench. Drain oil into pan, tip machine upright to drain remainder of oil in gearbox housing, close vent plug. Pour 48 ounces into worm gear case and re-install drain plug. Tip machine on side and open vent plug 1/4- 1/2 turn by hand. **Note:** In cold temperatures the oil thickens slowing the draining process. Leave the machine in a warm area overnight (eight hours) to make oil changing easier. See illustration for location of vent and drain plugs (page 22).

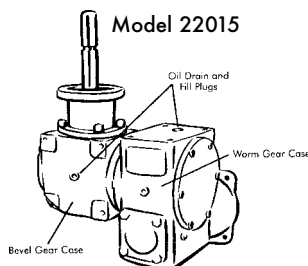

Model 22014

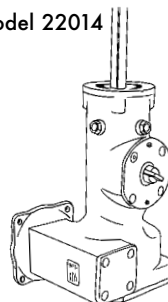

08/2002

THE FORCE/2

Maintenance, Cont.

Recommended gearbox oil:

Model 22014

Capacity: 48 oz.

Temperature 40° - 100° F Mobil SHC 634 gear lube

Temperatures -20° - +40° F Mobil 1 synthetic 5W-30

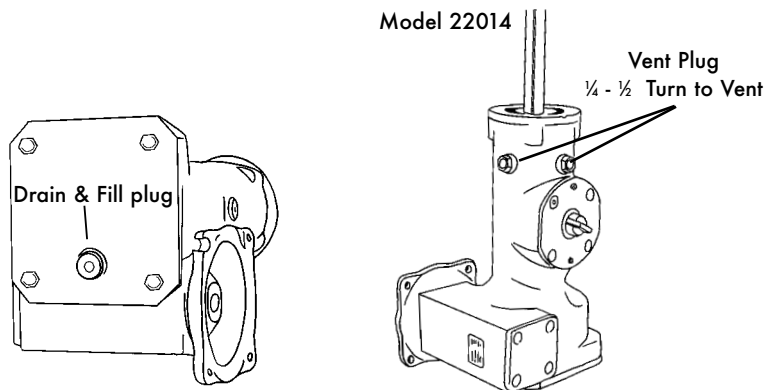

Gearbox/Agitator/Airlock Unjamming procedure: Empty hopper, disconnect all electrical cords to machine. Tip machine upside down onto hopper. Remove agitator motor cover on outside of machine (black plastic). Locate and remove fan cover on agitator motor. **Note:** Depending upon the motor used it will be necessary to remove the screws holding the fan cover on before removal, otherwise all other covers may be pried off using screwdriver. By hand, carefully turn fan blade counter-clockwise until jam is cleared. **Note:** It will take approximately 15 turns of the fan blade before you start to reverse the entire airlock system. **Caution! Fan blade may break if excessive force is used.**

Note: The gearbox and the airlock must be perpendicular to each other. Proper alignment prevents premature wear on the gearbox and airlock shaft connection.

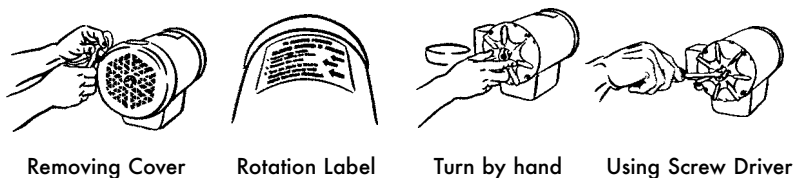

THE FORCE/2

Maintenance, Cont.

BLOWER MAINTENANCE

Keeping the blower as clean as possible will avoid system overheating. Overheating will cause lowered production, possible system failure and shorten the expected life of your FORCE/2. Inspect blower brushes every three months or 100 hours of use. Replace brushes when they reach ¼ inch or less in length. Change the brushes before the brush stunt touches the commutator. When reassembling, the lead wires must be isolated from the motor frame and any rotating parts. For optimum performance, new brushes must be properly seated against the commutator before operating your FORCE/2 at full power.

NOTE: BRUSH INSTALLATION

After installation of new brushes, plug in machine as normal and set blower speed control (variable speed) at 30% of full power, run for ½ hour. Set blower speed control at 70% of full power, run for ½ hour.

CLEANING

Use compressed air to blow out motor and intake of blower every 20-30 hours of use to maximize blower impeller and motor life.

Blower Warranty Considerations. The following blower abuse is not covered by warranty:

- Damage in shipment
- Visible moisture damage such as rust
- Rust or other corrosion on motor exterior
- Dirty motor or insulation buildup in impeller
- Broken components, i.e. brushes, brush holder, etc.
- User modification of blower, holes, etc.
- User rewound armatures or fields
- Evidence of user disassembly
- Evidence of foreign object in fan end of motor

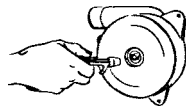

THE FORCE/2

Maintenance, Cont.

REPLACING BLOWER BRUSHES

Model 21025 (105 CFM) *brush replacement not recommended*

Model 21024 (116 CFM) *shown*

Removing old brushes: Disconnect all electrical cords to machine. Tip machine upside down onto hopper. To facilitate replacement of the blower brushes remove blower from machine. Locate brush clips (fig 1), using flat

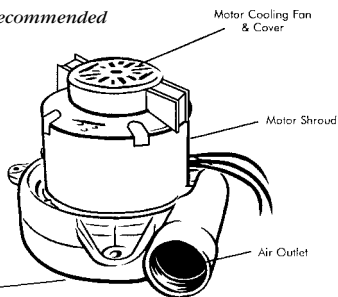

screwdriver place screwdriver under brush clip as shown (fig 2), pry in an upward motion until loose. Remove brush clip and brush assembly from motor housing (fig 3). Remove wire connector from tab on brush assembly (fig 4).

Installing new brushes: Push wire connector onto brush tab and ensure connection is secure. Insert brush into housing with the tab and wire in the down position. Slide brush assembly all the way into motor housing until it stops. Push down and inward on brush assembly, slide brush clip into top of motor housing to secure brush assembly (fig 5). When finished make sure the brush clip is flush or below motor housing (fig 6).

Note: Brush clip can only be installed one way. Do not force brush clip into motor housing or damage may occur!

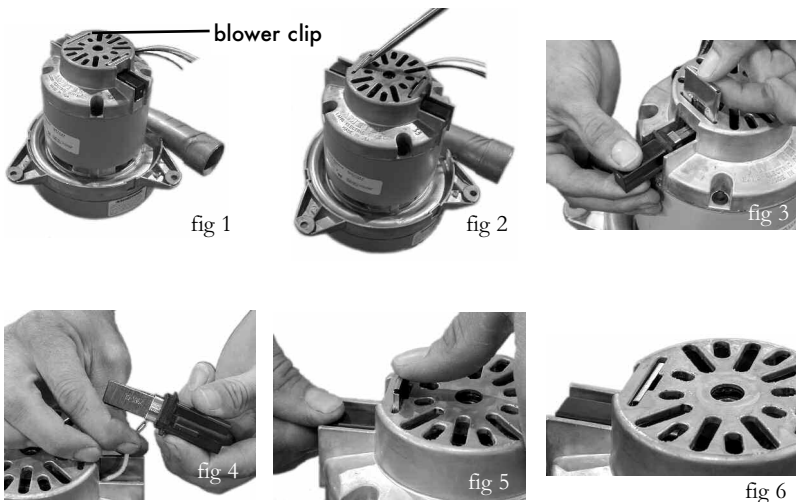

THE FORCE/2

Troubleshooting

Problem	Likely Cause	Remedy
Agitator does not operate.	Power cords not plugged in.	Check cord and plug in.
Note: Agitator can not be turned by hand.	Loose power cord/extension cord at electrical connection.	Check condition of electrical plug blades.
	Electricity not present at Blower plug. Transformer in machine not receiving electricity.	Test extension cord with known good appliance. If extension is not working check house electrical or circuit breaker at house.
	Rocker switch for agitator is not in "on" position.	Flip rocker switch "on" at main panel.
	Circuit breaker tripped on main panel.	Push to reset tripped circuit breaker.
	Jam in airlock exit tube.	Disconnect electrical power. Remove hose from the exit tube. Locate jam and remove material with pliers. See gearbox section for additional info.
	Jam between blade of agitator and airlock. Note: Jam may not be visible	Disconnect electrical power. Remove insulation material from hopper. Locate jam and remove material with pliers. See gearbox section for additional info.
	Bearing on top of gearbox worn or frozen (bearing guides the agitator shaft).	Have bearing replaced by a qualified service center.
	Start-up capacitor blown on agitator motor.	Have capacitor replaced by a qualified service center.
	Remote rocker switch for agitator motor has failed.	Replace with original factory part.
	Main panel rocker switch for agitator motor has failed.	Replace with original factory part.
Agitator turns slow.	Loose wire in electrical system.	Have the system inspected by a qualified service center.
	Run capacitor in motor worn out.	Have capacitor replaced by a qualified service center.

THE FORCE/2

Troubleshooting, Cont.

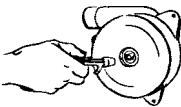
Problem	Likely Cause	Remedy
Machine makes a grinding noise when running.	Gearbox drive not engaged with airlock rotor connection out of alignment.	Loosen gearbox and gearbox stabilizers. Align gearbox and airlock shaft perpendicular to each other. Resecure bolts. Replace gearbox stabilizers if bent.
	Low oil level in gearbox.	Have the gearbox inspected and repaired by a qualified service center. See gearbox section for oil capacity.
	Agitator fan cover rubbing against rotating fan blade.	Remove black plastic cover on outside of machine. Remove agitator motor fan cover and inspect fan blade and bend cover back to normal condition.
Decreased material throw.	Worn airlock seals.	Inspect seals for tears or cuts. See maintenance section to replace or adjust as necessary.
	Kink in hose.	Run hose as straight as possible to help maintain production.
	Excess air leaking into hopper.	Inspect seals for tears or cuts. See maintenance section to replace or adjust as necessary.
	Material buildup in blower housing.	Turn machine upside down and use compressed air to blow out air intake. See diagram.
	Machine does not run	Remote cord not plugged into electrical panel
Blower power cord is not plugged in at main panel or power cord does not have electrical power at source.		Check connection on power cord at main panel or make sure electricity is present at power source.
No power.		Check source of electrical power. Possible tripped circuit breaker.

THE FORCE/2

Troubleshooting Cont.

Problem	Likely Cause	Remedy
Machine does not run Cont.	Main panel circuit breaker tripped.	Wait for a few minutes, push to reset.
Air, but no material, comes out of hose	Slide gate closed.	Open to operating position.
	Bridging (air pocket in hopper).	Turn machine "off" and disconnect from electrical power. Redistribute material in hopper. Reconnect to electrical power.
	Remote rocker switch for agitator motor has failed.	Replace with original factory part.
	Circuit breaker tripped on main panel.	Push to reset.
	Jam between blade of agitator and airlock.	Disconnect electrical power. Remove insulation material from hopper. Locate jam and remove material with pliers.
	Blower power cord is not plugged in at main panel or power cord does not have electrical power at source.	Check connection on power cord at main panel or make sure electricity is present at power source.
	Start up capacitor blown on agitator motor.	Have capacitor replaced by a qualified service center.
Blower does not operate or variable speed does operate.	Variable speed bypass switch is in the neutral position.	Position the variable speed bypass toggle switch to either the "on" or "o" position. If the switch is located in between the on/off text, it is in the neutral position and the blower will not operate.
	Blower rocker switch on main panel is "off".	Switch rocker to "on", use remote box to operate.
	Remote rocker switch for blower motor has failed.	Replace with original factory part.
	Loose power cord/extension cord at electrical system.	Check condition of electrical plug blades.

THE FORCE/2 *Troubleshooting Cont.*

Problem	Likely Cause	Remedy
Blower does not operate or variable speed does operate.	Loose wire in electrical system.	Have the system inspected and repaired by a qualified service center.
	Worn brushes in blower motor	Have the brushes inspected and replaced by a qualified service center.
	Inline fuse blown.	Turn machine upside down. Locate fuse holder on electrical box. Remove blown fuse and replace with 15 amp AG style fuse.
Agitator trips circuit breaker at main panel.	Low voltage 99-104v.	FORCE/2 requires a minimum of 20 amps @ 115V. Relocate power cord to a dedicated 20 amp circuit.
	Incorrect size extension cord.	For an additional 50' run, use 10/3 cord. For a 100' run use 8/3 cord.
	Pushing down on material in hopper.	Do not push down on insulation while filling hopper.
	Wet insulation material in hopper.	Do not use wet material. Disconnect electrical power and remove wet material.
	Worn or frozen airlock bearing.	Have bearing checked and replaced by a qualified technician.
Blower trips circuit breaker at power source.	Low voltage.	Blower requires a minimum of 20 amps @ 115V. Use a dedicated refrigerator outlet or equivalent.
	Incorrect extension cord.	For an additional 50' run, use 10/3 cord. For a 100' run use 8/3 cord.
Operator in attic keeps getting shocked.	Static electricity from insulation.	Mix half-and-half solution of water and fabric softener. Mist into insulation while loading hopper. Note: Excess moisture will cause jamming.

THE FORCE/2

Mechanical Drawings

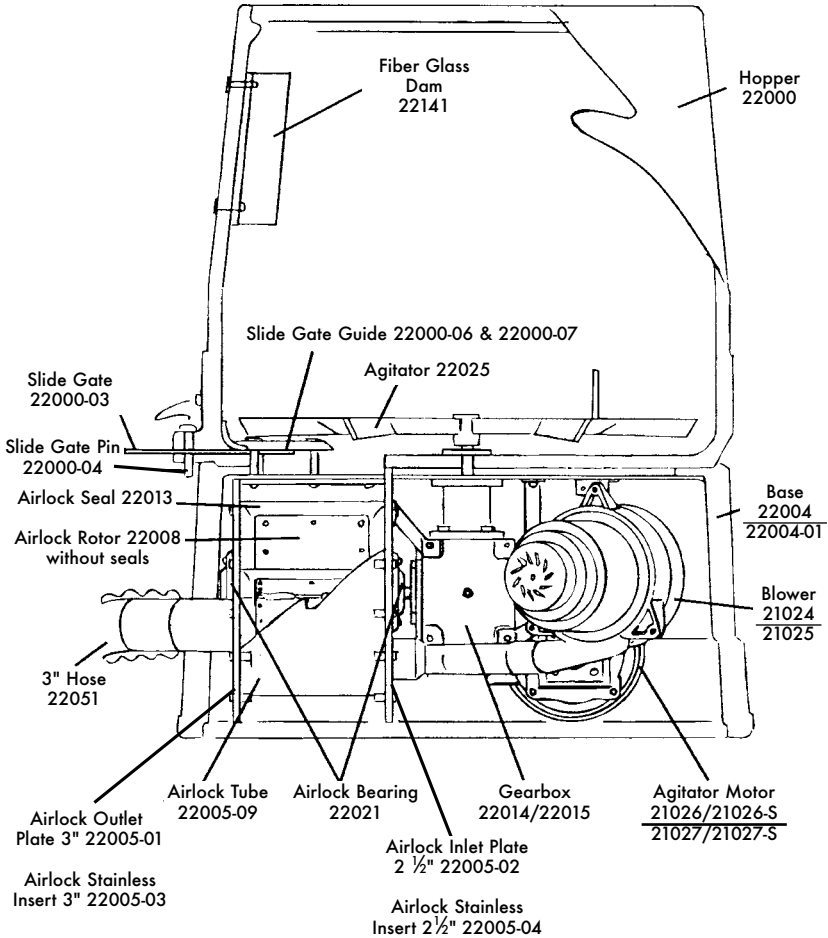

MECHANICAL DRAWINGS

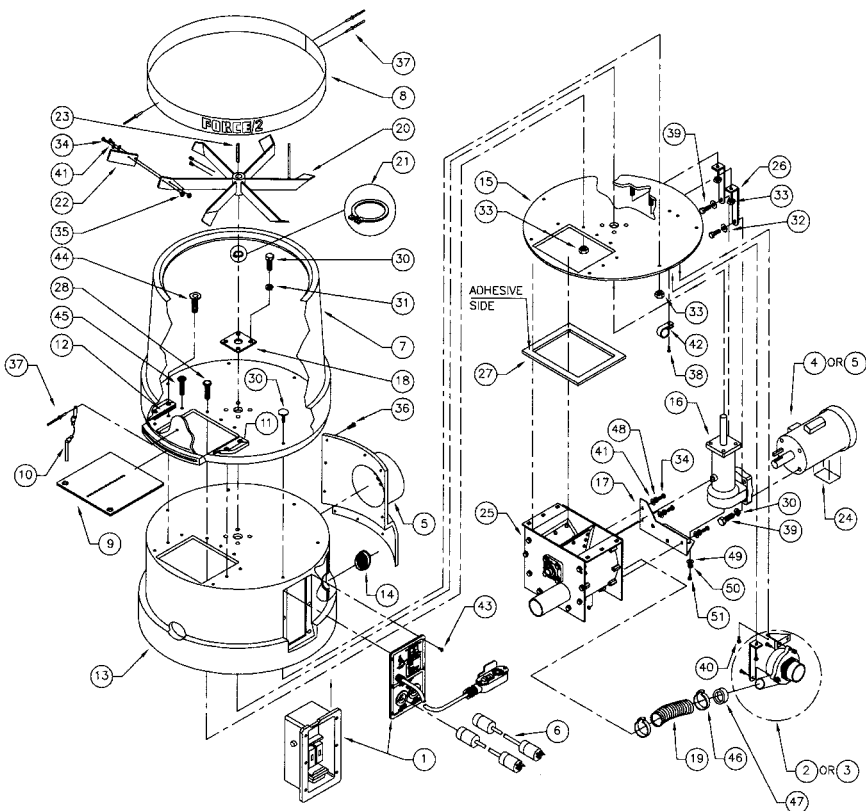

- | | | |
|--|---------------------------------------|---------------------------------------|
| 1.....21000-05-S ..ELECTRICAL SYSTEM ASSM. | 27.....22131 | AIRLOCK GASKET |
| 2.....21025-S.....BLOWER, 2 STG, 115V, 60 Hz, 105 CFM, ASSM. | 28.....F101 | 3/8 x 16 x 2-1/4" CAPR. ZN |
| 3.....21024-S.....BLOWER, 2 STG, 115V, 60 Hz, 116 CFM, ASSM. | 29.....F103 | 3/8 x 16 x 1-1/2" GIRD 2 ELEV. BOLT |
| 4.....21026-S.....AGITATOR MOTOR ASSM., 1.5 HP, 115/220V, 60Hz | 30.....F104 | 3/8 x 16 x 1-3" GIRD 5 HEX ZN |
| 4a.....21027-S.....AGITATOR MOTOR ASSM., 2 HP, 115/220V, 60 HZ | 31.....F107 | 3/8" SPLIT LOCK WASHER ZN |
| 5.....21026-16.....AGITATOR MOTOR COVER ABS 1/4" | 32.....F108 | 3/8" FLAT WASHER SAE |
| 6.....21060-01 | 33.....F109 | 3/8 x 16 NYLON LOCK NUT ZN |
| POWER CORD 100' 12/3 COMP, TWIST LOCK | 34.....F112 | 1/4 x 20 x 7/8" GIRD 5 HEX ZN |
| 7.....22000 | 35.....F114 | 1/4 x 20 NYLON LOCK NUT ZN |
| HOPPER, STD, BLUE | 36.....F123 | #6 x 3/4" SMS PP BLACK |
| 8.....22000-02 | 37.....F130 | 3/16 x 11/16" ALUM. RIVET |
| HOPPER BELLY BAND, STD | 38.....F142 | # 8 x 32 x 1/2" PP, TYPE B, SELF TAP. |
| 9.....22000-03.....SLIDE GATE, F/2, STD | 39.....F143 | 3/8 x 16 x 1" GIRD 5 HEX ZN |
| 10.....22000-04.....SLIDE GATE CABLE & PIN | 40.....F152 | 1/4 x 20 x 1/2" GIRD 2 ROLOCK |
| 11.....22000-06.....SLIDE GATE GUIDE, RIGHT | 41.....F159 | 1/4" FLAT WASHER SAE |
| 12.....22000-07.....SLIDE GATE GUIDE, LEFT | 42.....F162 | CABLE CLAMP NYLON |
| 13.....22004 | 43.....F223 | # 10 x 32 x 5/8" PHILL TRUSS ZN |
| BASE, STD, BLACK | 44.....F332 | 3/8 x 16 x 2" SOCKET FLAT CAP SCREW |
| 14.....22001-01.....BASE HOUSING LOUVER 3" | 45.....F333 | 3/8 x 16 x 1-1/2" SOCKET BUTTON SCREW |
| 15.....22003-01.....BASE PLATE, 1/4" x 28" | 46.....22050-04.....BLOWER CLAMP | |
| 16.....22014 | 47.....22026.....BLOWER REDUCING RING | |
| GEARBOX, F/2 | 48.....F115 | 1/4" SPLIT LOCK WASHER, ZN |
| 17.....22015-34.....GEARBOX Stabilizer | 49.....F363 | # 14 FLAT WASHER, ZN |
| 18.....22015-22.....GEARBOX SUPPORT PLATE 4" x 4" | 50.....F199 | M8 SPLIT LOCK WASHER, ZN |
| 19.....22023-01.....BLOWER COUPLING 8" LONG | 51.....F198 | M8-1.25 x 25 HEX C/S METR. ZN |
| 20.....22025.....AGITATOR, STD W/SET SCREWS | | |
| 21.....22025-01.....AGITATOR SNAP RING 1" | | |
| 22.....22025-02.....AGITATOR NEOPRENE PAD 1/4" | | |
| 23.....22025-03.....KEY 1/4" x 2-1/2" | | |
| 24.....22025-05.....AGITATOR MOTOR ROTATION LABEL | | |
| 25.....22042-01-S ..AIRLOCK ASSM. W/BEARINGS & SS INSERTS | | |
| 26.....22053-02.....AGITATOR MOTOR SUPPORT BRACE | | |

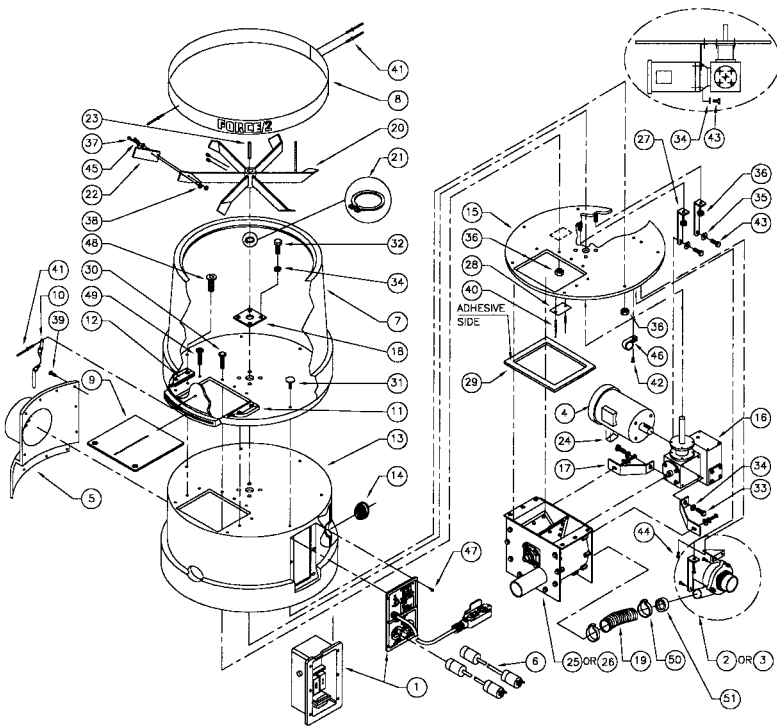

- | | |
|--|--|
| 1.....21000-S.....ELECTRICAL SYSTEM ASSM.
W/RS&VSC | 25.....22042-S.....AIRLOCK ASSM. W/BEARINGS. STD |
| 2.....21025-S.....BLOWER, 2 STG 115 V, 60HZ,
105 CFM, ASSM. | 26.....22042-01-S ..AIRLOCK ASSM. W/BEARINGS
& SS INSERTS |
| 3.....21024-S.....BLOWER, 2 STG 115 V, 60HZ,
116 CFM, ASSM. | 27.....22053-01.....AGITATOR MOTOR
SUPPORT BRACE |
| 4.....21026-S.....AGITATOR MOTOR ASSM., 1.5 HP,
115/220V, 60 HZ | 28.....22106SERIAL TAG FORCE/2 |
| 5.....21026-07.....AGITATOR MOTOR COVER ABS 1/4" | 29.....22131AIRLOCK GASKET |
| 5a.....21026-17.....AGITATOR MOTOR COVER 1/4" HC | 30.....F1013/8"16 X 2-1/4" CARRIAGE ZN |
| 6.....21060-01.....POWER CORD 100' 12/3 COMP,
TWIST LOCK | 31....F1033/8"16 X 1-1/2" GRD 2 ELEV. BOLT |
| 7.....22000HOPPER, STD, BLUE | 32....F1043/8"16 X 1-3/4" GRD 5 HEX ZN |
| 8.....22000-02HOPPER BELLY BAND, STD | 33....F1063/8"16 X 3/4" GRD 5 HEX ZN |
| 9.....22000-03SLIDE GATE, F/2, STD | 34....F1073/8" SPLIT LOCK WASHER ZN |
| 10....22000-04.....SLIDE GATE CABLE & PIN | 35....F1083/8" FLAT WASHER SAE |
| 11....22000-06SLIDE GATE GUIDE, RIGHT | 36....F1093/8"16 NYLON LOCK NUT ZN |
| 12....22000-07.....SLIDE GATE GUIDE, LEFT | 37....F1121/4"20 X 7/8" GRD 5 HEX ZN |
| 13....22004-01BASE, STD, BLACK HC | 38....F1141/4"20" NYLON LOCK NUT ZN |
| 14....22001-01BASE HOUSING LOUVER 3" | 39....F123#6 X 3/4" SMS PP BLACK |
| 15....22003-01.....BASE PLATE, 1/4" X 28" | 40....F1293/32" X 11/32" ALUM. RIVET |
| 16....22015GEARBOX, F/2 | 41....F1303/16" X 11/16" ALUM. RIVET |
| 17....22015-21.....GEARBOX STABILIZER | 42....F142#8*32 X 1/2" PP, TYPE B, SELF TAP. |
| 18....22015-22.....GEARBOX SUPPORT PLATE 4" X 4" | 43....F1433/8"16 X 1" GRD 5 HEX ZN |
| 19....22023-01.....BLOWER COUPLING 8" LONG | 44....F1521/4"20 X 1/2" GRD 2 ROLOCK |
| 20....22025AGITATOR, STD W/SET SCREWS | 45....F1591/4" FLAT WASHER NYLON |
| 21....22025-01.....AGITATOR SNAP RING 1" | 46....F162CABLE CLAMP NYLON |
| 22....22025-02AGITATOR NEOPRENE PAD 1/4" | 47....F223#10*32 X 5/8" PHILL TRUSS ZN
FLAT CAP SCREW |
| 23....22025-03KEY 1/4" X 2-1/2" | 48....F3323/8"16 X 2" SOCKET |
| 24....22025-05AGITATOR MOTOR ROTATION LABEL | 49....F3333/8"16 X 1-1/2"
SOCKET BUTTON SCREW |
| | 50....22050-04.....BLOWER CLAMP |
| | 51....22026BLOWER REDUCING RING |

Airlock Assembly

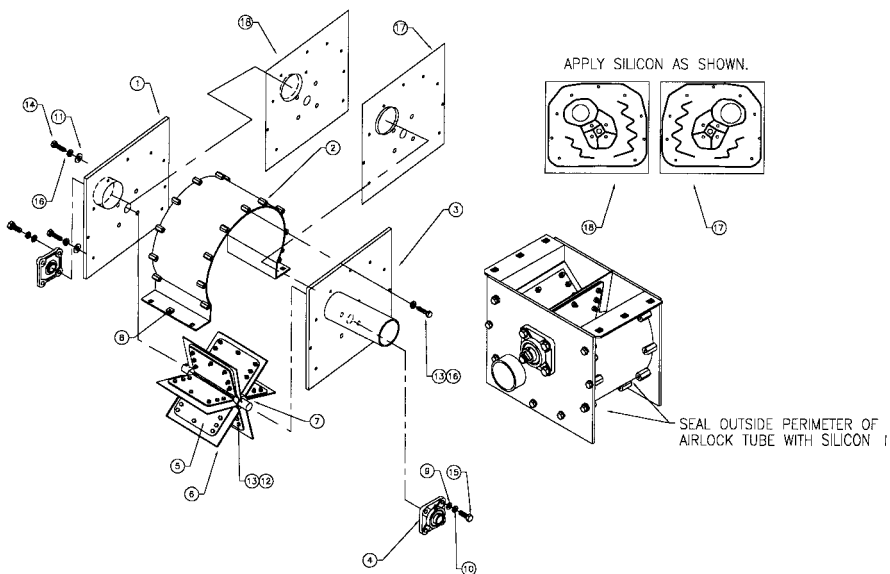

Item #	PART NUMBER	DESCRIPTION
1	22005-02	AIRLOCK INLET PLATE ASSM. 2 1/2"
2	22005-09	AIRLOCK TUBE 12" (CRS)
3	22005-01	AIRLOCK OUTLET PLATE ASSM. 3"
4	22021	AIRLOCK BEARING FLANGE 4 HOLE
5	22008	AIRLOCK ROTOR ASSEMBLY W/O SEAL
6	22013	AIRLOCK SEAL
7	22116	AIRLOCK WEAR WASHER
8	F221	CAGE NUT ZN
9	F353	3/8" INTERNAL LOCK WASHER ZN
10	F108	3/8" FLAT WASHER SAE
11	F159	1/4" SAE FLAT WASHER
12	F114	1/4*20 NYLON LOCKNUT ZN
13	F112	1/4*20 x 7/8" GRADE 5 HEX HEAD ZN
14	F110	1/4*20 x 1 #9 HEX YELL. ZN
15	F105	3/8-24 x 7/8" GRADE 5 HEX HEAD ZN
16	F115	1/4" SPLIT LOCK WASHER ZN
17	22005-03	OUTLET SS INSERT 3"
18	22005-04	INLET SS INSERT 2-1/2"

Airlock Rotor

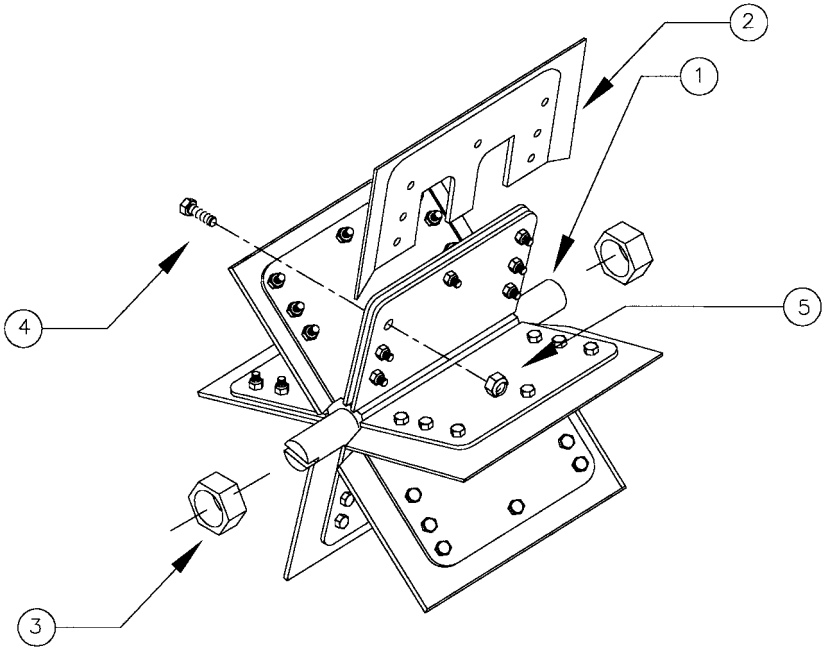

Item #	PART NUMBER	DESCRIPTION
122008AIRLOCK ROTOR ASSM. W/O SEALS
222013AIRLOCK SEAL
322116WEAR WASHER NYLON 5/8"
4F1121/4*20x7/8 GRADE 5 HEX HEAD ZN
5F1141/4*20 NYLON LOCKNUT ZN

Model 21024
116 CFM Blower

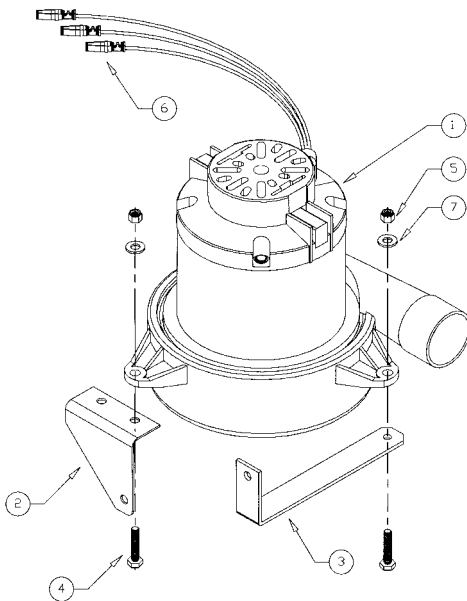

Item # PART NUMBER DESCRIPTION

121025BLOWER 2 STG., 115V, 60 Hz, 105 CFM
121024BLOWER 2 STG., 115V, 60 Hz, 116 CFM
n/a21025-05Blower Brush (set of two)
222022-BLOWER MOUNTING BRACKET
322022-01BLOWER MOUNTING BRACKET 6-3/4"
4F1121/4*20 X 7/8" GRADE 5 HEX, ZN
5F1141/4" NYLON INSERT LOCKNUT, ZN
6F146ELECTRICAL BOX FEMALE CONTACT
7F1591/4" SAE FLAT WASHER

Model 21025
105 CFM Blower

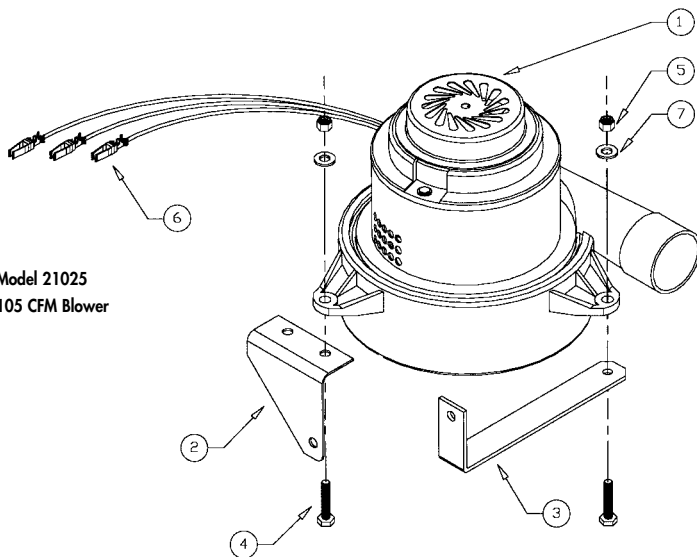

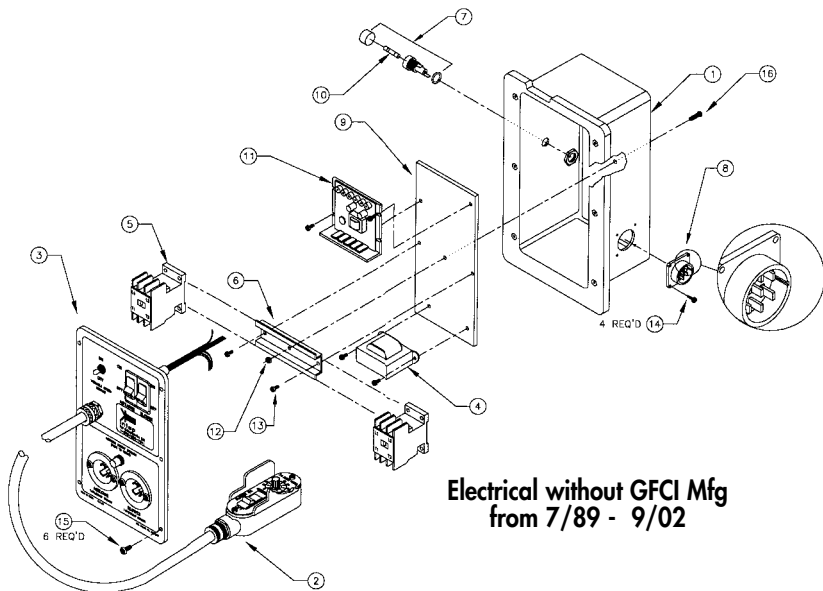

Electrical without GFCI Mfg
from 7/89 - 9/02

Item # PART NUMBER DESCRIPTION

1R22001-02.....	ELECTRICAL BOX W/HOLES
221012-00-S.....	REMOTE CORD 18/7 x 100' COMP. W/RS & VSC
321016-S.....	ELECTRICAL PANEL ASSM.
421002.....	TRANSFORMER 110 VOLT
521003-02.....	ELECTRICAL CONTACTOR (2 HP)
621003-03.....	ELECTRICAL CONTACTOR MOUNT RAIL
721017-02.....	FUSE HOLDER, BLOWER
821019.....	ELECTRICAL BOX FLANGE CONNECTOR
921020.....	ELECTRICAL BOX MOUNTING PLATE
1021025-07.....	FUSE, 15 AMPS
1121143-06.....	VARIABLE SPEED CONTROL
12F120.....	.8*32 NYLON INSERT LOCK NUT
13F126.....	.8*32 X 1 4 PP ZN
14F158.....	.#6 X 1/2" SMS PP ZN
15F223.....	.10*32 X 5/8" PT ZN
16F141.....	.8*32 X 1/2" PP ZN

Electrical without GFCI Mfg from 7/89 - 9/02

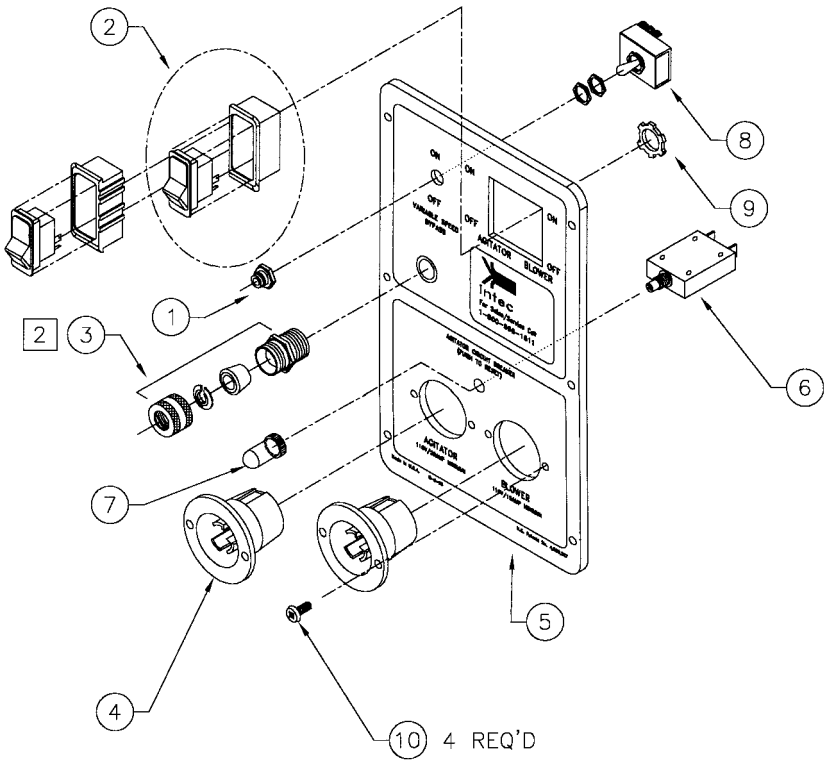

Item # PART NUMBER DESCRIPTION

111072REMOTE BOX TOGGLE SWITCH SEAL
221000-02-SROCKER SWITCH, PANEL
321008-02STRAIN RELIEF, ALUM. 1/2"
421010ELECTRICAL FLANGE RECEPTACLE TWIST 15 AMP
521016-0ELECTRICAL FACE PLATE "STD" 1996 W/SILK SCREEN
621045-01CIRCUIT BREAKER 20 AMP
721045-02CIRCUIT BREAKER BUTTON SEAL
821143-07VARIABLE SPEED BYPASS SWITCH
9F132STRAIN RELIEF LOCK NUT 1/2"
10F1198*32 x 3/8" PP ZN

Electrical without GFCI Mfg
from 7/89 - 9/02

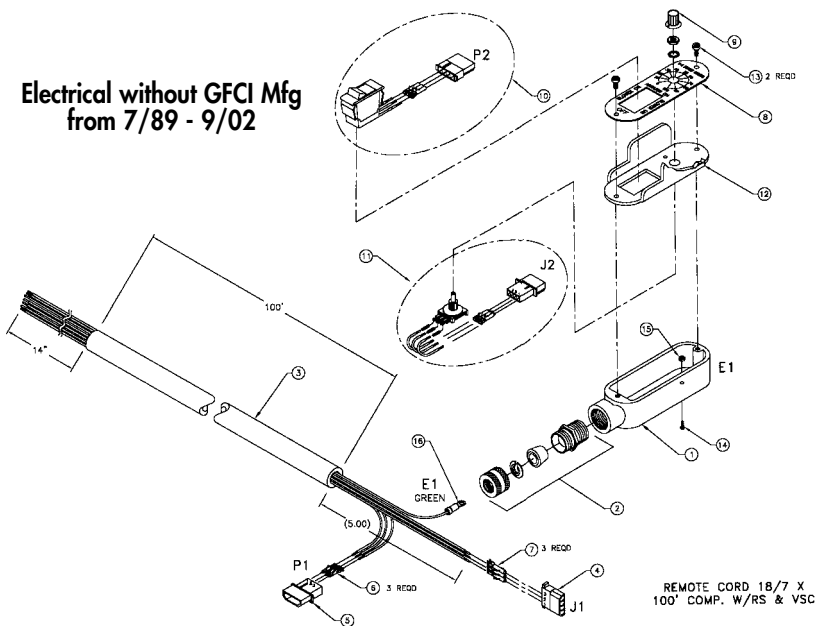

REMOTE CORD 18/7 X
100' COMP. W/RS & VSC

Item # PART NUMBER DESCRIPTION

121008-0REMOTE BOX 3/4 W/HOLE
221008-09STRAIN RELIEF, ALUMINUM, 3/4"
321008-10REMOTE CORD 18/7 X 100' (ONLY)
421008-12REMOTE BOX CONNECTOR SOCKET MALE
521008-13REMOTE BOX CONNECTOR SOCKET FEMALE
621008-14REMOTE BOX CONTACT PIN MALE
721008-15REMOTE BOX CONTACT PIN FEMALE
821008-17REMOTE BOX 3/4" SHIELD STICKER
921143-01VARIABLE SPEED KNOB
1021021-SREMOTE BOX ROCKER SWITCH ASSM.
1121143-03-SVSC POT. ASSM.
12RR21008-08REMOTE BOX 3/4" SHIELD W/O STICKER
13F1198*32 X 3/8 PP ZN
14F1226*32 X 3/8 PP BLACK
15F1246*32 NYLON INSERT LOCK NUT
16F153#6 RING TERMINAL BLUE

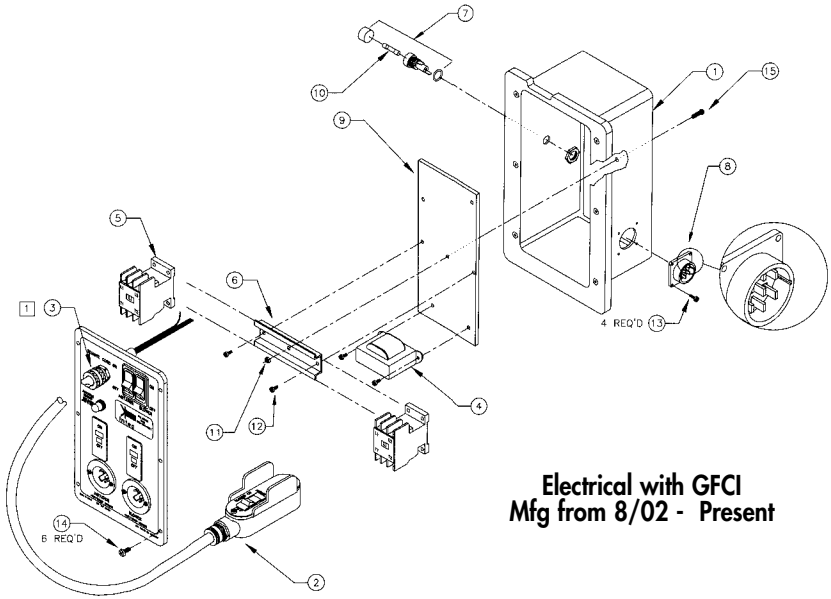

Electrical with GFCI
Mfg from 8/02 - Present

Item # PART NUMBER DESCRIPTION

1R22001-02ELECTRICAL BOX W/HOLES
221006-SREMOTE CORD 18/4 x 100' ASSM.
321016-02-SELECTRICAL PANEL ASSM.
421002TRANSFORMER 110 VOLT
521003-02ELECTRICAL CONTACTOR (2 HP)
621003-03ELECTRICAL CONTACTOR MOUNT RAIL
721017-02FUSE HOLDER, BLOWER
821019ELECTRICAL BOX FLANGE CONNECTOR
921020ELECTRICAL BOX MOUNTING PLATE
1021025-07FUSE, 15 AMPS
11F1208-32 NYLON INSERT LOCK NUT
12F1268-32 X 1/4 PP ZN
13F1586 X 1/2 SMS PP ZN
14F22310-32 X 5/8" PP ZN
15F1 418-32 X 1/2" PP ZN

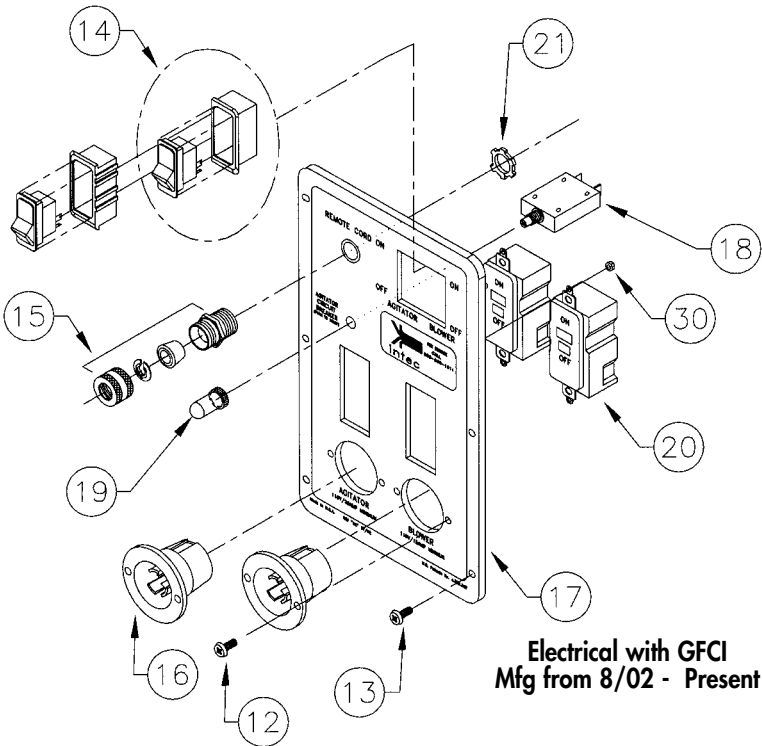

**Electrical with GFCI
Mfg from 8/02 - Present**

Item # PART NUMBER DESCRIPTION

12F1198-32X3/8 PP ZN
13F22310-32X5/8 FIL TRUSS ZN
1421000-02ROCKER SWITCH, PANEL
1521008-02STRAIN RELIEF, ALUM. 1/2"
1621010ELECTRICAL FLANGE RECEPTACLE, TWIST 15 AMP.34
1721016-03ELECTRICAL FACE PLATE "OC" W/SILK SCREEN
1821045-01CIRCUIT BREAKER 20 AMP.
1921045-02CIRCUIT BREAKER BUTTON SEAL
2001002GROUND FAULT CIRCUIT, 20 AMP.
21F132STRAIN RELIEF LOCK NUT 1/2"
30F1246-32 NYLON INSERT LOCK NUT

Remote Box Assembly

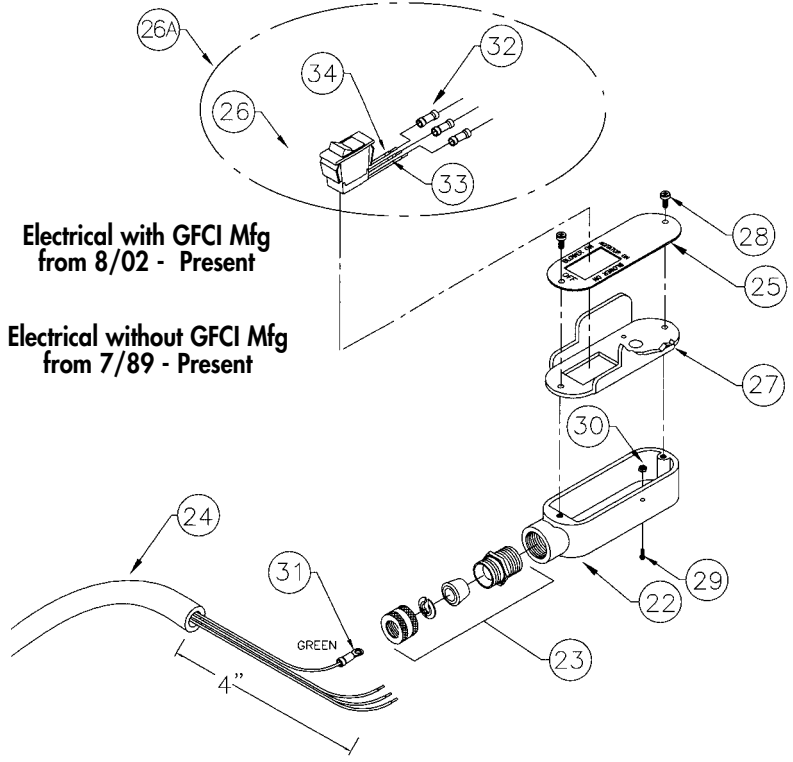

Item #	PART NUMBER	DESCRIPTION
22	21008-0	REMOTE BOX 3/4" W/HOLE
23	21008-09	STRAIN RELIEF, ALUM. 3/4"
24	21008-03	REMOTE CORD 18/4X100' (ONLY)
25	01009	REMOTE BOX 31" SHIELD STICKER
26	RR21021-01	REMOTE BOX ROCKER SWITCH
26A	11008-06-01-S	REMOTE BOX ROCKER SWITCH ASSM.
27	RR21004	REMOTE BOX 3/4" SHIELD W/O STICKER
28	F119	8-32X3/8 PP ZN
29	F122	6-32X3/8 PP ZN
30	F124	6-32 NYLON INSERT LOCK NUT
31	F153	#6 RING TERMINAL, BLUE
32	F136	BUTT SPLICE, BLUE
33	F230	SHRINK TUBE 3/16X1/4", WHITE
34	F231	SHRINK TUBE 3/16X1/4", RED

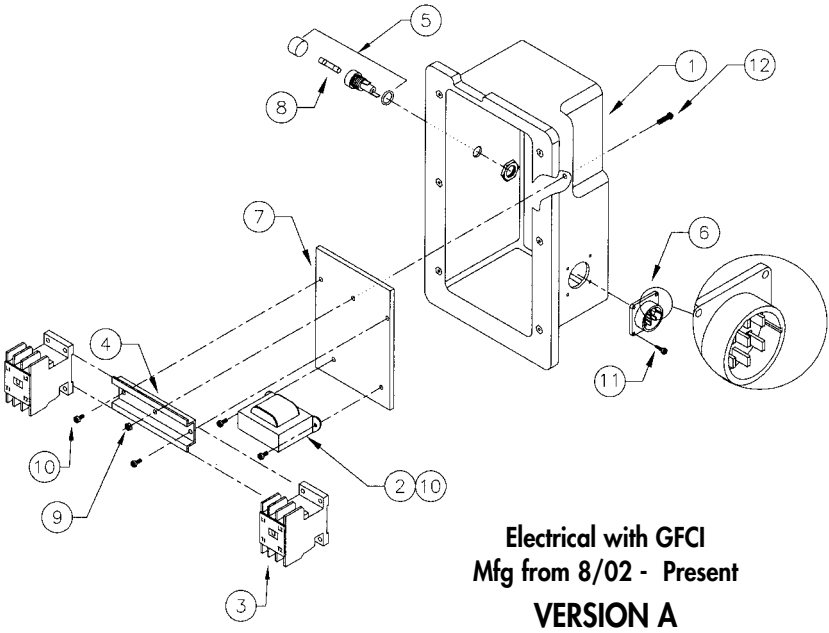

**Electrical with GFCI
Mfg from 8/02 - Present
VERSION A**

Item #	PART NUMBER	DESCRIPTION
1	22001-03	ELECTRICAL BOX W/CURVE, WHOLES
2	21002	TRANSFORMER 110 VOLT
3	21003-02	ELECTRICAL CONTACTOR (2 HP)
4	21003-03	ELECTRICAL CONTACTOR MOUNT RAIL
5	21017-02	FUSE HOLDER, BLOWER
6	21019	ELECTRICAL BOX FLANGE CONNECTOR
7	21020-01	ELECTRICAL BOX MOUNTING PLATE 1/8 X 5 X 6-3/8
8	21025-07	FUSE, 15 AMPS
9	F120	8-32 NYLON INSERT LOCK NUT
10	F126	8-32 X 1/4 PP ZN
11	F158	6 X 1/2 SMS PP ZN
12	F141	B-32 X 1/2" PP ZN

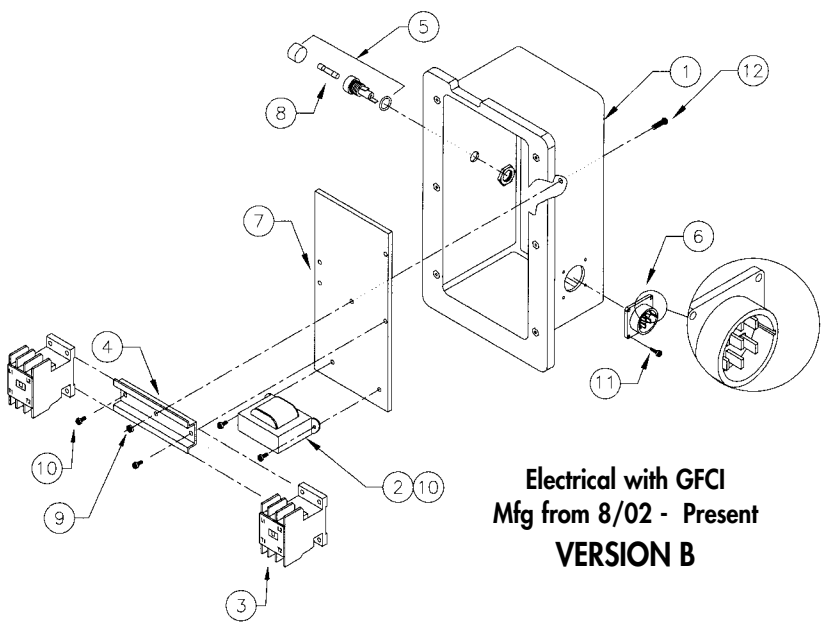

Electrical with GFCI
Mfg from 8/02 - Present
VERSION B

Item #	PART NUMBER	DESCRIPTION
1	R22001-02	ELECTRICAL BOX W/ HOLES
2	21002	TRANSFORMER 110 VOLT
3	21003-02	ELECTRICAL CONTACTOR (2 HP)
4	21003-03	ELECTRICAL CONTACTOR MOUNT RAIL
5	21017-02	FUSE HOLDER, BLOWER
6	21019	ELECTRICAL BOX FLANGE CONNECTOR
7	21020	ELECTRICAL BOX MOUNTING PLATE
8	21025-07	FUSE, 15 AMPS
9	F120	8-32 NYLON INSERT LOCK NUT
10	F126	8-32 X 1 4 PP ZN
11	F158	6 X 1/2 SMS PP ZN
12	F141	B-32 X 1/2" PP ZN

Wiring Diagram Manufactured from 8/02 - Present Electrical with GFCI

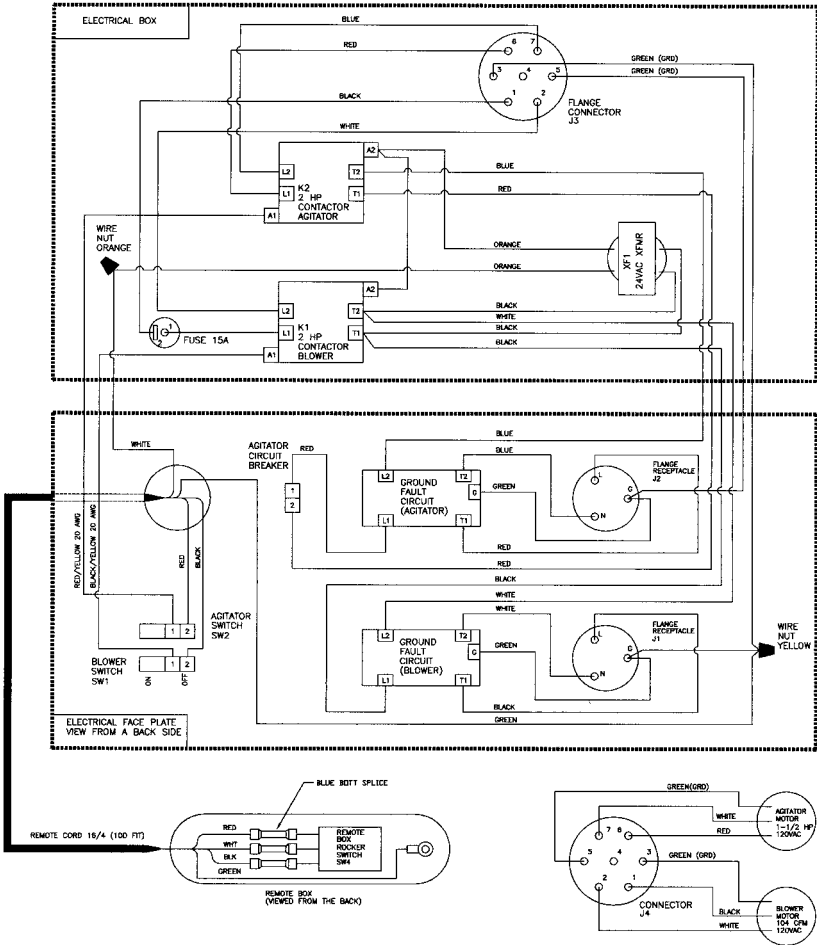

Electrical with Remote
Disconnect
Mfg from 9/02 - Present

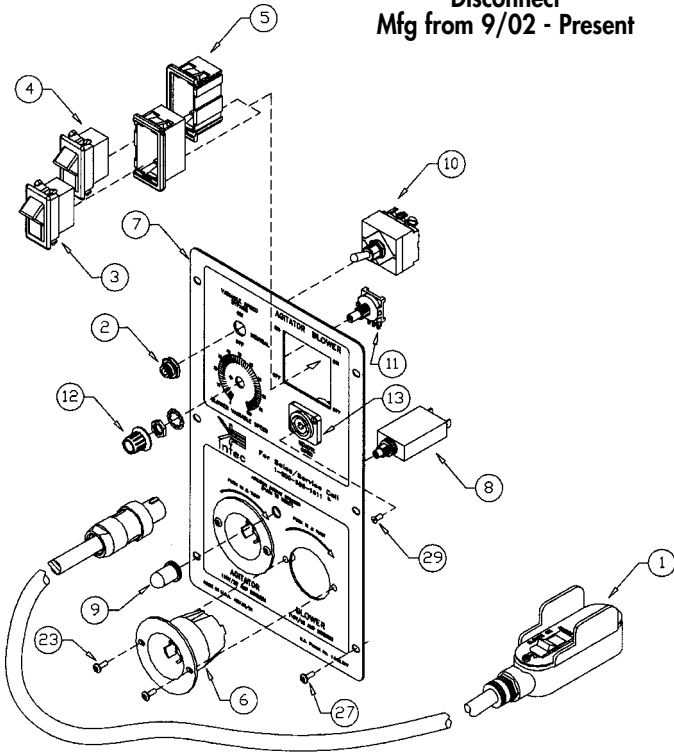

Item # PART NUMBER DESCRIPTION

121006-SREMOTE CORD/BOX 18/4X100' ASSM. (see page 41 for more detailed remote cord drawings)
211072REMOTE BOX TOGGLE SWITCH SEAL
321000-03ROCKER SWITCH, BLACK
421000-04ROCKER SWITCH, RED
521000-02ROCKER SWITCH PANEL
621010ELEC. FLANGE RECEPT. TWIST 15AMP
721016-02ELECTRICAL FACE PLATE 2002
821045-01CIRCUIT BREAKER 20 AMP
921045-02CIRCUIT BREAKER BUTTON SEAL
1021143-07VARIABLE SPEED BYPASS SWITCH
1121143-05-SVS POTENTIOMETER 1K, ASSM.
1221143-01VARIABLE SPEED KNOB
1321021REMOTE QUICK DISCONNECT FEMALE RECEPTACLE
23F119#32X3/8" PP ZN
27F223#10-32X5/8" PT ZN
29F190#4-40X1/4" PP ZN

Electrical with Remote Disconnect Mfg from 9/02 - Present

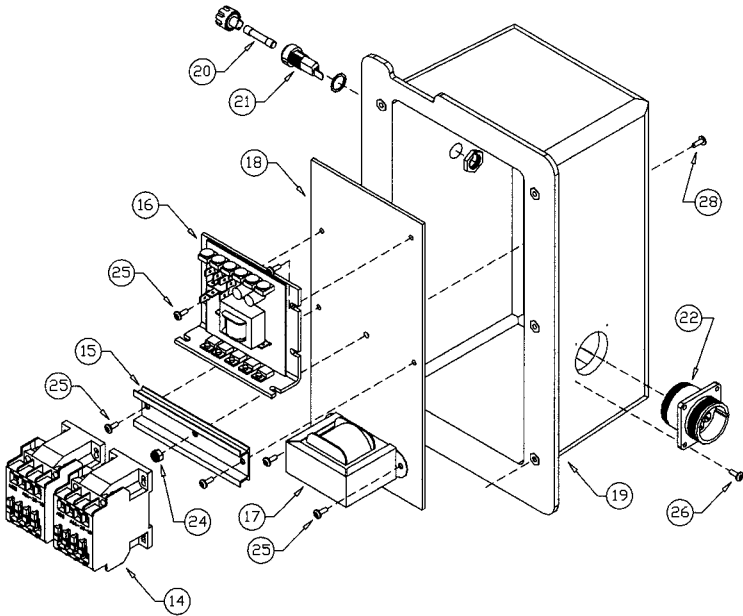

Item # PART NUMBER DESCRIPTION

1421003-02ELECTRICAL CONTACTOR 2 HP
1521003-03ELECTRICAL CONTACTOR MOUNT RAIL
1621143-06VARIABLE SPEED CONTROL
1721002TRANSFORMER 110/24 VAC
1821020ELECTRICAL BOX MOUNTING PLATE
19R22001-02ELECTRICAL BOX W/HOLES
2021025-07FUSE, 15 AMP
2121017-02FUSE HOLDER
2221019ELECTRICAL BOX FLANGE CONNECTOR
23F119#-32x3/8" PP ZN
24F120#8-32 NYLON INSERT LOCK NUT
25F126#8-32x1/4" PP ZN
26F158#6x1/2 SMS PP ZN
27F223#10-32x5/8" PT ZN
28F141#8-32x1/2" PP ZN
29F190#4-40x1/4" PP MC

THE FORCE/2 *Claims, Damage or Loss*

These goods were carefully packed and thoroughly inspected before leaving our factory. Responsibility for its safe delivery was assumed by the carrier upon acceptance of the shipment. Inspect shipment carefully on the arrival for damage to contents, shortages or equipment. In case of damage, save container and packing material for inspection. Claims for loss or damage sustained in transit must, therefore, be made upon the carrier, as follows:

1. CONCEALED LOSS OR DAMAGE. Concealed loss or damage means loss or damage which does not become apparent until the merchandise has been unpacked. The contents may be damaged in transit due to rough handling even though the carton may not show external damage. When the damage is discovered upon unpacking, make a written request for inspection by the carrier's agent within ten days of the delivery date. Then file a claim with the carrier since such a claim is the carrier's responsibility.

2. VISIBLE LOSS OR DAMAGE. Any external evidence of loss or damage must be noted on the freight bill or the express receipt, and signed by the carrier's agent. Failure to adequately describe such external evidence of loss or damage may result in the carrier refusing to honor a damage claim. The form required to file such a claim will be supplied by the carrier.

3. SHORTAGE. If the number of containers in the shipment does not correspond with the transportation bill, obtain carrier's notation of shortage and signature on transportation bill. When the number of containers is correct, but there is indication of pilferage, notify carrier in writing with a complete list of missing merchandise.

THE FORCE/2 *Claims, Damage or Loss*

Claims for loss or damage must be filed with the carrier by the consignee **within 24 hours after receipt of goods.** We will assist you in every possible manner but cannot be responsible for the collection of a claim or the cost of replacement of the damaged goods.

If you have any questions regarding the above information please feel free to contact an INTEC representative.

RETURNS

We at INTEC sincerely hope the merchandise you have just received is in excellent condition and satisfies your expectations. If not, please look below and follow the instructions which apply to your particular situation.

MERCHANDISE IS DAMAGED.

If the carrier is UPS:

Keep the merchandise in the original packing materials and carton.

Call UPS at (800) 742-5877 or contact them using their web address: www.ups.com/using/custserv/ to notify them of the damaged package.

Fill out the information sheet on the following page and mail or fax it to the attention of the Shipping Department.

Upon return of this form and/or the damaged merchandise, we will send a replacement or credit your account.

Other than UPS:

Keep the merchandise in the original packing materials and carton.

Call the Shipping Department at the number on the following page for further instructions.

Upon return of this form and/or the damaged merchandise by the carrier, we will send you a replacement or credit your account. Do not return any merchandise through the U.S. Post Office.

MERCHANDISE IS PERSONALLY UNSATISFACTORY TO YOU.

You may return the merchandise, along with a RMA number on outside of carton and a copy of your invoice to the Shipping Department at the address provided on the next page. Upon its return intact, we will send a refund or credit your account. A restocking fee may be charged.

THE FORCE/2

Returns

SHIPMENTS TO FACTORY

All shipments to the factory must have a RMA number on the outside of the carton. You will be given a RMA number when you contact the Sales Department. The RMA is the only way to track and assure that your request is handled properly. If you received an invoice with your merchandise, please include a copy of the invoice with all returned materials.

Company Name _____

Contact Name _____

Phone _____ Fax _____

Address _____

City _____ State _____ Zip _____

Comments _____

Invoice Number _____ RMA Number _____

Shipping Department Ph: 1-303-833-6644
INTEC 1-800-666-1611
3771 Monarch Street Fax: 1-303-833-6650
Frederick, CO 80530 E-mail: info@inteccorp.com

THE FORCE/2

Receiving Replacement Parts

When you call INTEC, please have available the model number and serial number of your machine, as well as description of the defective part or an explanation of the defect.

We will issue a **Return Merchandise Authorization (RMA)** number and instructions to return the defective part. All shipments to INTEC must be sent via UPS, except in the case of complete machines, when a common carrier should be used. The warranty on your machine does not cover **freight or labor charges**. All shipments to the factory or service center must be freight prepaid. No freight collect shipments will be accepted without prior approval.

Your RMA number must appear on the outside of any returned cartons. We assume no responsibility for incoming lost or untraceable shipments. RMA numbers expire 30 days after issue date. Shipments beyond the 30-day expiration may not be credited.

We will repair or replace, at our option, any returned part found to be defective in materials or workmanship under the terms of our limited warranty. Repaired or replaced parts will be returned to you freight collect.

If we determine the part failure was due to misuse, alteration, negligence, accident or operating beyond rated capacity, we will contact you. At your option, we will send you a new part at the prevailing price or return the failed part to you. All shipments from the factory are sent freight collect.

If you require a replacement part prior to a warranty decision, we will send the part to you at the prevailing price, under your current terms. When we receive the defective part and a warranty decision has been made, INTEC will either issue a credit to your account or return the failed part to you.

Shipping Department Ph: 1-303-833-6644
INTEC 1-800-666-1611
3771 Monarch Street Fax: 1-303-833-6650
Frederick, CO 80530 E-mail: info@inteccorp.com

THE FORCE/2 *Warranty*

It is expressly understood and agreed that no officer, agent, salesman or employee of the Manufacturer INTEC has the authority to obligate the Manufacturer by any terms, stipulations, or conditions not herein expressed; that all previous representations and agreements, either verbal or written, referring to the machinery and equipment, which is the subject of this Warranty, are hereby superseded and canceled, and that there are no promises or agreements outside of this Warranty agreement. Furthermore, the manufacturer hereby disclaims any implied warranties of merchantability, or implied warranties of fitness for a particular purpose.

With the above understanding, the Manufacturer's FORCE/2 insulation blowing machine is sold with the following one (1) year Limited Warranty, and no other:

- a) Manufacturer warrants to the original purchaser that the machine is well made, of good material and durable; but only if the machine is operated and maintained in accordance with this Operator's Manual and the Maintenance Manual. This Warranty is void if the machine is not so operated and maintained, or if the machine is used for blowing materials other than those which are intended to be used with the machine.

- b) Manufacturer guarantees the machine to be free from manufacturing defects at the time of shipment, and to remain free from defects when operated under normal use, for a period of one (1) year from the date of factory shipment, with the exception of the blower, electrical and airlock components, which are guaranteed for a period of ninety (90) days from date of factory shipment.

- c) This Warranty shall not apply to any machine or component part which, in the opinion of the Manufacturer, has been altered, subject to misuse, negligence, accident or operated beyond factory rated capacity. All requested Warranty work shall be performed at Manufacturer's factory or by an Authorized Factory Service Facility. Failure to have the Warranty work done at Manufacturer's factory or by an Authorized Factory Service Facility will void this Warranty. Manufacturer will bear full responsibility to repair or replace, at its option, without charge to the original purchaser, any part which, in the Manufacturer's opinion, is found to be defective.

- d) All parts claimed defective by original purchaser shall be returned, properly identified, to Manufacturer's factory or Authorized Factory Service facility, freight prepaid. All replacement, repaired or non-defective parts will be returned to purchaser, freight collect. Manufacturer will supply replacement parts prior to receipt of any parts claimed defective, only with the understanding that such replacement parts will be shipped to purchaser at the then prevailing price of said part, C.O.D, freight collect. Manufacturer will reimburse cost of any such part only after receipt and inspection, and finding said part defective.

- e) Manufacturer's liability is expressly limited to the repair or replacement of defective parts set forth in this Warranty. All other damages and warranties, statutory or otherwise, being waived by original purchaser as a condition of sale and purchase of said machines. Furthermore, the Manufacturer shall not be liable for damages or delays caused by defective material or workmanship.

This Warranty applies only to the original purchaser and is not transferable.

THE FORCE/2

Insulation Terms and Values

R-VALUE: The resistance (R) to heat or cold. The higher the R Value, the greater the resistance and the better the insulation factor.

SETTLEMENT: All blown insulation will settle after installation. Your FORCE/2 installs near settled density. Consult the chart on the material bag for coverage and install accordingly.

COVERAGE: Every bag of material comes with a coverage chart detailing R-Value ratings. Average ratings for various materials are:

Cellulose:	R = 3.7 per inch
Rockwool:	R = 2.6 per inch
Fiberglass:	R = 2.2 per inch

CFM: Blowers are measured by **C**ubic **F**oot per **M**inute. A low CFM blower reduces “dust” when blowing insulation into an attic. The FORCE/2 features the lowest CFM of all insulation blowing machines, minimizing the “dust” problem. You’ll be able to see what you are doing.

PSI: Blowers are also rated by **P**ounds of pressure per **S**quare **I**nch. A high PSI does a better job of blowing insulation. Your FORCE/2 produces 3.2-4.0 PSI which is the best for blowing insulation.

BRIDGING: A pocket of air, or void, created by improper agitation in the hopper. A “bridge” can stop production until cleared. Your FORCE/2 is designed with a non-bridging hopper. However, you may experience a temporary bridge while using your machine. Waiting a few seconds will most likely clear a temporary bridge. If not, unplug your machine and redistribute the material in the hopper.

VENTILATION: Proper air flow requires one square foot of air movement for every 150 square feet of attic area.

AIRLOCK SEAL: Also known as flapper, rubbers, paddles.

THE FORCE/2*Insulation Terms and Values, Cont.*

COMMON INSULATION VALUES

Material	Thickness	R-Value
Air Space	1"	1.01
Cellulose loose fill	1"	3.70
Celotex	1"	3.03
Concrete block	8", hollow	1.11
Fiberglass batt	3½"	11.0
Fiberglass batt	8"	19.0
Fiberglass loose fill	1"	2.2
Rockwool batt	¾"	11.0
Rockwool batt	6 - 7½"	22.0
Rockwool loose fill	1"	2.60
Plywood	½"	.62
Polyurethane board	1"	6.25
Vermiculite	1"	2.13