

WOOD WORKBENCH

WW12 ASSEMBLY INSTRUCTIONS

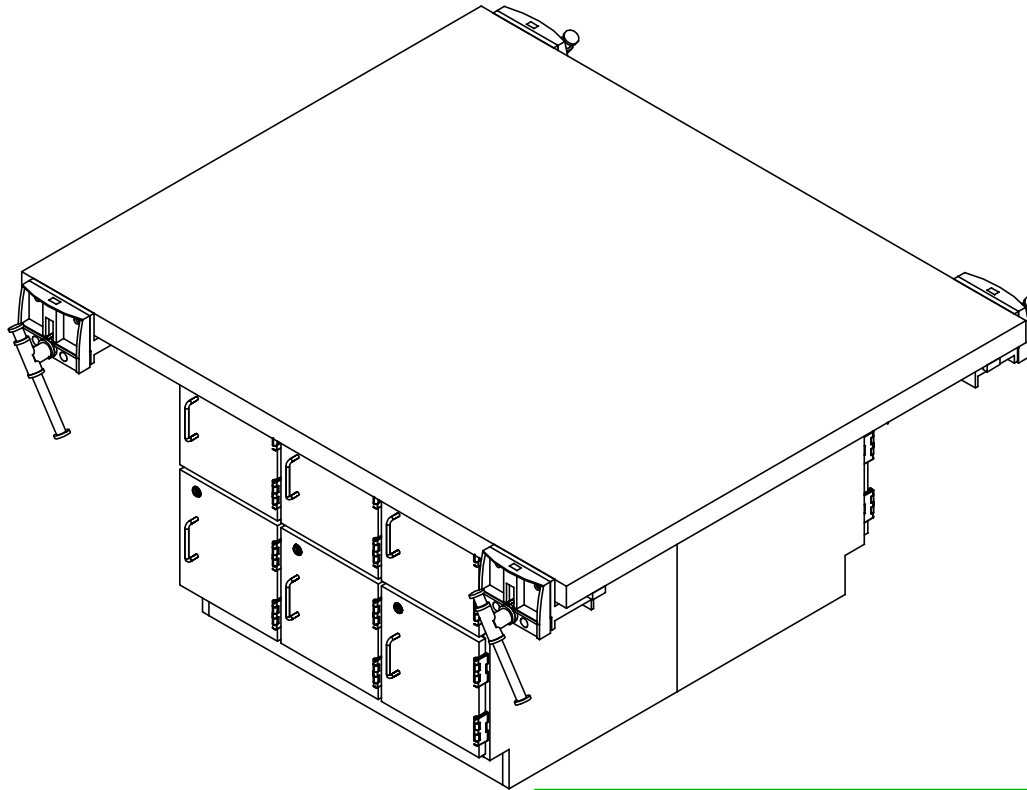

NOTE:

1. MODEL VIEWS MAY NOT REPRESENT EXACT MODEL PURCHASED

ALL DIMENSIONS ARE IN INCHES UNLESS NOTED OTHERWISE
 CABINET SQUARENESS = ± .0625
 PRACTICAL VALUES = ± 1/32"
 - ALL VALUES ± OVERALL -

DWN BY:	EMK	DATE DWN:	3/7/14
APR BY:		DATE APR:	
APR BY:		DATE APR:	

CONFIDENTIAL:
 ALL DESIGN RIGHTS RESERVED
 THE INFORMATION, DATA, DESIGN, AND DRAWINGS EMBODIED IN THIS DOCUMENT AND ALL REPRODUCTIONS THEREOF ARE THE EXCLUSIVE PROPERTY OF DIVERSIFIED WOODCRAFTS, INC.

THESE DOCUMENTS ARE SUPPLIED WITH THE UNDERSTANDING THAT THEY WILL NOT BE DISCLOSED TO THIRD PARTIES WITHOUT WRITTEN CONSENT OF DIVERSIFIED WOODCRAFTS, INC. ANY REPRODUCTION IN PART OR WHOLE WITHOUT WRITTEN CONSENT IS SUBJECT TO LEGAL ACTION.



300 South Krueger Street
 Suring, WI 54174
 diversifiedwoodcrafts.com

TITLE:
 WOOD WORKBENCH
 ASSEMBLY INSTRUCTIONS

REV.	DESCRIPTION	DATE	NAME	ECN NO.
A	CREATED ASSEMBLY INSTRUCTIONS	3/7/14	EMK	-

REVISION LEVEL

DRAWING NUMBER:

WW12

SCALE:

NTS

SHEET:

1 OF 10

REVISION:

REV A

TOOLS REQUIRED

CONTACT CEMENT

DRILL

ASSEMBLY COMPONENTS

ITEMS INCLUDED	PART #	PART DESCRIPTION	QTY
TOP	16-0052	TOP,MPL,2.25X54X64	1
SCREWS - TOP	100641	SCREW#8X1 $\frac{3}{4}$ "QUAD RD WASH HD	8
BASE CABINETS	N/A	BASE CABINETS - 36"W X 29"H X 22"D	2
CORNER BASE ASSEMBLY	206513	CORNER,BASE,ASSY,SST,2CORNERS W/ SCREWS	2
RUBBER BASE MOLDING	100283	RUBBER BASE MOLDING (SOLD BY FOOT)	12.66
GUSSET	253728	GUSSET,STEEL,12GAX8X8,ZINC PLATED	4
SCREWS - GUSSET	100037	SCREW,#10X5/8 QUAD PNHD LUB	24
WISE - OPTIONAL	234708	WISE-SHAIN CUSTOM WISE WITH LOGO	4

NOTE:

- COMPONENTS VARY WITH STYLE OF WOOD WORKBENCH PURCHASED.

ALL DIMENSIONS ARE IN INCHES UNLESS NOTED OTHERWISE	DWN BY: EMK	DATE DWN: 3/7/14
CABINET SQUARENESS = ± .0625	APR BY:	DATE APR:
FRACTIONAL VALUES = ± 1/32"	APR BY:	DATE APR:
- ALL VALUES ± OVERALL -		

CONFIDENTIAL:
ALL DESIGN RIGHTS RESERVED
THE INFORMATION, DATA, DESIGN, AND DRAWINGS EMBODIED IN THIS DOCUMENT AND ALL REPRODUCTIONS THEREOF ARE THE EXCLUSIVE PROPERTY OF DIVERSIFIED WOODCRAFTS, INC.

THESE DOCUMENTS ARE SUPPLIED WITH THE UNDERSTANDING THAT THEY WILL NOT BE DISCLOSED TO THIRD PARTIES WITHOUT WRITTEN CONSENT OF DIVERSIFIED WOODCRAFTS, INC. ANY REPRODUCTION IN PART OR WHOLE WITHOUT WRITTEN CONSENT IS SUBJECT TO LEGAL ACTION.



300 South Krueger Street
Suring, WI 54174
diversifiedwoodcrafts.com

TITLE:
WOOD WORKBENCH
TOOLS AND ASSEMBLY COMPONENTS

REV.	DESCRIPTION	DATE	NAME	ECN NO.
A	CREATED ASSEMBLY INSTRUCTIONS	3/7/14	EMK	-

REVISION LEVEL

DRAWING NUMBER:	SCALE:	SHEET:	REVISION:
WW12	NTS	2 OF 10	REV A

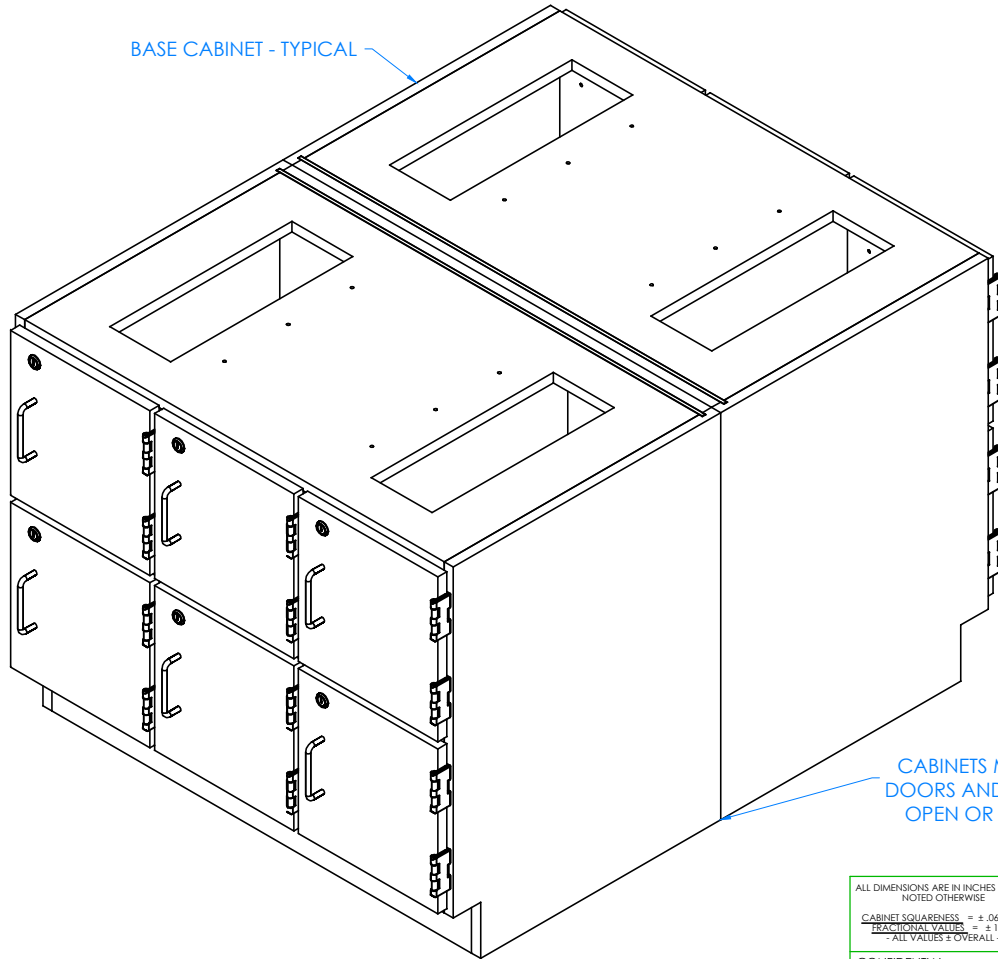

STEP 1:

- POSITION BASE CABINETS IN DESIRED LOCATION.
- LEVEL CABINETS.
- ANCHOR CABINETS TO EACH OTHER.

NOTE:

1.

ALL DIMENSIONS ARE IN INCHES UNLESS NOTED OTHERWISE	DWN BY: EMK	DATE DWN: 3/7/14
CABINET SQUARENESS = ± .0625	APR BY:	DATE APR:
FRACTURAL VALUES = ± 1/32"	APR BY:	DATE APR:
- ALL VALUES ± OVERALL -		

CONFIDENTIAL:
 ALL DESIGN RIGHTS RESERVED
 THE INFORMATION, DATA, DESIGN, AND DRAWINGS EMBODIED IN THIS DOCUMENT AND ALL REPRODUCTIONS THEREOF ARE THE EXCLUSIVE PROPERTY OF DIVERSIFIED WOODCRAFTS, INC.

THESE DOCUMENTS ARE SUPPLIED WITH THE UNDERSTANDING THAT THEY WILL NOT BE DISCLOSED TO THIRD PARTIES WITHOUT WRITTEN CONSENT OF DIVERSIFIED WOODCRAFTS, INC. ANY REPRODUCTION IN PART OR WHOLE WITHOUT WRITTEN CONSENT IS SUBJECT TO LEGAL ACTION.



300 South Krueger Street
 Suring, WI 54174
 diversifiedwoodcrafts.com

TITLE:
 WOOD WORKBENCH
 ASSEMBLY INSTRUCTIONS

REV.	DESCRIPTION	DATE	NAME	ECN NO.
A	CREATED ASSEMBLY INSTRUCTIONS	3/7/14	EMK	-
REVISION LEVEL				

DRAWING NUMBER:	SCALE:	SHEET:	REVISION:
WW12	NTS	3 OF 10	REV A

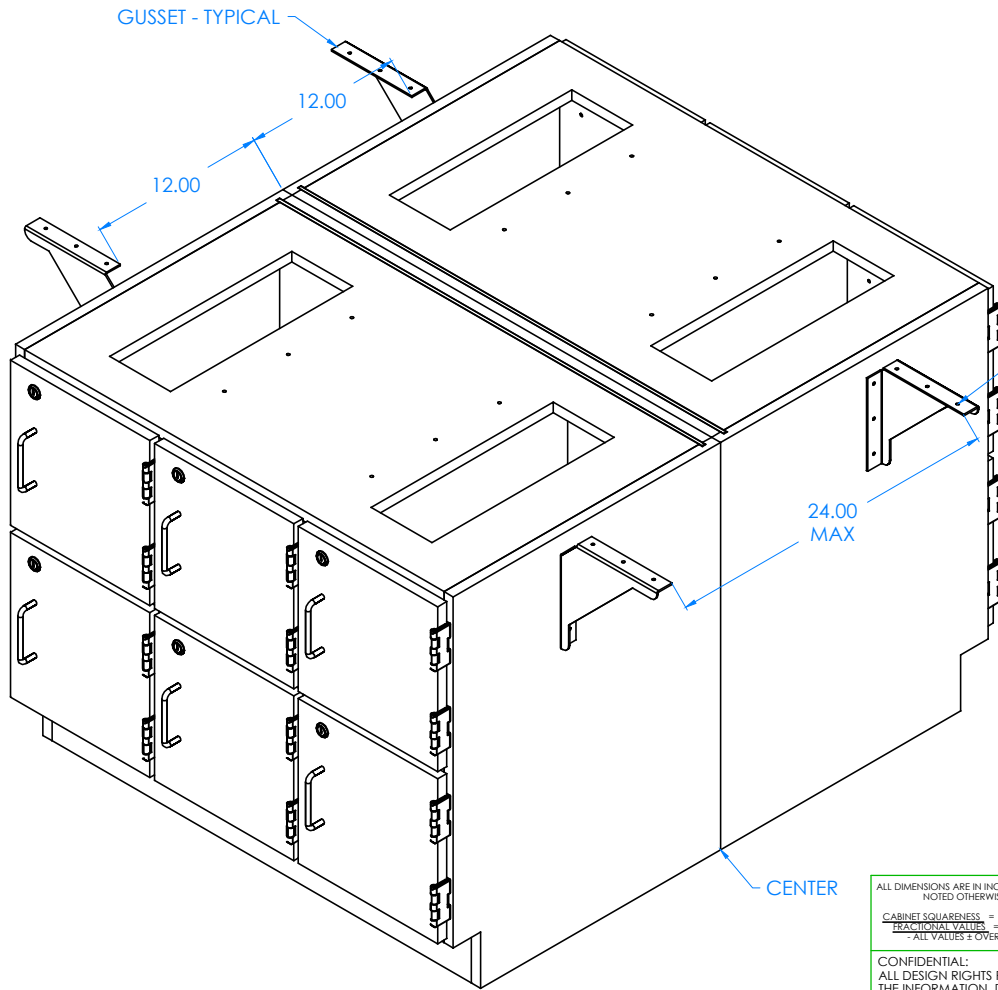

STEP 2:

- PLACE GUSSETS 12" TOWARDS FRONT OF WORKBENCH FOR A TOTAL OF 24" IN BETWEEN.
- TOP EDGE OF GUSSET SHOULD BE FLUSH WITH TOP EDGE OF CABINETS.
- ATTACH STEEL GUSSETS TO CABINETS WITH HARDWARE PROVIDED.
- PRE-DRILL HOLES IN SIDES TO PREVENT CRACKING.
- MAKE SURE SCREWS ARE TIGHT AND GUSSETS ARE SECURE.

****NOTE****
THE EDGE OF GUSSETS WITH THROUGH HOLES SHOULD BE FACING EACH OTHER.

NOTE:

1.

ALL DIMENSIONS ARE IN INCHES UNLESS NOTED OTHERWISE			
DWN BY:	EMK	DATE DWN:	3/7/14
APR BY:		DATE APR:	
APR BY:		DATE APR:	

CONFIDENTIAL:
ALL DESIGN RIGHTS RESERVED
THE INFORMATION, DATA, DESIGN, AND DRAWINGS EMBODIED IN THIS DOCUMENT AND ALL REPRODUCTIONS THEREOF ARE THE EXCLUSIVE PROPERTY OF DIVERSIFIED WOODCRAFTS, INC.

THESE DOCUMENTS ARE SUPPLIED WITH THE UNDERSTANDING THAT THEY WILL NOT BE DISCLOSED TO THIRD PARTIES WITHOUT WRITTEN CONSENT OF DIVERSIFIED WOODCRAFTS, INC. ANY REPRODUCTION IN PART OR WHOLE WITHOUT WRITTEN CONSENT IS SUBJECT TO LEGAL ACTION.



300 South Krueger Street
Suring, WI 54174
diversifiedwoodcrafts.com

TITLE:
WOOD WORKBENCH
ASSEMBLY INSTRUCTIONS

REV.	DESCRIPTION	DATE	NAME	ECN NO.
A	CREATED ASSEMBLY INSTRUCTIONS	3/7/14	EMK	-

REVISION LEVEL

DRAWING NUMBER:	SCALE:	SHEET:	REVISION:
WW12	NTS	4 OF 10	REV A

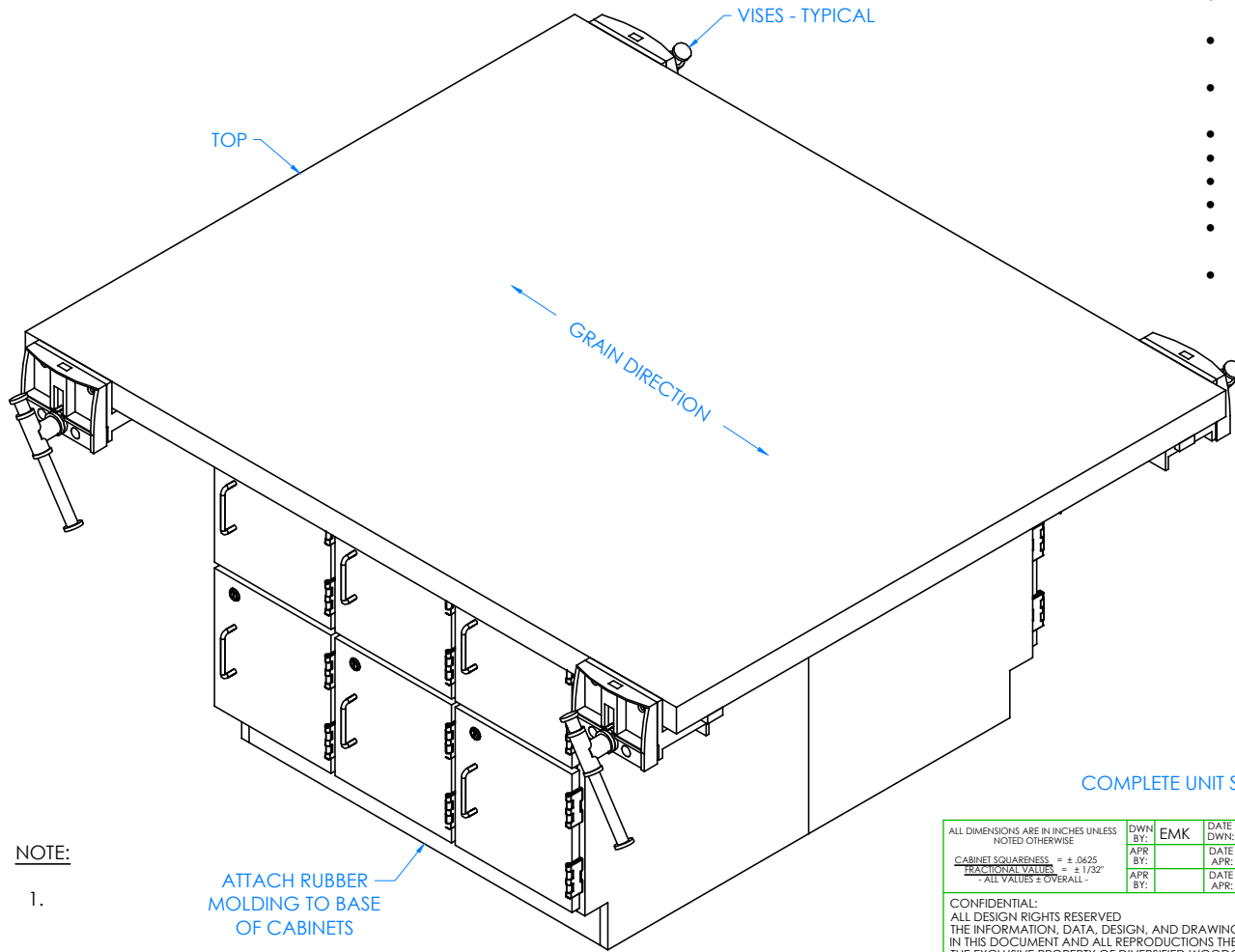

STEP 3:

- PLACE TOP ON CABINETS WITH PROPER OVERHANG (CENTERED ON WORKBENCH) AND GRAIN DIRECTION CORRECT WAY.
- ATTACH TOP TO CABINETS AND GUSSETS WITH HARDWARE PROVIDED.
- SCREW THROUGH INSIDE OF CABINETS TO THE TOP.
- PRE-DRILL HOLES IN TOP TO PREVENT CRACKING.
- MAKE SURE SCREWS ARE TIGHT AND TOP IS SECURE.
- ATTACH RUBBER MOLDING TO BASE USING CONTACT CEMENT.
- SCREW STAINLESS STEEL CORNER BRACKETS ON EACH CORNER OVER BASE MOLDING WITH HARDWARE PROVIDED.
- ATTACH VISES IF INCLUDED.

COMPLETE UNIT SHOWN

NOTE:

1.

ATTACH RUBBER MOLDING TO BASE OF CABINETS

ALL DIMENSIONS ARE IN INCHES UNLESS NOTED OTHERWISE	DWN BY: EMK	DATE DWN: 3/7/14
CABINET SQUARENESS = ± .0625	APR BY:	DATE APR:
FRACTURAL VALUES = ± 1/32"	APR BY:	DATE APR:
- ALL VALUES ± OVERALL -		

CONFIDENTIAL:
ALL DESIGN RIGHTS RESERVED
THE INFORMATION, DATA, DESIGN, AND DRAWINGS EMBODIED IN THIS DOCUMENT AND ALL REPRODUCTIONS THEREOF ARE THE EXCLUSIVE PROPERTY OF DIVERSIFIED WOODCRAFTS, INC.

THESE DOCUMENTS ARE SUPPLIED WITH THE UNDERSTANDING THAT THEY WILL NOT BE DISCLOSED TO THIRD PARTIES WITHOUT WRITTEN CONSENT OF DIVERSIFIED WOODCRAFTS, INC. ANY REPRODUCTION IN PART OR WHOLE WITHOUT WRITTEN CONSENT IS SUBJECT TO LEGAL ACTION.



300 South Krueger Street
Suring, WI 54174
diversifiedwoodcrafts.com

TITLE: WOOD WORKBENCH ASSEMBLY INSTRUCTIONS

DRAWING NUMBER: WW12	SCALE: NTS	SHEET: 5 OF 10	REVISION: REV A
----------------------	------------	----------------	-----------------

REV.	DESCRIPTION	DATE	NAME	ECN NO.
A	CREATED ASSEMBLY INSTRUCTIONS	3/7/14	EMK	-
REVISION LEVEL				

Warning:

Misuse of vises can cause serious injury to eyes, hands and or other body parts. Vises must be set up and used properly. Before setup and use, read, understand and follow all instructions outlined.

ALWAYS make sure bench tops are properly secured.

Never use a hammer, extension pipe, or cheater bar on spindle handle of vise.

ALWAYS use proper mounting hardware in all mounting holes to hold vise securely.

NEVER unscrew movable jaw beyond maximum specified opening of vise.

ALWAYS inspect mounting hardware to ensure vise is securely fastened to work bench.

NEVER weld vise to any metal object.

ALWAYS inspect vise for stress fatigue or damage to the vise before using.

NEVER use a vise to press an object into or out of another object.

ALWAYS use vise of proper size and capacity to hold work object.

NEVER place pressurized containers or combustible materials in vise.

ALWAYS wear eye, face, and ear protection when using a vise.

NEVER wear loose clothing or jewelry while operating vise.

ALWAYS wear dust mask or respirator when working with wood, metal, chemical dusts or mists.

NEVER apply extreme heat or prolong heat to the vise as it may alter structural properties.

ALWAYS rest work piece against front jaw and guide rods.

NEVER tighten work piece at the edge (top or side) of the vise as this may break vise casting

ALWAYS wear restrictive hair covering and anti slip footwear while operating vise.

ALWAYS only hand tighten vise.

ALWAYS maintain the vise – grease main screw regularly.

Mount Back Jaw Casting to Workbench

- Pre-drill holes for mounting screws using template provided. Be sure to drill holes straight and deep enough to accommodate the full length of the screw. Use recommended drill sizes only (see template provided).
- It is **CRITICAL** that the back jaw casting is mounted firmly and accurately to the workbench surface. **NO GAPS** between the casting and the workbench should be present. Use shims as needed. Refer to figure #1 below.
- **DO NOT** attach the vise to the end grain side of the workbench. By attaching the vise to the side grain side of the workbench the mounting screw will have a much stronger hold.
- When attaching the back jaw casting to the workbench, take care to ensure there is full contact of the casting to the workbench surface before tightening the mounting screws.
- The vertical portion of the back jaw against the front edge of the workbench and the horizontal portion of the casting on the underside of the bench must have full contact with the workbench. Use shims to eliminate any gaps that may be present.
- Any gaps between the casting and the workbench surface will cause flexing of the casting when tightened down, which could result in failure of the casting. Figure 1.
- **MOUNTING HARDWARE:** Use the #14 x 1-1/2" Counter-Sink Wood Screws (2) for the front edge mounting holes and the 5/16" x 2-1/2" Lag Screws (2) and the 5/16" Flat Washers (2) for underneath the workbench

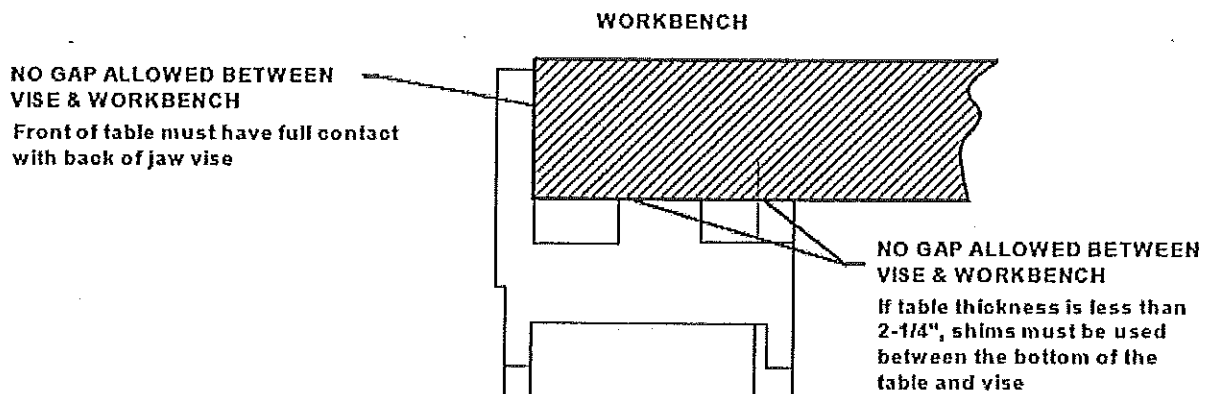
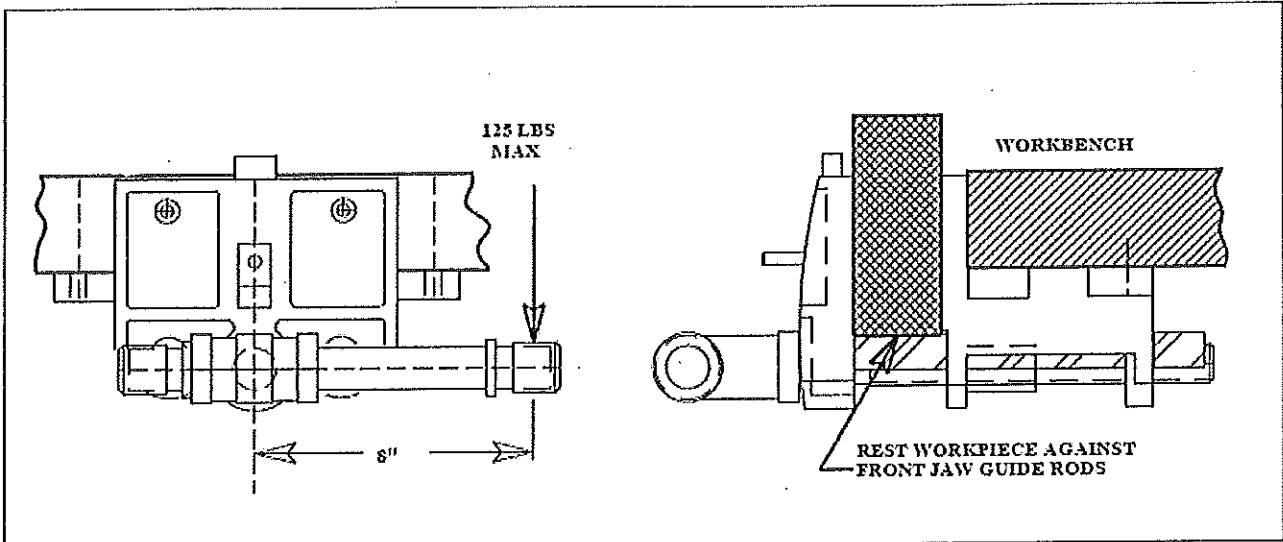
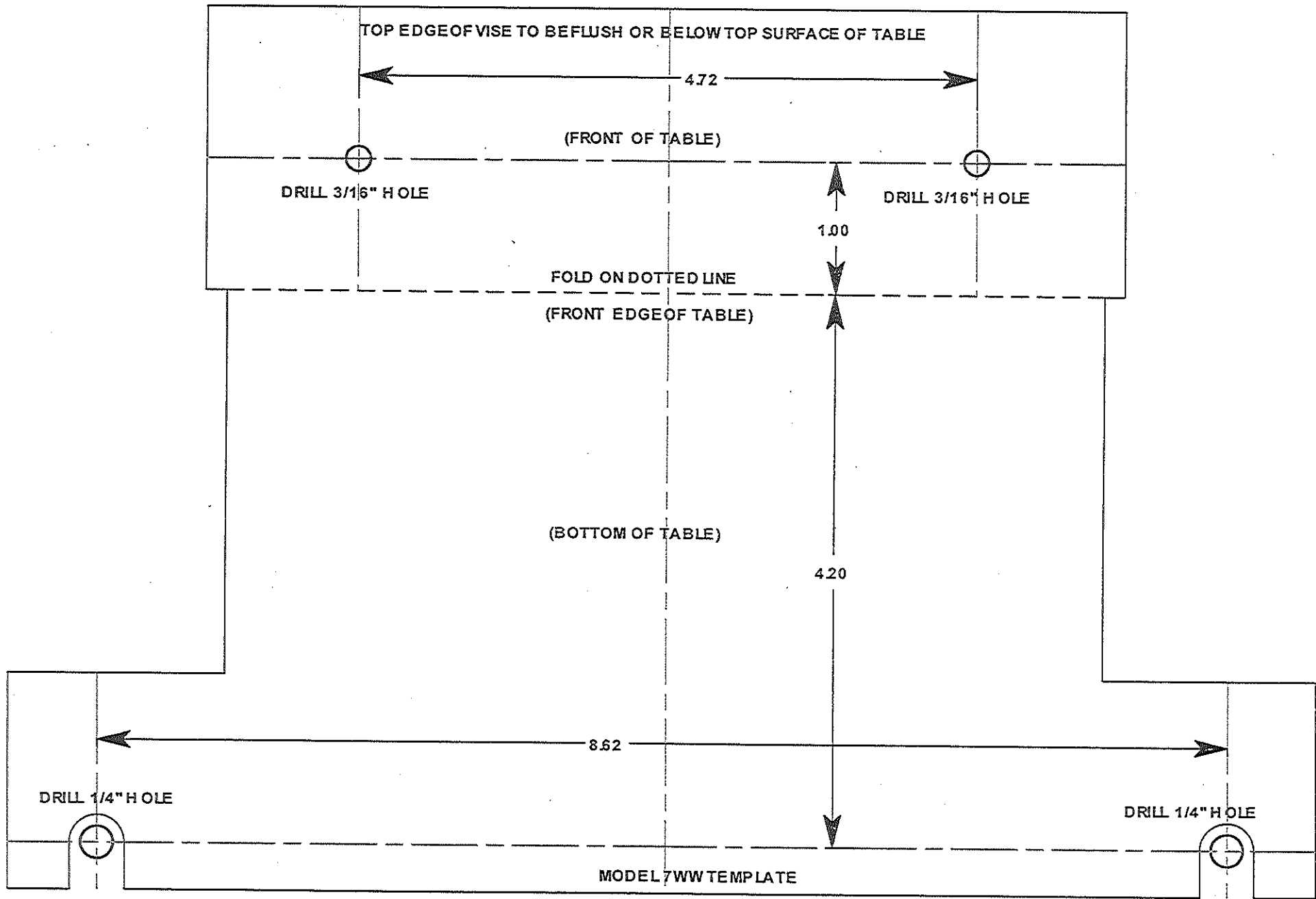

Figure 1: Mount Back Jaw Casting to Work Bench

Caution:

Do not exceed the maximum applied torque of 1,000 inch-pounds (125 foot-pounds). Also, failure to rest work piece against the front jaw and the guide rods may also cause the castings to flex resulting in failure. See Figure 2.





Butcher Block (Varnished Tops) *Maintenance & Repair*

SPILLS

- Be sure any spills are cleaned up immediately. Excessive moisture and certain chemicals allowed to stand on a finished surface can cause damage.
- Clean spills or soiled areas with a damp cloth and dry thoroughly.
- Periodically, apply a coat of spray wax, paste wax, or lemon oil to finished surface. This will enhance and protect the finish and insure a moisture barrier is intact in the event the finish becomes scratched or worn.

SCRATCHES & DENTS

- Minor scratches and dents can be easily repaired by rubbing the affected area with steel wool or fine grit (#220) sandpaper. Remember, when rubbing or sanding always sand with the grain of the wood. Feather edges of repair in to the surrounding area. Remove all dust and residue and apply a coat of clear lacquer type finish or paint. Clear lacquer type finish can be purchased at most paint or hardware stores. Small cans of touch-up paint are available from your dealer or representative. Paint colors can easily be matched at most paint stores. Confine touch-up only to the area that was sanded. Remember, follow manufacturing directions on product label when refinishing.
- Major scratches and gouges where large portions of wood have been removed or damaged should be handled by a professional experienced in furniture repair with the proper tools and equipment.

MINERAL STREAKS

- Mineral Streaks—Natural Coloring of wood due to mineral deposits in the tree. Repair is not required and will add to the individuality of your table. Sizes can range up to a 1/4" wide and up to 3" in length.

HUMIDITY GUIDELINES

Your Butcher Block was kiln-dried to an initial moisture content of 7.6%. In order to maintain the beauty and integrity of your Butcher Block, it is recommended that special care be taken to keep the relative humidity and temperature within your home or warehouse in the highlighted range. This will limit the amount of expansion and contraction in your natural wood product and minimize the risk of environmental damage.

- **Environment Acclimation:** Environmental damage does not constitute defective product. Allowing your Butcher Block to acclimate to the environment for at least 72 hours prior to installation, following recommended installation practices that allow your Butcher Block to move with the conditions and controlling the environment itself are all key factors that determine the life of your product.
- **Temperature Changes:** It is important to note that as winter temperatures drop, so does relative humidity in the air. The heaters come on which further dries the air. Keeping the area humidified to an acceptable level usually becomes necessary during the winter months. The opposite is true in spring and summer as humidity rises, dehumidifiers and air conditioners become the method of control.

		RELATIVE HUMIDITY %																	
		5	10	15	20	25	30	35	40	45	50	55	60	65	70	75	80	85	90
TEMPERATURE (°F)	30	1.4	2.6	3.7	4.6	5.5	6.3	7.1	7.8	8.7	9.5	10.4	11.3	12.4	13.5	14.9	17	18.5	21
	40	1.4	2.6	3.7	4.6	5.5	6.3	7.1	7.8	8.7	9.5	10.4	11.3	12.4	13.5	14.9	17	18.5	21
	50	1.4	2.6	3.6	4.6	5.5	6.3	7.1	7.9	8.7	9.5	10.3	11.2	12.3	13.4	14.8	16	18.4	20.9
	60	1.3	2.5	3.6	4.6	5.4	6.2	7	7.8	8.6	9.4	10.2	11.1	12.1	13.3	14.6	16	18.2	20.7
	70	1.3	2.5	3.5	4.5	5.4	6.2	6.9	7.7	8.5	9.2	10.1	11	12	13.1	14.4	16	17.9	20.5
	80	1.3	2.4	3.5	4.4	5.3	6.1	6.8	7.6	8.3	9.1	9.9	10.8	11.7	12.9	14.2	16	17.7	20.2
	90	1.2	2.3	3.4	4.3	5.1	5.9	6.7	7.4	8.1	8.9	9.7	10.5	11.85	12.6	13.9	15	17.3	19.8
	100	1.2	2.3	3.3	4.2	5	5.8	6.5	7.2	7.9	8.7	9.5	10.3	11.2	12.3	13.6	15	17	19.5

Example: If conditions in a warehouse are 60% relative humidity at 50 degrees Fahrenheit Dry wood will pick up moisture until 11.2% is reached, regardless of wood species and initial moisture content.