

# OCTAGON WORKSTATION W/ PEDESTAL

1514, 1514F, 1516, 1516F, 1614, 1614F, 1616, & 1616F SERIES  
ASSEMBLY INSTRUCTIONS

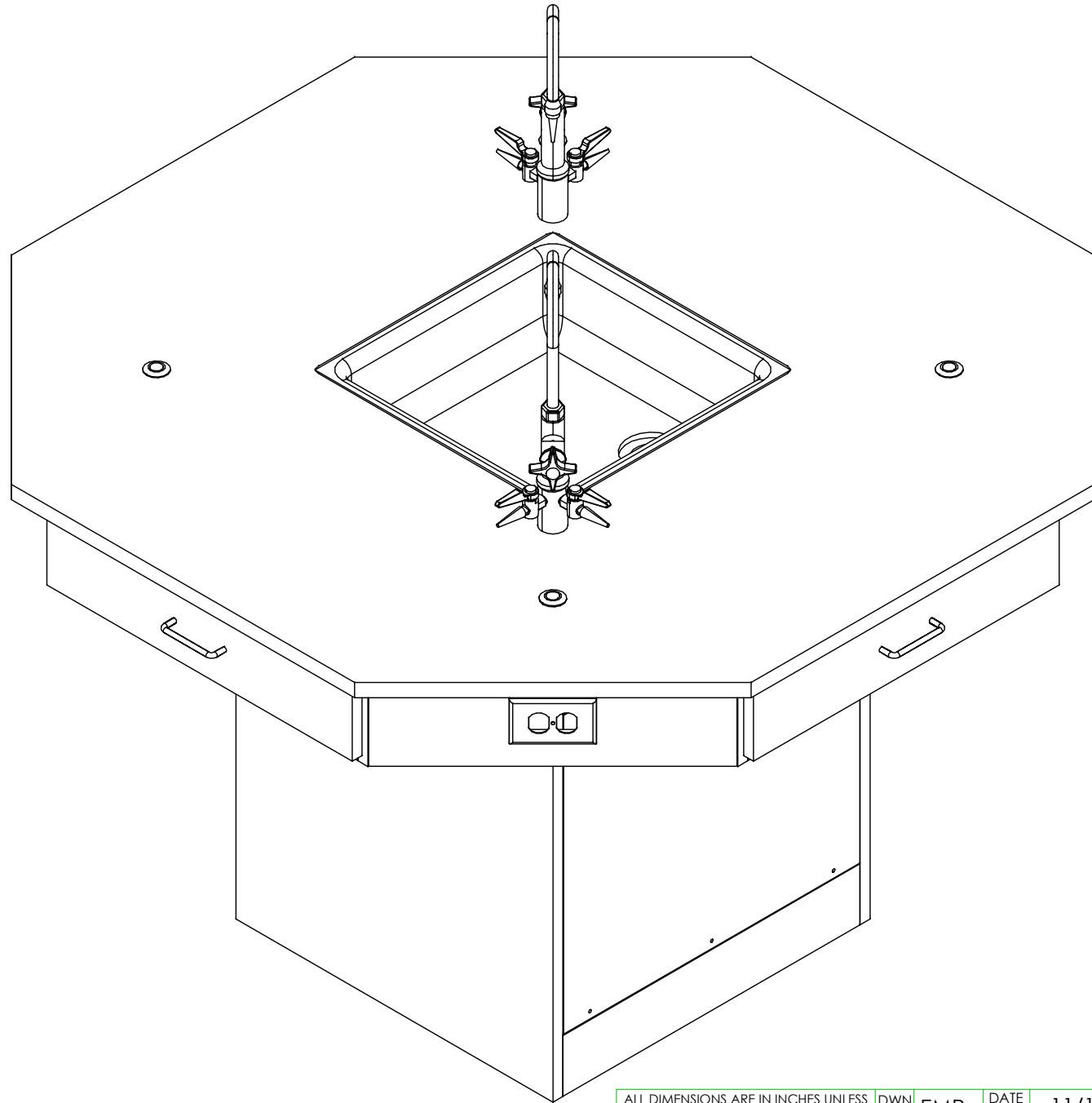

**NOTE:**

1. MODEL VIEWS MAY NOT REPRESENT EXACT MODEL PURCHASED

ALL DIMENSIONS ARE IN INCHES UNLESS NOTED OTHERWISE  
 DECIMALS: .X = ± .030  
 .XX = ± .020  
 .XXX = ± .010  
 ANGLES: = ± 1°  
 CABINET SQUARENESS = ± .0625

DWN BY:	EMR	DATE DWN:	11/16/16
APR BY:		DATE APR:	
APR BY:		DATE APR:	



300 South Krueger Street  
Suring, WI 54174  
diversifiedwoodcrafts.com

CONFIDENTIAL:  
 ALL DESIGN RIGHTS RESERVED.  
 THE INFORMATION, DATA, DESIGN, AND DRAWINGS EMBODIED IN THIS DOCUMENT AND ALL REPRODUCTIONS THEREOF ARE THE EXCLUSIVE PROPERTY OF DIVERSIFIED WOODCRAFTS, INC.

TITLE:  
**OCTAGON WORKSTATION W/ PEDESTAL ASSEMBLY INSTRUCTIONS**

THESE DOCUMENTS ARE SUPPLIED WITH THE UNDERSTANDING THAT THEY WILL NOT BE DISCLOSED TO THIRD PARTIES WITHOUT WRITTEN CONSENT OF DIVERSIFIED WOODCRAFTS, INC. ANY REPRODUCTION IN PART OR WHOLE WITHOUT WRITTEN CONSENT IS SUBJECT TO LEGAL ACTION.

REV.	DESCRIPTION	DATE	NAME	ECN NO.
C	UPDATED SILICONE PROCEDURE	8/18/23	RJM	-
A	CREATED DRAWING	11/16/16	EMR	-
REVISION LEVEL				

DRAWING NUMBER:	SCALE:	SHEET:	REVISION:
<b>OCTAGON WORKSTATION</b>	NTS	1 OF 9	REV C

# TOOLS REQUIRED

CONTACT CEMENT
SCREW DRIVER
C-CLAMPS
SHIM STOCK (IF NEEDED)

# ASSEMBLY COMPONENTS

ITEMS INCLUDED	PART #	PART DESCRIPTION	QTY
TOP	VARIES	TOP (STYLE VARIES), 1.00X56X56,BLK, (FIXTURE OR FLAT) <u>OR</u> 1.00X62X62	1
PEDESTAL	N/A	PEDESTAL - 24"W X 29"H X 24"D <u>OR</u> 30"W X 29"H X 30"D	1
APRON ASSEMBLY	N/A	APRON ASSEMBLY (FACTORY ASSEMBLED)	1
SCREWS - ATTACHMENT BOARDS	100378	SCREW,#8.00X1 ¼ FLAT SQUARE HEAD	6
SILICONE	100711	SILICONE,SEALANT,CLEAR	1
RUBBER BASE MOLDING	100283	RUBBER BASE MOLDING (SOLD BY FOOT)	VARIES
STAINLESS STEEL CORNERS	100057	CORNERS-STAINLESS STEEL,BASE	4
SCREWS - BASE	100064	SCREW,#6X½ PTH SMS SS SCREW	16
ELECTRICAL BOX	100033	ELECTRICAL BOX 3.00X2X2.5 DEEP	4
ELECTRICAL OUTLET	100034	ELEC,OUTLET,GFI,20A 125V,BLK	4
**FIXTURE - FAUCET**	100074-BKR	FIXTURE,L65-WSA-DIV (MULTI-SERVICE)	2
**FIXTURE - SINK**	100697	SINK,EPOXY L20, BLK	1
**FIXTURE - SINK TRAP**	100056	SINK TRAP, PLASTIC ADJUSTABLE	1
**FIXTURE - SINK OUTLET/STRAINER**	254047	SINK OUTLET TAIL PIECE/INTEGRAL STRAINER,BLK	1
**ROD SOCKETS**	206505	ROD SOCKET ASSY,SOCKET,WASHER,NUT	4

**NOTE:**

- TOPS ARE EITHER PHENOLIC OR EPOXY.
- TOPS AND PEDESTALS VARY IN SIZE WITH STYLE OF WORKSTATION PURCHASED.
  - EX. 1510/F OR 1610/F
- \*\*XX\*\* INDICATES ITEMS USED ONLY FOR UNITS WITH A SINK OR FIXTURES.

REV.	DESCRIPTION	DATE	NAME	ECN NO.
C	UPDATED SILICONE PROCEDURE	8/18/23	RJM	-
A	CREATED DRAWING	11/16/16	EMR	-
REVISION LEVEL				

ALL DIMENSIONS ARE IN INCHES UNLESS NOTED OTHERWISE DECIMALS: .X = ± .030 .XX = ± .020 .XXX = ± .010 ANGLES: = ± 1° CABINET SQUARENESS = ± .0625	DWN BY: EMR APR BY: APR BY:	DATE DWN: 11/16/16 DATE APR: DATE APR:
---	-----------------------------------	--

CONFIDENTIAL:  
ALL DESIGN RIGHTS RESERVED  
THE INFORMATION, DATA, DESIGN, AND DRAWINGS EMBODIED IN THIS DOCUMENT AND ALL REPRODUCTIONS THEREOF ARE THE EXCLUSIVE PROPERTY OF DIVERSIFIED WOODCRAFTS, INC.

THESE DOCUMENTS ARE SUPPLIED WITH THE UNDERSTANDING THAT THEY WILL NOT BE DISCLOSED TO THIRD PARTIES WITHOUT WRITTEN CONSENT OF DIVERSIFIED WOODCRAFTS, INC. ANY REPRODUCTION IN PART OR WHOLE WITHOUT WRITTEN CONSENT IS SUBJECT TO LEGAL ACTION.



300 South Krueger Street  
Suring, WI 54174  
diversifiedwoodcrafts.com

TITLE:  
OCTAGON WORKSTATION W/ PEDESTAL TOOLS AND ASSEMBLY COMPONENTS

DRAWING NUMBER:	SCALE:	SHEET:	REVISION:
OCTAGON WORKSTATION	NTS	2 OF 9	REV C

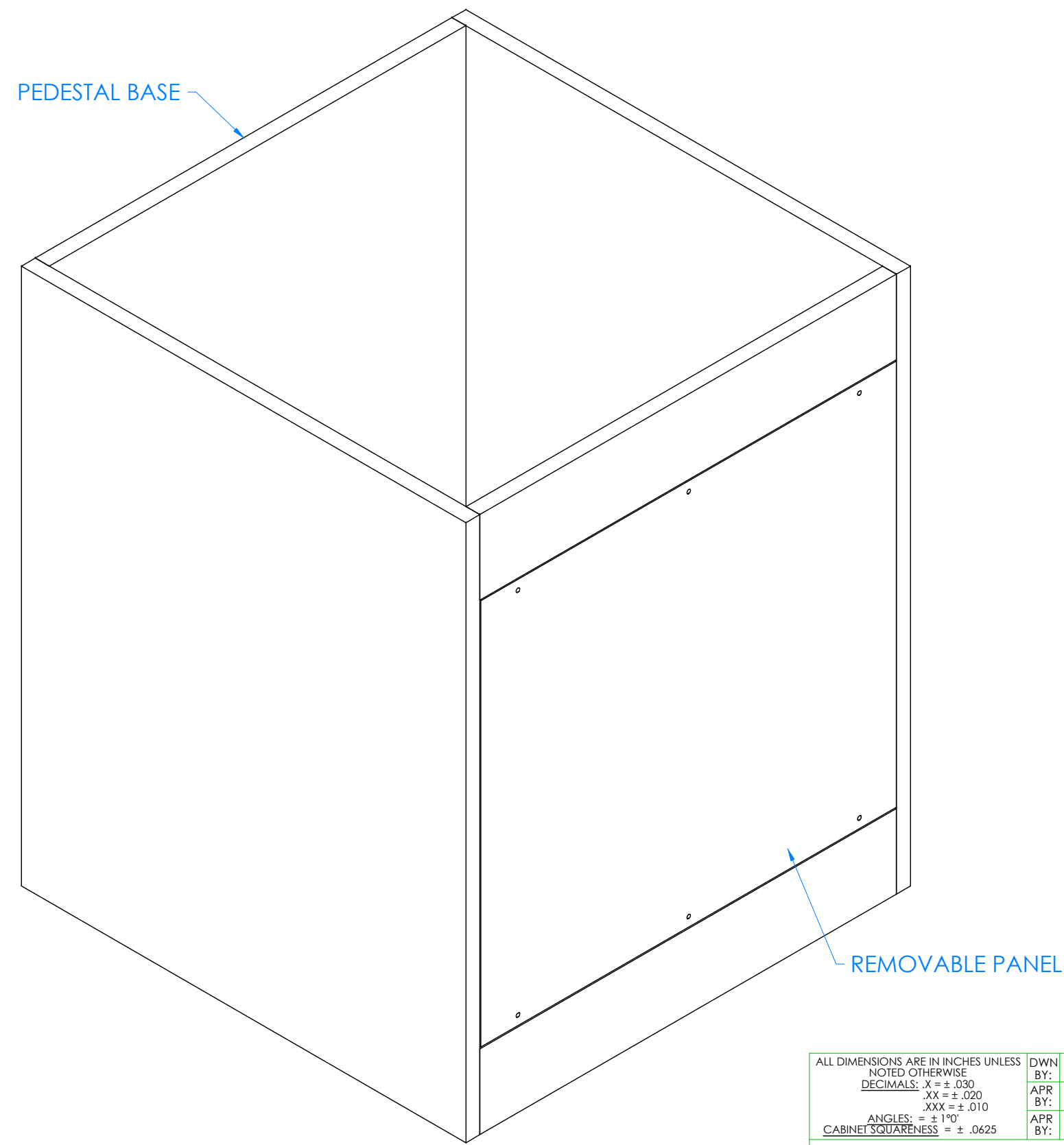

HARDWARE REQUIRED FOR STEP		
QTY	DESCRIPTION	PART NUMBER
1	PEDESTAL	N/A

STEP 1:

- a. POSITION PEDESTAL BASE IN DESIRED LOCATION.
- b. IF YOU HAVE A UNIT WITH A SINK/FIXTURES, PLACE BASE OVER UTILITY HOOKUPS.
- c. THERE IS A REMOVABLE PANEL ON ONE SIDE OF PEDESTAL THAT WILL ALLOW ACCESS TO THE UTILITIES IN FUTURE.
- d. LEVEL PEDESTAL.
- e. ATTACH TO FLOOR.

NOTE:

1.

REV.	DESCRIPTION	DATE	NAME	ECN NO.
C	UPDATED SILICONE PROCEDURE	8/18/23	RJM	-
A	CREATED DRAWING	11/16/16	EMR	-

REVISION LEVEL

ALL DIMENSIONS ARE IN INCHES UNLESS NOTED OTHERWISE DECIMALS: .X = ± .030 .XX = ± .020 .XXX = ± .010 ANGLES: = ± 1° CABINET SQUARENESS = ± .0625	DWN BY: EMR APR BY: APR BY:	DATE DWN: 11/16/16 DATE APR: DATE APR:
---	-----------------------------------	--

CONFIDENTIAL:  
ALL DESIGN RIGHTS RESERVED  
THE INFORMATION, DATA, DESIGN, AND DRAWINGS EMBODIED IN THIS DOCUMENT AND ALL REPRODUCTIONS THEREOF ARE THE EXCLUSIVE PROPERTY OF DIVERSIFIED WOODCRAFTS, INC.

THESE DOCUMENTS ARE SUPPLIED WITH THE UNDERSTANDING THAT THEY WILL NOT BE DISCLOSED TO THIRD PARTIES WITHOUT WRITTEN CONSENT OF DIVERSIFIED WOODCRAFTS, INC. ANY REPRODUCTION IN PART OR WHOLE WITHOUT WRITTEN CONSENT IS SUBJECT TO LEGAL ACTION.



300 South Krueger Street  
Suring, WI 54174  
diversifiedwoodcrafts.com

TITLE:  
**OCTAGON WORKSTATION W/ PEDESTAL ASSEMBLY INSTRUCTIONS**

DRAWING NUMBER:	SCALE:	SHEET:	REVISION:
<b>OCTAGON WORKSTATION</b>	NTS	3 OF 9	REV C

ATTACHMENT BOARDS - TYPICAL  
ATTACH APRON ASSEMBLY ONTO  
PEDESTAL BASE THROUGH THESE  
ATTACHMENT BOARDS

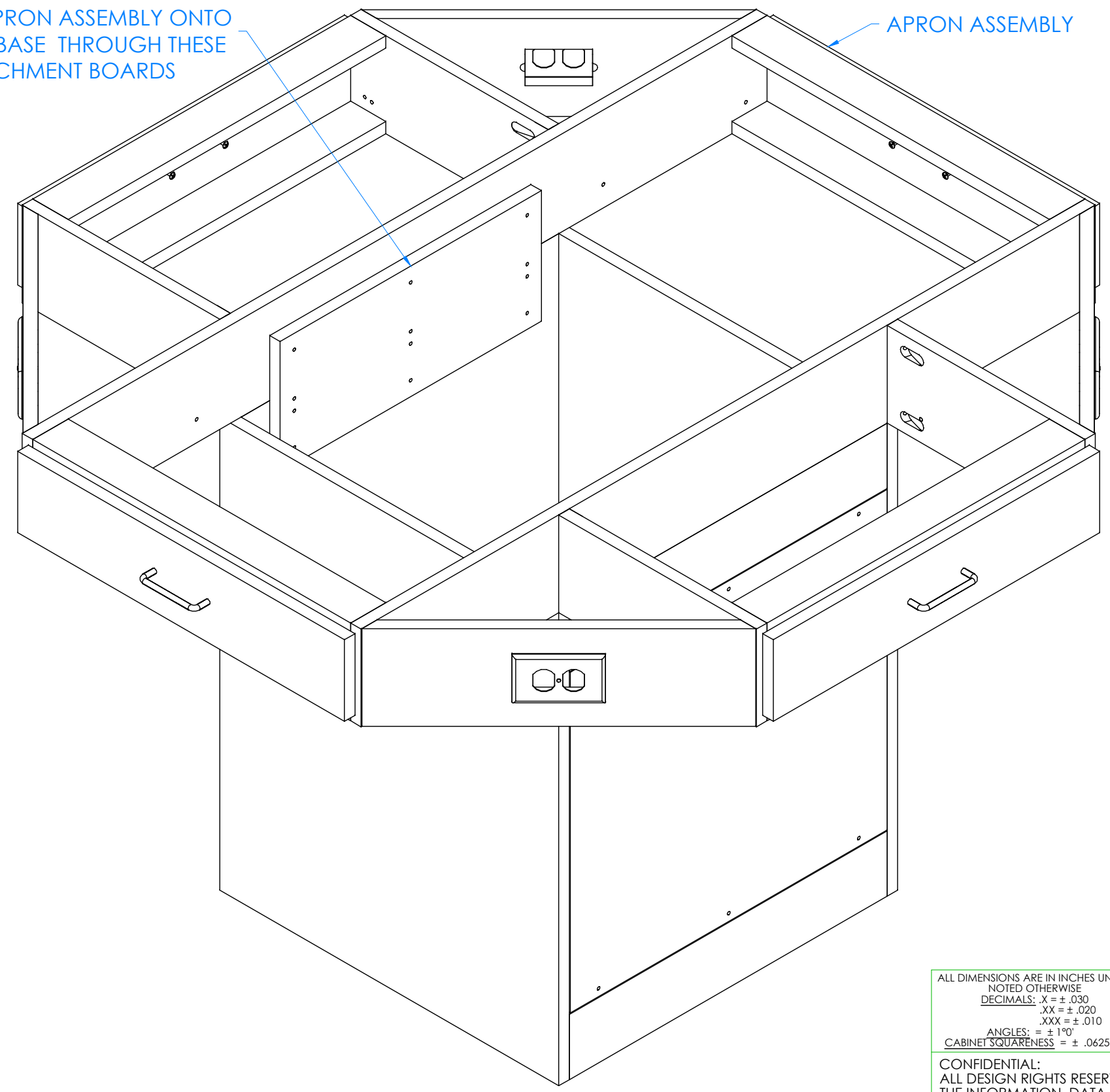

### HARDWARE REQUIRED FOR STEP

QTY	DESCRIPTION	PART NUMBER
1	APRON ASSEMBLY	N/A
6	SCREWS - ATTACHMENT BOARDS	100378

STEP 2:

- a. WITH HELP FROM ANOTHER PERSON, SET APRON ASSEMBLY ON PEDESTAL BASE WITH ATTACHMENT BOARDS SET INSIDE OF BASE.
- b. SCREW APRON ASSEMBLY ONTO PEDESTAL THROUGH ATTACHMENT BOARDS USING PROVIDED HARDWARE LISTED ABOVE.

NOTE:

1.

ALL DIMENSIONS ARE IN INCHES UNLESS NOTED OTHERWISE DECIMALS: .X = ± .030 .XX = ± .020 .XXX = ± .010 ANGLES: = ± 1° CABINET SQUARENESS = ± .0625	DWN BY: EMR APR BY: APR BY:	DATE DWN: 11/16/16 DATE APR: DATE APR:
---	-----------------------------------	--



300 South Krueger Street  
Suring, WI 54174  
diversifiedwoodcrafts.com

CONFIDENTIAL:  
ALL DESIGN RIGHTS RESERVED  
THE INFORMATION, DATA, DESIGN, AND DRAWINGS EMBODIED IN THIS DOCUMENT AND ALL REPRODUCTIONS THEREOF ARE THE EXCLUSIVE PROPERTY OF DIVERSIFIED WOODCRAFTS, INC.

TITLE:  
OCTAGON WORKSTATION W/ PEDESTAL  
ASSEMBLY INSTRUCTIONS

THESE DOCUMENTS ARE SUPPLIED WITH THE UNDERSTANDING THAT THEY WILL NOT BE DISCLOSED TO THIRD PARTIES WITHOUT WRITTEN CONSENT OF DIVERSIFIED WOODCRAFTS, INC. ANY REPRODUCTION IN PART OR WHOLE WITHOUT WRITTEN CONSENT IS SUBJECT TO LEGAL ACTION.

DRAWING NUMBER:	SCALE:	SHEET:	REVISION:
OCTAGON WORKSTATION	NTS	4 OF 9	REV C

REV.	DESCRIPTION	DATE	NAME	ECN NO.
C	UPDATED SILICONE PROCEDURE	8/18/23	RJM	-
A	CREATED DRAWING	11/16/16	EMR	-

REVISION LEVEL

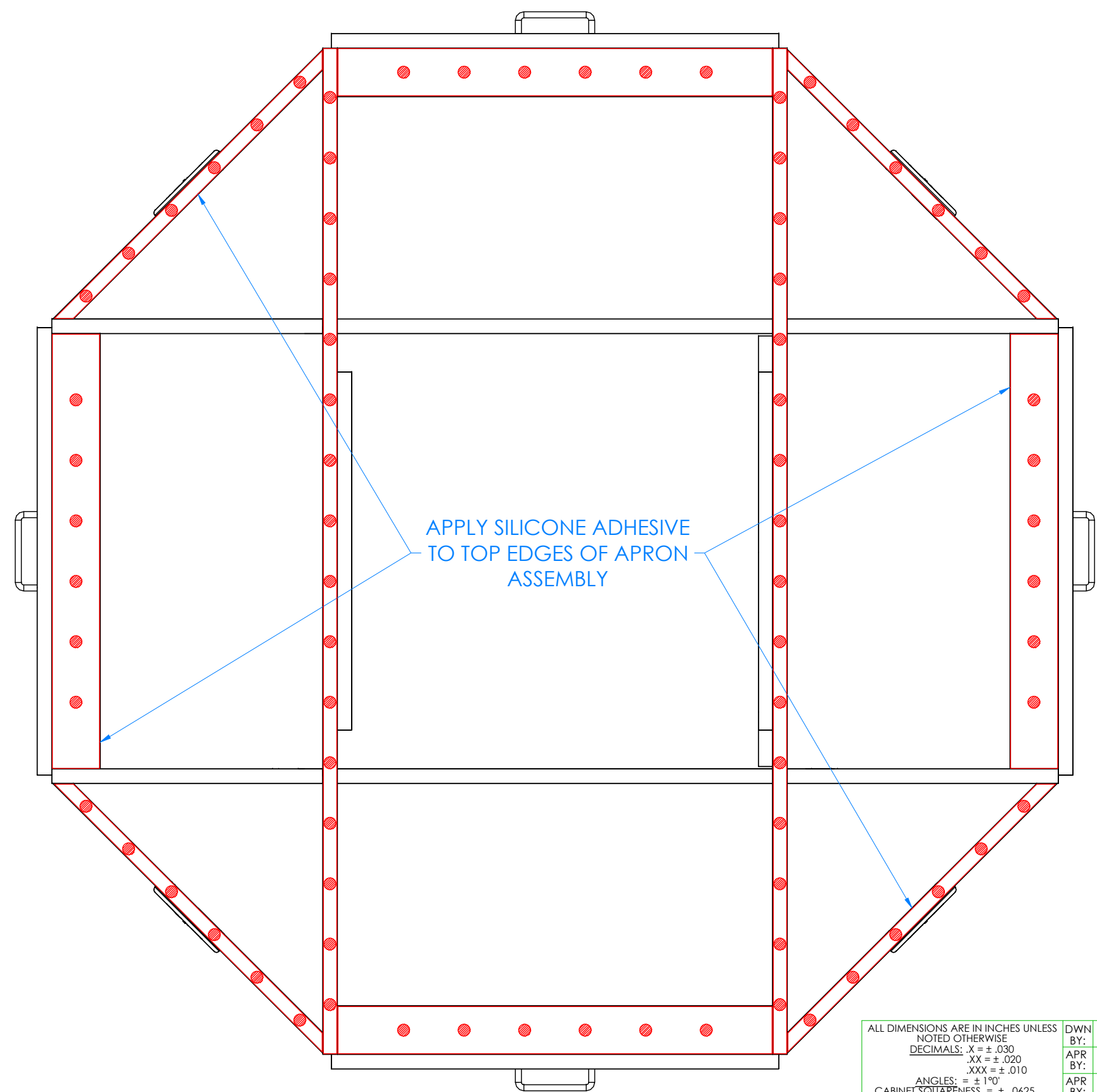

### HARDWARE REQUIRED FOR STEP

QTY	DESCRIPTION	PART NUMBER
1	TOP	VARIES
1	SILICONE	100711

STEP 3:

- a. APPLY SILICONE ADHESIVE TO TOP EDGES OF APRON ASSEMBLY.
- b. APPLY SILICONE ADHESIVE IN DOT PATTERN LIKE SHOWN FOR BEST RESULTS.
- c. PLACE TOP ON UNIT WITH PROPER OVERHANG (CENTERED ON WORKSTATION).
- d. CLAMP ON TOP TO APRON ASSEMBLY TO REMOVE ANY WARP USING SHIMS AND C-CLAMPS, IF NEEDED, WHEN ALIGNING THE TOP (DO THIS BEFORE ADHESIVE ON EDGES SETS UP).
- e. LET CURE FOR 6-12 HOURS.

NOTE:

1.

TOP VIEW OF WORKSTATION SHOWN

REV.	DESCRIPTION	DATE	NAME	ECN NO.
C	UPDATED SILICONE PROCEDURE	8/18/23	RJM	-
A	CREATED DRAWING	11/16/16	EMR	-

REVISION LEVEL

ALL DIMENSIONS ARE IN INCHES UNLESS NOTED OTHERWISE DECIMALS: .X = ± .030 .XX = ± .020 .XXX = ± .010 ANGLES: = ± 1° CABINET SQUARENESS = ± .0625	DWN BY: EMR APR BY: APR BY:	DATE DWN: 11/16/16 DATE APR: DATE APR:
---	-----------------------------------	--

CONFIDENTIAL:  
ALL DESIGN RIGHTS RESERVED  
THE INFORMATION, DATA, DESIGN, AND DRAWINGS EMBODIED IN THIS DOCUMENT AND ALL REPRODUCTIONS THEREOF ARE THE EXCLUSIVE PROPERTY OF DIVERSIFIED WOODCRAFTS, INC.

THESE DOCUMENTS ARE SUPPLIED WITH THE UNDERSTANDING THAT THEY WILL NOT BE DISCLOSED TO THIRD PARTIES WITHOUT WRITTEN CONSENT OF DIVERSIFIED WOODCRAFTS, INC. ANY REPRODUCTION IN PART OR WHOLE WITHOUT WRITTEN CONSENT IS SUBJECT TO LEGAL ACTION.



300 South Krueger Street  
Suring, WI 54174  
diversifiedwoodcrafts.com

TITLE:  
OCTAGON WORKSTATION W/ PEDESTAL  
ASSEMBLY INSTRUCTIONS

DRAWING NUMBER:	SCALE:	SHEET:	REVISION:
OCTAGON WORKSTATION	NTS	5 OF 9	REV C

### HARDWARE REQUIRED FOR STEP

QTY	DESCRIPTION	PART NUMBER
1	FIXTURE - SINK	100697
1	SILICONE	100711

STEP 4:

- a. IF YOU DON'T HAVE A UNIT WITH A SINK OR FIXTURES, SKIP TO STEP 6.
- b. APPLY SILICONE ADHESIVE TO SINK OPENING ON TOP.
- c. LOWER SINK INTO OPENING.
- d. WIPE OFF ANY EXCESS CAULK AND ALLOW TO SET.
- e. LET CURE FOR 6-12 HOURS.

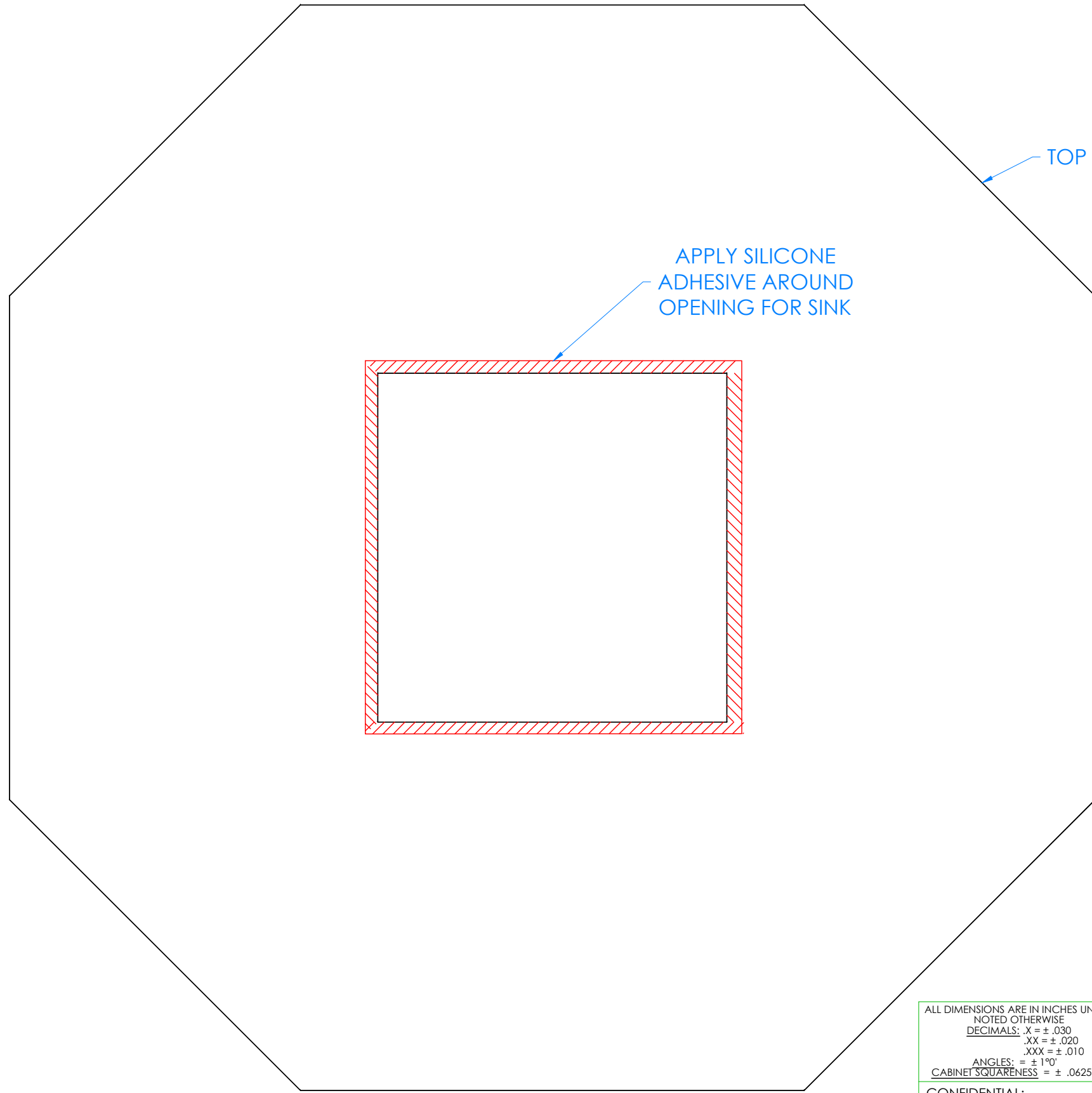

TOP VIEW OF WORKSTATION SHOWN

NOTE:

1.

ALL DIMENSIONS ARE IN INCHES UNLESS NOTED OTHERWISE	DWN BY: EMR	DATE DWN: 11/16/16
DECIMALS: .X = ± .030	APR BY:	DATE APR:
.XX = ± .020	APR BY:	DATE APR:
.XXX = ± .010	APR BY:	DATE APR:
ANGLES: = ± 1°		
CABINET SQUARENESS = ± .0625		



300 South Krueger Street  
Suring, WI 54174  
diversifiedwoodcrafts.com

CONFIDENTIAL:  
ALL DESIGN RIGHTS RESERVED  
THE INFORMATION, DATA, DESIGN, AND DRAWINGS EMBODIED IN THIS DOCUMENT AND ALL REPRODUCTIONS THEREOF ARE THE EXCLUSIVE PROPERTY OF DIVERSIFIED WOODCRAFTS, INC.

TITLE:  
**OCTAGON WORKSTATION W/ PEDESTAL ASSEMBLY INSTRUCTIONS**

THESE DOCUMENTS ARE SUPPLIED WITH THE UNDERSTANDING THAT THEY WILL NOT BE DISCLOSED TO THIRD PARTIES WITHOUT WRITTEN CONSENT OF DIVERSIFIED WOODCRAFTS, INC. ANY REPRODUCTION IN PART OR WHOLE WITHOUT WRITTEN CONSENT IS SUBJECT TO LEGAL ACTION.

DRAWING NUMBER:	SCALE:	SHEET:	REVISION:
<b>OCTAGON WORKSTATION</b>	NTS	6 OF 9	REV C

REV.	DESCRIPTION	DATE	NAME	ECN NO.
C	UPDATED SILICONE PROCEDURE	8/18/23	RJM	-
A	CREATED DRAWING	11/16/16	EMR	-

REVISION LEVEL

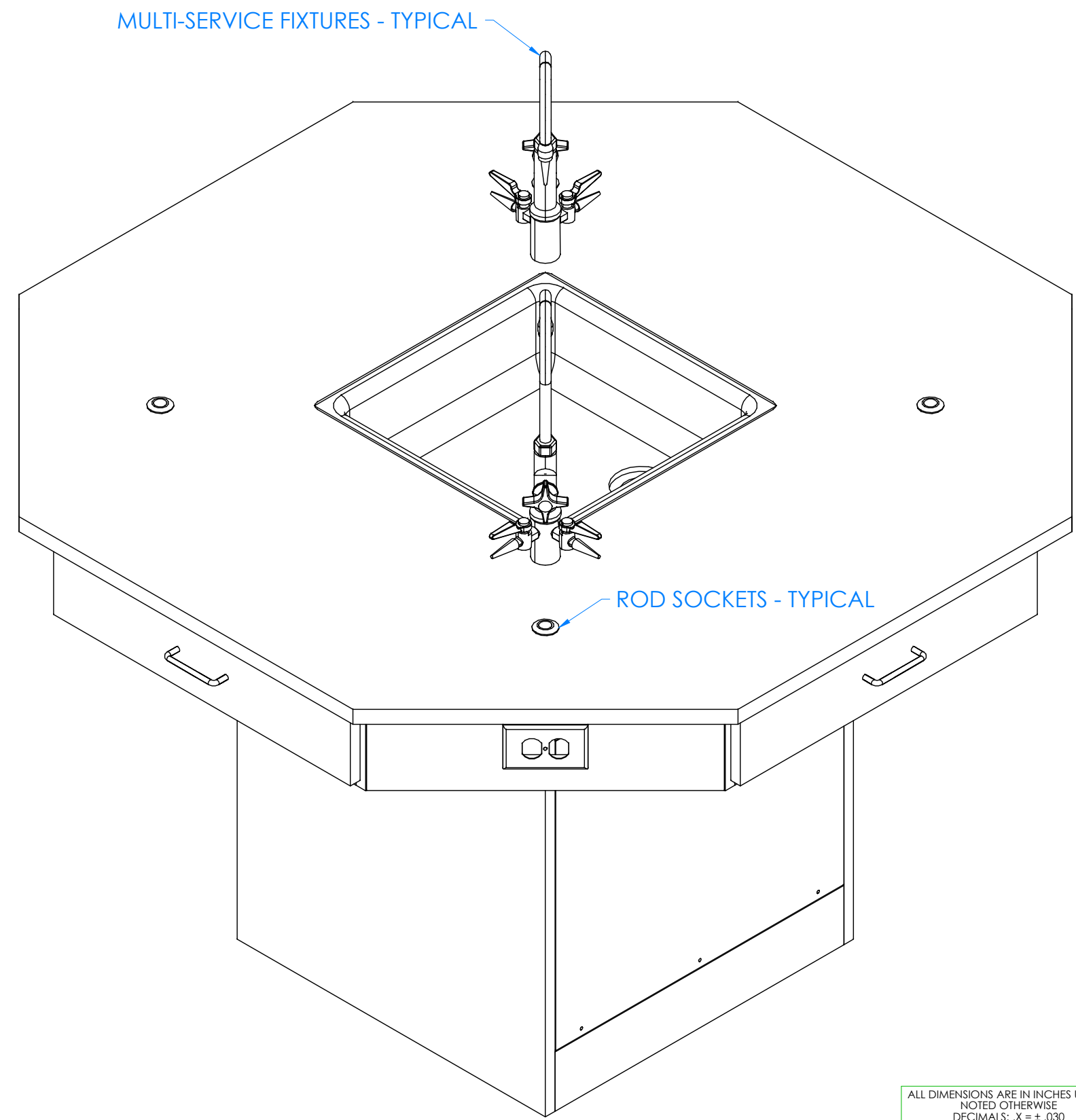

### HARDWARE REQUIRED FOR STEP

QTY	DESCRIPTION	PART NUMBER
2	FIXTURE - FAUCET	100074-BKR
1	FIXTURE - SINK TRAP	100056
1	FIXTURE - SINK OUTLET/STRAINER	254047
4	ROD SOCKETS	206505

STEP 5:

- a. INSTALL MULTI-SERVICE FIXTURES IN HOLES PROVIDED ON TOP.
- b. INSERT ROD SOCKETS INTO PRE-DRILLED HOLES IN TOP.

NOTE:

- 1. ALL WATER, ELECTRICAL, AND GAS CONNECTIONS SHOULD BE PERFORMED BY A TRAINED PROFESSIONAL PER LOCAL CODE.

REV.	DESCRIPTION	DATE	NAME	ECN NO.
C	UPDATED SILICONE PROCEDURE	8/18/23	RJM	-
A	CREATED DRAWING	11/16/16	EMR	-

REVISION LEVEL

ALL DIMENSIONS ARE IN INCHES UNLESS NOTED OTHERWISE  
 DECIMALS: .X = ± .030  
 .XX = ± .020  
 .XXX = ± .010  
 ANGLES: = ± 1°  
 CABINET SQUARENESS = ± .0625

DWN BY:	EMR	DATE DWN:	11/16/16
APR BY:		DATE APR:	
APR BY:		DATE APR:	

CONFIDENTIAL:  
 ALL DESIGN RIGHTS RESERVED.  
 THE INFORMATION, DATA, DESIGN, AND DRAWINGS EMBODIED IN THIS DOCUMENT AND ALL REPRODUCTIONS THEREOF ARE THE EXCLUSIVE PROPERTY OF DIVERSIFIED WOODCRAFTS, INC.

THESE DOCUMENTS ARE SUPPLIED WITH THE UNDERSTANDING THAT THEY WILL NOT BE DISCLOSED TO THIRD PARTIES WITHOUT WRITTEN CONSENT OF DIVERSIFIED WOODCRAFTS, INC. ANY REPRODUCTION IN PART OR WHOLE WITHOUT WRITTEN CONSENT IS SUBJECT TO LEGAL ACTION.



300 South Krueger Street  
 Suring, WI 54174  
 diversifiedwoodcrafts.com

TITLE:  
**OCTAGON WORKSTATION W/ PEDESTAL ASSEMBLY INSTRUCTIONS**

DRAWING NUMBER:	SCALE:	SHEET:	REVISION:
<b>OCTAGON WORKSTATION</b>	NTS	7 OF 9	REV C

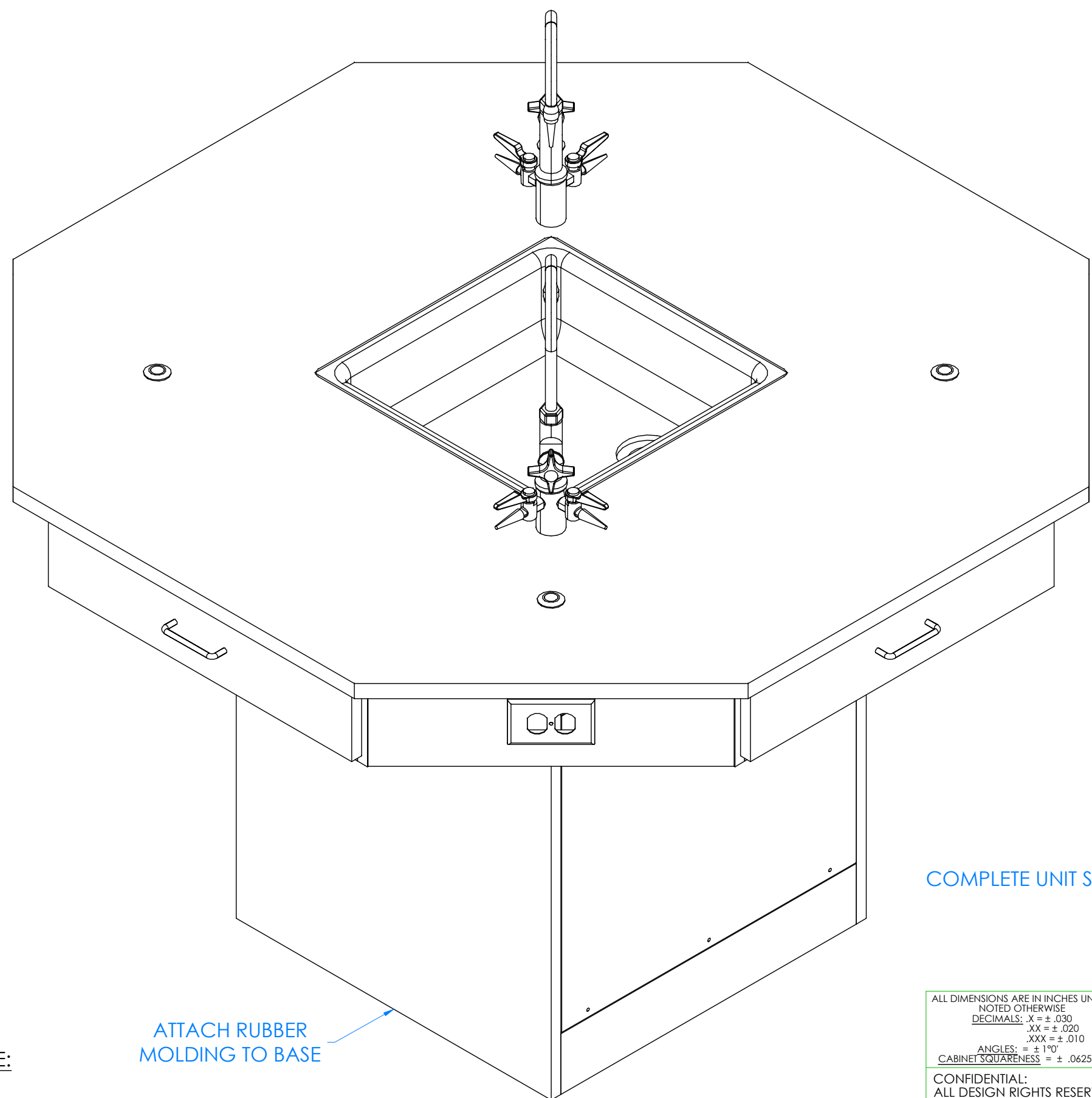

### HARDWARE REQUIRED FOR STEP

QTY	DESCRIPTION	PART NUMBER
VARIES	RUBBER BASE MOLDING	100283
4	STAINLESS STEEL CORNERS	100057
16	SCREWS - BASE	100064

STEP 6:

- a. ATTACH RUBBER MOLDING TO BASE OF WORKSTATION USING CONTACT CEMENT.
- b. SCREW STAINLESS STEEL CORNER BRACKETS ON EACH CORNER OVER BASE MOLDING USING PROVIDED HARDWARE LISTED ABOVE.

COMPLETE UNIT SHOWN

NOTE:

1.

ATTACH RUBBER MOLDING TO BASE

ALL DIMENSIONS ARE IN INCHES UNLESS NOTED OTHERWISE DECIMALS: .X = ± .030 .XX = ± .020 .XXX = ± .010 ANGLES: = ± 1° CABINET SQUARENESS = ± .0625	DWN BY: EMR APR BY: APR BY:	DATE DWN: 11/16/16 DATE APR: DATE APR:
---	-----------------------------------	--



300 South Krueger Street  
Suring, WI 54174  
diversifiedwoodcrafts.com

CONFIDENTIAL:  
ALL DESIGN RIGHTS RESERVED.  
THE INFORMATION, DATA, DESIGN, AND DRAWINGS EMBODIED IN THIS DOCUMENT AND ALL REPRODUCTIONS THEREOF ARE THE EXCLUSIVE PROPERTY OF DIVERSIFIED WOODCRAFTS, INC.

TITLE:  
OCTAGON WORKSTATION W/ PEDESTAL  
ASSEMBLY INSTRUCTIONS

THESE DOCUMENTS ARE SUPPLIED WITH THE UNDERSTANDING THAT THEY WILL NOT BE DISCLOSED TO THIRD PARTIES WITHOUT WRITTEN CONSENT OF DIVERSIFIED WOODCRAFTS, INC. ANY REPRODUCTION IN PART OR WHOLE WITHOUT WRITTEN CONSENT IS SUBJECT TO LEGAL ACTION.

DRAWING NUMBER:	SCALE:	SHEET:	REVISION:
OCTAGON WORKSTATION	NTS	8 OF 9	REV C

REV.	DESCRIPTION	DATE	NAME	ECN NO.
C	UPDATED SILICONE PROCEDURE	8/18/23	RJM	-
A	CREATED DRAWING	11/16/16	EMR	-
REVISION LEVEL				



## **TROUBLESHOOTING YOUR GFCI ELECTRICAL RECEPTACLE:**

**PLEASE NOTE: THROUGHOUT ANY OF THE FOLLOWING STEPS (PROCEDURES); IF YOU ARE NOT SURE YOU CAN DO THIS JOB SAFELY, AND COMPETENTLY, REFER THIS WORK TO QUALIFIED PROFESSIONAL!**

**If your unit comes equipped with a GFCI (Ground Fault Circuit Interrupter) electrical receptacle, and there is no power in the receptacle please consider/check the following:**

- The extension cord (if being used) is working properly.
- The breaker hasn't been tripped, or turned off.

This type of GFCI has two testing-related buttons on it. One button is appropriately labeled "TEST", and the other button is labeled "RESET". To test the GFCI receptacle follow these steps:

- Plug in an appliance (lamp or night light) into the outlet. The light should now be on. Then press the "TEST" button on the GFCI. The GFCI "RESET" button should pop out, and the light should go out.
- If the "RESET" button pops out, but the light doesn't go out, the GFCI has been improperly wired. In this case please contact a certified professional. There may also be a problem with other wiring in the same circuit.
- If the "RESET" button doesn't pop out, the GFCI is defective, or malfunctioned, and should be replaced.
- If the GFCI is functioning properly, and the lamp goes out, press the "RESET" button to restore power to the outlet.

Conversely, if you have a GFI that has tripped (which is common) and it will not reset, you may have a wiring short in the circuit, a defective appliance on the circuit, or the GFI itself has become defective. To test a tripping GFCI follow these steps:

- Remove every appliance connected to the GFCI's circuit and reset it. If it doesn't reset there may either be a wiring fault behind a socket outlet, or your GFCI itself has become faulty.
- Make sure whatever you are plugging into to the GFCI is dry and not damaged.
- Only plug in one item at a time. If you are plugging in a defective item it will cause the GFCI to trip, and that item therefore should be replaced.

If you are still having difficulty the easiest way to troubleshoot a GFI is to obtain a GFI tester, which is available at most hardware stores. It plugs into the GFI outlet, and will supply you with a "snapshot" of your connections, indicating wiring problems and/or the condition of the GFI. Another way to troubleshoot is to simply purchase a new GFI and install it.