

Trade Mark:
CRYSTAL WORLD INC

Product Name: Pendant lamp
Model :5535P20C
120Vac, 60Hz, AC ONLY
Lamp Size:Ø20"*H59"

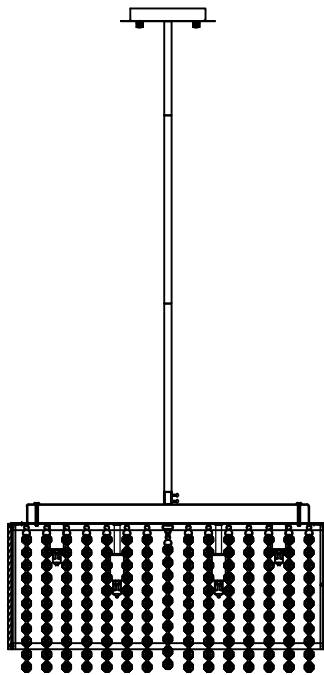

PENDANT LAMP ASSEMBLY INSTRUCTIONS



1. Place fixture(A) onto mounting screws (DD), secure with cap nuts (AA). Please fix (A) with (B), (B) with (C), (C) with (D).

Hardware Used

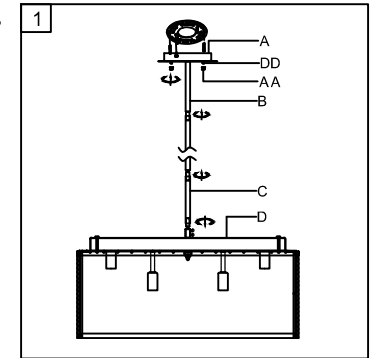
AA Cap nut  X 2
DD Mounting screw  X 2



2. Please hang the crystal (1) (2) to the fixture .

1  14mm*11PCS
158PCS
2  14mm*10PCS
1PCS

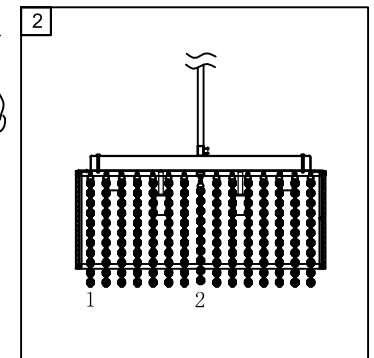

3. Install light bulbs (not included).
Use bulb  12*40W Max.

