

**NOTE: NEED TO ADD TECHNICAL INFORMATION**

**CONTRACT RIDER**

Current: January 1st, 2019

RIDER TO BE ATTACHED TO AND MADE PART OF CONTRACT DATED \_\_\_\_\_  
\_\_\_\_\_ Between **Grady Nichols** (Hereinafter referred to as "ARTIST") and  
\_\_\_\_\_ (Hereinafter referred to as "PURCHASER"). In the event of any inconsistency  
between this rider and the contract to which it is attached, the terms of the rider shall prevail.

**1. GENERAL PROVISIONS:**

The following rider represents the requirements of the ARTIST on the attached contract. PLEASE READ IT CAREFULLY. By signing it, you are agreeing to supply the ARTIST with certain equipment and working conditions, which are essential to their performance. Any breach of the terms of this rider is a breach of the contract and may cause the ARTIST to refuse to perform, without releasing you from the obligation to pay them.

We look forward to a smooth and successful engagement and would be happy to assist you in any way. If there are any problems in fulfilling any of these requirements, please call as soon as possible. DO NOT MAKE ANY CHANGES WITHOUT PERMISSION FROM MANAGEMENT. Thank you for your cooperation.

**Contact:**

**Grady Nichols  
Grady Nichols, Ltd.  
5103 S. Sheridan #534  
Tulsa, OK 74145  
Cell: 918-74-6074  
mgmt@gradynichols.com**

**1. Deposit / Payment**

Unless prior arrangements have been made:

- A. The agreed upon deposit must be mailed as soon as possible to: Grady Nichols, Ltd., 5103 S. Sheridan #534, Tulsa, OK 74145.
- B. All monies due the night of the performance shall be paid in U.S. cash dollars.
- C. All monies shall be paid directly to Artist or Artist's designated representative prior to the final performance.

**2. Billing / Other Artists**

The correct billing for Artist, applicable in all promotional materials shall be:

**Grady Nichols**

The Artist will be given 100% top/star billing (see above) in any and all paid advertisements and publicity, including, but not limited to posters, fliers, programs, signs, marquees and banners. Purchaser will notify Artist of any other artist(s) that may appear at the same engagement. The Artist reserves the right to appear before or after any other artist (s)' performance and has the right to determine the length of any other artist(s)' performance.

Initials \_\_\_\_\_

Instrumentation is as follows (**subject to change**):

<u>Musician</u>	<u>Instrumentation</u>
Grady Nichols	Saxophone
Mike Wilson	Keyboards/Vocals
Chuck Tottress	Bass
Jo Nathan Watkins	Drums
David John	Guitar

**3. Transportation / Hotel**

In addition to the agreed transportation/hotel accommodations in the contract, **PURCHASER** shall provide (at no expense to **ARTIST**) all local transportation needs. This includes airport/hotel/sound check/performance/ hotel and return to airport and any promotional events, such as radio, TV, etc. by van (15 passenger capacity, with last two rows of seats removable) or suitable vehicle to accommodate acoustic bass in a flight case. Transportation between venue over fifty (50) miles may be provided by motor coach (with sleeping berths), rail, airplane or limousine subject to approval.

All hotel accommodations will be in a minimum four star hotel near the place of the performance, and will consist six (5) single rooms (for the band and crew) nightly for the entire engagement, with a telephone and television in each room and a fax machine and a restaurant in the hotel. If hotel accommodations are not included in the contract, Purchaser will make the necessary arrangements for the above, taking full advantage of Purchaser's performer/corporate rates on behalf of Artist.

Hotel information should be faxed to management as soon as possible.

**4. Setup / Rehearsal**

On the first day of the performance, the venue will be made available to Artist for technical setup and rehearsal **at least** three hours prior to the first performance. Purchaser will provide the house electrician, house sound technician, house spotlight operator and a minimum of one stagehand/loader/unloader at that time. One loader/unloader will also be made available to Artist during load-out following the performance. The audience will not be permitted into the room of the performance until setup/rehearsal is completed. Purchaser will provide all equipment per the attached plot. No instruments other than those provided by/for Artist will be allowed on the stage.

**5. Dressing Rooms / Security**

Purchaser will provide at least one dressing room adequate for use by six (6) people during Artist's entire performance. Room(s) shall be clean, dry, well lit, heated or air-conditioned and shall have a mirror and comfortable seating for six persons. Dressing room(s) shall have easy access to clean bathrooms, be locked or suitably secured.

Initials\_\_\_\_\_

## **CONTRACT RIDER**

Current: January 1st, 2019

Purchaser will also provide **(NO FAST FOOD)** hot meals for five (5) on each night of the engagement.

Purchaser will guarantee proper security to all musicians, instruments and their personal property before, during and after the performance(s). Special attention is to be paid to the dressing room(s), stage areas and all entrances and exits. Proper security will commence upon Artist's arrival.

### **6. Ancillary Sales**

Purchaser agrees to supply Artist with adequate space (and if necessary a sales person) for the Artist or his representative to sell recordings, photos, apparel, souvenir books, etc. at the place of performance. The Artist retains the sole and exclusive right to sell such material and no other such sales will be permitted at the place of performance without the expressed written permission of Artist.

### **7. Use of Artist Name / Interviews**

The name of Artist may not be used or associated, either directly or indirectly, with any product or service without Artist's prior written permission. Pre-tour interviews will be granted to individuals representing major print or electronic media wherever possible. All requests for interviews should be submitted to management. Requests must include the following information:

- Name of person who will perform the interview
- Name of publication or radio/TV station
- Phone number/address of interviewer/publication
- Type of interview (phone/live)
- Length of interview

Artist availability for interview cannot be guaranteed. Artist retains the right to approve or disapprove of any interviews for print or electronic media in conjunction with the performance.

Day of performance interviews and/or autograph sessions will take place only if time permits. Purchaser agrees that it will not commit Artist to any personal appearances, interviews or any other type of promotional appearance without Artist or Artist's representative giving prior consent. Such arrangements shall be made through Artist's representative.

### **8. Complimentary Tickets**

Upon request, Purchaser will provide Artist with a reasonable number of complimentary tickets.

### **9. Recording / Photography**

There will be no audio recording, video recording or radio broadcasts during the performance unless prior written permission is granted by Artist or Artist's representative. All cassette recorders, video recorders, DAT machine or other unauthorized taping equipment shall be confiscated by Purchaser and held until completion of the performance. Artist has right to tape performance.

Flash photography of Artist during the performance is permitted only on the first three songs of the concert. Non-flash photography will only be permitted with consent from Artist or Artist's representative. If such permission is granted, the photographer must provide Artist's representative with contact sheets and agree to provide Artist with one photograph of Artist's choice gratis, to be used for publicity purposes.

Initials\_\_\_\_\_

**CONTRACT RIDER**

Current: January 1st, 2019

**10. Miscellaneous**

Artist has 100% control of the performance.

Artist's obligations hereunder are subject to detention or prevention by sickness, inability to perform, accident, transportation delays, acts of God, labor difficulties, epidemics, or any act or order of a public authority or any other cause, similar or dissimilar, beyond Artist's control.

In the event of a breach by Purchaser of any of the terms, covenants or conditions of this contract, Artist shall not be required to perform hereunder and Purchaser shall pay to Artist the full amount of fixed payments required hereunder. A breach of any clause contained in this rider by Purchaser shall be deemed a material breach. If Artist elects to perform notwithstanding a breach of this agreement by Purchaser, the performance by Artist shall not constitute a waiver of any claim Artist may have for damages or otherwise.

Purchaser shall provide Artist's representative with original copies of all press releases, fliers, posters, articles and reviews pertaining to said performance.

In case of any conflict of terms, the terms contained in this rider shall prevail over any others. All terms of this rider are specifically accepted by Purchaser unless they are waived by Artist or Artist's representative. Such waiver shall only be effective if initialed by both Artist or his representative and Purchaser.

**11. Sound / Musical Equipment Supplied by Purchaser**

The attached Schedule "A" is made fully a part of this agreement.

**12. THE ATTACHED STAGE PLOT IS MADE FULLY A PART OF THIS AGREEMENT.**

**AGREED AND ACCEPTED BY:**

\_\_\_\_\_  
PURCHASER

\_\_\_\_\_  
GRADY NICHOLS, LTD.

\_\_\_\_\_  
DATE

\_\_\_\_\_  
DATE

## GRADY NICHOLS PERFORMANCE AGREEMENT SCHEDULE "A"

Current: January 1st, 2019

### **SOUND / MUSICAL EQUIPMENT SUPPLIED BY PURCHASER**

Stage size: 28' deep x 40' wide  
Five music stands with concert lights

#### Saxophone

- ◆ Grady provides his own SM 98 instrument microphone but requires the LX1 system Body pack transmitter and the wireless LX receiver.
- ◆ Lexicon MPX 550 24-bit Dual Channel Processor  
(The TC Electronics M-One is still a viable option if the Lexicon is not available)
- ◆ Vocal mic on stand at center stage for talking between songs

#### Keyboards

- ◆ Korg Triton keyboard
- ◆ Korg Triton Extreme 61 key keyboard
- ◆ Sustain pedals, stacking keyboard stand, keyboard stool, connections cables
- ◆ Quality Vocal mic with boom stand

#### Bass

- ◆ Gallien-Krueger Head either: 800rb, 250rb, or 350bl model
- ◆ One Gallien-Krueger 410sbx speaker cabinet
- ◆ One Gallien-Krueger 115bl cabinets

#### Drums

- ◆ One 4-piece drum kit. Order of preference:
  1. DW
  2. Yamaha
  3. Pearl
- ◆ Cymbals: 2 crash, 1 ride, 1 pair Hi-hats

#### Guitar

- ◆ 2X12 combo amp. Order of preference:
  1. Top Hat Club or King Royale 2x12
  2. A Matchless or Bad Cat 2x12
  3. A newer VOX AC-30 2x12
  4. Last resort: Fender Twin 2x12
- ◆ Taylor or Breedlove Acoustic Guitar with LR Baggs or iBeam pickup system

#### Vocalist

- ◆ Quality vocal mic with boom stand

Initials\_\_\_\_\_

**Input List**

- 1) Bass Drum
- 2) Snare
- 3) Hi-Hat
- 4) Floor Tom
- 5) Rack Tom #1
- 6) Rack Tom #2
- 7) Overhead #1
- 8) Overhead #2
- 9) Electric Guitar Amp
- 10) Acoustic Guitar (DI)
- 11) Bass Amp (DI)
- 12) Keyboard #1 (DI)
- 13) Keyboard #2 (DI)
- 14) Vocal mic for keyboardist (background vocals)
- 15) Saxophone mic (wireless)
- 16) Saxophonist Vocal mic (announcements and background vocals)
- 17) Lead vocalist mic
- 18) Input for tracks from iPad (DI)

Initials\_\_\_\_\_



## Stage Requirements

Contact Name: \_\_\_\_\_

Phone: Day \_\_\_\_\_ Evening \_\_\_\_\_

Musical instruments are to be provided by the performers.  
Venue will provide sound and lighting.

Specific stage setup requirements:

# of Vocal Microphones- **3**

# of Instrument Microphones- **5 including 4 Drum Mics**

# of Direct Boxes- **5**

# of People in Group- **6**

# of Chairs- **1**

Other: **Risers- Drums Tier, 18" high, 8' wide**

### BACK STAGE

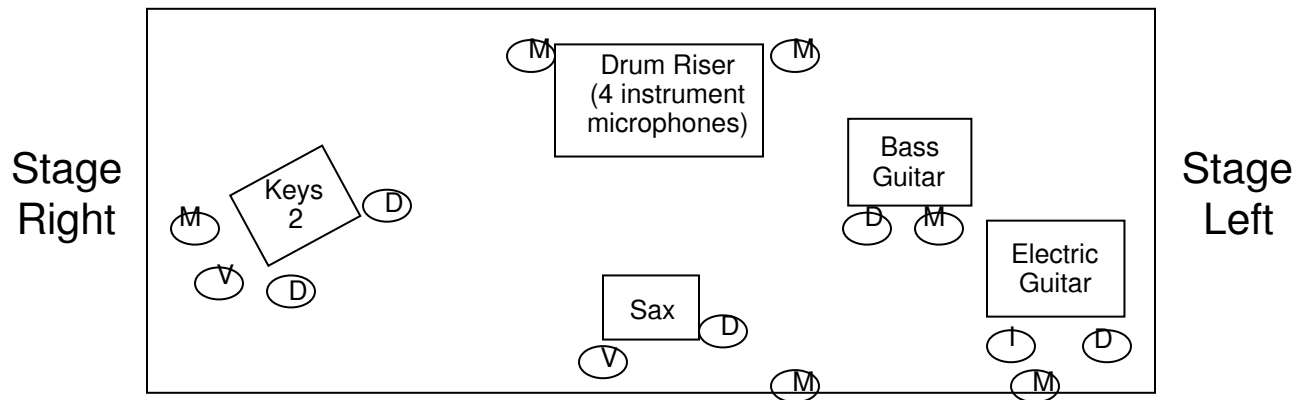

40 X 28

### AUDIENCE

Key: V – Vocal Microphone  
I – Instrument Microphone  
D - Direct Box  
M - Monitor

Initials \_\_\_\_\_