

ONTARIO
NORTHLAND
RAILWAY
DIARY
PAINTING
GUIDE

ONTARIO NORTHLAND RY

April 1948 said goodbye to a pioneer railway name, the Temiskaming and Northern Ontario Railway took on a name more indicative of its operating area and ownership by the Government of Ontario, it became the Ontario Northland Railway. With this name change came a broadening of services offered, from rail services and hotel services it spread to marina, highway, air and telecommunication services; a fully integrated transportation system.

It is only fitting that the first diesel, an Alco S-2 should arrive within two months of the name change. These units were painted in an eye catching colour scheme with orange side panels the main feature.

1949 saw the arrival of RS-2 locomotives painted with yellow pin stripes and a white letterboard stripe, the yellow used on these locomotives survived through several paint scheme changes. A review of colour photos by the author has verified the paint schemes of both these original locomotives and found four or more Alco road switchers received this first work.

The second paint scheme retained the dark green body colour and added a broad yellow stripe with the red roadname.

During 1965 two things were happening, firstly a new lighter green carbody colour was introduced on a limited number of locomotives and secondly the railway was studying a new image and logo. Both the lighter green scheme and the now familiar graphic design of an "O" superimposed over an "N" failed to become permanent and all locomotives were returned to the dark green and yellow by the early 1970's.

1973 was the year of the Northland Chevron, though it was not seen on locomotives until the second order for SD40-2's was delivered in January 1974. All subsequent locomotive deliveries, and it is assumed backshopped GEEP's and RS units will also be repainted in the Northland yellow, Northland blue, Ontario blue and Polar Bear white.

A review of the following drawings, B/W and colour photos will show this paint scheme to be one of the most striking to have been developed in the 1970's.

Continuing the progressive image cast by their new colour scheme the Ontario Northland management and the Ontario government brought a new dimension to railway passenger transportation by bringing to Canada four Trans-Europe express train sets that began operation as the (new) "Northlander" in May 1977 between Toronto and Kapuskasing over both ONR and CNR tracks.

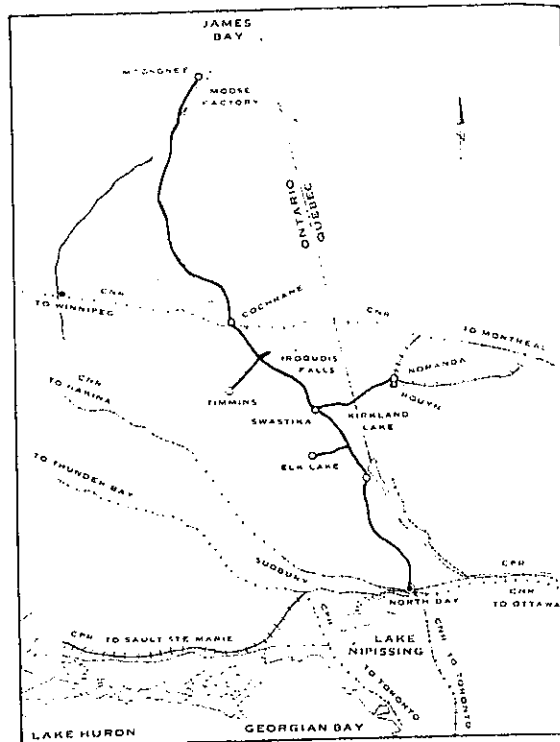

PIERRE PATENAUDE



1517 With 1505 at Cochrane, Ontario, August 18, 1972 show the main features of the next to latest paint scheme. Red outlined & yellow on white provincial crest at top of nose door, and FP7-A in 5" yellow letters would be the most overlooked items.

LPD

RAIL CANADA vol. II

PAINTING AND LETTERING GUIDE
FOR CANADIAN RAILWAYS

Subject - DIESEL LOCOMOTIVES
Section - PROTOTYPE PHOTOS
Railway - ONTARIO NORTHLAND

Date 4-29-77

By: D.C.L.

Drg. No. PP-18

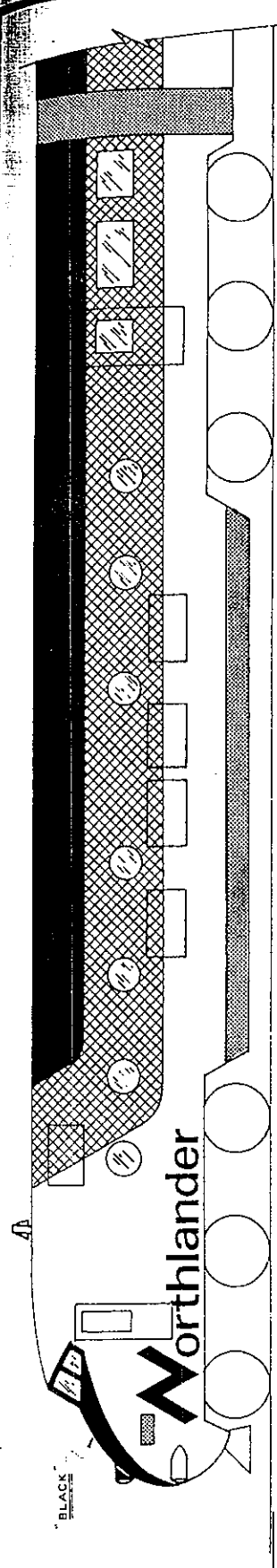

YELLOW ○ DK. BLUE ● LT. BLUE ▨ BLACK ▩

ONTARIO NORTHLAND

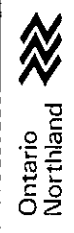

The publishers and author of Rail Canada are proud to have been able to present a colour photo of the Northlander being tested at Cobalt, Ontario on the cover of this volume.

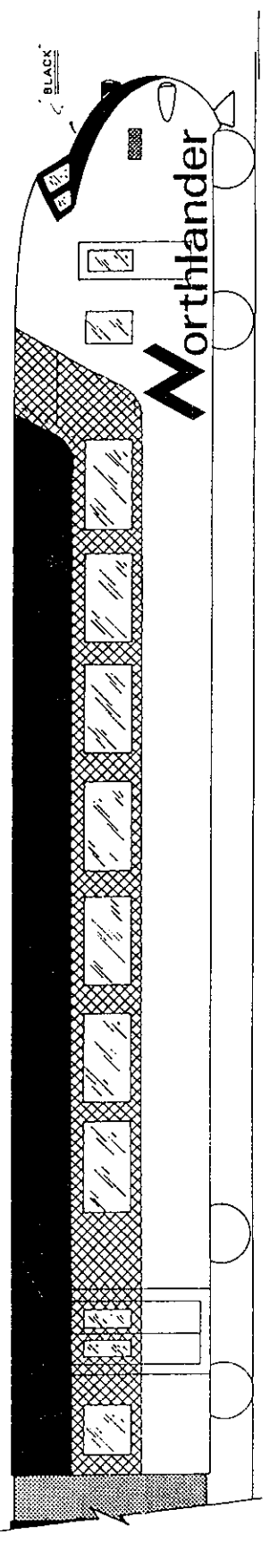
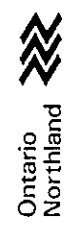
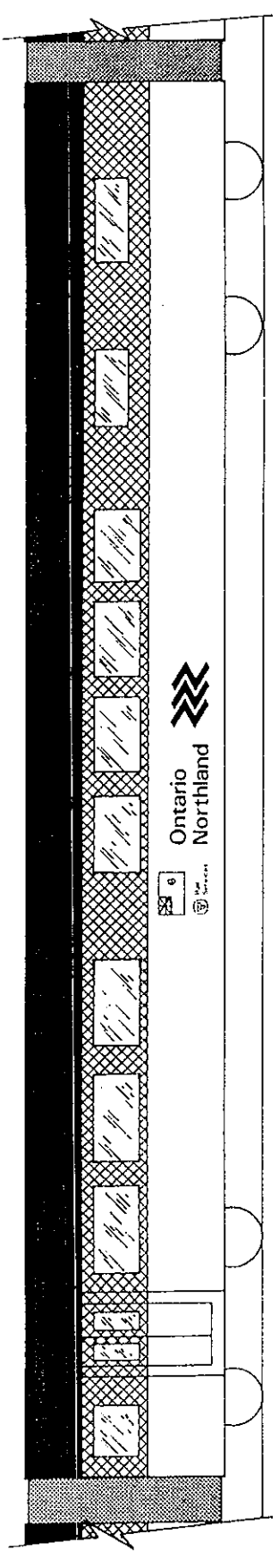

Northlander

PD

RAIL CANADA vol. II

PAINTING AND LETTERING GUIDE FOR CANADIAN RAILWAYS

Subject - DIESEL LOCOMOTIVES
 Section - OUTLINE DRAWINGS
 Railway - ONTARIO NORTHLAND

Revision

Date: 4-5-77 By: D.C.L. Drg. No.: D 32

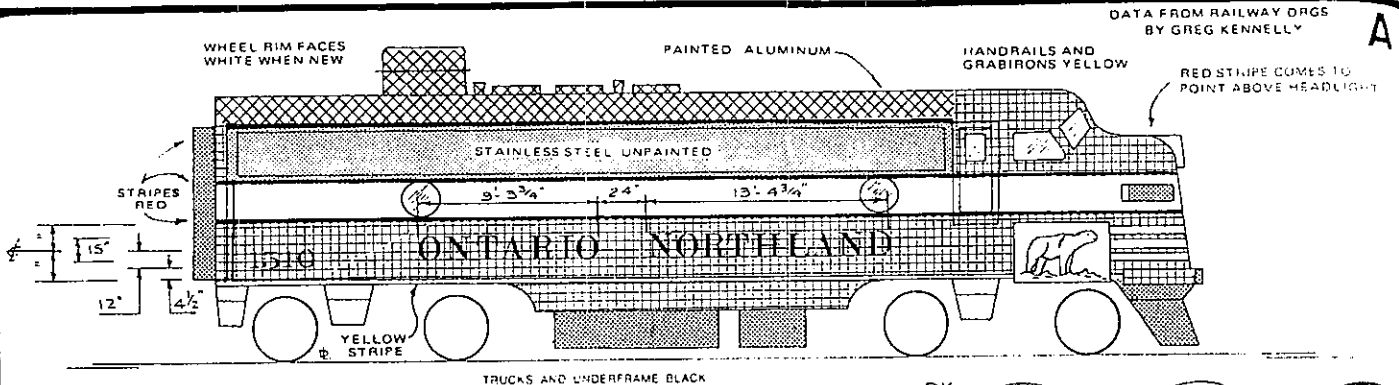

O.N.R., 1500 CLASS
GMDL., FP7A, 1750 hp., B-B

Northlander sign blue with white Polar Bear, Bear faces engine front on both sides.
Provincial Coat of Arms shown in post Oct. 15, 1953 position when it was moved to top of front door.
While an experimental point scheme was applied to three FP 7A's for a period of time in the mid 60s, this scheme lasted until the 1973 NORTHLAND blue and yellow came into use.

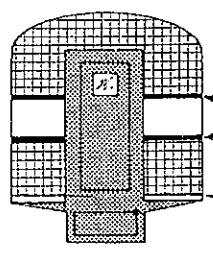

REAR

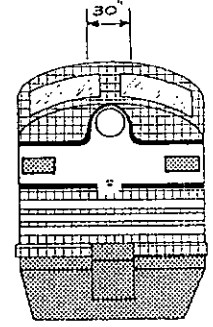

FRONT

DIMENSIONAL DATA FROM RAILWAY DRGS. BY GREG KENNELLY

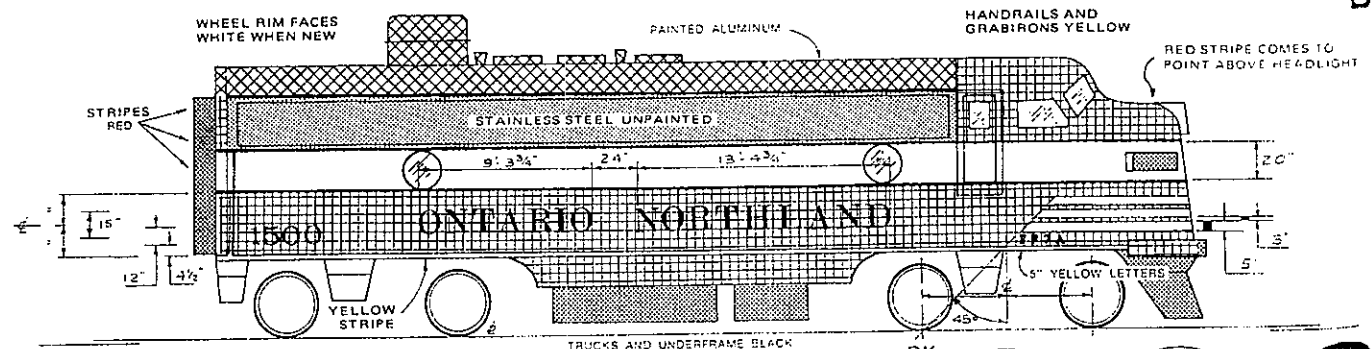

O.N.R., 1500 CLASS
GMDL., FP7A, 1750 hp., B-B

15" yellow road name and 12" road numbers highlight the green side panel while the three yellow stripes set off the nose. Front door green with black Coat of Arms on white shield.
Lower yellow nose stripe at bottom of front door.
5" yellow FP7A stencil on each side at rear of bottom nose stripe.
Red and yellow side stripes width of lap plates. Note red stripe on roof, ends short of rear edge.

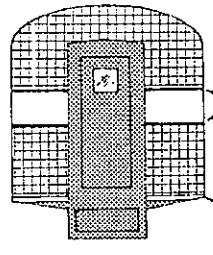

REAR

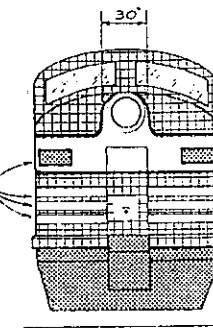

FRONT

LPD

RAIL CANADA vol. II

PAINTING AND LETTERING GUIDE FOR CANADIAN RAILWAYS

Subject - DIESEL LOCOMOTIVES
Section - OUTLINE DRAWINGS
Railway - ONTARIO NORTHLAND

Date: 1-12-77 By: D.C.L. Drg. No. D-33

O.N.R.
GMDL.

Exp.
Light
Main
Top
O.T.

O.N.R.
GMDL.

Rail
Main
Top
Exp.
Prev

LPD

A 3-24
Rev.

A 3-10 77
Revision

A

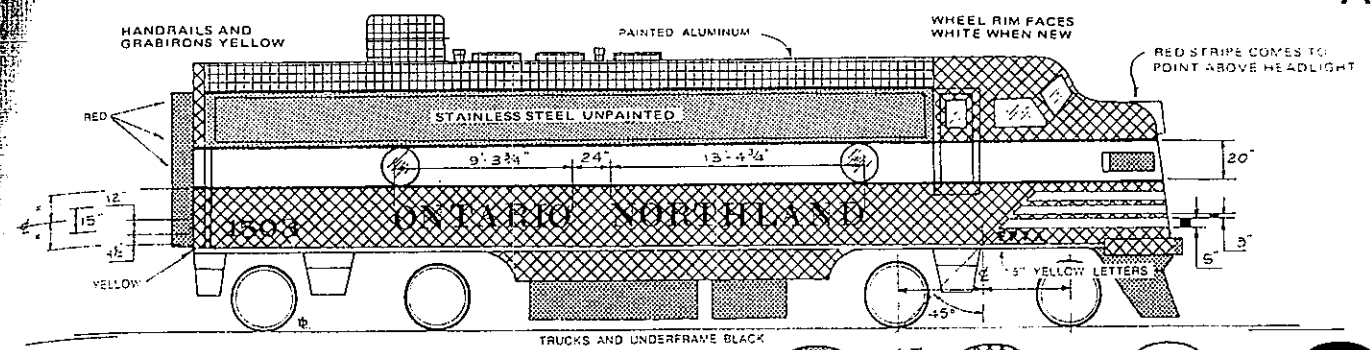

O.N.R., 1500 CLASS
GMDL., FP7A, 1750 hp., B-B



Experimental scheme tried for a time by O.N.R. during 1965--66
Light green cab and side panel area should have made the units easier to see in Ontario's green forests but did not find acceptance and the FP7A and RS10 were repainted to the dark green.
The Atlas FP7A will make an excellent basis for a model of these O.N.R. units

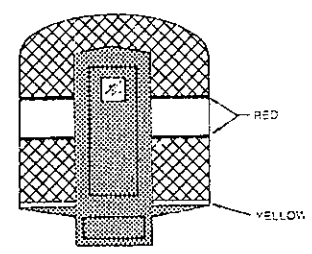

REAR

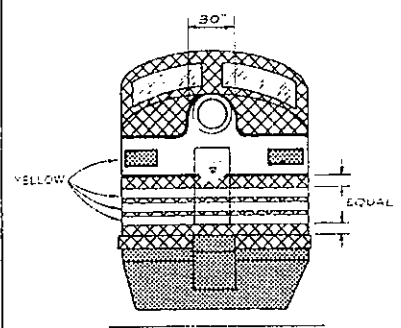

FRONT

B

DATA BASED ON PHOTOS AND RAILWAY DATA

B

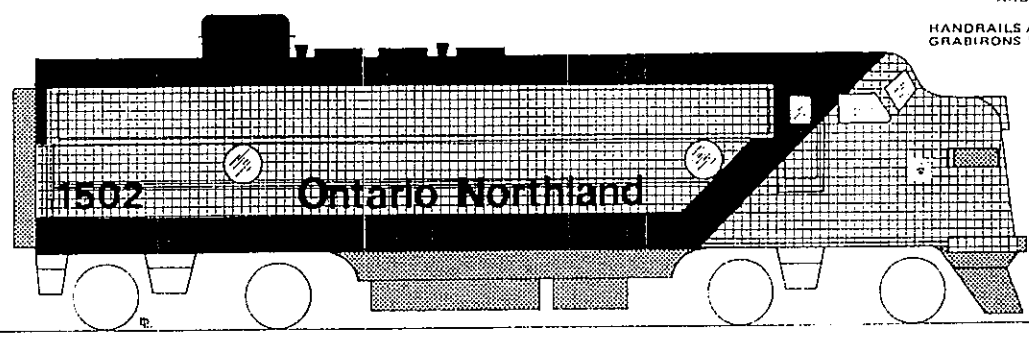

O.N.R., 1500 CLASS
GMDL., FP7A, 1750 hp., B-B



Reflecting the O.N.R. forward looking approach to operating a modern integrated transportation company, this new paint scheme was developed in 1965 and applied to five or six locomotives during the late 1960's. All units were returned to the green and yellow scheme.
The contemporary industrial design chosen for the company symbol may still be seen on box cars travelling around North America.
The road name and numerals are presented in the "new haus bo d" typeface.
Provincial Coat of Arms on cab side behind the number boards.

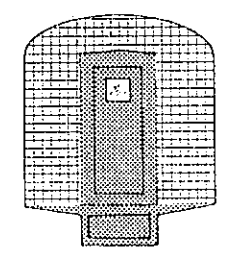

REAR

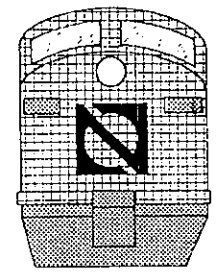

FRONT

LPD
A 3-24-77
Revision

RAIL CANADA vol. II

PAINTING AND LETTERING GUIDE FOR CANADIAN RAILWAYS

Subject - DIESEL LOCOMOTIVES
Section - OUTLINE DRAWINGS
Railway - ONTARIO NORTHLAND

Date 2/29/70 By D.C.L. Dwg. No. D 34



PIERRÉ PATENAUDE

1502 While not the best of photos this picture of the polar bear express at Moosonee, Ontario, August 17, 1972. Does show the white polar bear on the blue board attached to the locomotive side. Note bears are opposite hand on locomotive.

Passenger cars have provincial crest on sides at each end. "Polar Bear Express" on coach side is flanked by polar bears facing each other.

1301 Location and date of this photo is unknown but it does show some unusual features. Note the caboose style brake stand on rear side platform and chain linkage connecting rear truck brake cylinders. Also note both side and end number boards. Note Ontario Northland lettering on tender at right.

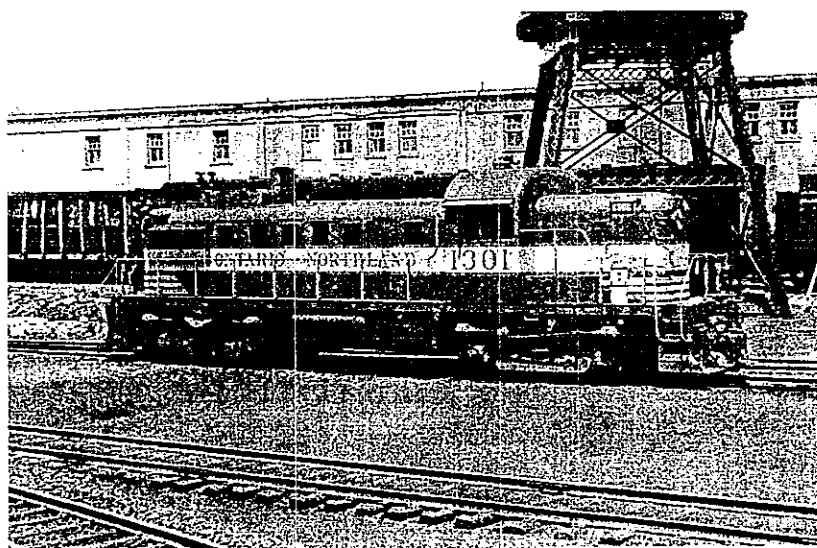

KEN WILSON COLLECTION

O.N.R. 15
GMD., FP

The 15
used by

The 15
of Ont
in the

Style
with

North
number

All ca
hastra

The 15
1950's

O.N.R. 1
MLW., R

The fir
modified
these un

The part
in bed
yellow

AHM B
sonable
and RS
plastic
Units ca
imports

LPD

RAIL CANADA vol. II

PAINTING AND LETTERING GUIDE FOR CANADIAN RAILWAYS

Subject - DIESEL LOCOMOTIVES

Section - PROTOTYPE PHOTOS

Railway - ONTARIO NORTHLAND

Date. 4-23-77

By: D.C.L.

Drg. No. PPT/100

LPD

Revision

HANDRAILS AND GRABIRONS LT. BLUE

TOP SURFACE OF SUNSHADE LT. BLUE

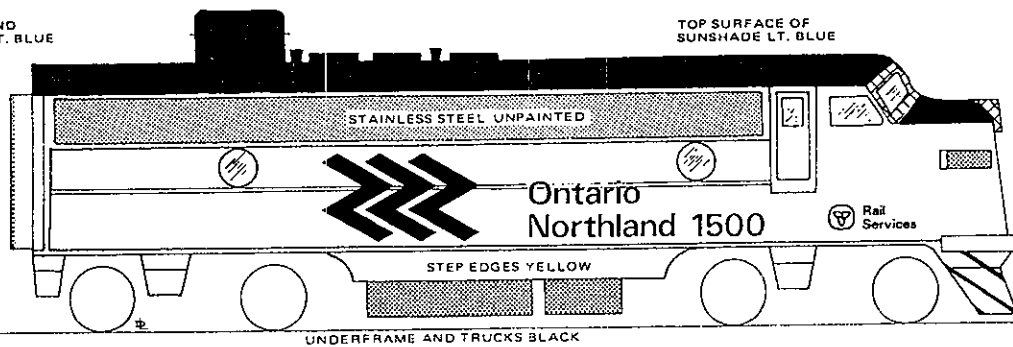

UNDERFRAME AND TRUCKS BLACK

O.N.R. 1500 CLASS

GMD., FP7A, 1750 hp, BB

The 1970's look in paint schemes may well be the most striking used by any railway in Canada.

The Northland yellow and Northland blue with the accent colors of Ontario blue (light) and Polar Bear white certainly stand out in the forest or tundra of northern Ontario.

Style of lettering applied is univers bold and one that complies with size requirements specified by AAR.

Northland Chevrons are applied on the nose of the a units below the number boards which have black with white numerals.

All carbody lettering, northland (dark) blue with grabirons and handrails Ontario (lt.) blue.

The yellow used is the same used for striping on engines since the 1950's.

LT. BLUE DK. BLUE YELLOW BLACK

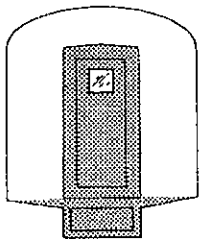

REAR

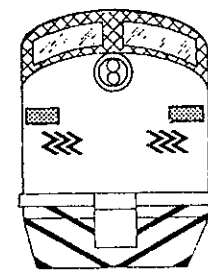

FRONT

YELLOW HANDRAILS AND POSTS ABOVE DECK PLATE

YELLOW NUMERALS

ROADNAME RED

DATA BASED ON PHOTOS
ALL NUMBER LAMPS
4 1/2" WHITE NUMBER WITH
RED BACKGROUND

5" YELLOW F
BOTH SIDES FRONT

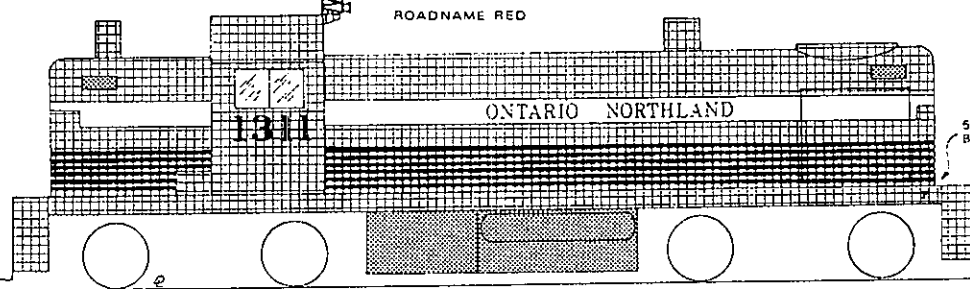

UNDERFRAME AND TRUCKS BLACK

GREEN WHITE YELLOW BLACK

O.N.R. 1300 CLASS

MLW., RS-3, 1600 hp., B-B

The first road switchers on the O.N.R. were two Alco RS 2's, later modified to resemble an RS-3 in most respects, including rating, these units received a distinctive paint scheme.

The paint shop foreman and his staff must have wished they stayed in bed when they saw the amount of masking required for the yellow stripes.

AHM:Riverassi make a plastic model of an RS 2 that makes a reasonable beginning to modelling the O.N.R. RS-2 and RS 3 locomotives. Many years ago Hobbytown offered both a plastic and a cast metal version of Alco 1600. These units can still be found around North America as can 2 or 3 brass imports by International and more recently by Alco Models.

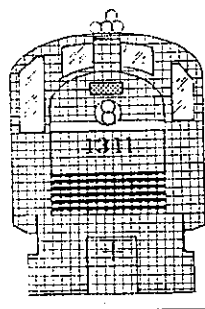

REAR

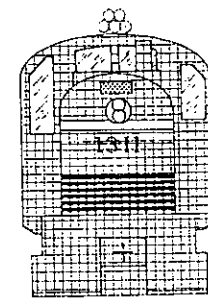

FRONT

LPD

RAIL CANADA vol. II

PAINTING AND LETTERING GUIDE FOR CANADIAN RAILWAYS

Subject - DIESEL LOCOMOTIVES
Section - OUTLINE DRAWINGS
Railway - ONTARIO NORTHLAND

Date 1-10-77 By D.C.L. Drg. No. D-35

Revision

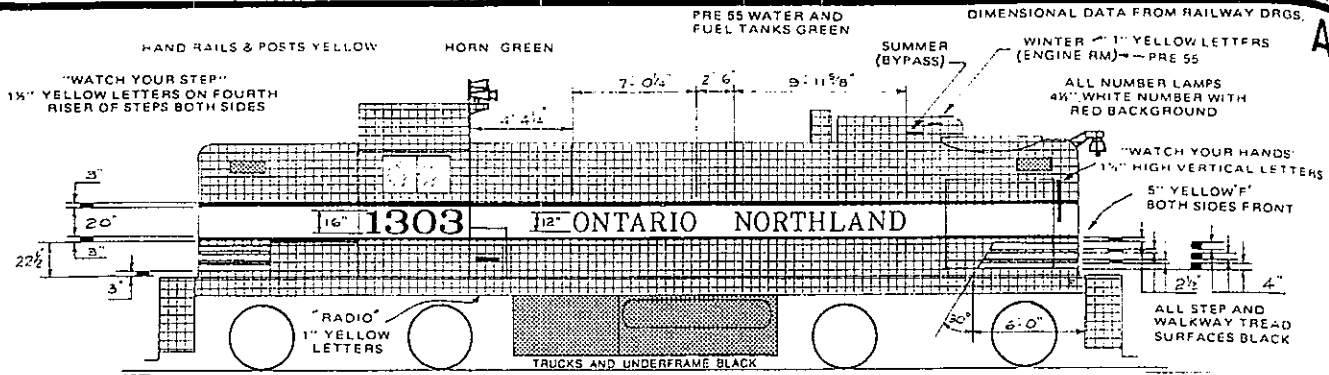

O.N.R. 1300 CLASS

MLW., RS-3 (RS-2), 1600 hp., B-B

The drawing above should be quite explanatory for this paint scheme, as was the railway drawing we worked from.

One note is required though. Where notes or stencil data crosses over from one color to another the contrasting color is used on the stencil.

The most unusual feature of this scheme was painting the wheel rim faces white, while white tire faces were common to steam engines they were seldom seen on diesels. A touch of class perhaps!

WHEEL RIM FACES
WHITE WHEN NEW

CARBODY FILTERS
UNPAINTED

BLACK

GREEN

YELLOW

RED

END HAND BRAKE
WHEEL PAINTED GREEN

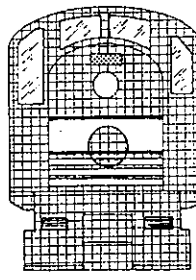

REAR

DO NOT GET
ON FOOTBOARD
WHEN ENGINE
IS APPROACHING

1" YELLOW LETTERS
BOTH ENDS

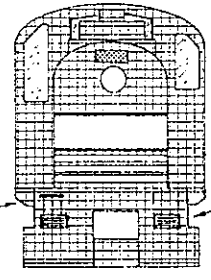

FRONT

"SNOW PLOW HORN"
7/8" YELLOW

DATA BASED ON PHOTOS

STEP HANDRAILS
WHITE, BOTH SIDES
FRONT AND BACK

CARBODY FILTERS
UNPAINTED

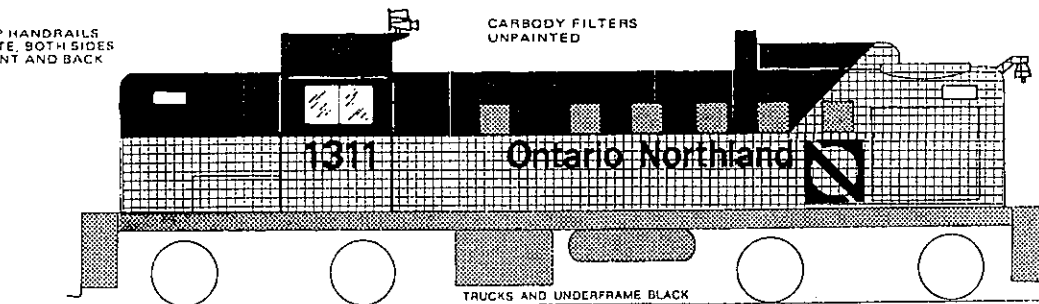

O.N.R. 1300 CLASS

MLW., RS-3, 1600 hp., B-B

One RS-3 received the "Progressive" paint scheme shown here. The handrails and posts are green except for the step handrails which are white to the first post.

GREEN

WHITE

BLACK

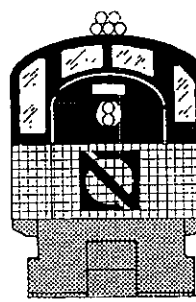

REAR

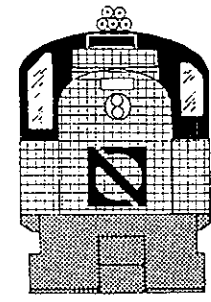

FRONT

"WATCH YOUR STEP"
1 1/2" YELLOW LETTERS
RISER OF STEPS BOTH SIDES



WALKWAYS

O.N.R., 14
MLW., RS-

The self rather int
Models RS 10:1
by L.C.L.

"WATCH YOUR STEP"
1 1/2" YELLOW LETTERS
RISER OF STEPS BOTH SIDES



WALKWAYS

O.N.R., 14
MLW., RS-

Experiment green, all above

WATCH YOUR STEP
YELLOW LETTERS ON FOURTH RISER OF STEPS BOTH SIDES

WALKWAYS BLACK

WHEEL RIM FACES WHITE WHEN NEW

UNDERFRAME AND TRUCKS BLACK

END HAND BRAKE WHEEL PAINTED GREEN

5" YELLOW 'F' BOTH SIDES FRONT

STEP RISERS AND TREADS GREEN

1" YELLOW LETTERS BOTH ENDS

DO NOT GET ON FOOTBOARD WHEN ENGINE IS APPROACHING

GRABIRONS YELLOW

BLACK

DK GREEN

YELLOW

RED

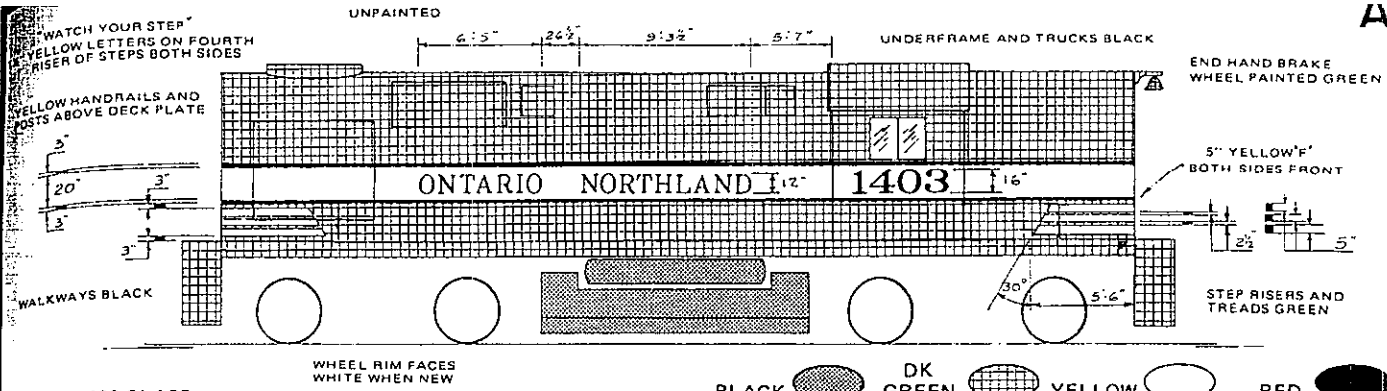

O.N.R., 1400 CLASS
MLW., RS-10, 1600 hp., B-B

The self explanatory drawing above makes notes on the paint work rather unnecessary.

Modelers who do not have an Alco models C.P.R. RS-18 (some say RS-10) to start from will end up reworking a plastic RS-11 import by Life Like or Model Power.

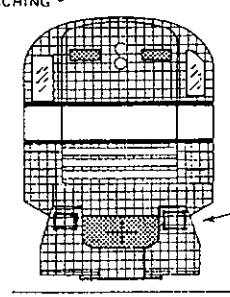
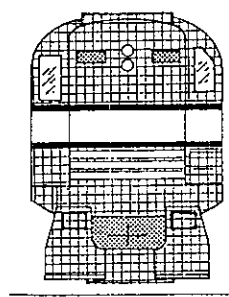

RED

LOW LETTERS BOTH ENDS

BLACK

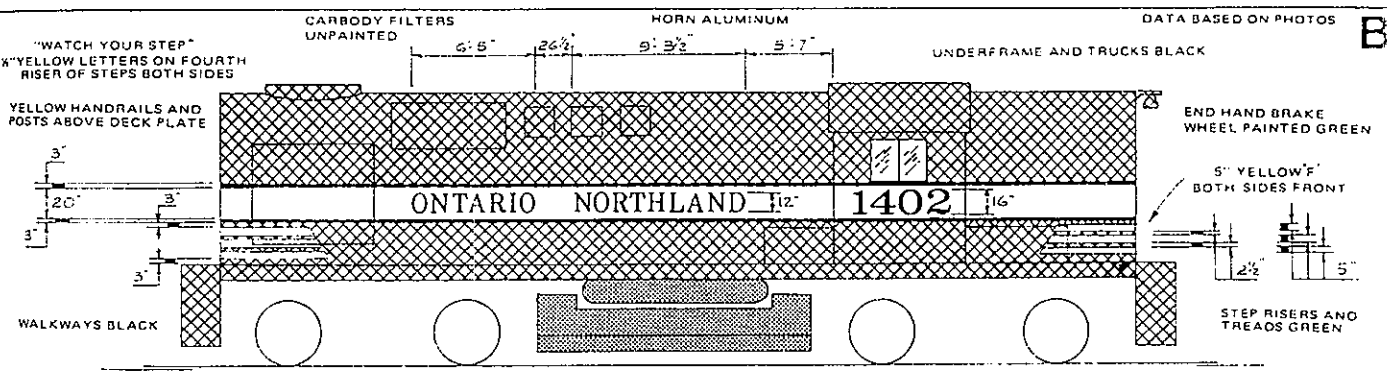

O.N.R., 1400 CLASS
MLW., RS-10, 1600 hp., B-B

Experimental paint scheme which used light green in place of dark green, all other color data was the same as the units shown in Drg. A above.

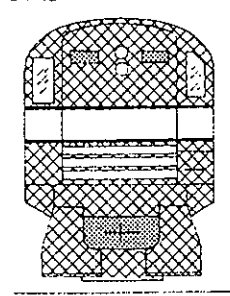
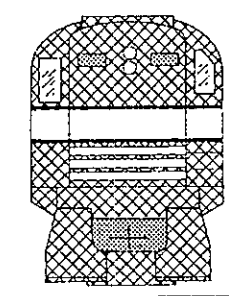

BLACK

LPD

10-14-76

Revision

RAIL CANADA vol. II

PAINTING AND LETTERING GUIDE FOR CANADIAN RAILWAYS

Subject - DIESEL LOCOMOTIVES
Section - OUTLINE DRAWINGS
Railway - ONTARIO NORTHLAND

Date 5-10-76 By D.C. Drg. No. D-37

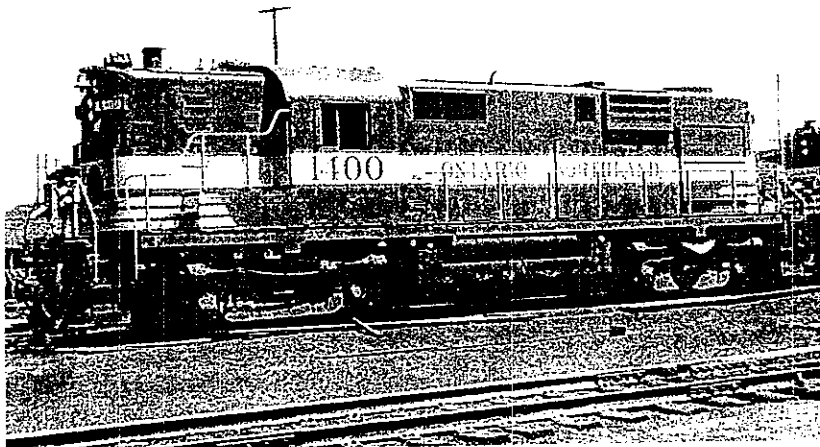

1400 First of the RS-10's delivered and equipped with bell, horns, and steam generator on/in short hood (front). Unlike the GP7's & 9's which have standard carbody air intakes, hardly two RS10 & 18 locomotives are the same.

ALL PHOTOS KEN WILSON COLLECTION

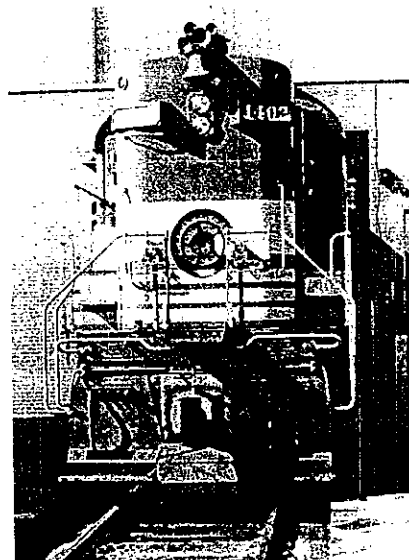

1402 Two good, almost square on photos of this RS-10 are just the type of picture a modeller appreciates when doing a decal job. When ever possible it is this type of photo we look for.

LPD

RAIL CANADA vol. II

PAINTING AND LETTERING GUIDE
FOR CANADIAN RAILWAYS

Subject - DIESEL LOCOMOTIVES

Section - PROTOTYPE PHOTOS

Railway - ONTARIO NORTHLAND

Date: 4-28-77

By: D.C.L.

Drq. No. P227

LPD

Revision

REMAINING SURFACES INCLUDING POSTS

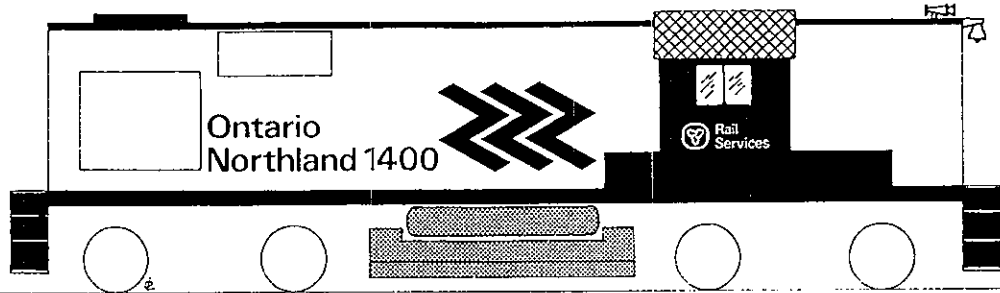

STEP EDGES YELLOW

O.N.R., 1400 CLASS

MLW., RS-10, 1600 hp., B-B

At this writing it is not known if any Ontario Northland RS-10's will be painted in this scheme but the drawing was prepared using the data on hand.

The small Northland chevrons are located on each end of locomotive except where grabirons interfered.

Rail Services and Trillium are painted White on cab side.

DK. BLUE

LT. BLUE

YELLOW

BLACK

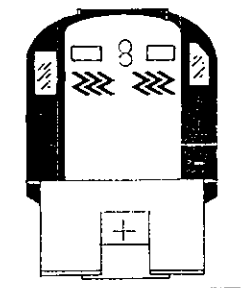

REAR

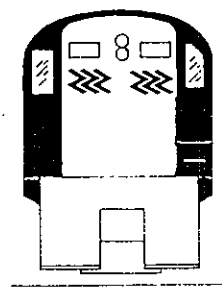

FRONT

YELLOW HANDRAILS AND POSTS ABOVE DECK PLATE

WALKWAY TREAD SURFACES BLACK

DATA FROM RAILWAY DHGS BY GREG KENNELLY

B

HORN ALUMINUM

GRABIRONS YELLOW

HANDBRAKE WHEEL GREEN

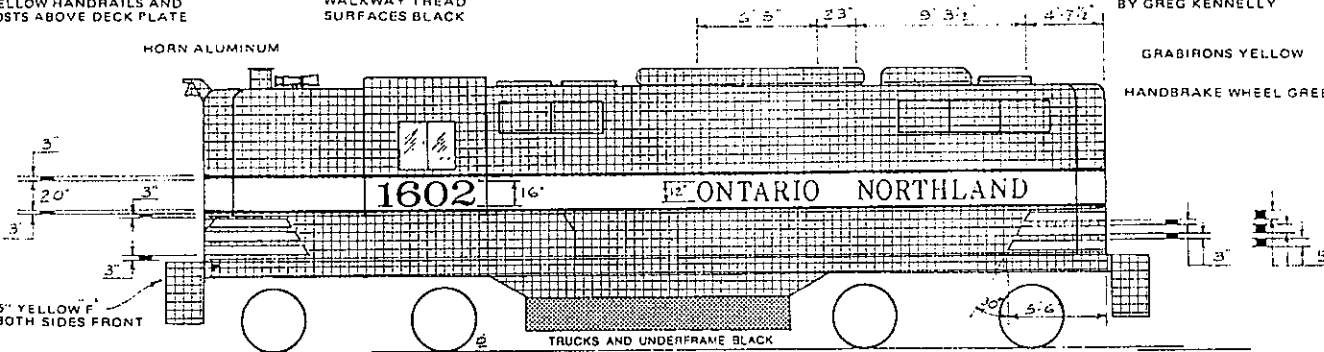

O.N.R., 1600 CLASS

GMDL., GP9, 1750 hp., B-B

The GP9 paint work is very similar to that applied to the RS-10 the same basic design parameters where used.

The stove pipe exhaust from ALCO MLW steam generators is seen on the roof of the short hood units were removed from RS-2/3 engines.

An ALCO GP18 is the easiest locomotive to modify for the average maker. Nose bell and other details are available from the "Juneco" line of inset detail parts.

Athearn PFM, Hallmark all made units that with a bit of work will do justice to an ONR model.

WHEEL RIM FACES WHITE WHEN NEW

BLACK

GREEN

YELLOW

RED

DO NOT GET ON FOOTBOARD WHEN ENGINE IS APPROACHING

1" YELLOW LETTERS FRONT AND BACK

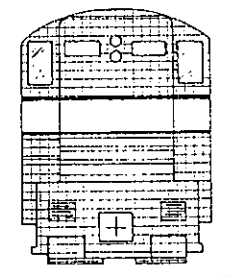

FRONT

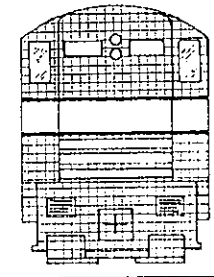

REAR

LPD

RAIL CANADA vol. II

PAINTING AND LETTERING GUIDE FOR CANADIAN RAILWAYS

Subject -- DIESEL LOCOMOTIVES

Section -- OUTLINE DRAWINGS

Railway -- ONTARIO NORTHLAND

Date: 11/22/76

By: D.C.L.

Dir: N.D. 38

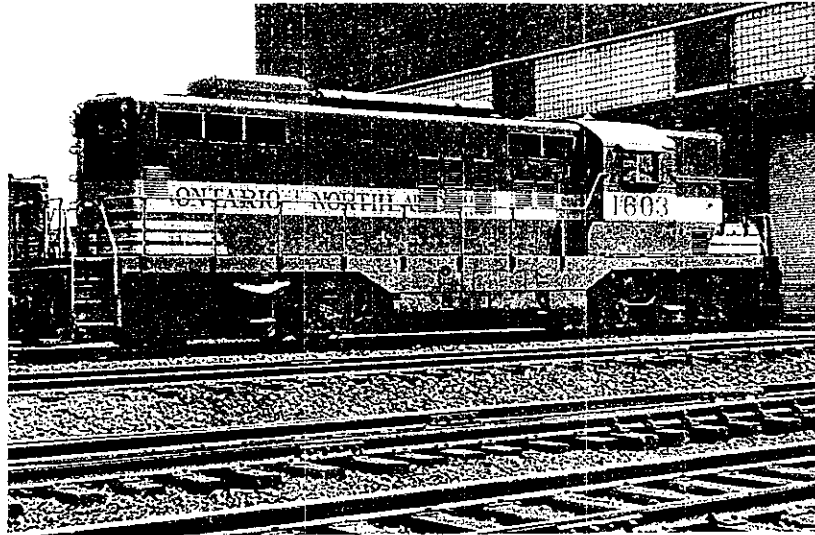

KEN WILSON COLLECTION

Right side above and left side below show most of the features of the GP9 in this paint scheme. Note enlarged fuel tank, air tanks located on roof and raised winterization hood. 1604 taken at North Bay, August 17, 1974.

The A.H.M. GP-18 is the most likely starting place for a model of these units

PIERRE PATENAUGE

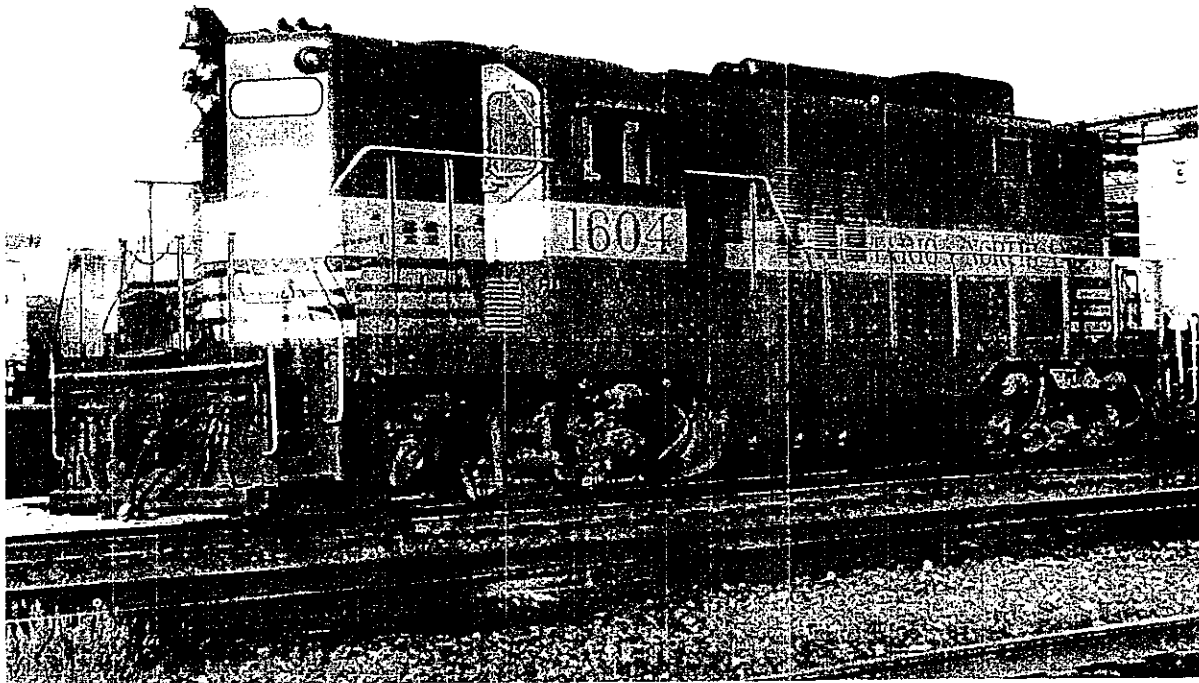

STEP HAND
REMAINDER
INCLUDING I

STEP EDGE

O.N.R., 160
GMDL., GP

Very sim
land chev

The pilot

"WATCH
3" YELLOW L
RISER OF

4" YELLOW
BOTH SIDES

STEP EDGES

O.N.R., 170
DD, SD40-

Heaviest r
Yellow pa

No model
ed model
motor an
and work.

LPD

RAIL CANADA vol. II

PAINTING AND LETTERING GUIDE FOR CANADIAN RAILWAYS

Subject - DIESEL LOCOMOTIVES
Section - PROTOTYPE PHOTOS
Railway - ONTARIO NORTHLAND

Date: 4-26-77 | By: D.C.L. | Drg. No. PP-217

LPD

Revision:

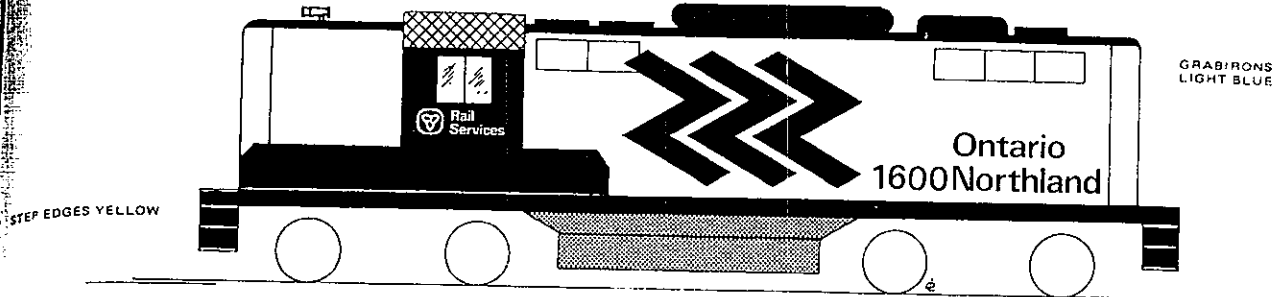

STEP EDGES YELLOW

GRABIRONS LIGHT BLUE

O.N.R., 1600 CLASS
 GMDL., GP9, 1750 hp., B-B

DK. BLUE LT. BLUE YELLOW BLACK

Very similar to the RS-10 paint scheme but with the larger Northland chevrons on the sides.
 The pilots will most likely be painted dark blue.

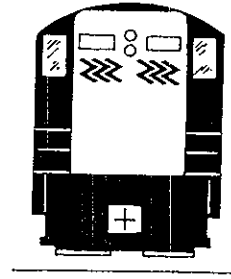

FRONT

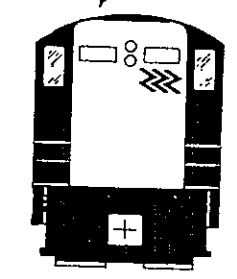

REAR

"WATCH YOUR STEP"
 1/2" YELLOW LETTERS ON FOURTH RISER OF STEPS BOTH SIDES

DATA FROM RAILWAY DRGS BY GREG KENNELLY

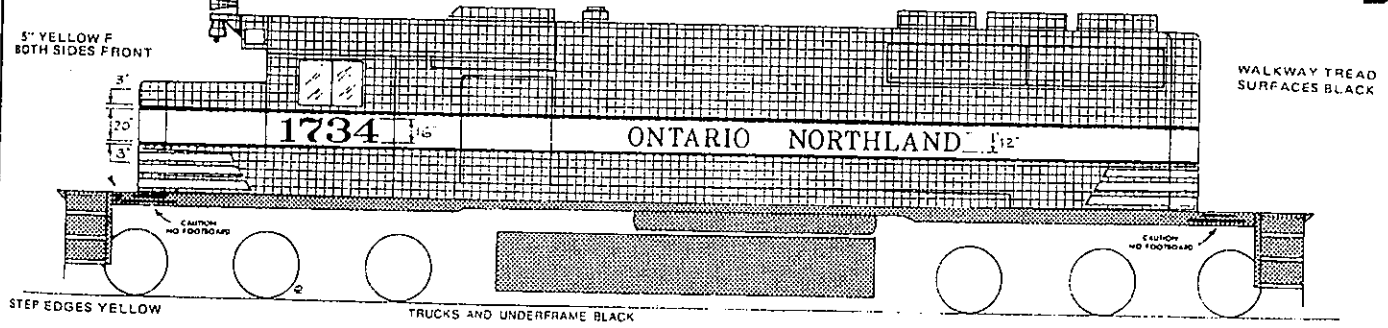

5" YELLOW F BOTH SIDES FRONT

WALKWAY TREAD SURFACES BLACK

STEP EDGES YELLOW

TRUCKS AND UNDERFRAME BLACK

O.N.R., 1700 CLASS
 DD, SD40-2, 3000 hp., C-C

BLACK GREEN YELLOW RED

Heaviest motive power on the ONR and last to receive the green and Yellow paint scheme.

No model exists to date in any scale for the SD40 but an experienced modeler can cross kit Athearn's SD45 running gear with a new motor and an Atlas or Life Like carbody with a bit of ingenuity and work.

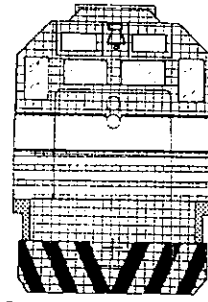

FRONT

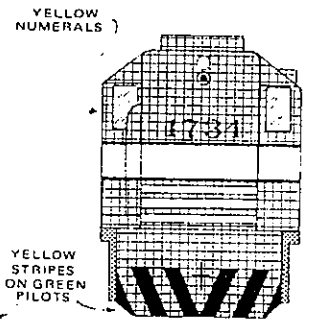

REAR

YELLOW NUMERALS

YELLOW STRIPES ON GREEN PILOTS

LPD

RAIL CANADA vol. II

PAINTING AND LETTERING GUIDE FOR CANADIAN RAILWAYS

Subject - DIESEL LOCOMOTIVES
 Section - OUTLINE DRAWINGS
 Railway - ONTARIO NORTHLAND

Date 11-13-76 By D.C.L. Dwg No D 39