

INSTALLATION INSTRUCTIONS

ATRO PARTS

ENGINEERED | DURABLE | RELIABLE
MANUFACTURED IN ST. CLAIR, MISSOURI | U.S.A.

PT50-59736 INSTALLATION TOOL

FOR USE WITH PB50-36321 & PB50-36322 PIVOT BUSHINGS

Popular on Hendrickson Intraax/Vantraax Suspensions

1. Lubricate ACME threaded bolt and thrust bearing with synthetic grease before each use
2. ACME bolt requires a 1 5/8" socket
3. Use of high torque drill is recommended over impact gun
4. Set screws are to be used as alignment pins for the installation and/or removal of the OEM rubber pivot bushings
5. Be sure liner is placed in the ID of the pivot bushing to insure the bushing remains square throughout the installation

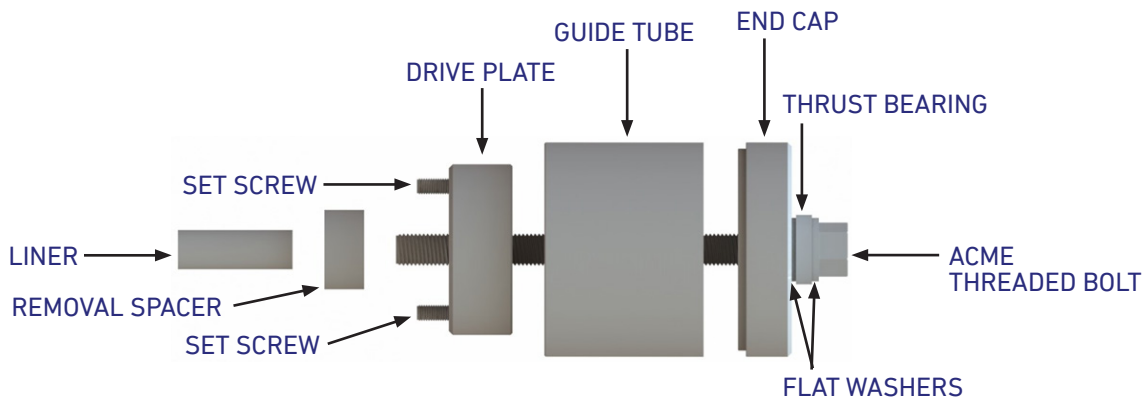

KIT CONTAINS:

- (1) ACME Threaded Bolt
- (1) Thrust Bearing
- (2) Flat Washers
- (2) Set Screws
- (1) End Cap
- (1) Guide Tube
- (1) Drive Plate
- (1) Removal Spacer
- (1) Liner

CELEBRATING 30 YEARS
ATRO
POLYURETHANE • SOLUTIONS

POLYURETHANE PARTS | SOLUTIONS FOR HEAVY TRUCKS

ATROBUSHING.COM
©2017 ATRO ENGINEERED SYSTEMS, INC.

6 Bolte Lane
St. Clair, Missouri 63077 | U.S.A.
(800) 325.6114 | Fax (866) 920.2005

DC00-10022

ATROBUSHING.COM | 1.800.325.6114

ATRO Engineered Systems, Inc. is not liable for any errors herein. All manufacturers' names and part numbers are used without permission; no endorsement, affiliation, or recommendation is implied. They are included for reference purposes only.