

REVISIONS					
LTR	ECO	DESCRIPTION	DATE	APPROVED	ZONE
A		INITIAL_RELEASE	1/18/2016	RWW	
B		REV_TITLE_BLOCK_ADD_UNROLL_DIRECTION	3/28/2016	RWW	

NOTES:
XXXXX

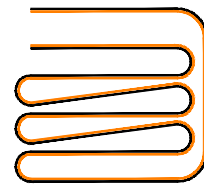
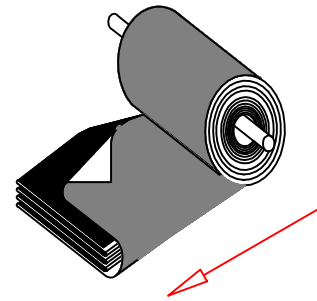

PIECE 1

THESE INSTRUCTIONS
ARE FOR UNROLLING FROM
THE BOTTOM OF THE ROLL

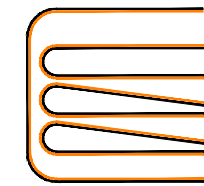
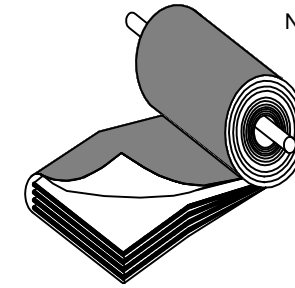

PIECE 2

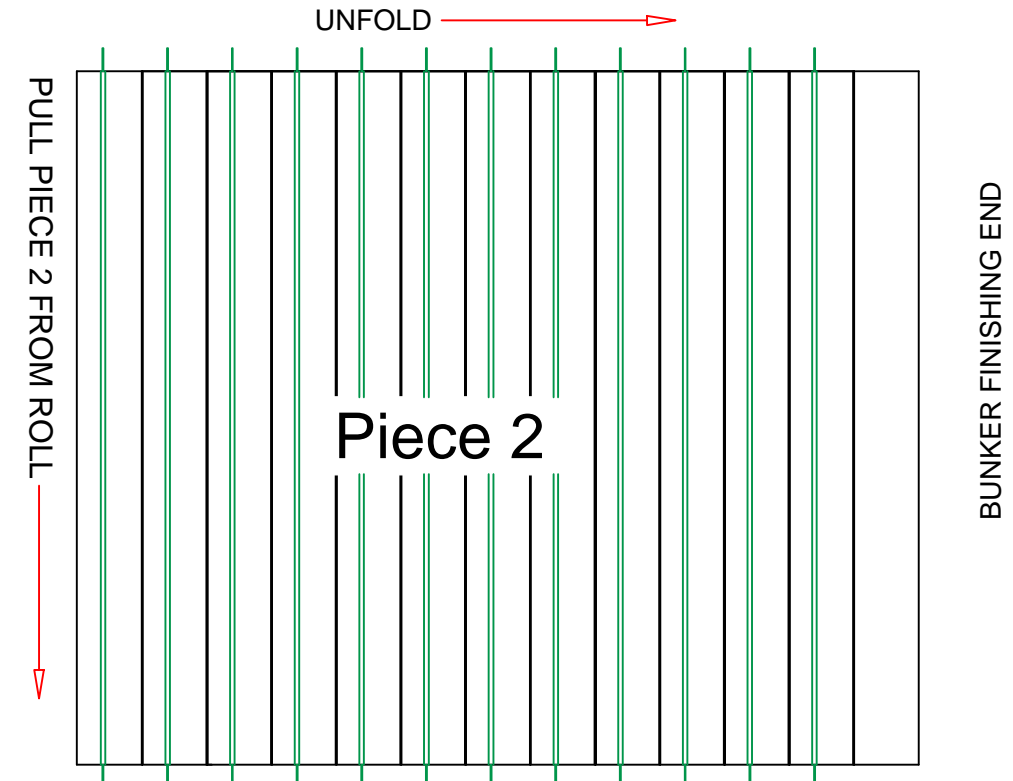
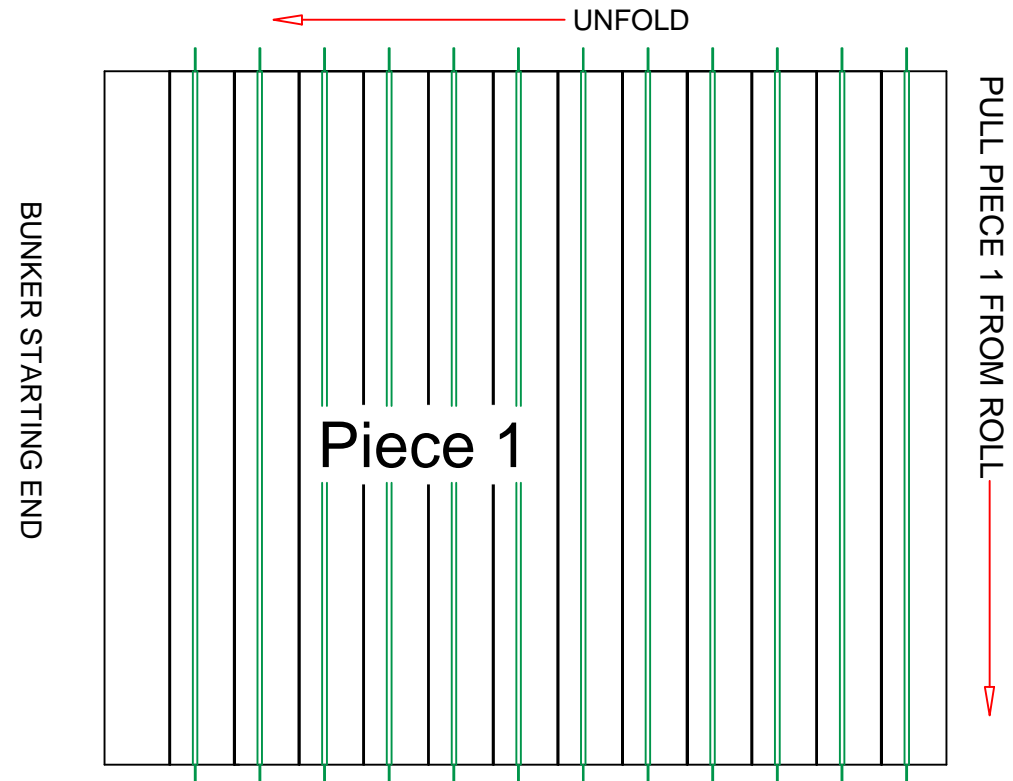

DEPLOYMENT INSTRUCTIONS:

1. PULL PIECE 1 & 2 ACROSS THE GRAIN PILE ABOUT 1/2 OF THE WAY FROM THE STARTING END
 2. JOIN TOP LAYER OF PIECE 1 TO TOP PANEL OF PIECE 2 AS SHOWN ON GENERAL SEWING INSTRUCTIONS PAGE 2 AND 3
 3. WHILE HOLDING PIECE 2 PULL PIECE 1 TO THE STARTING END OF THE BUNKER
 4. UNFOLD PIECE 2 TO THE FINISHING END OF THE BUNKER
- FOR FURTHER INSTRUCTIONS VISIT ravenefd.com/installation

		COVER TYPE		
		OVAL 2 PIECE with Straps Flip Folded		
RAVEN ENGINEERED FILMS PO BOX 5107 SIOUX FALLS, SD 57117-5107 +1 (800) 635-3456		SALES ORDER	DRAWING NUMBER	REV
DRAWN RWW	NAME DATE 1/15/2016	1	O2STFS	B
DO NOT SCALE DRAWING		PROPRIETARY AND CONFIDENTIAL INFORMATION OF RAVEN INDUSTRIES INC. THIS DRAWING AND THE INFORMATION HEREON ARE RAVEN INDUSTRIES INC. PROPERTY AND MAY BE USED BY OTHERS ONLY AS AUTHORIZED IN WRITING BY RAVEN INDUSTRIES INC. - ALL RIGHTS RESERVED UNDER THE COPYRIGHT LAWS.		

REVISIONS					
LTR	ECO	DESCRIPTION	DATE	APPROVED	ZONE
A		INITIAL_RELEASE	1/18/2016	RWW	
B		REV_TITLE_BLOCK	3/28/2016	RWW	

NOTES:
XXXXX

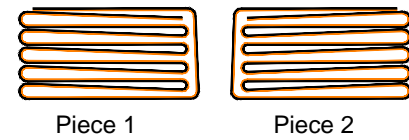

FIGURE 1

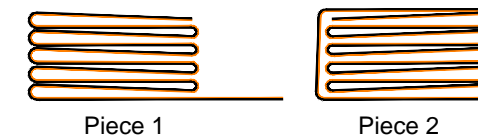

FIGURE 2

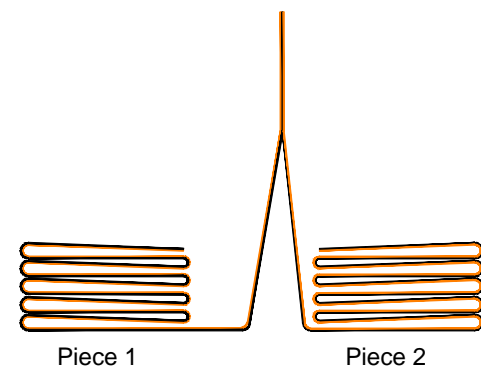

FIGURE 3

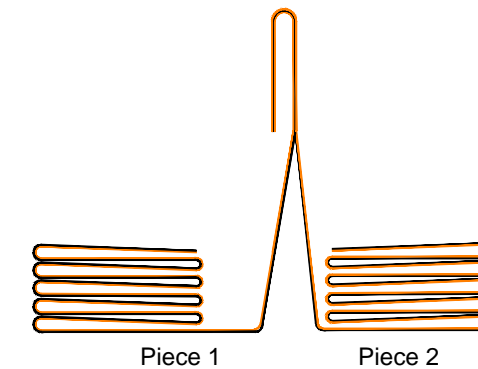



FIGURE 4

SEWING INSTRUCTIONS

1. ONCE FIRST AND SECOND PANEL ARE UNROLLED, FLIP THE TOP FOLD OF PIECE1 TOWARDS THE BUNKER FINISHING END, (FIGURE 2)
 2. LIFT UP THE NEXT PANEL OF PIECE 1 AND THE TOP PANEL OF PIECE 2 HOLDING THE PANELS TOGETHER BLACK TO BLACK, (FIGURE 3)
 3. SEW ACROSS THE ENTIRE SEAM AS SHOWN IN THE GENERAL SEWING INSTRUCTIONS, (PAGE 3)
 4. FOLD OVER EXISTING SEWN SEAM AND SEW A SECOND PASS AS SHOWN ON THE GENERAL SEWING INSTRUCTIONS, (FIGURE 4)
- FOR FURTHER INSTRUCTIONS VISIT raveneff.com/installation

 RAVEN ENGINEERED FILMS PO BOX 5107 SIOUX FALLS, SD 57117-5107 +1 (800) 635-3456	COVER TYPE		
	OVAL 2 PIECE with Straps Flip Folded Page 2 of 3		
NAME: RWW DATE: 1/18/2016	SALES ORDER: 1	DRAWING NUMBER: O2STFS	REV: B
PROPRIETARY AND CONFIDENTIAL INFORMATION OF RAVEN INDUSTRIES INC. THIS DRAWING AND THE INFORMATION HEREON ARE RAVEN INDUSTRIES INC. PROPERTY AND MAY BE USED BY OTHERS ONLY AS AUTHORIZED IN WRITING BY RAVEN INDUSTRIES INC. - ALL RIGHTS RESERVED UNDER THE COPYRIGHT LAWS.			

8

7

6

5

4

3

2

1

REVISIONS					
LTR	ECO	DESCRIPTION	DATE	APPROVED	ZONE
A		INITIAL_RELEASE	1/18/2016	RWW	
B		REV_TITLE_BLOCK	3/28/2016	RWW	

NOTES:

XXXXX

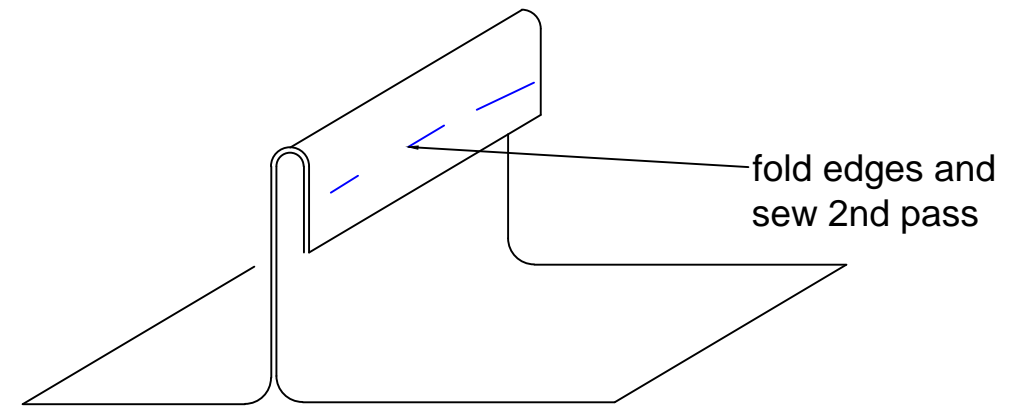
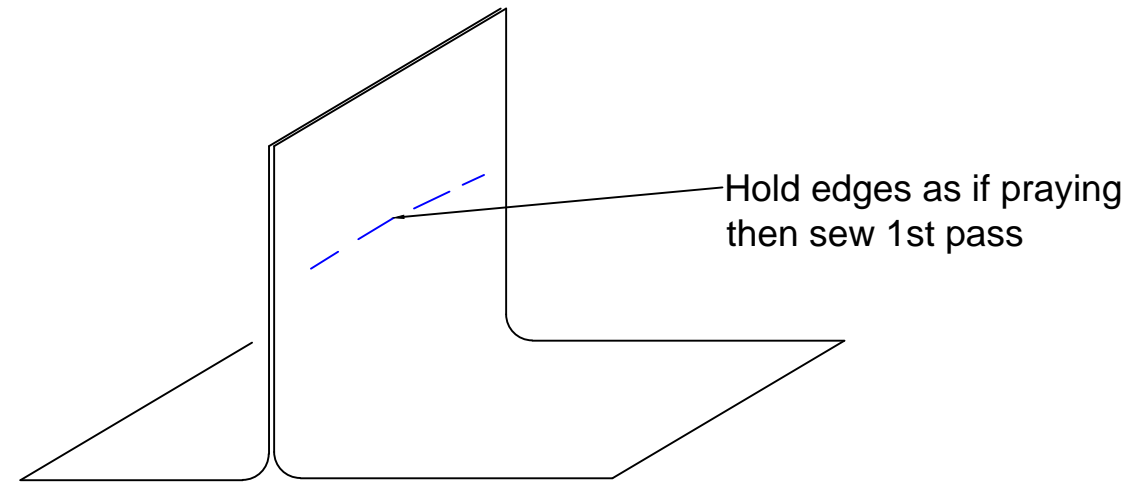

GENERAL SEWING INSTRUCTIONS

1. WHEN SEWING MAKE ABOUT A 15 FOOT PASS THEN PULL OUT AND RESTART SEWING ABOUT 3" BEHIND WHERE YOU PULLED OUT. THIS WILL LIMIT THE AMOUNT OF SEWING THAT CAN COME LOOSE FROM A POOR SEAM. DO THIS OVER THE ENTIRE LENGTH TO BE SEWN.
2. FOLD THE SEAM OVER AND REPEAT STEP 1 ACROSS THE ENTIRE LENGTH OF THE SEAM.

 RAVEN ENGINEERED FILMS PO BOX 5107 SIOUX FALLS, SD 57117-5107 +1 (800) 635-3456		COVER TYPE			
		GENERAL SEWING INSTRUCTIONS Page 3 of 3			
NAME	DATE	SIZE	SALES ORDER	DRAWING NUMBER	REV
DRAWN RWW	1/18/2016	B	'	PAGE_3_OF_3	B
DO NOT SCALE DRAWING		PROPRIETARY AND CONFIDENTIAL INFORMATION OF RAVEN INDUSTRIES INC. THIS DRAWING AND THE INFORMATION HEREON ARE RAVEN INDUSTRIES INC. PROPERTY AND MAY BE USED BY OTHERS ONLY AS AUTHORIZED IN WRITING BY RAVEN INDUSTRIES INC. - ALL RIGHTS RESERVED UNDER THE COPYRIGHT LAWS.			

8

7

6

5

4

3

2

1