



ASSEMBLY INSTRUCTION



PLT LEG - U - 48NB / 60NB 41H

PART LIST

1		Wood Screw x 20 mm	16 pcs
2		Sticker	8 pcs

MAIN DESK BEAM

PART LIST

3		Wood Screw x 20 mm	15 pcs
4		Bolts M6 X 12	10 pcs

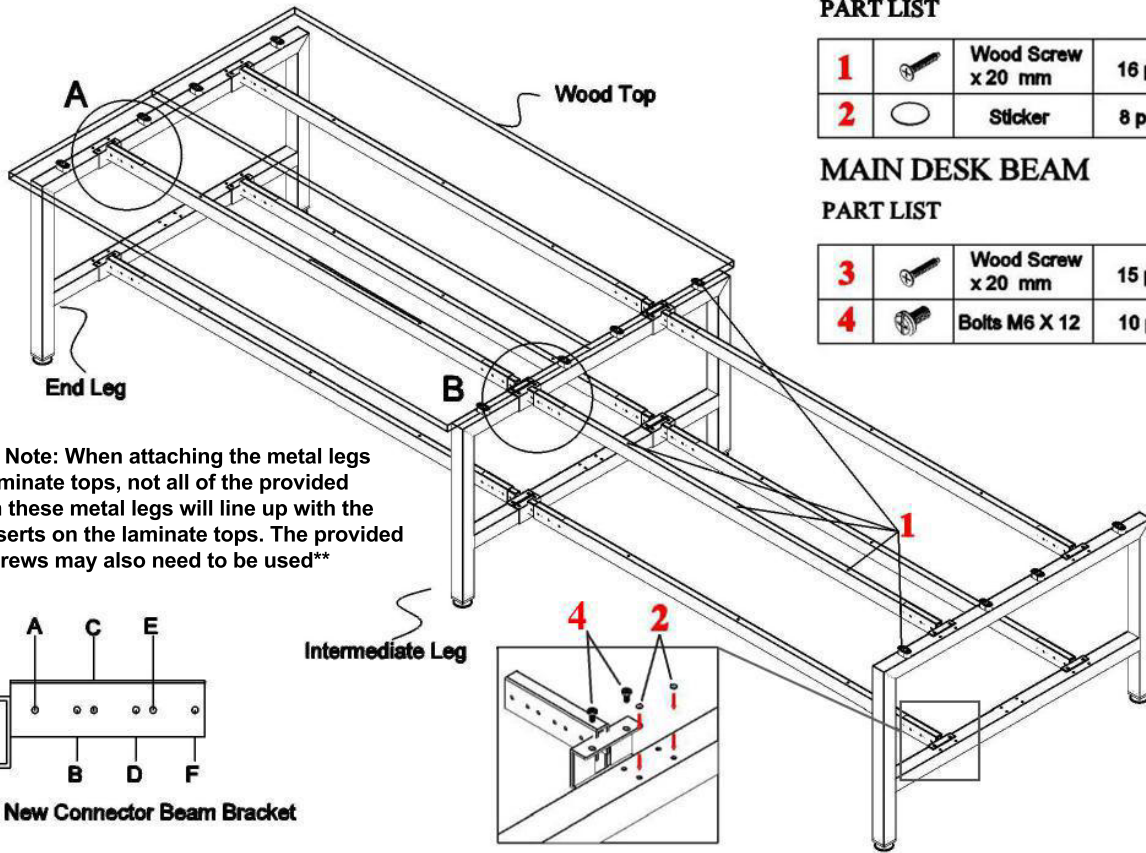

****Please Note:** When attaching the metal legs to the laminate tops, not all of the provided holes on these metal legs will line up with the metal inserts on the laminate tops. The provided wood screws may also need to be used**

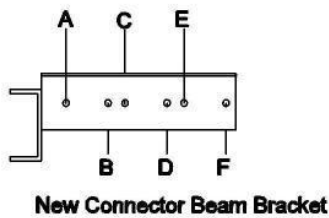

A. USE PART LIST ITEM 2

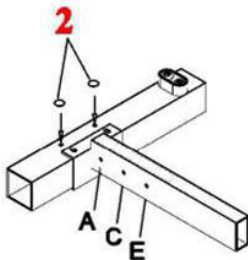

END LEG CONNECTION

- Please use A, C and E hole.
- Stick in the end leg screw hole.

Performance Work Surfaces are used in many applications. Preinstalled existing metal inserts in the top are not required for element series, 20mm wood screws are provided.

***TWO PEOPLE ARE REQUIRED FOR ASSEMBLY**

DESK

1. Use M6 X 12MM bolts (part 4) to attach the CBBs to the upper and lower cross beams of the u-leg as shown in the diagram above.
3. Slide the main desk beam over the CBBs.
4. Attach beams to CBBs using bolts M6 x 12MM (part 4).
5. Place the table top on top of the leg assembly and use wood screw (part 1) to secure u-legs to the table top.

NOTE: The wood screw pack is inside the beam.

B.

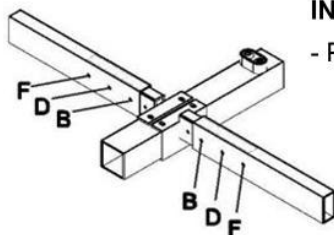

INTERMEDIATE LEG CONNECTION

- Please use B, D and F hole.

- DO not tighten any screw or bolt until the unit is completely assembled.
- Ensure all bolts and screws are tightened before using the product, check bolts and screws every 6 months.
- If any parts are missing, broken, damaged or worn, stop use of product until repairs have been made using factory authorized parts.
- Failure to follow these warnings may result in injury.