

**PART LIST**

KEY QTY	DESCRIPTION	KEY QTY	DESCRIPTION	KEY QTY	DESCRIPTION	
1	5	Caster	6	1	Seat	
2	1	Base	7	1	Backrest	
3	1	Seat Post	8	2	Armrest	
4	1	Seat Post Cover	9	6	Armrest Screw	
5	1	Mechanism	10	1	Back Tube Cover	
				11	3	Mechanism Bracket Screw + Washer
				12	4	Mechanism Screw
				13	1	M5 Size Allen Wrench

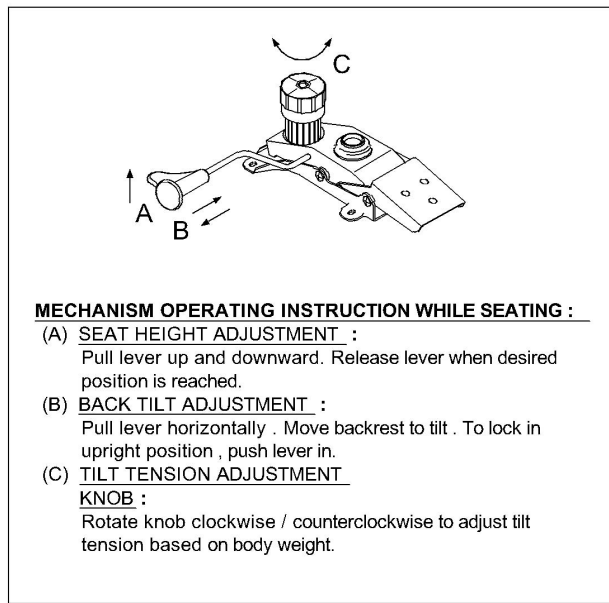
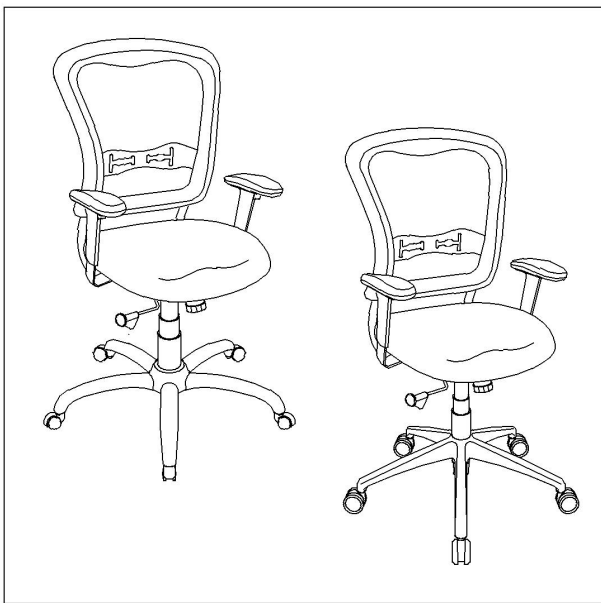
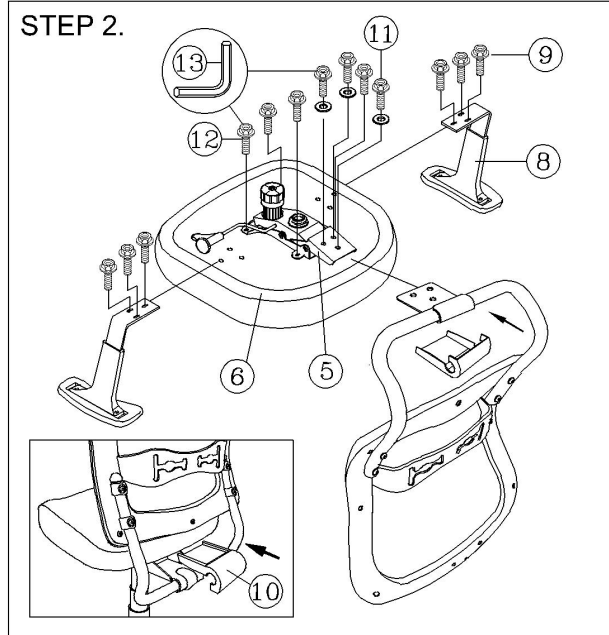
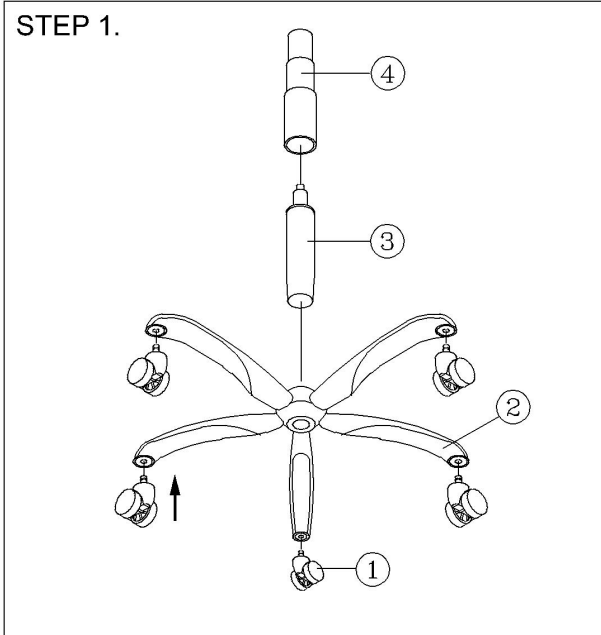

**PREVENTIVE MAINTENANCE AND WARNING!**

- USE THIS PRODUCT ONLY FOR SEATING ONE PERSON AT A TIME.
- DO NOT USE THIS CHAIR AS A STEP STOOL / LADDER.
- DO NOT SIT ON ANY PART OF THE CHAIR EXCEPT THE SEAT.
- DO NOT USE CHAIR ON UNEVEN FLOOR SURFACES.
- DO NOT USE CHAIR UNLESS ALL BOLTS, SCREWS AND KNOBS ARE TIGHTENED.
- EVERY SIX MONTHS, PLEASE MAKE SURE ALL BOLTS, SCREWS AND KNOBS ARE FULLY TIGHTENED TO ENSURE STABILITY.
- IF ANY PARTS ARE MISSING, BROKEN, DAMAGED OR WORN, STOP USE OF THE PRODUCT UNTIL REPAIRS ARE MADE USING FACTORY AUTHORIZED PARTS.
- DISPOSE OF PACKAGING PROPERLY. PLASTIC BAG IS NOT A TOY. DO NOT USE PLASTIC BAG AS HEAD COVERING - IT MAY CAUSE SUFFOCATION.
- FAILURE TO FOLLOW THESE WARNINGS COULD RESULT IN SERIOUS INJURY.
- NOTE: SOME SCREWS MAY BE PREASSEMBLED. IF PREASSEMBLED, IGNORE ASSEMBLY INSTRUCTIONS.