















BEFORE ASSEMBLY, PLEASE REMOVE ALL PARTS FROM THE CARTON AND VERIFY THAT YOU HAVE CORRECT QUANTITIES.

<b>A</b>		L	1	<b>G</b>		M6x16mm	2
<b>B</b>		R	1	<b>G1</b>		M6x30mm	4
<b>C</b>			1	<b>G2</b>		M6x35mm	6
<b>D</b>			1	<b>H</b>			4
<b>E</b>			1	<b>I</b>			4
<b>F</b>			2	<b>J</b>		5#	1

<p><b>1</b></p>  <p>Start screws, do not tighten Commencez à visser, ne pas serrer Inicie los tornillos, no apriete</p>	<p><b>2</b></p>  <p>Start screws, do not tighten Commencez à visser, ne pas serrer Inicie los tornillos, no apriete</p>	<p><b>3</b></p>  <p>Set chair level on floor &amp; tighten screws. If chair wobbles, loosen screws, re-level chair, then re-tighten screws.</p> <p>Coloque la silla sobre el suelo, nivel y apriete los tornillos. Si la silla se tambalea, afloje los tornillos, volver a nivelar la silla, luego vuelva a apretar los tornillos.</p> <p>Définir le niveau de la chaise sur le sol et serrer les vis. Si le Président vacille, desserrer la vis, remettre à niveau le fauteuil, puis resserrer les vis.</p>
<p><b>4</b></p> 	<p><b>5</b></p>  <p>Start all two screws, then tighten Démarrer tous les quatre vis, puis serrer Iniciar los cuatro tornillos, luego apriete</p>	<p><b>6</b></p> 

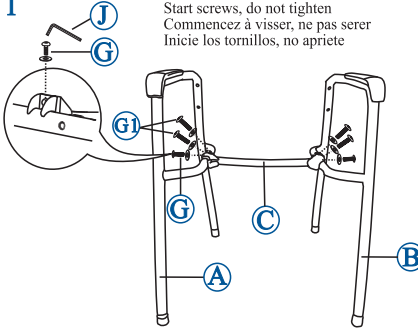
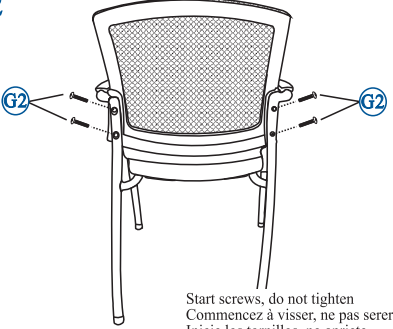
### PREVENTIVE MAINTENANCE AND WARNING

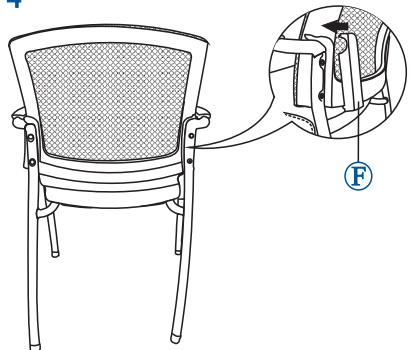
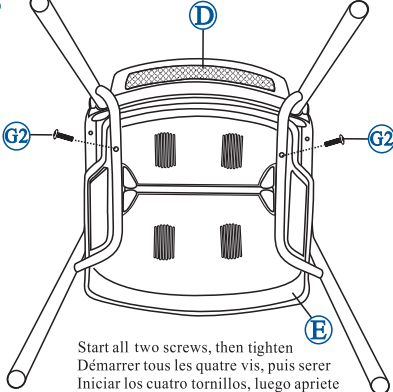
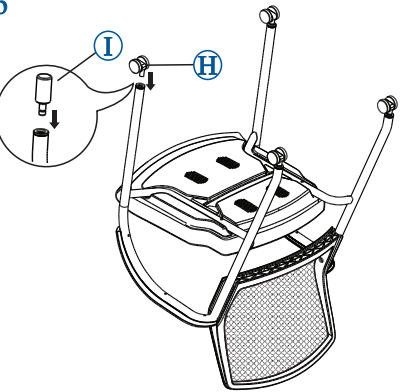
- USE THIS PRODUCT ONLY FOR SEATING ONE PERSON AT A TIME
- DO NOT USE CHAIR AS STEP STOOL/LADDER.
- DO NOT USE CHAIR UNLESS ALL BOLTS, SCREWS ARE TIGHTENED. AT LEAST EVERY THREE MONTHS, CHECK ALL BOLTS, SCREWS TO BE SURE THEY ARE TIGHTENED.
- IF ANY PARTS ARE MISSING, BROKEN, DAMAGED OR WORN, STOP USE OF THE PRODUCT UNTIL REPAIRS ARE MADE USING FACTORY AUTHORIZED PARTS.
- FAILURE TO FOLLOW THESE WARNINGS CAN RESULT IN SERIOUS INJURY.