

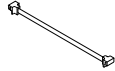

36" W Lateral File BF drawers P.1



<p>1</p>  <p>Keys 2 Pcs</p>	<p>2</p>  <p>Legal Hanger Bar 2 Pcs</p>	<p>3</p>  <p>Screw M6*15 11 Pcs</p>	<p>4</p>  <p>M4 Allen Wrench 1 Pc</p>	<p>A</p>  <p>Lateral File 1 Pc</p>	<p>B</p>  <p>Metal Leg 2 Pcs</p>
------------------------------------------------------------------------------------------------------------------	------------------------------------------------------------------------------------------------------------------------------	--------------------------------------------------------------------------------------------------------------------------	----------------------------------------------------------------------------------------------------------------------------	---------------------------------------------------------------------------------------------------------------------------	-------------------------------------------------------------------------------------------------------------------------

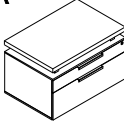
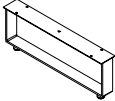
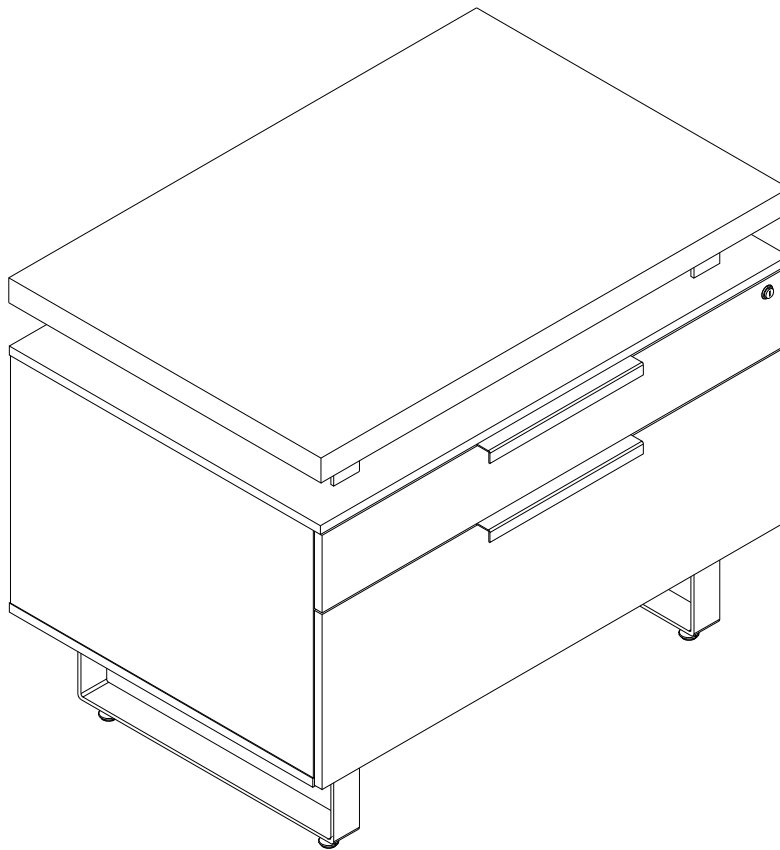

IMPORTANT NOTE:

Place all wooden parts on a clean and smooth surface such as a rug or carpet to avoid the parts from being scratched
 Check that you have all parts and hardware.
 Remove all wrapping materials, including staples & packing straps before you start assemble.
 Do not tighten all screws or bolts until all completely assembled.
 Keep all hardware parts out of reach of children.

36" W Lateral File BF drawers P.2

1 Use screws (3) to attach the metal leg (B) under the Lateral file (A).

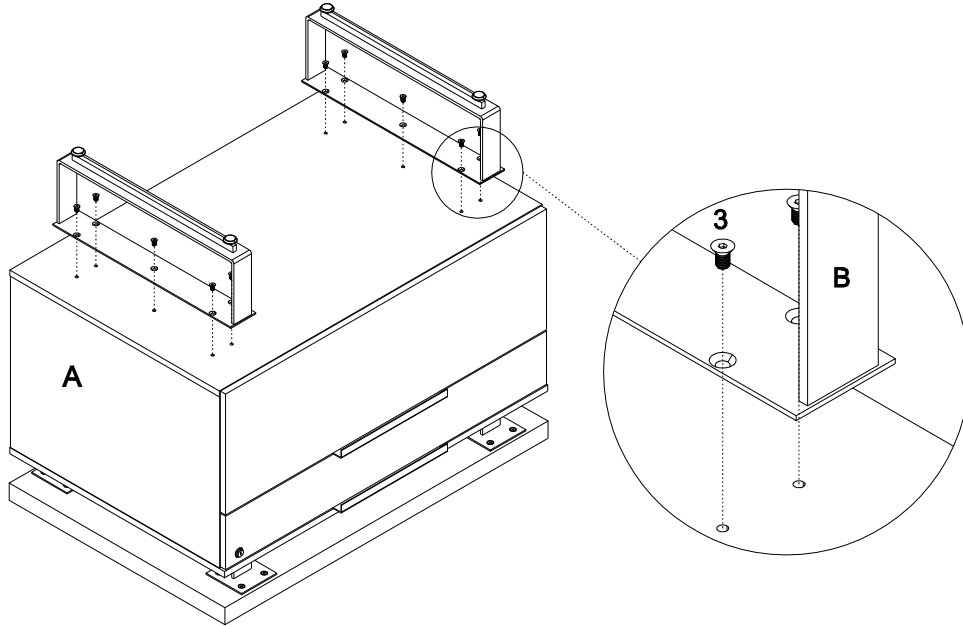

2

No filing bars required for Letter sized hanging folders.

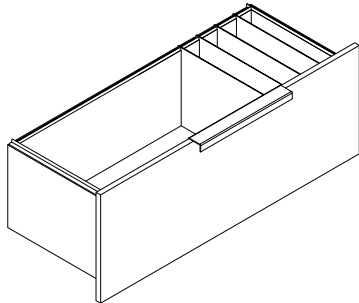

One filing bar for combination of Letter and Legal sized hanging folders.

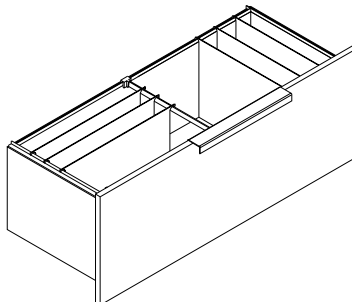

Two filing bars for Legal sized hanging folders.

