

Thank you for purchasing the Performance Laminate Door Set.
Please follow these instructions for easy assembly.

PURCHASE SEPARATELY

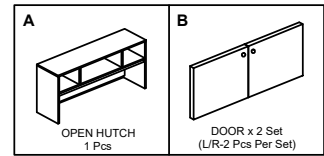
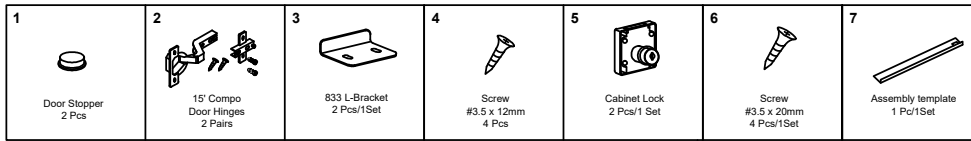

OPTION 2

1

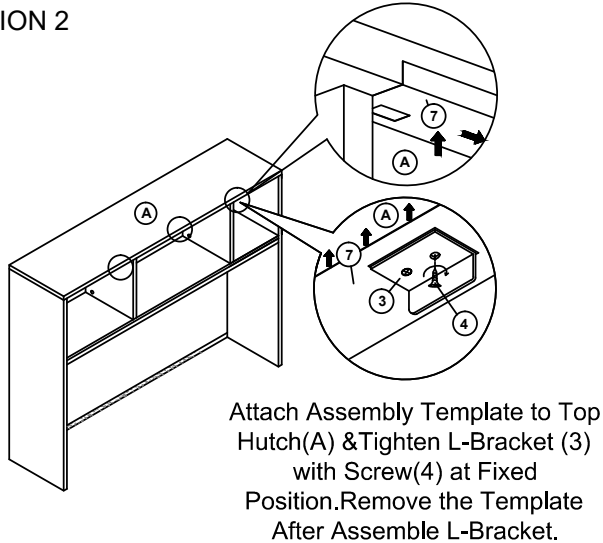

2

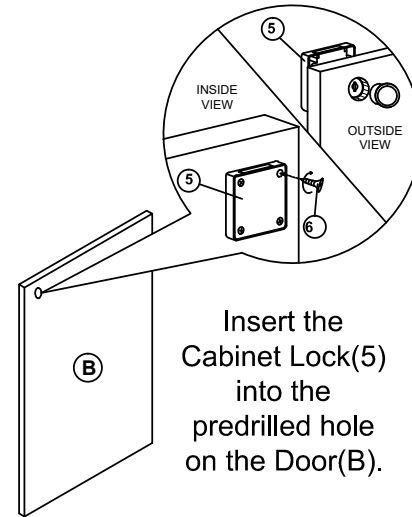

3

Attach the Doors Panel (B) x 2 SETS to the Center Vertical Panel and Side Panel of OPEN HUTCH (A) with Hinges (2).

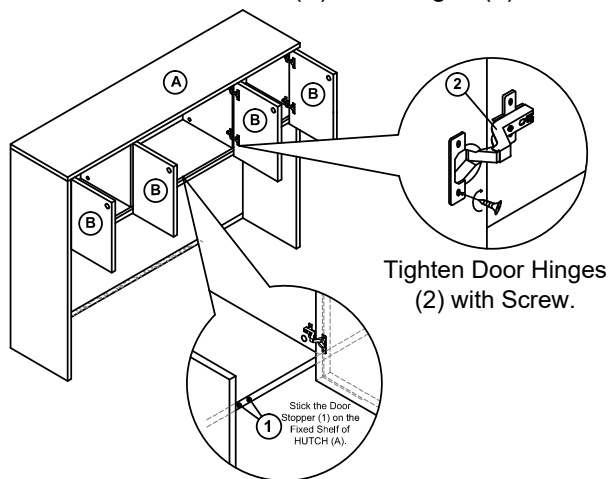

4

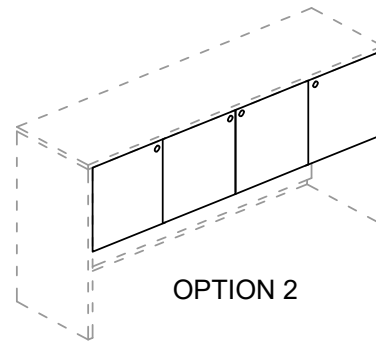

IMPORTANT !!

- Place all wooden parts on a clean and smooth surface such as a rug or carpet to avoid the parts from being scratched.
- Check that you have all parts and hardware.
- Remove all wrapping materials, including staples & packing straps before you start to assemble.
- Do not tighten any screws or bolts until the unit is completely assembled.
- Keep all hardware parts out of reach of children.